

TOSHIBA

Installation Instruction
ELECTRIC WATER HEATER
For Home Use Only

Model

TWH-45WTH(W)

TWH-38WTH(W)

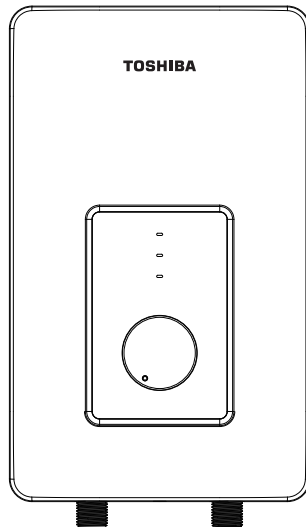

Read this manual carefully before installation and use

After-sales engineers should test the ground resistance for the customers at least once per year to insure the grounding of the water heater is reliable

Sincerely thank you for selecting our electric water heater. Please read this manual carefully before use; correctly grasp the methods for installation and use of this electrical water heater, to make full use of its excellent performances. Please do preserve the instruction manual for future reference.

TABLE OF CONTENTS

<u>TITLE</u>	<u>PAGE</u>
1.Cautions	(2)
2.Product introduction	(3)
3.Unit installation	(5)
4.Methods of using	(8)
5.Maintenance	(9)
6.Troubleshooting	(10)

1. CAUTIONS

To prevent personal injury, injury to others and property damage, the instructions below must be followed. Incorrect operation due to failure to follow instructions will cause harm or damage. Installation must be carried out by a qualified personnel and in compliance to the local authority regulations.

Special Cautions

- This water heater is for household, and it can be installed wherever place that need hot water, eg. Washing hands, dishes or foods, and so on. (Multi directional water supply is not available).
- Plug is not used for this water heater; this water heater must be connected directly with power switch that comes with leakage-protection. Please distinguish live line (red/brown), neutral line (blue) and earth line (green/yellow) during installation.
- Do check whether the amperes of the household wiring enough before installation, and dedicated circuit must be used when installation.
- Before installing this water heater, check and confirm the earth electrode on the socket is reliably earthed, without electricity.
- The water heater should be installed indoor, where temperature keeps over 0°C. If the water inside of water heater has been frozen, it's forbidden to turn on water heater before the ice meltdown.
- The hot water from the water heater may cause scald, please test the temperature of the hot water before use.
- The distance between water heater installed and water output should be as nearby as possible to avoid loss of heat.
- The electric water heater may be damaged if the water hardness is too high. To ensure longer product lifespan, please install and put it into use on condition that the local water hardness is less than 450mg/L (CaCO₃)
- In time of lightning/thunder, switch "Off" the Miniature Circuit Breaker (MCB) in advance to protect the water heater against possible damage.
- Inspection on the built-in ELCB (once a month) to avoid a hazard to users such as damage to property, serious injury or death.
- Do cut-off power supply before any maintenance. Any maintenance or adjustment towards this product by non-professional is highly prohibited.
- The damage power cord must be replaced by a good power cord provided by the manufacturer, and the replacement should be done by a qualified technician or engineer or professionals of the similar products.
- In order to avoid a hazard due to inadvertent resetting of the Earth Leakage Circuit Breaker (ELCB), this appliance must not be supplied through an external switching device, such as timer or connected to a circuit that is regularly switched "On" and "Off" by the utility.
- Water heater is equipped with adjustable flow capacity safety valve. For safety use, please do not change its installation location and do not block its water outlet.
- The shower head must be descaled regularly.
- When the shower is used by someone such as child, old person, sick person and physical handicapped person, the concern person is kindly requested to pay attention and check the shower temperature by using hand from time to time.
- The heater must be permanently connected to the electricity supply, direct from the consumer unit via a double poles linked switch with a minimum contact gap of 3mm in both poles. The switch must be readily accessible and clearly identifiable and out of reach of person using a fixed bath or shower. The wiring must be connected to the switch without the use of a plug or socket outlet.
- For any improper installation and incorrect operation of this product, our company will not be liable for any responsibility.



WARNING

The water heater should be earthed before use. Please ensure that the resistance of household earth wire is $<4\Omega$. Using water heater without earthed is highly prohibited.

2. PRODUCT INTRODUCTION

2.1 Technical Performance Parameters

Model	TWH-45WTH(W)	TWH-38WTH(W)	
Rated Voltage	220V~	220V~	
Rated Frequency	50Hz	50Hz	
Rated Power	4500W	3800W	
Rated Current	20.5A	17.3A	
Dia. Of Wire Code	2.5mm ²	2.0mm ²	
Air Switch	$\geq 25A$	$\geq 20A$	
Rated Pressure	0 MPa		
Minimum Flow Rate	1.2 Liters/minute		
Minimum Pressure	0.03 MPa		
Maximum Pressure	0.3 MPa		
Protection Class	I		
Water Proof Class	IP25		
Products Size	200×330×88 mm		
Knob Quantity	1		

2.2 Parts Identification

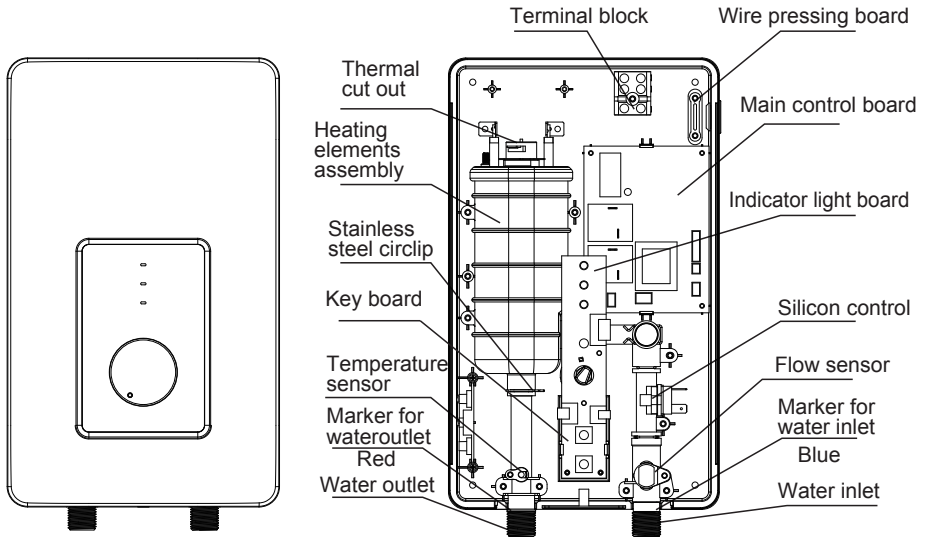

2.3 Internal Wire Diagram

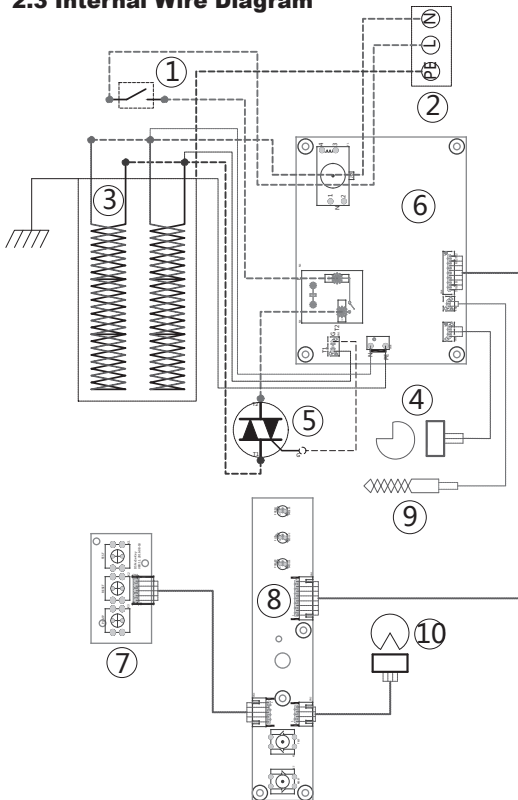

WIRING DIAGRAM

- ① : Thermal Cut Out
- ② : Terminal Block
- ③ : Heating Elements
- ④ : Flow Sensor
- ⑤ : Silicon Control
- ⑥ : Main Control Board
- ⑦ : Key board
- ⑧ : Indicator Light
- ⑨ : Temperature Sensor
- ⑩ : Knob potentiometer

3. UNIT INSTALLATION

3.1 Installation Instruction

- ① Check the capacity of power circuit;
- ② Power cord installation;
- ③ Water heater installation;
- ④ Plumbing connection;
- ⑤ Power supply connection;
- ⑥ Water Supply.

3.2 Power Cord Installation

Step 1

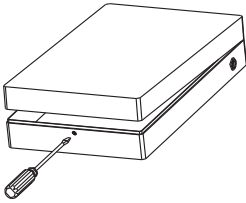

Remove the screws at the bottom of the unit. Lift up the Main Switch Knob and Power Knob to make it free. Remove the front plate gently.

Step 2

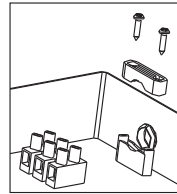

Remove the power cord wire pressing plate and keep the screws.

Step 3

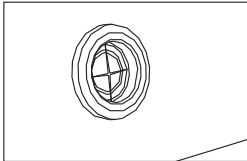

Gash the middle of the film of the power cord jacket with a sharp knife in order to put into power lines.

Step 4

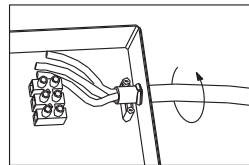

Screw the power cord into the jacket for installation of wire pressing plate.

Step 5

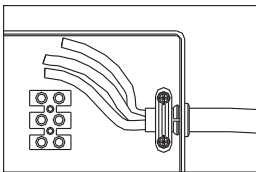

Tighten the wire-pressing plate with screws to primary position, ensure that the power cord not be pulled out more than 60N.

Step 6

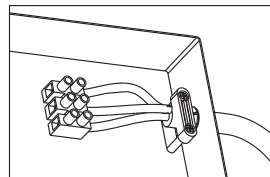

Connect the power cord to wiring terminals; the method is as shown in picture.



NOTE

The installation position of neutral line (blue), live line (brown/red) and earth line (green/yellow) should be corresponding to the other end on wiring terminals.

3.3 Water Heater Installation

- ① Determine installation position of the unit according to length of power cord / position of air switch (Distance between bottom and floor should be $\geq 1.6\text{m}$).
- ② Make sure the distance between the unit and surrounding wall is not less than 300mm, so that to have enough space for maintenance purpose.
- ③ Determine the position of four fixing screws (attached with the unit), make four holes with corresponding depth in the wall by means of a drill and drive a wall plug into the hole.
- ④ Drive in the screws on the top and ensure certain distance between screw head and wall (See Fig.1)
- ⑤ Mount the unit on the wall and tighten with four screws at bottom, connect the wires and install top cover with the screws.

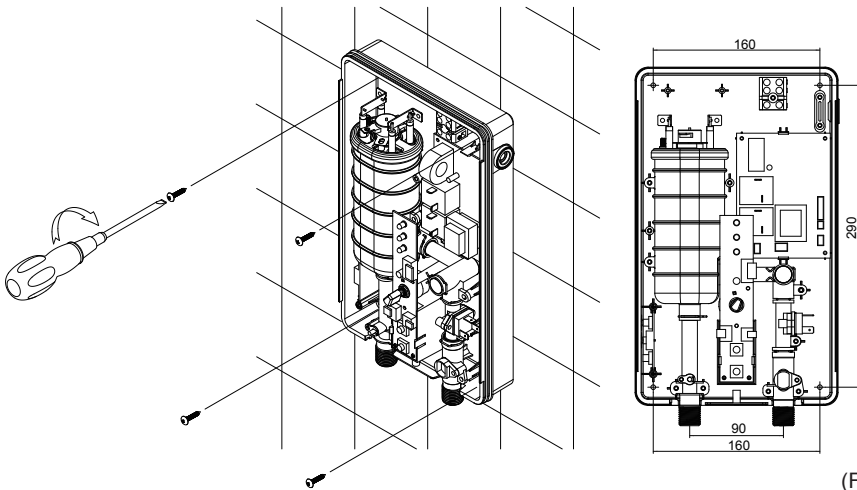

(Fig.1)

3.4 Plumbing Connection

- ① Water valve with filter should be installed at water inlet of the unit, sealing ring with filter should be used at end face. (See Fig.2).
- ② Shower flexible tube should be connected with water outlets and shower head separately, attached sealing ring should be used at end face.



WARNING

Metallic / chromed hose and conductive control valve shall not be used.

✓ Correct installation

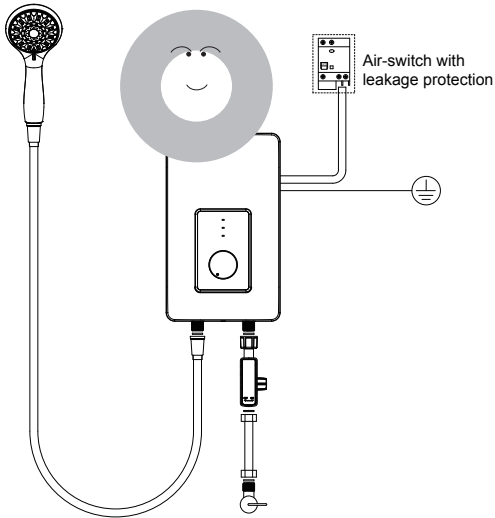

✗ Wrong installation

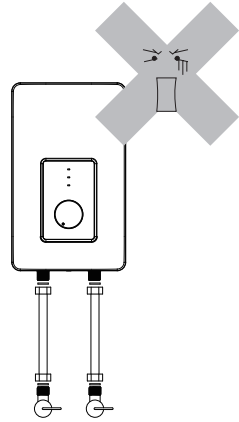

(Fig.2)



NOTE

It is prohibited to close the water outlet using a valve or restrict water flow by other means or devices. The water outlet should always remain opened ensuring free continuous to avoid the water heater damage, leakage and security incidents !

3.5 Power Supply Connection

- ① Adjust power selection knob to "OFF";
- ② Choose air switch with leakage protection according to power of water heater;
- ③ When connecting the water heater to electric network, please pay attention to connect live line (red/brown), neutral line (blue) and earth line (yellow/green) with corresponding line in electric network.



NOTE

A private power cord should be used for this unit. After connecting to electric network, please check the earth condition and make sure the earth resistance is $<4\Omega$.

3.6 Water Supply

After all the plumbing is finished connecting, open water inlet valve of the product and supply water to the unit to drain away air inside until there is stable water flow comes out from shower head. Check whether there is leakage at joints or not. If there is, check whether the connecting parts are fastened or not, then re-supply water.

4. METHODS OF USING

4.1 Operating Of The Unit

Switch on the power supply, the unit will take self-inspection for 2s, ELCB green indicator light will be on (under the condition of no electricity leakage). When the water flow exceeds 1.2L/min, rotate the knob clockwise to switch on heating power rotate switch, heating indicator light will be on, the unit start to work.

4.2 Leakage Testing

When the water heater is working normally, press TEST button, if the leakage test circuit is no problem, ELCB green indicator light will be off, and the unit will not heat. Press RESET, testing will be canceled, and ELCB green indicator light will be on, the unit will be back to working state set before. If the circuit leaks, press RESET button can't cancel leakagetesting, "ELCB" and "HEATING" indicator light is twinkling flicker, it means the water heater has problems and can't be used; all the buttons are invalid, heating is stopped, and pump will be closed.

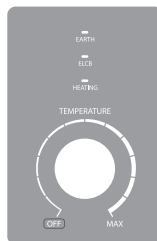

4.3 To Adjust Water Flow

Rotate the handle of water flow adjusting valve to adjust the water flow.

4.4 Electricity Leakage Protection

When the electricity leakage testing circuit is working normally, if the leakage current is bigger than certain value between 7.5mA and 15mA, the HEATING red and ELCB green indicator light will be off, no heating; it can only be used after the failure is excluded. (When electricity leakage is tested, "ELCB" and "HEATING" indicator light will be twinkling flicker, stop heating)

4.5 To Adjust Water Temperature

Rotate the handle of water flow adjusting valve to adjust to proper water flow. Adjust power by rotating knob, clockwise rotate, power will be increased and water temperature increase accordingly or vice versa.

4.6 Use After Overheating Protection

If the water flow is small and power is high while using the unit, outlet water temperature is rather high; the unit will stop heating automatically. At this time, please lower the power and adjust the water flow faster in order to avoid inconsistency of water temperature.



NOTE

For first time using, ensure electrify after the unit is filled fully with water and there is stable water flow comes out from shower head.

The electric water heater may be damaged if the water hardness is too high. To guarantee the normal service life, please install and put it into use on condition that the local water hardness is less than 450mg/L (CaCO₃).

5. MAINTENANCE

- This electric water heater should be installed at the place without sunshine or rain spray. Please cut off power supply if not use for long time.
- Please blow down the water for about 10 seconds to drain away the impurities in the pipe before connecting the water source to the electric water heater to avoid blockage of water heater.
- If long time no use the unit, check the water heater first before use. Electrify after the water flows out stably.
- Do not spray water to air switch or heater body directly, to avoid moist.
- Please cut off the power in the weather of thunder and rain to avoid damaging the water heater.
- If not use for long period of time, please cut off water inlet to prolong the lifespan of the water heater.
- Check the power cord connecting terminals frequently to make sure that they are well and reliably contacted, no overheating phenomenon, and grounding is good or not.
- Disassembly shower head and sealing ring with filter to clean periodically.

DECLARATION: this water heater can only be maintained by authorized service personnel, incorrect installation and using method may cause serious injury or loss of property.



WARNING

Do cut off power supply before maintenance, to avoid danger like electric shock.

6. TROUBLESHOOTING

SYMPTOMS	REASONS	SUGGESTIONS
Switch on the power supply, ELCB indicator light is off.	<ol style="list-style-type: none"> 1. Power supply error; 2. PCB error; 3. Thermal cut out acts. 	<ol style="list-style-type: none"> 1. Check whether power is cut. 2. Contact authorized service personnel for repair.
The heating indicator light is off and the outlet water is cold.	<ol style="list-style-type: none"> 1. The "TEMP" knob is off; 2. PCB error; 3. The water flow insufficient 1.2L/min; 4. Impurities clogging the flow sensor of the rotor. 	<ol style="list-style-type: none"> 1. Rotate "TEMP" knob 2. Repair or replacement the PCB. 3. Adjustable water flow. 4. Change the flow sensor. 5. Open the flow sensor and clean the rotor.
The heating indicator light is on and the outlet water is cold.	<ol style="list-style-type: none"> 1. The Silicon control is cut off. 2. Heating elements is broken. 	<ol style="list-style-type: none"> 1. Press the reset handle of the Silicon control after checking and troubleshooting. 2. Change the heating elements.
No water flows out from the shower head.	<ol style="list-style-type: none"> 1. The running water supply is cut off; 2. The inlet valve of running water is not open. 	<ol style="list-style-type: none"> 1. Wait for restoration of running water supply; 2. Open the inlet valve of running water.
Outlet water temperature sometimes is hot, sometimes is cold.	<ol style="list-style-type: none"> 1. Water pressure is not stable. 2. Outlet water temperature is too high, overheating protection again and again. 	Adjust the heating power lower, make the water flow bigger
"ELCB" and "HEATING" indicator light is twinkling flicker at the same time	Electricity leaks.	Contact authorized service personnel for repair.
"HEATING" indicator light is twinkling flicker	Temperature sensor is broken.	Change the temperature sensor.

The product is subject to change without notice.
Please keep this manual properly.