

TOSHIBA

TOSHIBA SUPERHEATED STEAM OVEN For Household Appliances

Instruction manual

Model name

ER-TD5000HK

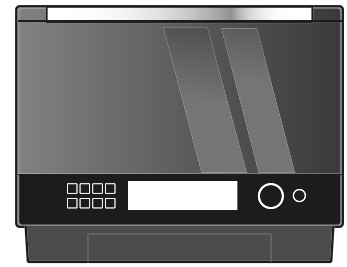

ER-TD5000C

ER-TD5000SG



- Thank you for purchasing Toshiba microwave oven with superheated steam oven.
- In order to use the product safely, please read and understand all the instructions manual and Cooking book, before using the unit.
- After reading, please keep the instruction manual handy.
- Please ensure you obtain the warranty card for this product.

First of all, be sure to do the following steps!

STEP 1 Read "Safety precautions" (Page 2~8)  
 * Things that must always be complied to are written down here. 

STEP 2 Insert the power plug 

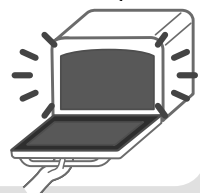
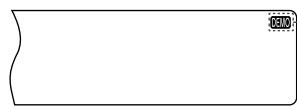
STEP 3 Open/Close the door (Page 10) 
 The oven turns on when you open the door
 **DEMO** is displayed when it is in demo mode. Please use after cancelling. (See "when this display shows" on page 57)

STEP 4 Heat empty oven (Page 18) 
 * As the inside of your oven will become hot, please use it after it cooled down.

Once step **1** ~ **4** have been done

Let's start cooking! Please read pages 14~17 and 20~21, then start cooking.

- Warming up rice and side dish ... Pages 22~24 • 32
- Boiling vegetables Pages 28 • 31
- Warming up milk or alcohol ... Pages 26 • 27
- Warming fried food crisp Pages 28 • 32
- Defrost meat or fish Pages 28 • 30

* We have described a selection of warm-ups well used in everyday life. For others and details, please see the table of contents on the right page.

When heating with microwave oven

- Don't use square tray, deep tray, gridiron. Instead, please put the food directly in the oven
-  icon will appear on the display screen



Put the food inside directly without anything else!

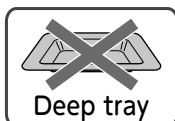

When heating with heater

Move small animals to another room, and ventilate the room!

- Especially at the beginning, smoke and smell may come out when you're heating the empty oven and burning off the oil.

- Please move animals which are sensitive to smoke and smell (ex. small birds) to another room, then turn on the exhaust fan or open the window.

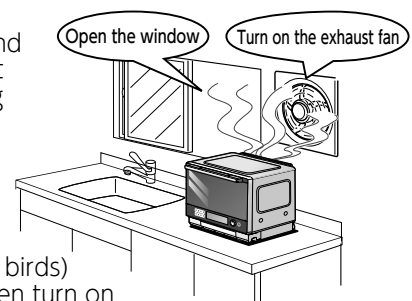



What should I do?

Warming up

Only one touch to start **REHEAT**

Moist and hot **Steam Reheat**

In addition to that... Adjustable **Desired Temperature** Handy and convenient **Microwave**

90°C **Plus + Steam**

★Softening butter
★Making frozen stiff ice cream easier to eat

Quickly giving moisture **Steam microwave**

-10°C

Roasting

Quickly roasting at high temperature **Max. 350°C Convection**

High heating steam to cut out extra oil **Max. 300°C Superheated steam**

Strong heating power from above to brown the surface of food **Grill**

For those who take care of their body... **Healthy cooking**

Pull out the flavour with the oven! **Plus Hybrid**

Steamed

Steam cooking with plenty of steam **Steamed**

Cooking with difficult heat levels are **Low Temp. Steam**

Low temperature cooking to make the most of the ingredients

※Aspects of inside of oven and images are for illustrative purposes only.

Here are the images and their meanings in this book.

Display

Lighting Microwave Flashing Microwave

Menu to use steam

Steam

Table of contents

Preparation and confirmation

Safety precautions	2~8
Parts name and Functions	9~13
Heating mechanism	14.15
Vessels you can use / Vessels you can't use	16.17
Heating empty oven / Deodorizing	18
"REHEAT" recommendations	19
When heating with microwave	20.21

How to cook

Automatic cooking	
Warming up rice and side dish	22
Tips to use well "REHEAT"	23.24
NON-FRIED / HYBRID, Deep tray menu, quick and easy cooking	25
Warming up milk or alcohol	26
Tips to use well "BEVERAGE"	27
Cooking with the dial menu	28.29
Tips to use well the dial menu	30~33

Manual cooking	
Heating / Stew with microwave	34.35
Warming up at the desired temperature	36.37
Cooking with CONVECTION	38.39
Ferment	40
Cooking with GRILL	41
Cooking with steam (STEAMED / STEAM MICROWAVE / LOW TEMP. STEAM)	42.43
Cook with SUPERHEATED STEAM / HYBRID	44.45
Reference for manual heating's setting time	46

In the following situations

About the notification sound (buzzer sound)	47
How to do maintenance	48~51
Common inquiry	52
In case you can't cook well	53~56
Meaning of indicators and what to do	57
Before asking for repairs	58.59
Specification	Back cover

* Please see the separate recipe collection for recipes.

Safety precautions

Please make sure to follow these instructions for your safety

- Important contents are mentioned to avoid injury to any person or damage to any property, and to use the product correctly and safely.
- Mentioned the sectioned degrees of injuries and damages which can occur in case you're using the product without respecting the safety precautions.
- Mentioned the instructions you should follow, classified by symbols.

DANGER

Matters which have great risk of causing "serious injuries" or "death".

WARNING

Matters which can cause "slight injuries" or "damages to your house / property".

CAUTION

Matters which have possible risk of causing "serious injuries" or "death".



"Forbidden" matters you should never do



Matters "you should follow the instructions of"



Matters "you should pay attention to"

IMPORTANT SAFETY INSTRUCTIONS READ CAREFULLY AND KEEP FOR FUTURE REFERENCE

The oven contains high voltage parts

DANGER



Dismantling is forbidden

Do not dismantle / repair / modify the product yourself

It may cause fire / electric shock / injury. For any repairs, please contact the shop where you purchased the product or Toshiba's support center for home electric appliances.

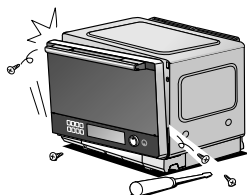

Forbidden

Do not insert fingers, a foreign body, or a metal object like a pin or a wire inside the product's inlet port, exhaust port, water supply cassette's delivery port, or other holes.

It may cause electric shock / injury. In case of any foreign body comes into the product, please pull out the power plug and contact the shop where you purchased the product or Toshiba's support center for home electric appliances.

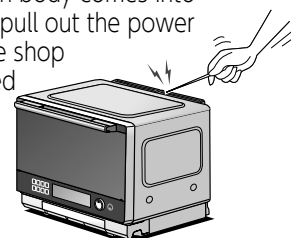

Manipulation of power plug / power cable / electrical outlet

WARNING



Exclusive power supply

Make sure for connect the microwave oven to an exclusive power supply of the related voltage.

Sharing power supply with other appliance or use of extension power cord, may cause fire and electric shock.



Forbidden

Do not use damage power cord, power plug or loose plugs

If the supply cord is damaged, it must be replaced by the manufacturer, its service agent or similarly qualified persons in order to avoid a hazard. It may cause fire / electric shock.



Please make sure you fully plugged the power plug into the outlet.

It may cause electric shock and/or fire due to heat developed.

Manipulation of power plug / power cable / electrical outlet (Continued)

! WARNING

Forbidden

Do not damage the power cord or the plug

If you work on it, put it close to a high temperature area such as vents, forcefully bend, twist, bundle, place a heavy item on it, etc. the cord may break causing fires or electric shock.



Forbidden on wet hands

Do not remove the power plug with wet hands

It can cause electrocution.



Pull out from electrical outlet

If you'll not use the product for a long period of time, pull out the power plug from electrical outlet

Or else, it may cause electric leakage fire due to insulation deterioration.



Forbidden

Do not operate if the door are damaged.

If the door or door seals are damaged, the oven must not be operated until it has been repaired by a competent person.



Clean up the dust

Clean up regularly the dust on the power plug

If dust collects on power plug, it may suffer insulation failure due to dampness, and it may cause fire.



Pull out holding the plug

When you're pulling the power plug out from an electrical outlet, hold the power plug while pulling it out

If you hold the power cable while pulling the power plug out, it may damage the power cable and cause fire / electric shock.

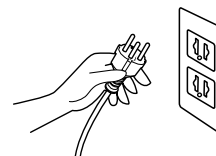

MICROWAVE ENERGY

Hazardous when carry out any service.

It is hazardous for anyone other than a competent person to carry out any service or repair operation that involves the removal of a cover which gives protection against exposure to microwave energy.

When installation the product

! WARNING

Remove the packaging material

Remove all packaging material before using the product

If you don't remove them, they may ignite during operation and cause fire / burn.

**Keep packaging plastic bag out of young children's reach or dispose of them**

If young children wear a packaging bag on their head, it may obstruct their mouth and nose and cause asphyxiation.



Forbidden

Do not move flammable or heat-sensitive substances closer to the machine body**Do not move spray can closer to it**

It may cause burnt deposit / fire.
Spray may ignite and explode.

Do not put it on tatami mat, carpet, or table cloth, and do not move curtains closer to it. If you put the product's exhaust slot close to heat-sensitive furniture, walls with an electrical outlet, or heat-sensitive walls, they may suffer thermal deformation. So please keep them away the product.

When installing the product (Continued)

! WARNING



ALWAYS
CONNECTED
EARTH

Always use the power outlet with earth socket.

For safety, connect the power plug to power outlet with earth socket only. Otherwise, it may cause electric shock.

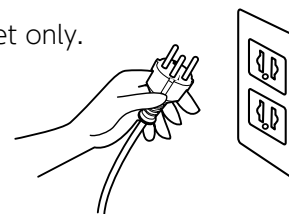

- Inspect the microwave regularly. If door leakage protector is broken, do not operate the microwave until a proper repair by professional.
- Do not perform repair that need to uncover leakage protector without professional. Otherwise, it may cause a severe injuries.
- Observe the microwave when operating with plastic or paper containers. It may cause fire.



Forbidden

Do not use in environment close to water drops, steam emitting machines and fire.

It may cause fire / electric shock / electric leakage.

! CAUTION



Leave space
between
the product
and the wall

Placing the product with a space between it and the wall

It may cause fire due to overheat. There is an exhaust port from the inside of the oven at the rear upper part of the product.

- When there is a wall which is weak to heat, consumer electronics, furniture, electric outlet, please leave a space equal or superior to the dimensions on the right. Depending on the wall's material, the machine body may create contact traces on the wall. Also, if there is an electric outlet close to the exhaust port, or when you are worried about dirt, please leave a space equal or superior to the dimensions on the right in order to avoid direct contact with the exhaust air.
- When there is a glass material backward, as it may cause risk of cracking due to the difference of temperatures, please leave a space equal or superior to 20cm. (Glass may crack due to the difference of temperatures even with the space)

(Conformity to fire protection law standards Built-in type)

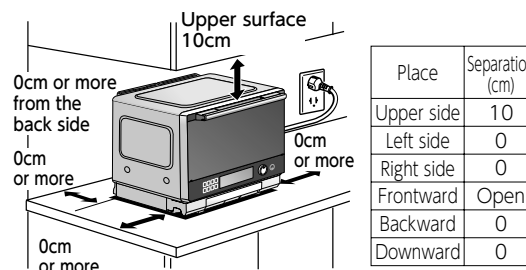

- If you're worried by the dirt on walls due to exhaust air or by the impact of steam, you can reduce the dirt on walls and the impact of steam by increasing the distance with the wall or put aluminum foil on the surface of the wall.
- If you plan to frequently cook in such a way that oily smoke is produced such as frying fish, we recommend that it is placed in a location where the top can be released from the main body.



Place
on a flat
place

Put on a flat place which is strong enough

If you put the product on a table without enough strength, it may fall or collapse and cause injuries. Also, dew condensation water may slop over the floor. In case it toppled down / fell due to earthquake or other, please leave the product without using it and ask the shop where you purchased the product a check. Overturning prevention metal fixture to avoid the machine body's fall / topple.

While using

⚠ WARNING



When you see something unusual or broken, stop using immediately

When there is something wrong, stop using

The oven might start fire, smoke or the user might get electric shock.

<Example of abnormality, broken>

- The power cord or the plug gets very hot.
 - Strange sound or smell comes out while using.
 - The power sometimes does not go off automatically.
 - You sometimes see sparks or smokes coming out.
 - The door does not shut tight or is deformed.
 - You feel electricity when touching the oven.
- Please unplug and ask the reseller for checkup and repair.

If smoke is observed, switch off or unplug the appliance and keep the door closed in order to stifle any flames.



Do not pull out and put back the power plug while cooking

Forbidden

It causes sparks and could lead fire and electric shock.



Forbidden

The appliance is not to be used by persons (including children) with reduced physical, sensory or mental capabilities, or lack of experience and knowledge, unless they have been given supervision or instruction. Children being supervised not to play with the appliance.

When the appliance is operated in the combination mode, children should only use the oven under adult supervision due to the temperatures generated.

Do not leave a child and those who do not know how to use to use the oven by themselves. And don't use it within infant's reach. Especially, while heating the oven or just after heating, never take your eyes off from your children. They might get electric shock, injured, or burnt.



Do not block the intake port and exhaust port.

Forbidden

It causes the fire.

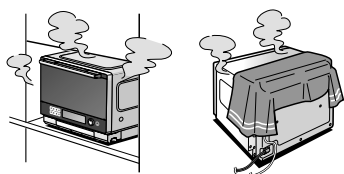

Forbidden

Do not use for other purpose than cooking

By overheating or abnormal operation, it might cause burns, injuries, breakages, or fire. Do not heat objects like clothes, towels, hot-water bottles sold for heating in microwaves, feeding bottles (disinfection bag), heating pads, or warmer for the bath tab.



Forbidden

Do not put an object on top of the oven or cover with cloth.

The object on the oven gets hot and might cause deformation, burnt, or fire. Do not put oven's accessories such as the square plate, either.

During use the appliances becomes hot. Care should be taken to avoid touching heating elements inside the oven, for cooking ranges and ovens

Accessible parts may become hot during use. Young children should be kept away.



Forbidden

Do not put too much pressure to the door or inside of the oven Do not hang to the door or ride on the door

It will cause deformation of the door and might cause damages to human bodies by the leaked electric waves.

Also, by hanging to the door or riding on the door, the oven might tip over or fall, which might cause injuries.

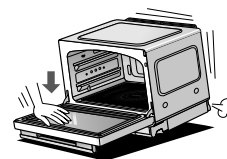

⚠ CAUTION



Forbidden

Do not jam objects in the door while using

The leaked electronic wave might cause damages to human bodies or start fire.



Forbidden

If food burns in the oven, do not open the door

By opening the door, the fire gets bigger and can cause more damage.

- Please handle if food burns:
 - ① Press "Cancel" key with door shut and stop the operation.
 - ② Pull out the power plug.
 - ③ Keep burnable items away and wait until the fire gets put out.
 - ④ If the fire doesn't get put out by itself, use water or fire extinguisher.
- Do not try to use again. Call the reseller for checkup.



Forbidden

Do not hit corner plates, base of the inside or the glass in the door with objects or impact it

When putting in or taking out containers or bowls, please be careful not to hit it against the base or the door glass. If the glass is damaged, it may crack during use.



Caution

When closing the door, be careful of the dent for the fingers

It may cause burns or injuries.



BABY FOOD

Stirred and temperature checked

The contents of feeding bottles and baby food jars shall be stirred or shaken and the temperature checked before consumption, in order to avoid burns.

While microwave heating

WARNING



Do not overheat foods

Longer cooking time for the food portion, it will cause smoke and fire.

Forbidden

- For manual heating, set moderate duration by referring the setting time on page 46 while checking the food inside carefully.
- Especially, please be careful with following foods: small portion, food with oils (bread with butter, fried foods, etc.), food with less water (popcorn, etc.), root vegetables (sweet potatoes, carrots, etc.), foods tend to get hot (red bean buns, etc.).
- For automatic cooking, please follow the contents in the instruction manual in regard to portion, container, plastic wraps, etc.



Do not heat food less than 100g※ automatically

Since the food temperature is not properly detected, food gets overheated and might cause fire.

Forbidden

- Please heat manually while checking the food inside carefully.
- ※Automatic cooking "Rapid defrost" or "Steam Defrost" is for less than 50 g



Do not use heating cook with infrared sensor for containers with lids (Page 20)

With lid, the food temperature cannot be properly detected, food gets overheated and might cause fire or the container might break.

Forbidden

- Please remove the lid before heating.



Empty foods in can, jar, or bag, retort food, and vacuum-packed food in other dish Remove freshness-keeping agent (oxygen absorber)

They may cause fire, explosion, damage to the oven, injury, and burn.



When heating baby foods and nursery foods, mix well and check the temperature after heating

The food may cause burns.



Liquids and other foods must not be heated in sealed containers since they are liable to explode

Remove PACKAGING



When heating food in plastic or paper containers, keep an eye on the oven due to the possibility of ignition.



Do not overheat drinks, oily foods, etc.

It may boil suddenly when or just after taking it out and may cause burns. Also, by putting powder like instant coffee may make the liquid boil suddenly.

Forbidden

Microwave heating of beverages can result in delayed eruptive boiling, therefore care must be taken when handling the container.

- Do not heat drinks with "REHEAT" key. Heat milk or alcohol with the "BEVERAGE" key. For other liquids like coffee and water, follow the instructions on page 46 and set moderate duration and heat up manually.
- If overheated, leave the food inside the oven for more than 2 minutes and take it out after cooled down.
- Use shorter, wider mouth container.
- Follow the contents in operation manual with regard to the portion, container, placement, etc.
- Mix drinks with spoon or other tools well before and after heating.

Explosive boil



Drinks: liquids like coffee, milk, soy milk, water, yogurt, soups like miso soup
Oily foods: fresh cream, butter, etc.
Thick foods: curry, stew, etc.



Do not cook raw eggs, boiled eggs (with or without shells), sunny side up

The egg may break and cracking of the base inside due to impact may cause injuries or burns. It can suddenly break after removal.

Forbidden

Eggs in their shell and whole hard-boiled eggs should not be heated in microwave ovens since they may explode, even after microwave heating has ended.

- Scramble eggs very well before heating.
- Do not warm up boiled eggs (within dishes like Oden, chop suey).



Remove lids from high sealing containers, cut or crack foods with skin, shell, or film (squid, chestnuts, ginkgo, etc.)

Remove lid cut shell

They may break and damage the oven, cause injury or burns.

Only use utensils that are suitable for use in microwave ovens

CAUTION



Do not heat without anything in the oven
It may cause sparks, or the body or inside of the oven gets heated abnormally and leads high temperature, which may cause burns. Also, heating long duration or small portion makes inside of the oven hot and may cause burns. Please do not touch inside of oven right after heating.

Forbidden



Be careful when taking out dishes or foods and when removing plastic wraps

When it's hot, steam may come out immediately, which may cause burns.



Do not use containers and bags that has been finished with metals such as the square plate, wire net, aluminum foil, metal container, metal skewer, metal rope, aluminum tape, aluminum

Forbidden

It may cause sparks and the bottom of the oven or door glass breaks and may lead injuries.

While heating heater and steam heating

⚠ CAUTION



Do not touch

Do not touch hot parts (inside the oven, door, body, exhaust port, water supply cassette) and taken out square plate during and after cooking.

Due to the high temperature, it may cause burns.

- Please discard water in water receiving part after it gets cooled down.
- Do not place square plate on places not resistant to heat after cooking. It may cause deformation and discoloring.



Use thick commercially available mittens when putting and taking out foods and accessories

If you touch them directly, it may cause burns and injuries. Moreover, please do not use oven gloves that have broken or that are wet.



Forbidden

Do not put your face or other body parts close to the door during or after cooking

It may cause burns.

During and after steam heating, please be careful with heat and steam. Please be extra careful when opening the door as hot steam may come out.

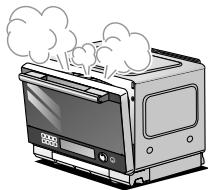

**Change water in water supply cassette for every use
Discard water in water receiving part after every use**

It may cause mold and bacteria to grow.

- Please always use fresh water when cooking. Please discard water in water receiving part after cooking.
- Since it may be hot, please wait and discard water in water receiving part and rinse it.



Move small animals

While heating heater, move small animals, such as small birds, that are sensitive to smoke or smell to another room. Turn the extractor fan or open the window for ventilation

Especially when baking for the first time to deodorize and burn oil in the oven, smoke and smell tend to happen.

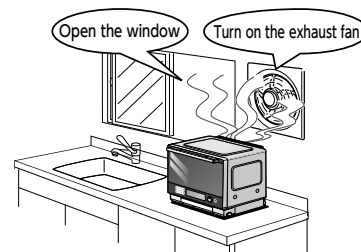

Forbidden

Do not use the water supply cassette if it is broken

It may cause injury.

If there is crack or chip, do not use the oven and consult the reseller.



Be careful with steam

Be careful with the remaining steam to be generated while or after steam cooking

Opening and putting hands into the oven right away can cause burns and injuries. Please be careful if you have opened the oven while cooking as steam may keep coming out for a while.

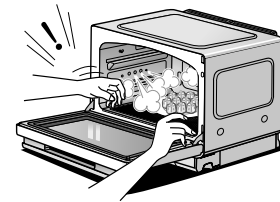

Forbidden

Do not put your hands close to the left side of the inside of oven and steam outlet

It may cause burns.



Prohibit on water

Do not put water to the door, inside of the oven, square plate or cool them down suddenly during and after cooking

It may cause crack and you may get injured or it may deform.

Also, generated steam or hot spray may cause burns.

Maintenance

WARNING



Unplug and
cool down

Unplug the power plug and let the machine body cool down before cleaning the body.

Or else, it may cause electric shock or burns.



Forbidden

Do not heat while oil, food particles or water exists inside of oven

The electric wave focuses on the dirty part and may cause sparkle, smoke, and fire.

- If something sticks, please wipe it off after the machine body is cooled down.

- Do not use harsh abrasive cleaners or sharp metal scrapers to clean the oven door glass since they can scratch the surface, which may result in shattering of the glass.
- Shall state a steam cleaner is not be used
- The appliance shall not be cleaned with a steam cleaner.

CAUTION



Leave the door closed whilst removing water from the pipe

Steam is generated during water removal from the pipes in the same way as during steam cooking. It may cause burns hence leave the door closed.

The oven should be cleaned regularly and any food deposits removed.

Failure to maintain the oven in a clean condition could lead to deterioration of the surface that could adversely affect the life of the appliance and possibly result in a hazardous situation.

Notes

Keep at least 4m away from devices such as TV, radio, wire antenna.

It may cause the images and sound to be disrupted.

Wireless LAN devices' communication capability may reduce near the product

Please use upon reading the instruction manual for the wireless LAN devices.

Keep away from heat and steam

Please make sure the steams from devices such as rice cooker and electric kettle will not be sprayed on the oven. It may cause damage.

Please used in a position where it is not affected by water vapour.

Be careful when moving the machine body

Please hold the bottom of left and right side of the product and move.

It is a heavy product so we recommend that two people hold the sides to carry it.

Moreover, when placing the product in the place of instalment, please be careful not to damage the surface of instalment via the corner of the base of the product, etc.

Parts name and Functions

Preparation and Confirmation

Safety precautions / Parts name and Functions

Body

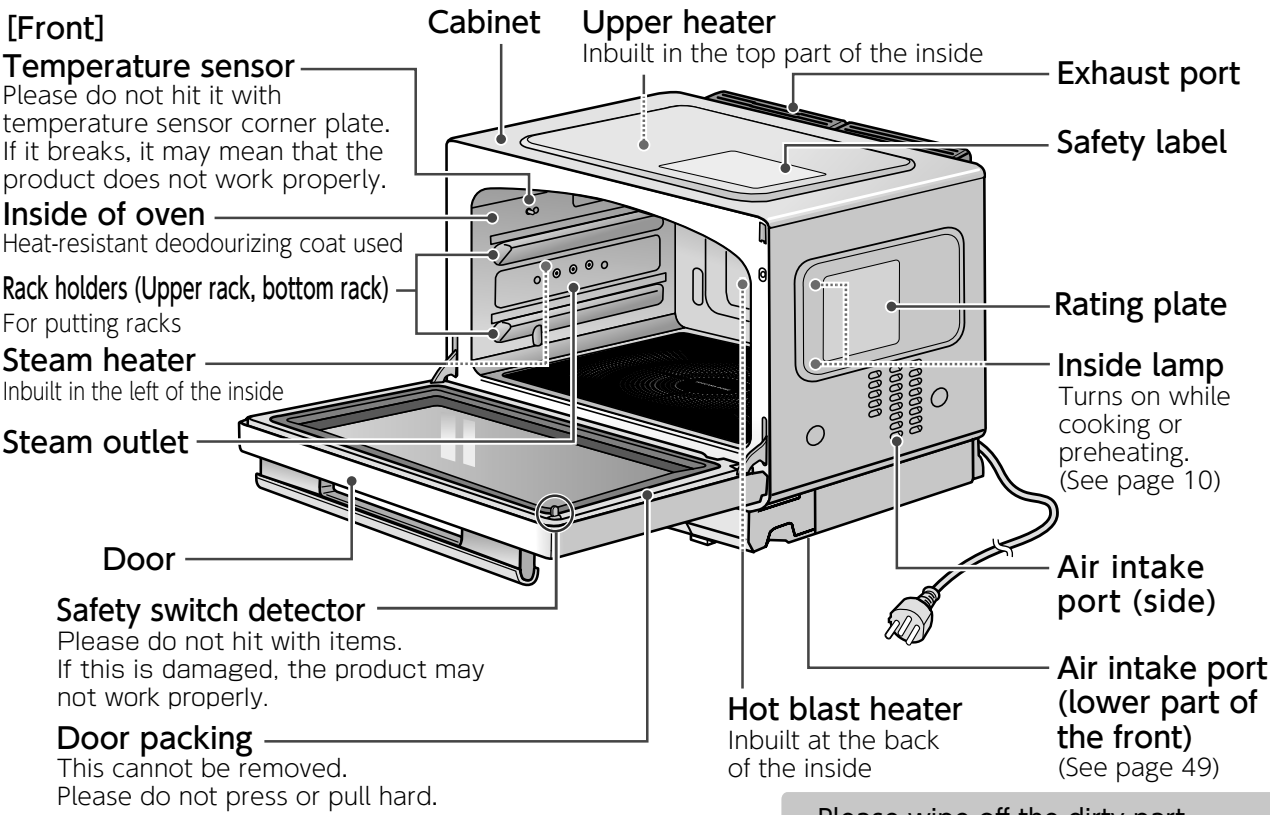

- Please wipe off the dirty part immediately.
- Please wipe clean any dirt inside. As it's highly adhesive, water may accumulate inside.

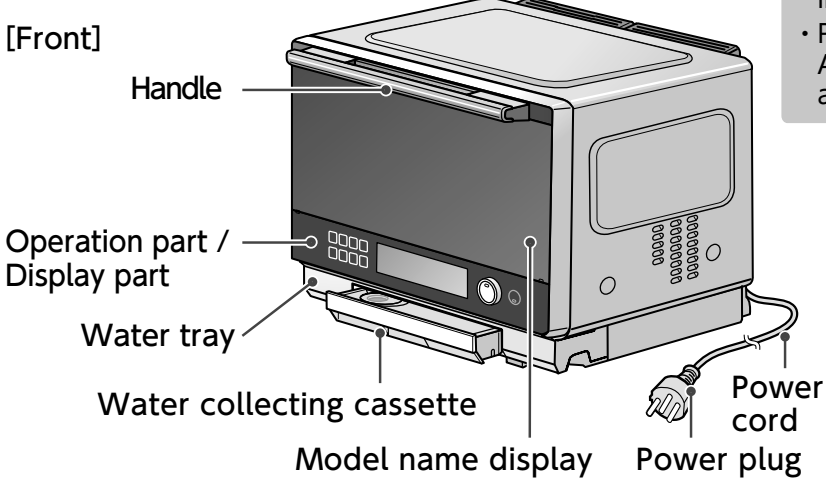

Accessories Please use accessories properly

• Do not use accessories in other devices or for other purposes other than for this microwave oven.

2 x Square Tray (metal) 1 x Square Tray (deep)



- Used for oven, grill cooking, steamed, Low Temp. Steam or fermentation
 - ※It cannot be used with microwave oven heating cooking due to sparks being triggered. **【For Easy baking's Fermentation, etc.】**
 - ※Please do not to cool down immediately after using. It may cause damage or deformation.
 - ※Square tray (metal) is not flat in order to prevent heat deformation.
 - ※If you hit a square plate strongly on the inside or rub it, the pain may be damaged.

1 x Gridiron

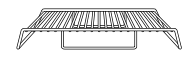

- Use it by putting it on top of a square tray (metal) for oven, grilling, steamed, Low Temp. Steam, warming crisply, etc.
 - ※Sparks may fly with microwave oven heating cooking hence cannot be used.

Parts name and Functions (continued)

Operation parts

Dial menu (Automatic menu 4 ~ 51)*

Just select a menu. Automatic menus don't require setting of temperature and duration.

* Automatic menu (4~51) can be selected by turning the dial. 4~17 can be selected using the touch menu keys too. Menu number is displayed in the display area so please use it in conjunction with the number of the menu to be used.

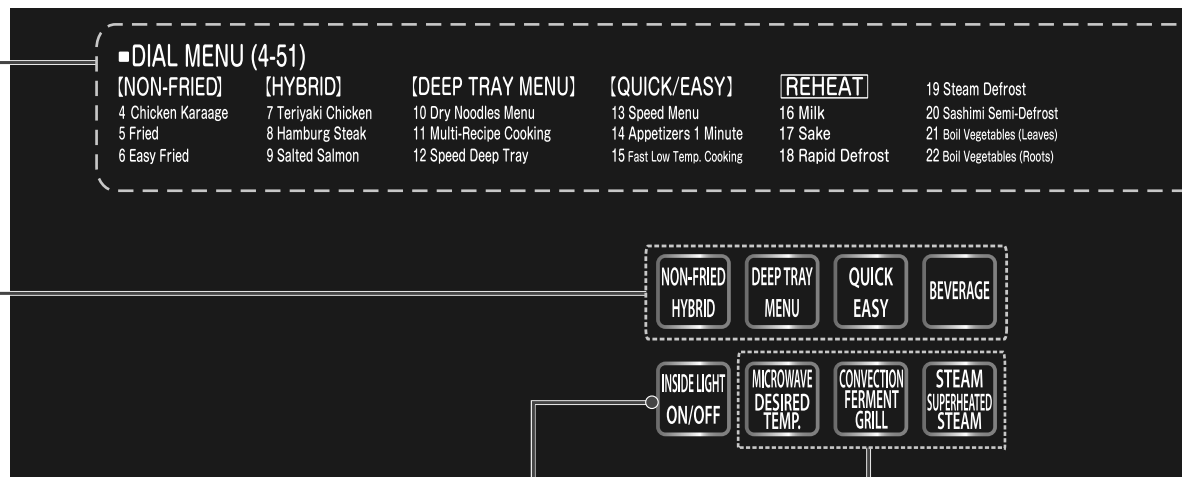

“Touch menu (Automatic menu)” key

Automatic menu (4~17) can be selected (Pages 25~27)

- Menu will switch every time you press.

Non-fried/Hybrid:

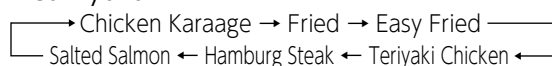

Deep tray menu:

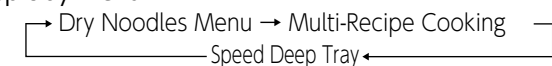

Quick/Easy:

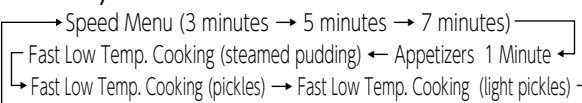

Beverage:

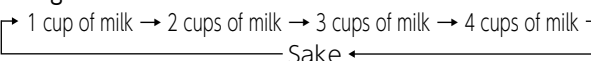

※A selection can also be made by turning the dial.

Manual cooking key

Set the duration and temperature according to cooking. (Pages 34~45)

“Inside light” key

The inside light can be switched off during cooking or switched on during pre-heating or switched on after the end of cooking.

Only when “extend” and “0” are being displayed during cooking, pre-heating and at the end of cooking, the lights flash and switch off alternately every time the key is pressed.

※No controls can be applied when the door is open.

● About the inside light

- It flashes when the door is opened and then switches off. (The time for which it flashes differs depending on the usage conditions)
- It flashes during cooking. It does not flash during the pre-heating.

Energy saving function

Automatic power off

The power automatically shuts off if the oven is not used.

■ If the door left shut/closed for more than 5 minutes while the display part shows “0”, the power automatically shuts off.

- While “High temperature” is shown, the power will not be shut off automatically

The power turned on when the door is opened

The display part shows “0” (Plugging the power plug only does not turn on the power)

Display part

Displays the automatic menu number, accessories to be used, temperature, time and heating types. (See page 12)

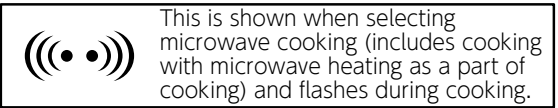

“Cancel” key

Used when canceling controls or settings or when discontinuing cooking.

- When checking during cooking, open the door without pressing any keys. It reopens if you close the door and press “start”.
- If cooking is not restarted and it is left as is for a while, cooking will stop automatically.

Automatic menu 1 ~ 3

See pages (22 ~ 24)

23 Steam Reheat	COOKING MENU	30 Steamed Egg	34 French Bread	38 Bagel	42 Chiffon Cake	46 Toast	CLEANING
24 Crispy Reheat	27 Salt Grilled Saury	31 Easy Bread	35 Butter Roll	39 Cookies	43 Fresh Chocolate	47 Toast (Frozen)	49 Quick Cleaning
25 Fluffy Bread	28 Grilled Fish (Slices)	32 Easy French Bread	36 Tomato&Cheese Pizza	40 Choux Cream	44 Baked Sweet Potato	48 Steam Toast	50 Water Removal
26 Steamed Bun	29 Gratin	33 Easy Pizza	37 Plain Bread	41 Sponge Cake	45 Cream Caramel	(46-48 Flipped Over)	51 Deodorize

1 Cooked rice 2 Sides dish 3 Two dishes

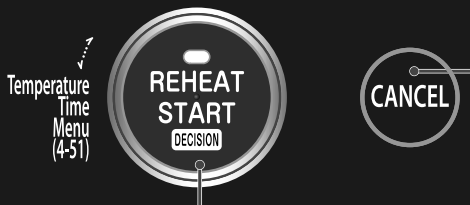

“Reheat” / “Start” key dial

• Used when warming meals or accompaniments (automatic menu 1 - 3 : pages 22 ~ 24), starting to cook, selecting automatic menu, setting temperature or duration, etc.

- Press : Warming up rice or accompaniments*, start cooking*, etc.
→ the “reheat” key does not operate more than one minute after the door opens or closes. (“Door open / close” is displayed)
Please press the “reheat” key after opening or closing the door again.
*Heating starts immediately when you press the key.
- Turn : Selection from automatic menu, adjusting temperature / duration, etc.

Automatic menu (4 ~ 51) : Select from the menu by turning the dial. (Pages 18, 28~33, 50~51)

• Finish : It can be set within 15 seconds after the start of cooking with automatic cooking.

3
2
1
Standard
1
2
3

Increase ← → Decrease

Manual cooking : Adjust the temperature and time by turning the dial.

- Temperature : If you turn it to the right, it goes up by 10°C and if you turn it to the left, it goes down by 10°C.
Low Temp. Steam / Desired Temp. goes up by 5°C when you turn it to the right and goes down by 5°C when you turn it to the left.
- Duration : If you turn it to the right, it goes up and if you turn it to the left, it goes down.

It will start if you press it when it is flashing.



Parts name and Functions (continued)

Display parts

Displays the automatic menu number, accessories to be used, temperature, time and heating types, etc.

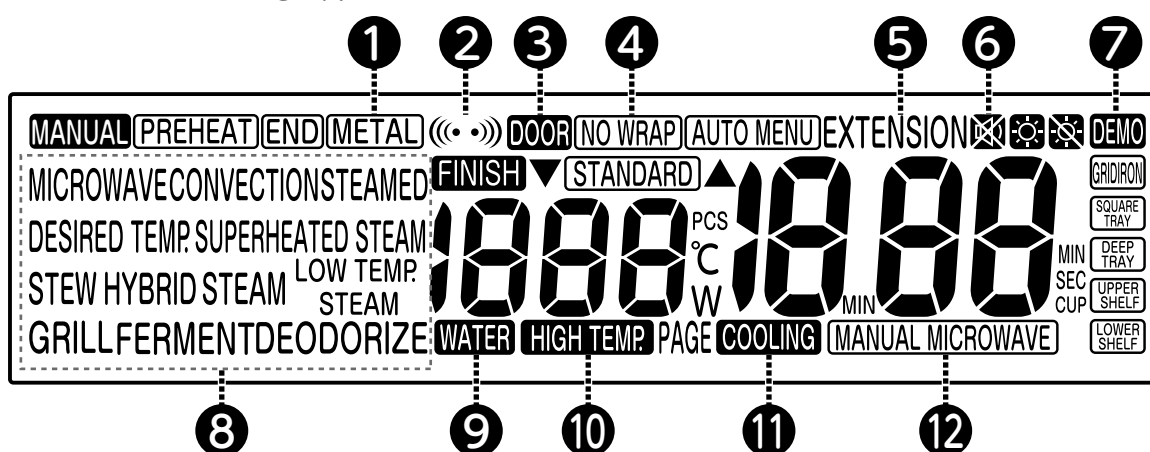

① METAL	It lights up when metallic containers or accessories should not be used such as with Microwave heating.
② ((••))	This is shown when selecting microwave cooking (includes cooking with microwave heating as a part of cooking) and flashes during cooking.
③ DOOR	It is displayed in the following situations. → “Meaning of indicators and what to do” Page 57 • When you close the door and press the “REHEAT” button after more than a minute. • When “start” button is pressed without opening or closing the door after buzzer sounds under an automatic menu where work is required during cooking. • When the door is not fully closed.
④ NO WRAP	When plastic wrap is not required for cooking, it flashes. Please still use plastic wrap for warming up frozen food or thick food.
⑤ EXTENSION	Heating time can be extended while this is displayed.
⑥	This is displayed when the setting is to cancel all buzzer sounds. → “About the notification sound “buzzer sound”” Page 47
⑦ DEMO	It is displayed when demo mode is set. → “Meaning of indicators and what to do” Page 57
⑧ Types of heating	Displays the types of heating or operating status. The display flashes during cooking.
⑨ WATER	During cooking that use steams, it flashes when no more water is left. → “Meaning of indicators and what to do” Page 57
⑩ HIGH TEMP.	Displays when the inside temperature is high after completion of cooking with heater heating such as with the oven. → “Meaning of indicators and what to do” Page 57
⑪ COOLING	It displays when electric parts, etc. are cooled by the fan after repeatedly using the Microwave heating or after the completion of using the oven or heating. → “Meaning of indicators and what to do” Page 57
⑫ MANUAL MICROWAVE	It flashes when manual microwave heating (600W, 500W, 200W, 100W, 900W, stew) can be done even the oven is cooling down after cooking.

Water tank · Drain tray

Water tank

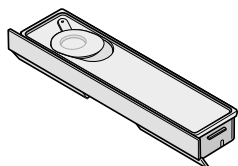

Container to put water to supply to steam. Set on the console even when not in use. At a capacity of approx. 360 cc, approx. 25 mins of superheated steam cooking and approx. 60 mins of superheated steam cooking is possible. The amount of water reduction differs depending on the course or the menu and there are cases when there is only a slight reduction such as with steam proofing or short term steam, etc.

Preparing water supply

■ How to add water

When cooking using steam, open the cap and fill with tap water up to the full water line.

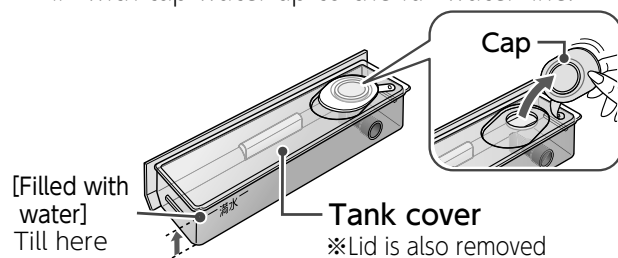

■ Inserting and removing

Push the water tank inside till it latches perfect

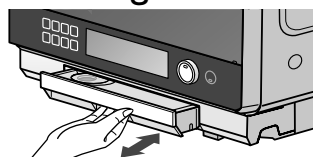

- Ensure that the cap and tank cover is closed properly.
- Always keep flat while in use because tilting causes water spills.
- Take care so that your fingers do not get caught while fixing

Drain tray

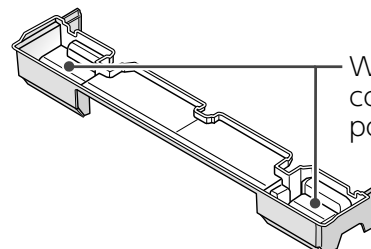

Water will be collected in this portion

A container to stores water required for steam cooking.

Even with Microwave heating, the moisture evaporating from food accumulates.

Keep setting on the main body even if steam cooking is not used.

Please maintain regularly. (See page 49)

■ Inserting and removing

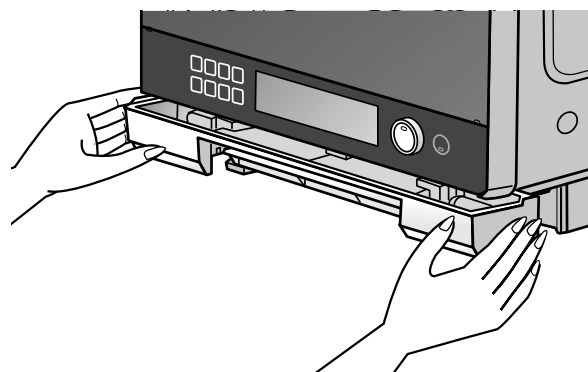







- Check if the setting is correct before cooking. If it's not set properly, it may cause a water leak.
- Please check that no water has accumulated before using steam.
- Water may have collected there so please be careful when taking it out.
- Please throw away the water each time after using steam.
- Take care so that your fingers do not get caught while fixing

When using  mode steam, refer to page 51 for about cleaning.



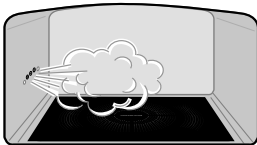







Notice

- When using the steam menu for the first time or when dirt accumulates due to prolonged non~usage, refer to page 50 for "How to clean with steam system".
- Ensure that the water tank and drain tray is always clean.
- After use, you must throw away the water remaining in the water collection cassette and new water should be used each time.
- Please use tap water. Please do not use hard mineral water, alkaline ion water or water from wells, etc. If hard water is used, chlorine (white powder) may appear and if it's used for a long time, steam vent may get blocked. If the chlorine is noticeable, we recommend the use of mineral water which is not hard water.
- When steam cooking, please ensure water is put in up to the full line on the water collection cassette and ensure it's properly set in the main body along with the water tray. If there is not much water and steam cooking is carried out with it half inserted, "WATER" is displayed in the display part and cooking may not go well.
- Do not fill the water tank with liquid other than water as it may cause damage.
- Care should be taken to ensure that the water is not at a temperature lower than 5°C. Water will freeze and steam will not come out.

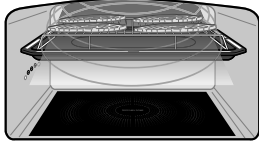
Heating mechanism

Heating mode		Heating mechanism	Heating point	Usable accessories Unusable accessories
Microwave heating	Microwave	<p>Heats with electric waves</p> <ul style="list-style-type: none"> ● Water molecules of food is led friction when microwaves hit, and generate heats. Thus, the food gets heated uniformly inside and outside. ■ Nature of radio wave <ul style="list-style-type: none"> Absorbed by food and moisture content It penetrates potteries or porcelains Metal containers, aluminum retort packs will reflect and cannot be used for heating 	<ul style="list-style-type: none"> ● The time should be balanced with the quantity of food. If the quantity of food is doubled, the cooking time should be almost doubled as well. ● The time taken is low as the moisture is absorbed and the food becomes dry. Preset the time to a shorter duration and observe the food when getting cooked. ● Please place food directly in the centre. 	<p>Accessories cannot be used</p> <p>Sparks may fly, potentially causing fire</p>  <p>Square tray</p>  <p>Deep tray</p>  <p>Gridiron</p>
	Desired Temp.	<p>Warm food until it reaches a set temperature</p> <ul style="list-style-type: none"> ● The final temperature of the food is detected by the Infrared sensors. 	<ul style="list-style-type: none"> ● Heating at a desired final temperature that -10 to 90°C. Baby food is cooked according to desired consistency of cream. ● Refer to page 37 to preset the oven to desired final temperature. ● Time is not set as heating is applied until the finishing temperature is reached. 	
	Microwave steam	Use microwave and steam for cooking.		
Steam heating	<p>Steamed</p> <p>Low Temp. Steam</p>	<p>Heats with steam (Microwave is not used)</p> 	<ul style="list-style-type: none"> ● Used for steamed dishes such as Chawanmushi. 	 <p>Square tray</p>  <p>Deep tray</p>  <p>Gridiron</p>

Please read cautions for safety "While microwave heating", "While heating heater and steam heating" (on page 6-7).

Heating mode		Heating mechanism	Heating point	Usable accessories Unusable accessories
Heater heating	CONVECTION	<p>The heater and the fan spread the hot air or super-heated steam everywhere and heats the food as though they are enveloping it.</p> 	<ul style="list-style-type: none"> ● Some food increase in size after cooking. Place food items properly. ● Observe the condition of food and adjust time as well. If the chamber still hot, may be repeated heating, set a shorter time and observe the condition of food. ● Do not open and close the door frequently. The temperature inside will decrease. ● During heating, rotate food or wrap the cooked part with aluminum foil. ● Take out the food immediately after cooking to prevent overcooking. <p>Due to the temperature in cooker, steam may not be visible. Especially, overheated steam is invisible.</p>	 Square tray  Deep tray  Gridiron Steam may not be visible to the eye depending on the inside temperature.
	Superheated steam	<p>CONVECTION...</p> <ul style="list-style-type: none"> ● Due to the functions of heaters and fans, it makes heated steam or heat wave pervasive, and heat as if wrapping food. 		
	Hybrid	<p>Superheated steam...</p> <ul style="list-style-type: none"> ● Gas after heating steam (colourless and transparent) is very effective at heating and heats up food quickly. <p>Hybrid...</p> <ul style="list-style-type: none"> ● Super-heated steam and strong fire powered heater heat it up. 		
	Grill	<p>With the strong heat from the upper heater, mark burn on the surface of food.</p> 	<ul style="list-style-type: none"> ● To mark burn evenly, flip the food in the middle of heating. ● After heating, take the food out immediately to avoid over burns. 	 Square tray  Gridiron
	Fermentation	<p>Heat with heaters and fans as controlling the temperatures.</p> <p>Steam fermentation...</p> <ul style="list-style-type: none"> ● Control the temperature well by using steam. 	<ul style="list-style-type: none"> ● Used for fermentation of bread dough. ● Bread does not become moist hence we recommend covering with cling film or wet cloths or to blow water mist over it. 	 Square tray  Deep tray  Gridiron

Preparation and Confirmation

Heating mechanism

Vessels you can use / Vessels you can't use

Notice For the way to use containers which are not mentioned, please contact their manufacturers or distributors.

Types of heating

Containers that can be used

MICROWAVE

STEAM MICROWAVE

Defrost

Notice sign (☞☞) will be displayed

○ Pottery • Porcelain



- However, the following containers cannot be used.
 - Containers with gold and silver (Sparking)
 - Containers with painting (painting will peel off)
- There are some containers that get heated with the radio waves. Take care and avoid burns.

○ Heat resistant glass



- If the container is cooled immediately after being heated, it may break.

○ Plastic containers that are heat resistant up to a minimum temperature of 140°C.

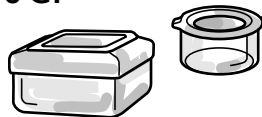

- However, the following items cannot be used.
 - Foods with high oil, sugar or salt content, ketchup, etc. (Becomes high temperature)
 - Sealed containers, Lids vulnerable to heat
 - Containers not marked with "Microwave oven use"
 - Containers or bags processed with metal such as aluminum on surfaces
- With "Auto Reheat" (Microwave heating using infrared sensor (page 20)), containers with lids cannot be used. Please take the lid off.

○ Wrapping with minimum resistance temperature of 140°C.



- However, it is unusable for very fatty food, because such food reach a high temperature.
- Polyethylene plastic wrap is unusable, because it will melt and may catch fire.

CONVECTION

Superheated steam

HYBRID

Grill

Steamed

Low Temp. Steam

Fermentation

Steam fermentation

○ Heat resistant glass



- However, if the container is cooled immediately after being heated, it may break.
- Cooking that become high temperature should be contained in container made of heat resistant glass that is strong against quick heating and quick cooling.

○ Metal containers, wire mesh and skewers of aluminum and enamel etc.

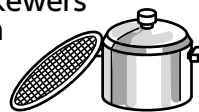

- However, containers with plastic handles are not to be used as such handles will melt.
- Can not be used for a part of the menu.

○ Aluminum Foil



- It may be used for cover square tray or under the food burning or when grilling.
- Can not be used for a part of the menu.

○ Silicon container



Cannot be used for Superheated steam, hybrid and grill.

- The temperature of the oven is set to (resistance temperature of the container - 30°C), do not place silicon containers at the rear end of the oven chamber. (Example of preset temperature: In case the heat resistance temperature of the container is 200°C → Preset temperature must be below 170°C)
- Will get heated to a higher temperature if kept near the air outlet of the hot air heater (inner rear end). The silicon container may deform if kept at the inner rear end.

Please do not mix up “Microwave” heating with “Convection” • “Grill” heating. If you are mistaken the food or container, it may catch fire or smoulder. Please confirm the heating type before heating. (on page 14, 15)

Containers that can not be used

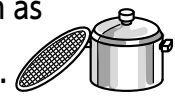
X Aluminum and metal containers such as metal rack unscrewed, etc. 

- Specially, in case of wire mesh and skewers there will be sparking.

X Aluminum Foil 

- However it may be used partially in the microwave (Sake can, defrost). Please use in accordance with explanations in this document. Sake can : page 27, three types of defrost: page 30

X Plastic containers and wraps that are heat resistant up to a maximum temperature of 140°C 

- They deform or break due to melting.
- Plastics such polyethylene, styrene, phenol, melamine and urea cannot be used.

X Plastic containers and wraps*1 

- They deform or break due to melting.

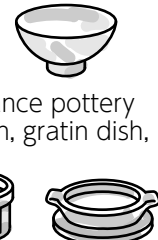
X Ceramic and Porcelain*1 

- However, heat resistance pottery such as a cooking pan, gratin dish, etc., is usable.

*1 : [Steamed] [Low Temp. Steam] [Fermentation] [Steam fermentation] are usable. Use heat resistant ones.

X Glass that are not heat Resistant 

- Cut glass or toughened glasses cannot be used.
- Crystal or hardened containers of different thickness or if distorted are unusable.

X Lacquerware 

- There is risk of the painting peeling off or getting cracked.

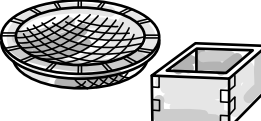
X Wood • Bamboo • Paper 

- May result in sparks or burning.
- However paper, oven sheet, cooking sheet and cake parchment paper can be used as per the instructed heat resistant temperature.

Accessories

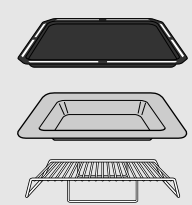
Square tray • Deep tray • Gridiron 

X Unusable

- Not used due to sparking.

Square tray • Deep tray • Gridiron 

O Usable

Heating empty oven/Deodorizing Heater

When operating the oven for the first time, take out all packaging materials such as the poly sheet inside the door and use "51 deodorize" to completely burn off the oil on the door. (Empty grilling) During the first time, smoke and smell may be released, this does not indicate a malfunction.

Remove any small pets or birds to different room that has ventilation to avoid suffocation due to smoke and open all windows.

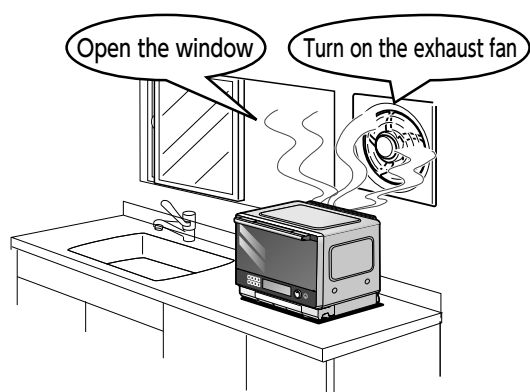

Empty grilling and deodorization must be done only after wiping off any dirt inside the oven. If it's done without wiping, dirt may burn and get stuck on.



■ "51 Deodorize" heats using a heater so the main body becomes hot. Please do not put close to objects which are not good with heat.

Warming the empty oven • Deodorize

- 1 Do not place anything inside the oven, Close the door.

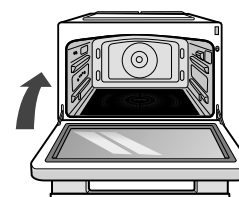

- 2 Select **51 Deodorize**



- If you turn left, you can select quicker.

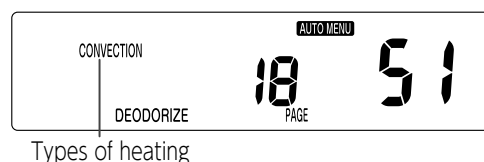

Types of heating

- 3 **Start** (Start Deodorizing)



- 30 minutes to deodorize

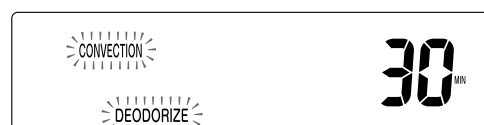

- 4 The buzzer will beep 3 times when finish deodorizing

- "High temperature" and "Cooling" will be displayed.

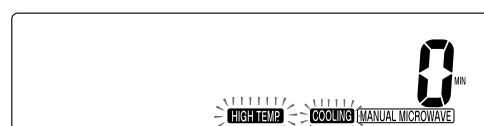

Open the door and wait for the temperature inside to cool down.

- Since the glass door and oven chamber is hot, be careful.
- Do not repeat the deodorize option.

• Burn off the dirt inside at high temperatures and deodorise. Not all types of odours can be removed.

“REHEAT” recommendations

What can be used to warm up?



● **Rice or food**

→Reheat [1 COOKED RICE], [2 Sides dish], [3 Two dishes]

Dial menu [23 Steam Reheat]

→ page 22 ~ 24

→ page 28 • 32

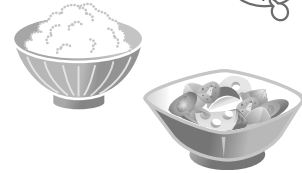

● **Milk**

→Touch menu With [16 Milk]

→ page 26 • 27



● **Sake**

→Dial menu [17 Sake]

→ page 26 • 27



● **Coffee • Water Beverages**

→Set time and output power in [Microwave]

→ page 34 ~ 35 • 46



● **Defrost meat and fish**

→Dial menu [18 Rapid Defrost, 19 Steam Defrost, 20 Sashimi Semi-Defrost]

→ page 28 • 30

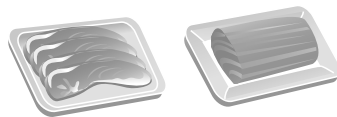

● **When you want to warm up deep fried foods, fried foods, french bread, curry bread, etc. crisply**

→Dial menu [24 Cripny Reheat]

→ page 28 • 32

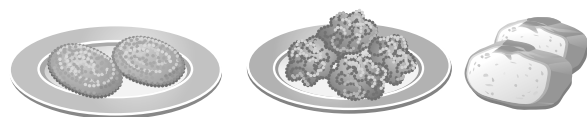

● **When you want to warm butter rolls or bread fluffily**

→Dial menu [25 Fluffy Bread]

→ page 28 • 33

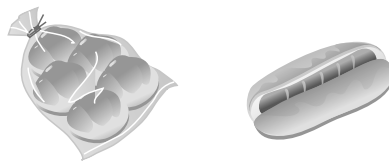

*Bread toast, please see on page 202

● **Chinese bun**

→Dial menu [26 Steamed Bun]

→ page 28 • 32



● **Frozen boiled vegetable**

→Set time and output power in [Microwave]

→ page 34 ~ 35 • 46



*Sprinkle water for heating corn and mixed vegetable. Use microwave safe container for heating.

● **Commercially processed frozen food**

→Set time and output power in [Microwave]

→ page 34 ~ 35 • 46



*Refer to the instructions on the packet for heating and monitor the food while heating.

When heating with microwave

Microwave heating using the infrared sensor (“Auto Reheat”)

- Reheat (Cooked rice • Dish • 2 dishes) ● Beverage ● 3 Defrost ● Boiled vegetables
- Steam reheat ● Desired temperature

※What is infrared sensor?

It is a sensor to measure infrared volume radiating from food in order to detect temperature at food surface. Heating while detecting temperature at food surface, enable us to cook at defined temperature without being affected by starting temperature, weight of food containers, etc.

To provide proper detection of food temperature with an infrared sensor, Please refer page 20~21.

Please follow the instructions

● Proper use of wraps

- When food wrap is used, some portion of it is unused. Read the instruction in the menu carefully.
- Ensure the wrap does not overlap and is covered securely in the bottom.
- Incorrect uses will cause the dish may not be cooked well. The food may burn due to smoke or fire.



● Do not use cover

- If ceramic, glass or plastic products are covered with a lid, the infra-red sensor will not be able to detect the temperature of the food accurately and cannot heat correctly.
- Food boxes in market are the same. Please take cover and aluminum foil out.

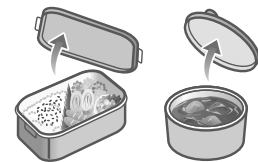

● If the oven is continuous used, ensure that it cools down.

- If the oven is hot, the infrared sensor may not be able to detect the temperature correctly. If the “HIGH TEMP.” is displayed in the control panel, wait until the display disappears.

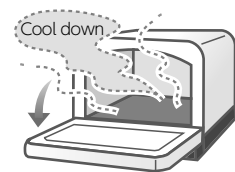

● Use proper containers according to the quantities of food.

● Use the containers with a low and wide edge.



● Clean the cavity and wipe vapor before next use.

- If not proceed the cleaning, the infrared sensor may not work properly.



! WARNING

PROHIBIT

Do not heat food less than 100g※ automatically

Since the food temperature is not properly detected, food gets overheated and might cause fire.

- Please heat manually while checking the food inside carefully.

※ Automatic cooking "Rapid defrost" or "Steam Defrost" is for less than 50 g



PROHIBIT

Do not use heating cook with infrared sensor for containers with lids

With lid, the food temperature cannot be properly detected, food gets overheated and might cause fire or the container might break.

- Please remove the lid before heating.

Proper positioning of food

- You cannot use square tray, deep tray or gridiron.

➔ If you use square tray, deep tray or gridiron, sparks fly, potentially causing a breakdown.



Square tray

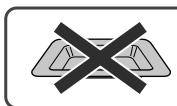

Deep tray

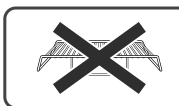

Gridiron

- Please use a mug based on the following measurements as a guide.
- Amount in one cup: Please fill up to 8/10 of the container.

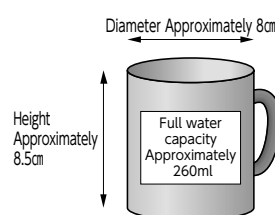

- Place food in the middle of oven
In case of multiple food items, place at the center of the oven chamber close together.

- If you place it somewhere far from the center, it may be excessively heated or not warmed. So please always place at the middle.
- For a small item of food, though you place it in the middle, it may not be detected and causes smoke or fire. In case of small quantity of food, heat the food manually with "MICROWAVE" monitoring the process.
- For beverage, if you place it at the edge, it may overheat and boil. When take them out from the oven, they might blow and cause burn injury.

Place food correctly!

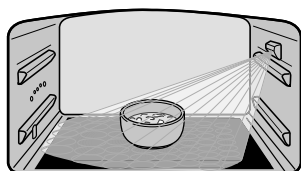
**Infrared sensor detection image and How to place object in the oven**

Reheat, Desired Temp.

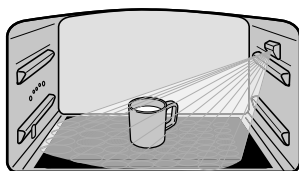

1 cup (milk)

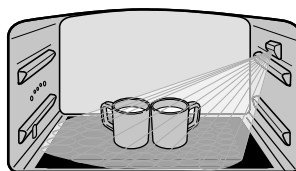

2 cups (milk)

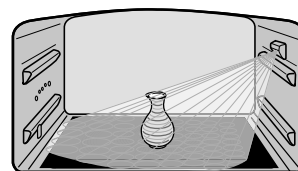

mug (sake)

For a small item of food, it may not be detected by infrared sensor and cannot be cooked well.

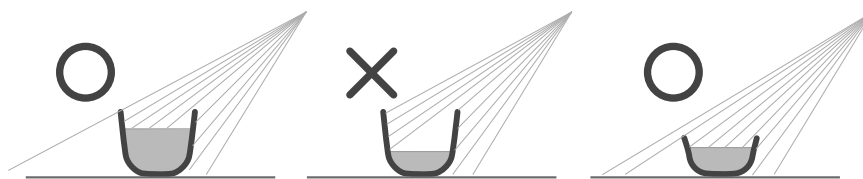

Using infrared sensor

Warming up rice and side dish



Press once then 1 Cooked rice

Press twice then 2 Sides dish

Press three then 3 Two dishes

Just place food and press "REHEAT" key then the food will be easily reheated.

"NO WRAP" "METAL" signs will light. (Although "NO WRAP" sign lights, there are some kinds of food better to be wrapped. Please refer to Tips for using "Reheat" skillfully on page 23~24 for details)

WARNING



Forbidden

Do not heat food less than 100g automatically.

Since the food temperature is not properly detected, food gets overheated and might cause fire.

- Please heat manually while checking the food inside carefully



Forbidden

Beverage should not be reheated with "REHEAT" button.

It might be too hot and suddenly boiled. It might cause burn injury when taken out.

- Please warm milk or sake using the "BEVERAGE" button and for coffee and water, warm using the manual setting using times on page 46 as a guide.

Basic operation (Ex : Reheat rice)

1 Place food (Rice) at the center of the oven chamber

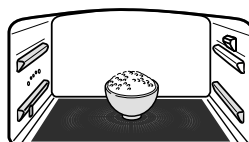

Place at the center of the oven chamber without wrapping

Accessories cannot be used

※If you place it far from the center, the infrared sensor may not work well and may overheat or not warm up properly.

2 Start (Start reheating)



- As you press each time, The state will be switched to
→ 1 Cooked rice → 2 Sides dish → 3 Two dishes (within 5 seconds)
- Press within 1 minute after closing the door.
→ Will not work if you wait for more than 1 minute after opening or closing the door ("DOOR" will be displayed) press "REHEAT" key after opening and closing the door once again.

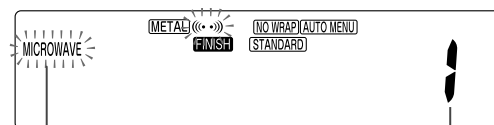

Type of heating

- Switches to the remaining time display from the middle.
- Remaining time changes during cooking depending on the state of the food. It may become shorter.

3 The buzzer will beep 3 times when finish.

- If you forgot to take the food out, the buzzer will beep 5 times in an interval of one minute. The beep will stop on press "CANCEL" and open the door.
- Once cooking is completed will flash, and the fan may operate to **COOLING** the interior of the oven.

Please to not unplug the power plug while the cooling fan is operating.

Cooking can be continued when the fan is operating. (However, there are some automatic menus that cannot be used.)

The container is hot, take care while removing the container



Heat Adjustment

→ Can be increased or decreased by turning the dial to "INCREASE" or "DECREASE" within 15 seconds of starting.

- Turn right "Increase" and left "Decrease" for selection. Increase and Decrease can be select 1,2,3 levels both.

Decrease Increase



For further heating, once cooking is complete. (EXTENSION)

→ This is done by rotating the dial to set the time within 1 minute after the completion of cooking and the process has to be monitored.

If the door is opened during the cooking process.

→ Press "CANCEL" and heat manually with "MICROWAVE" while monitoring the process (See pages 34 and 35)

When you want to warm automatically without extension after completion

→ When extension is displayed, if warming using "1 Cooked rice", "2 Sides dish" or "3 Two dishes", use the "CANCEL" button Please press the "REHEAT" button after pressing.

Notice

- Please use for warming rice and side dishes. With other foods there is risk of smouldering or catching fire due to overheating. Foods with little moisture (dried foods, monkey nuts, etc.), dried foods, dried parsley, etc. should be heated whilst monitoring at manual microwave 200W.







Please read

Things to follow on Page 20 ~ 21

Microwave (Infrared sensor)

Accessories cannot be used

Food	Quantity	Wrap	Recommended course	Adjusting finishing	Tips		
Rice	Rice  (150g a cup)	No	1 Cooked rice Press "REHEAT" button once	Standard	<ul style="list-style-type: none"> Loosen the lumps and splash water on harder things such as frozen rice. With it still wrapped in wrap, place the side where the wrap overlap on the bottom and place on a flat plate.   If it is insufficiently heated, additionally heat after turning it upside down and monitoring, using the manual "MICROWAVE" mode. 		
	Frozen rice	100~300g (150g each)				Do	
Boiled food	Meat stewed with potatoes, etc.	No	2 Sides dish Press the "REHEAT" button twice	Standard	<ul style="list-style-type: none"> If there is a lot of sauce, it becomes harder to warm so try and limit the amount of sauce. Place in a shallow container and because it will splatter, put the wrap right on the food.  		
	Boiled fish	100~400g				Do	
Steamed food	Dim sum, etc.	No		Standard	<ul style="list-style-type: none"> Spray water mist when it's dry. Spray water mist when it's dry. Put wrap right against the food. 		
	Frozen Dumplings	100~300g (15~20g each)				Do	
Soups	Miso soup, etc.	1~2 cups (150g a cup)		Standard	<ul style="list-style-type: none"> Stir miso soup well before and after warming. Do not use mugs for miso soup or soups. 		
	Curries and stews, etc.	100~400g				Increase 3	<ul style="list-style-type: none"> Put into a shallow bowl and drop in so that it's fully touching the food and wrap. (If there is a gap, the infrared sensor may not work properly and food may smoulder or catch fire) Once heated, mix the whole thing. If there is insufficient heating, warm up whilst monitoring the situation under manual "MICROWAVE" mode.
	Frozen curries / stews	100~300g					
Grill	Grilled fish	100~300g		Standard	<ul style="list-style-type: none"> There are cases when fish isn't heated properly due to the type, shape and size of it. Sauce will splatter so pour on after heating. If it is already covered in sauce, cover with wrap and warm whilst monitoring it under manual "MICROWAVE". 		
	Hamburg steak, etc.	100~400g				No	
Fried foods	Stir-fried	100~400g		Standard	-		
	Gloopy foods such as chop suey.	100~400g	Increase 3			<ul style="list-style-type: none"> Side dishes which are gloopy can splatter hence cover with wrap so that it is attached to the food. Mix the whole thing once warm. Do not warm quail eggs. If it contains prawns or squid, they can spit hence warm up with wrap on whilst watching the status under the manual "MICROWAVE" mode. 	

◆◆ How to preserve rice with freezing method ◆◆

- Rice must be spread thinly (2~3 cm) with proper amount for each time (150g). If you make rice round off or warm them all together in big volume, it may be difficult to be warmed up well with heat reaching inside. Food is put in preservation containers or preservation bags, it may not be warmed up well.



- Let's prepare tasty hot rice as well as possible. If we preserve food by using plastic wrap to cover while it is still fragrant with heat, steam will be protected and prevented from escaping, so it will be hardly dry though being reheated.

■ When heating more than one dish...

- When the food items are same (type, temperature and quantity) heat with either "1 Cooked rice" or "2 sides dish".
- When the food items are different, or there is a difference in temperature (frozen and refrigerated, frozen and normal temperature), heat with "3 Two dishes".

■ When heating commercially processed frozen food...

- It may not be heated well with auto "REHEAT". Refer to the instructions on the packet for Heating with manual "Microwave" and monitor the food while heating.



Please read

Things to follow on Page 20 ~ 21

Microwave (Infrared sensor)

Accessories cannot be used

3 Two dishes... Different types of food, items with differences in temperatures are heated at the same time for eating and this takes more time compared to "1 Cooked rice"

〈 Placed Position 〉 Place close together at the center. More time compared to "1 Cooked rice" try to ensure that food is not placed at the ends.

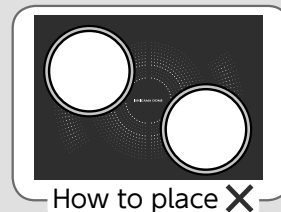
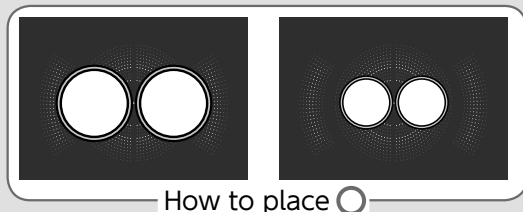

- The quantity that can be heated at one time ... Refrigerated, normal temperature for single item 100 to 250g, Frozen, for single item 100 to 150g
- There may be cases where the food may not be heated properly depending on the combination of the type and quantity of food.
- Protect the heated quantity
 - rice and food ... the food must be slightly less in quantity compared to rice. (half quantity to same quantity of the rice)

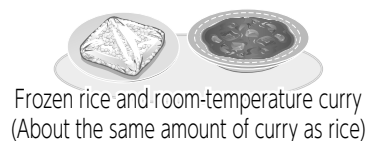
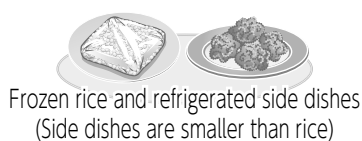
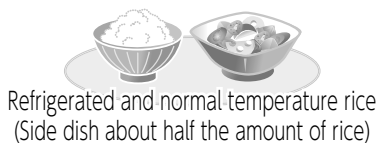

- Frozen rice and refrigerated food

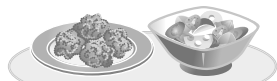

slightly less compared to the quantity of rice

● Food that does not get heated properly with two dishes

- Frozen curry, soup, grilled fish that can burst easily, commercially available cooked frozen food and dishes with dipping or sauces
→ "2 Sides dish" and heat the items one by one. (See page 23)
- Bread or Beverages
→ Heat after reading the "Reheat" Recommendation Guide. (See page 19)
- When the two dishes includes frozen dish
→ if heating is insufficient, heat manually with "MICROWAVE" while monitoring the progress.

● Heat without wrap or lid

- Rice... For refrigerated rice etc. that is hard, loosen the lumps and sprinkle water.
- Boiled food...Broth is removed.
- Steamed food...Mist is released when dried.

● Frozen food must be wrapped, placed in a container and heated

- Frozen food...Must be placed on the tray with the folded side of the wrapping facing downwards.
- When you freeze food, fit the wrap tight onto the food.

● Thick foods (such as curry and chop suey) must be heated with the wrapping (to prevent the juice from flying)

- Place the food in a deep container and wrap from the top to the bottom so that the food is completely covered.
(If there are any gaps, infra-red sensor will not work effectively, and there is a risk of smoke or burning of the food) mix the food after heating is completed.

Sink the wrap to stick on the food.



(Deep container)

Auto cooking



Cooking

Non-fry/Hybrid button, Deep tray menu button, Quick/Easy button - explanation of basic operations of automatic menu chosen by these are provided. Please refer to the cookbook for detailed procedures.

- Hybrid : Heater heating · Use superheated steam and heater to cook food.

Basic operations (example: 4 Chicken Karaage)

1 Use the touch menu buttons to select the **Menu number** example: 4 Chicken Karaage



- 4 Chicken Karaage → 5 Fried → 6 Easy Fried → 7 Teriyaki Chicken → 8 Hamburg Steak → 9 Salted Salmon
- 10 Dry Noodles Menu → 11 Multi-Recipe Cooking → 12 Speed Deep Tray
- 13 Speed Menu(3 min→5 min→7 min) → 14 Appetizers 1 Minute → 15-1 Fast Low Temp. Cooking(Steamed Egg) → 15-3 Fast Low Temp. Cooking(Mild Pickles) → 15-2 Fast Low Temp. Cooking(Pickles) ←

• Press the menu which needs preheating (6 · 7 · 8 · 10 · 11 · 12)

- To start preheating → The buzzer will beep 5 times when finish preheating (remaining time is displayed one minute before the end of preheating)
- After preheating, put the food in and press the "START" button to start heating.
- Preheat can be retained for approx. 20 minutes. (10 minutes for menu 10)
- If idle for the moment, the buzzer sounds 3 times and the setting will be canceled.

2 Place food at the specified position Basic operations

※Water tank preparation is needed for Menu 7, 8 and 9 (Refer to page 13)

3 Start (Start cooking)



4 The buzzer will beep 3 times when finish.

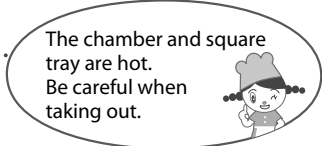

- LCD displays "HIGH TEMP."
- If you forgot to take the food out, the buzzer will beep 5 times in an interval of one minute. The beep will stop on press "CANCEL" and open the door.
- Since the square tray etc. will be hot, take care while removing the container. In addition, be careful as there will be steam coming out of the outlet port after steam cooking.
- Please remove water and maintain the pipe when using menu item 7, 8 and 9 (Page 51)

Heat Adjustment

- Can be increased or decreased by turning the dial to "INCREASE" or "DECREASE" within 15 seconds of starting.
- Turn right "Increase" and left "Decrease" for selection. Increase and Decrease can be select 1, 2, 3 levels both.

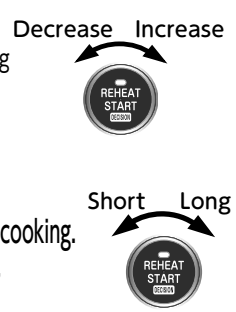

To increase or decrease the time during the cooking.

- when the remaining time is displayed, rotate the knob to increase or decrease the time by 1 minute.
- Short / easy menu cannot be increased or reduced.

When the display are is flashing "collect water"

→ Please check the "WATER" display on page 57

For further heating, once cooking is complete. (EXTENSION)

→ This is done by rotating the dial to set the time within 1 minute after the completion of cooking and the process has to be monitored.



Notice

Follow the information provided in the instruction manual and the cookbook for ingredients, quantity and cooking methods.

- The dishes (quantity) excluding those described in the cookbook may not get prepared properly with dial menu (Heat with manual cooking while monitoring the progress.)
- The final result may vary depending on the room temperature, initial temperature, Chamber temperature and power supply voltage etc.

Using infrared sensor

Warming up milk or sake

WARNING



Do not set temperature too high when warm up beverage.
 Since liquid which is beverage may boil right away and cause burn injury when being taken out.
 • Before and after reheating beverage, it should be stirred thoroughly by a spoon.

Basic operations (Ex : Reheat milk)

1 Place food at the **center of the oven chamber**

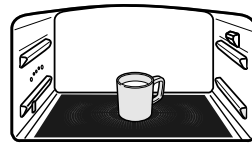



Place at the center of the chamber

Microwave (Infrared sensor)

Accessories cannot be used

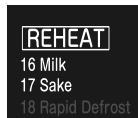
2 Select **16 Milk (number of cups)** (It can be selected by turning the dial)



 16-1 cup → 16-2 cups → 16-3 cups → 16-4 cups → 17 Sake

3 **Start** (Start heating)



Display example : Milk

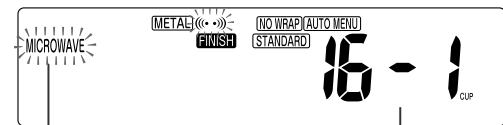

Types of heating

Switches to the remaining time display from the middle.

4 The buzzer will beep 3 times when finish.

- If you forgot to take the food out, the buzzer will beep 5 times in an interval of one minute. The beep will stop on press "CANCEL" and open the door.
- Once cooking is completed will flash, and the fan may operate to **COOLING** the interior of the oven.

Please to not unplug the power plug while the cooling fan is operating.
 Cooking can be continued when the fan is operating.
 (However, there are some automatic menus that cannot be used.)

The container is hot, take care while removing the container



■ Heat Adjustment

→ Can be increased or decreased by turning the dial to "INCREASE" or "DECREASE" within 15 seconds of starting.

- Turn right "INCREASE" and left "DECREASE" for selection. Increase and Decrease can be select 1, 2, 3 levels both.



■ If the door is opened during the cooking process.

→ Press "CANCEL" and heat manually with "MICROWAVE" while monitoring the process (See pages 34 and 35)

■ For further heating, once cooking is complete. (EXTENSION)

→ This is done by rotating the dial to set the time within 1 minute after the completion of cooking and the process has to be monitored.



Things to follow on Page 20 ~ 21

Microwave (Infrared sensor)

Accessories cannot be used

16 Milk

Reheat milk in a cup.

- Setting the number of cups ... It changes as 16-1 cup → 16-2 cups → 16-3 cups → 16-4 cups ← 17 Sake
- Quantity you can reheat at once ... 16-1 : 1 cup, 16-2 : 2 cups, 16-3 : 3 cups, 16-4 : 4 cups (Please confirm when you select the number of cups as it will cause over heating)
- Place the cup at the center of the chamber.
If the cup is not place at the center, the infrared radiation may not be able to sense temperature accurately and the milk may start boiling.

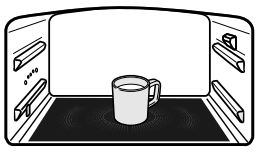

1 cup

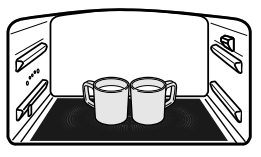

2 cups

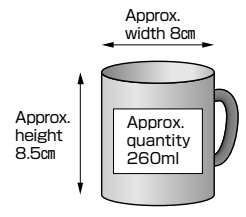

- Follow the instructions regarding cup size and the quantity of milk used.
If the cup size or the quantity of milk differs, the infrared sensor may not work properly.
 - Use a short cup with wide mouth.
The cup size should correspond to that illustrated in the figure.
 - Use 1 cup or glass ... 200ml as standard amount. (If being less than this, it may cause eruptive boiling)

The milk may start boiling suddenly after taken out causing burn injuries.

- Stir the milk with spoon before reheating.
- After reheating, wait for a while before taking the milk out.



17 Sake

Heat sake in the bottle

- Quantity you can reheat at once ... 1 to 4 bottles
- Place the bottle at the center.

If not placed in the center, infrared sensor may not work properly and the liquid may start boiling.

- Follow the instructions regarding cup size and the quantity of sake used.

- The bottle should be short and stout. (Change in size, shape or quantity of bottle will result in a different final product).
- Use 1 bottle...160ml (equal to volume of 80% of Sake bottle) as standard amount. (If the quantity is too little, the liquid may be start boiling.)
- In order to reduce uneven heating, thin portions have to be covered with an aluminum foil.
※If aluminum foil touches the walls, bottom or door, it may spark and break the glass. So be careful not to let it touch.

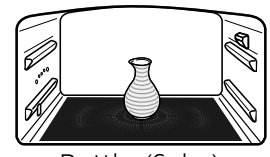

Bottle (Sake)

■ How to place according to the number (number of bottles)
→Place close together at the center.

1 cup (bottle)	2 cups (bottles)	3 cups (bottles)	4 cups (bottles)

■ If container types, size or volume differ or drinks such as coffee, water or sake in a cup
→Use “MICROWAVE” set the time modestly and monitor the heating (Refer page 46)

Auto cooking

Cooking with the dial menu



The basic operations of the dial menu 4~48 have been explained.
See the tips for effective use given in pages 30 to 33. (MENU 18~26, 31~33)
Please refer to the cookbook for detailed procedure for each menu.

Basic operations (Ex : 39 Cookies) The operations may vary depending on the menu.

1 Place the food into the chamber.

※Prepare water supply for the menus that are marked with (Refer page 13)

On page 30, 32~33 

Refer to cookbook for other menus.

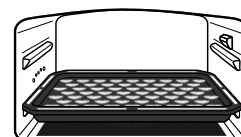

Place at the specified position.

2 Select Menu number



34 French Bread	38 Bagel	42 Chiffon Cake
35 Butter Roll	39 Cookies	43 Fresh Chocolate
36 Tomato&Cheese Pizza	40 Choux Cream	44 Baked Sweet Potato
37 Plain Bread	41 Sponge Cake	45 Cream Caramel

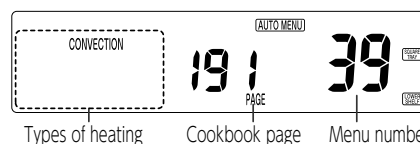

Types of heating

Cookbook page

Menu number

- Turn the dial and choose from the described menus (4 - 48).
- The menu number is displayed in the display area.

3 Start (Start cooking)

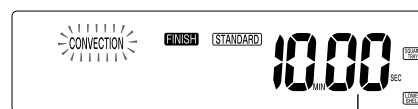

The remaining time is displayed from part of the way through.

- With some of the menu, the buzzer sounds 5 times during cooking hence please open the door and after following instruction in the cookbook, please close the door and press the "START" key. (See page 33 "about notifications during cooking")
- With steam warming, after pressing the "START" key, steam comes out after about a minute.

4 The buzzer will beep 3 times when finish.

- LCD displays "HIGH TEMP."
- If you forgot to take the food out, the buzzer will beep 5 times in an interval of one minute. The beep will stop on press "CANCEL" and open the door.
- Since the square tray etc. will be hot, take care while removing the container.
In addition, be careful as there will be steam coming out of the outlet port after steam cooking.
- Please remove water from the pipe and maintain for menu items using steam. (Page 51)

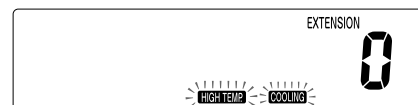

The container is hot, take care while removing the container



■ Heat Adjustment

- Can be increased or decreased by turning the dial to "INCREASE" or "DECREASE" within 15 seconds of starting.
- Turn right "Increase" and left "Decrease" for selection. Increase and Decrease can be select 1, 2, 3 levels both.



■ To increase or decrease the time during the cooking

- When the remaining time is displayed, rotate the knob to increase or decrease the time by 1 minute. (There are also menus which cannot be increased or decreased)

DECREASE INCREASE



■ For further heating, once cooking is complete. (EXTENSION)

- This is done by rotating the dial to set the time within 1 minute after the completion of cooking and the process has to be monitored.

■ When water in the water collecting cassette is gone during steam cooking

- There will be a beep and the "WATER" display will start blinking. Add water in the water tank.
- "WATER" display will disappear once water is added. (Water can be added to the water tank, even during cooking operation.)

For menu that require preheat (Ex. : 31 Bread)

1 Select Menu number



30 Steamed Egg	34 French Bread	38 Bagel
31 Easy Bread	35 Butter Roll	39 Cookies
32 Easy French Bread	36 Tomato&Cheese Pizza	40 Choux Cream
33 Easy Pizza	37 Plain Bread	41 Sponge Cake

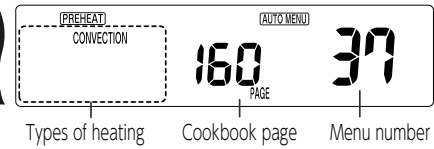

- Turn the dial and choose from the described menus (4 - 48).
- The menu number is displayed in the display area.

※Prepare water supply for the menus that are marked with (Refer page 13)

2 Start (Start preheating)



Display shows the remaining time 1 min. before preheat finish.

- Preheat can be retained for approx.20 minutes. (Around 10 minutes for menu items 10 and 36)
If nothing is done during that time, the buzzer goes off three times and menu selection is canceled.
- If you attach the square dish to preheat, the square dish will get hot. Be careful when you take it out or put food on it.

The buzzer will beep 5 times when finish preheating

3 Put the food inside and **start** (Start cooking)



Displays the remaining time.

- If you press the "START" button after putting the food in, heating starts.
- ※After the end of preheating, even if you press the "START" button, it does not operate if the door is not opened and closed

4 The buzzer will beep 3 times when finish.

- LCD displays "HIGH TEMP."
- If you forgot to take the food out, the buzzer will beep 5 times in an interval of one minute. The beep will stop on press "CANCEL" and open the door.
- Since the square tray etc. will be hot, take care while removing the container.
In addition, be careful as there will be steam coming out of the outlet port after steam cooking.
- Please remove water from the pipe and maintain for menu items using steam. (Page 51)



Tips

Since the square tray will be hot after cooking, Be careful!

- Be careful when open the door to take the food out as hot steam escapes from the oven.
- Please read Safety Precaution "Heater heating/Steam heating" on page 7.
- Please use containers that suit the type of heating. "Containers that can be used/cannot be used" (Pages 16, 17)

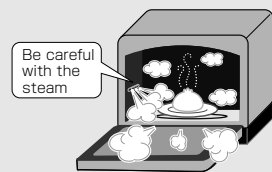

Notice

Please comply with the materials, volumes and cooking methods described in the instruction manual and the cookbook.

- Cooking (amounts) other than those listed in the cookbook may not finish well with automatic cooking. (Please heat whilst monitoring under manual cooking)
- The finish or the heating time may change depending on room temperature, initial temperature, inside temperature and power voltage, etc.

Microwave (Infrared sensor)

+

Steam*

*Steam will be added only on "19 Steam Defrost"



Please read

Things to follow on Page 20 ~ 21

Accessories cannot be used

Defrosts the meat and fish that was kept in the freezer.
Defrost at once in the frozen state after removing from the freezer.
(If the surface is slightly melted, it ends without being fully defrosted and is not defrosted well)



Shallower Styrofoam tray

18 Rapid Defrost

Microwave heating defrosts in a short time to the extent that preparations can be made.
(Meat or sliced meat with much fat will specially be harder and may cause not to be defrosted well.)

19 Steam Defrost : Refer water tank preparation (Page 13)

It takes time but defrost until you can loosen minced meat or peel sliced meat by microwave heating and steam heating.

20 Sashimi Semi-Defrost

It finishes it in a state where it's easy for a knife to go in and for the inside to be slightly frozen.
For cutting meat or sashimi thin.

- Amount which can be defrosted at once ... 50~600g
(sashimi, semi-defrost 100~600g)

- Defrost in the polystyrene tray without wrap or a lid

- Infrared sensor may not work with deep polystyrene trays so please either transfer to shallower trays or place on kitchen paper on a flat plate then defrost.

- Arrange food to be defrosted in proper size. (Food up to a thickness of 3cm will be defrosted properly)

- If 2 or more items are to be defrosted at the same time, items of the same type and size have to be collected.

- Cool the oven chamber before starting to defrost.

- If it's hot inside, the infrared sensor doesn't work well. When "C21" "HIGH TEMP." are displayed on the display area, press "CANCEL" button and wait until the temperature inside has reduced by opening the door.

- Use Aluminum foil to prevent discoloration or cooking.

- It is recommended to wrap the surrounding when quantity is big.
- If shape is uneven like fish, wrap on thin parts to prevent overheated.
※ Please wrap the aluminium foil properly. If the aluminium foil touches the walls inside, base or the door, sparks may appear or the glass in the door may crack so please take care that they don't touch.

- According to the shapes or types of food to defrost, it may boil only partially or hard parts may remain.

- Especially, fat or sliced hot pot meat may not defrosted well.

- If the amount of food is less than the amount which can be defrosted, if the surface is slightly melted or there is insufficient defrosting.

→Use "MICROWAVE 200W" to heat as monitoring the food closely (Page 46).

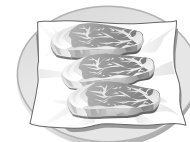

Freeze well, defrost well

- Prepare fresh food to freeze.
- Please ensure that the food is one portion, thin (less than 3cm), even thickness and flat. Please make the size more than height 6cm × width 10cm. If it's too small, overlapping or in a lump, it cannot be defrosted well.



Things to follow on Page 20 ~ 21

Microwave (Infrared sensor)

Accessories cannot be used

Heat vegetables (Leaves/Roots) as if they are really boiled.

21 Boil Vegetables (Leaves) : Spinach/Broccoli/Cabbage

- Amount to be heated at once ... 100~300g. (Only weight of food)
- Preparations ... Wash the vegetable and wrap it securely
Must be placed on the tray with the folded side of the wrapping facing downwards.
 - Overlap leaves and stems interchangeably, cross cut on thick stems, then wrap them firmly.
 - Wrap as wide as possible, not to let them protrude from the flat plate.



Place on the tray

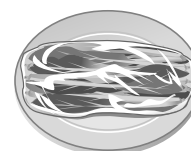

22 Boil Vegetables (Roots) : Potato/Taro/squash etc.

- Amount to be heated at once ... 100~600g. (By weight only)
- Preparation ... Wash the vegetable and place it on a flat plate.
Wrap the vegetable along with the plate securely and then cook. Ensure that the wrap is in contact with the food.
 - When boiled whole
Wrap the vegetable securely along with the plate and cook. After cooking, remove from the oven chamber. Leave for a while (about 5 minutes), without removing plastic wrap.
(Food will dry easily, please leave them without unwrapping plastic wrap)
 - If more than one vegetable is used, arrange it properly for uniform heating.
 - In case a round, large potato is used, adjust the final temperature (increase) for desired result.
 - When the vegetable is cut and boiled
Peel and cut, arrange it on flat plate and sprinkle some water wrap the vegetable securely along with the plate and cook.

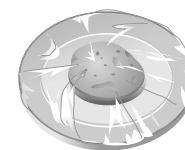

Tips

- Ensure that leafy and root vegetables are placed on flat plate and cooked.
- Wrap leafy vegetables separately and not along with the plate.
- Wrap root vegetables with the plate.
- Do not use many layers to wrap or roll the food.
- Do not use any other wrapping material other than cling wrap.
- ※If proper usage is not followed, food may burn or catch fire.
Spark may also occur and the bottom chamber may break causing damages.

■ If the size of vegetable differs or high moisture is required to cook the vegetable

- Sprinkle more water and place it in a container for microwave. Use microwave at 600W to heat and adjust the time and cook. (Page 46)
- If finely cut carrots and mixed vegetables are cooked by selecting "Root", spark may occur causing the food to burn. It may also make the food dry.



■ When the quantity of food used is little or less than 100g.

- Use the "MICROWAVE 600W" to heat and monitor the food closely (Page 46)
If Auto menu is used, the food may catch fire or smoke.

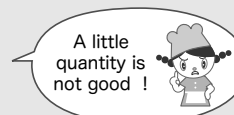

■ When under-heated

- Flip food upside down and front back, and heat with Extension heating or "Microwave 600W" as monitoring the process.

23 Steam Reheat

Microwave (Infrared sensor)

+

Steam

Please read



Things to follow on Page 20 ~ 21

Accessories cannot be used

Reheat Shumai or cooked rice with moisture using steam. It takes more time than “1 Rice” or “2 Dish”

- Quantity you can reheat at once ... Refrigerated/room temperature rice : 100~600g;
Refrigerated/room temperature dim sum and other side dishes : 100~300g
Frozen rice or dim sum : 100~200g
- Heating Method ... Warm in the centre without wrap or a lid.
- Thick foods agents are not heated
 - Since thick foods such as curry and chop suey are difficult to heat, heat with “2 Dish” (INCREASE 3).

* Chinese steamed buns, meat buns and buns with bean paste may not be heated properly depending on the size. Heat with “26 Steamed Bun”, or heat with “STEAM MICROWAVE” or “MICROWAVE” monitoring the progress.

24 Crispy Reheat (The standard heating time is approximately 10 minutes)

Heater

+

Steam

Crisply warms up room temperature deep fried foods, grilled foods, French bread and curry bread.

- Quantity you can reheat at once ... 100~200g (croquette : around 1~2, tempura prawns : around 1~4, curry bread : around 1~2, French bread : around 4 slices, katsu sandwich : around 2 pieces)
- Heating Method ... Remove food packaging or container, place gridiron on a square plate, then place on the bottom shelf with food directly on it then warm it.
 - Adjust the finish by rotating the dial based on the preferred heat, type and number of pieces.
 - Please warm ready-made refrigerated foods using Finish “INCREASE”.
 - It cannot be used for shop bought ready-made frozen foods. Please warm whilst monitoring the situation under manual “MICROWAVE” in accordance with package instruction.
- Warm after removing food packaging or containers.
 - Wrap and plastic covers that are heat sensitive must be removed before heating. Do not place the food in a container. Place the food directly on the grill and heat.

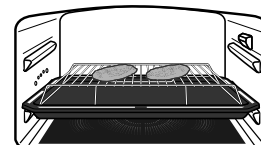

Place square plates and gridirons on the lower shelf

26 Steamed Bun (The standard heating time is approximately 20 minutes)

Steam

Warm shop-bought Chinese buns fluffily.

- Quantity you can reheat at once ... 1~4 (around 90g each)
- Heating Method ... Place a gridiron on the corner plate and place the chinese bun with packaging removed and warm on the bottom shelf.
 - Please warm frozen Chinese buns using Finish “INCREASE”.
 - Please control the finish by turning the dial depending on your Desired Temp., initial state (refrigerated/room temperature), number of items.
- Warm after removing food packaging or containers.
 - Please remove packaging such as wrap or plastic.

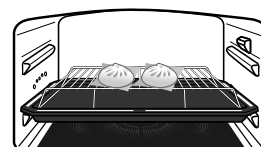

Place square plates and gridirons on the lower shelf

25 Fluffy Bread

Heater + Microwave

This warms shop bought bread (butter rolls and savoury breads) fluffily.

- Amount that can be warmed and setting (How to adjust finish See page 28)

Adjusting finishing	Standard	Increase 1	Increase 2	Increase 3
Standard time for heating	Approximately 3 minute 30 seconds		Approximately 4 minutes	
(Room temperature / refrigerated) Butter roll	4 pieces		—	
(Room temperature / refrigerated) Savoury breads	1 piece		—	
(Frozen) Butter roll	—		1 piece	2 pieces

Butter roll : around 30g each, savoury bread : around 100g each

For refrigerated or room temperature bread, please adjust between Decrease 3 - Increase 1 setting depending on your Desired Temp., initial temperature of the bread and number of items.

Please use setting Increase 2 or Increase 3 for frozen butter rolls.

- If you warm room temperature or refrigerated bread with Increase 2 or 3, it'll get too hot.
- Warming will be insufficient for frozen butter rolls with anything other than Increase 2 or 3.

- Heating Method ... Take off the packaging and container, lay cooking sheet on the base inside, then warm bread by lining them up in the centre on top of it, directly.

- "Extension" is oven heating mode.
When using additional heating with the microwave, set it for 10 seconds each at 600W under manual whilst monitoring the situation.
- Please cook toast using "46 Toast" "47 Toast (Frozen)" "48 Steam Toast".

- Heat after removing the wrap as well as the container.

- Remove the aluminum foil.
Heating is done combining both microwave and heater.
Aluminum foil etc. can cause sparking and hence must never be used.
- Remove packaging weak to heat such as wrap or vinyl and place directly on a cooking sheet without transferring to containers.

Accessories cannot be used

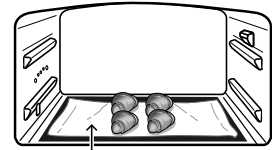

Cooking sheet
Place food in the centre

31, 32, 33 Easy Bread series

Microwave → Heater*

Use microwave oven to shorten time for powder leavening. It takes around 1 hour from dough making to baking.

*32 Use steam too for easy French bread

- If you start it after choosing the menu, it will first proof then bake.

- Time displayed is the time for each process.
- The end of the process is notified when the buzzer sounds 5 times.
It will go onto the next process so please do not press the "CANCEL" button and continue with the process in accordance with the cookbook.
- When you want to choose your preferred finish, turn the dial within 15 seconds of the start to adjust the finish.
The proofing time is automatically adjusted only for (Increase 3) and (Decrease 3).

- Beware of the accessories

- Microwave heating process cannot be used with square plate, gridiron, metallic containers or containers which are not heat resistance so please be aware of this.

- How to make it and cautions regarding accessories can be found in pages 142 - 147 of the cookbook.

◆ Notification during cooking (buzzer sounds 5 times)

- There are some menus with which notification buzzer sounds for operations such as turning over part of the way through cooking.
- If you press start without opening and closing the door, it won't operate. ("Door open/close" is displayed and the buzzer sounds)
- If you do not open the door, the buzzer sounds every minute up to 5 times.

Manual cooking

Heating / Stew with microwave



Example : Heating rice (at 600W for 1 minute)

(Guide to time setting : page 46)

1 Place food (Rice) at the center of the oven chamber

- Put in a heat resistant container which can be used in the microwave suitable for the amount of food and place directly in the centre.

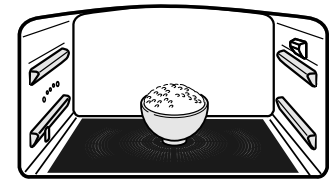

Place at the center of the chamber

2 Select OUTPUT



On pressing, it is the cycle change to

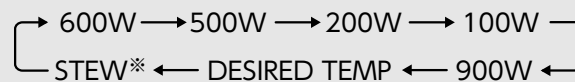

※If stew is selected, initial setting of 600W will be displayed.

3 Adjust the time.



- Maximum Time
Microwave 900W : 5minutes
Microwave 600W, 500W : 20minutes
Microwave 200W, 100W : 90minutes

For Stew, after adjusting time for 600W, Press the dial to decide, then adjust time for 200W.



Output Cooking duration

■ Setting unit of cooking time

	0	5min		
900W	10sec.interval			
600W	0	5min	10min	20min
500W	10sec.interval	30sec.interval	1min.interval	
200W	0	15min	40min	90min
100W	30sec.interval	1min.interval	5min.interval	

4 Start (Start heating)



Displays remaining time

5 The buzzer will beep 3 times when finish.

- If you forgot to take the food out, the buzzer will beep 5 times in an interval of one minute. The beep will stop on press "CANCEL" and open the door.
- Once cooking is completed will flash, and the fan may operate to **COOLING** the interior of the oven. Please to not unplug the power plug while the cooling fan is operating. Cooking can be continued even when the fan is operating. (However, there are some automatic menus that cannot be used.

The container is hot, take care while removing the container



- If heating is repeated, the 900W may automatically be reduced to 600W in order to protect the electrical components.
If the finish is not hot, please add heating time whilst monitoring the state under extension or manual microwave mode.
- There is a buzzing sound when the microwave starts and during the microwave operation, this is the operating sound during cooking and is not a malfunction.

⚠ WARNING



PROHIBIT

Do not overheat the food.

Overheat of food could result in smoke or fire.

- Referring to the standard for time setting on page 46, set the time setting modestly and heat as monitoring.



PROHIBIT

Do not set temperature too high when warming up beverage and greasy food

It boils right away when being taken out which will cause burn injuries.

- Beverage : Liquid such as Coffee · Milk · Soy Milk · Water · Yogurt Soup such as soy bean soup.
- Greasy food : Raw cream · batter etc.
- Thickened food : Curry, stew, soup with bits in, etc.
 - Before and after reheating beverage, it should be stirred thoroughly with a spoon.
 - Set the time modestly, and heat as monitoring food.

STEW

- Start with heat level at 600 W (▲) and switch to low 200 W (▼).
- Set by pressing the dial after matching the time for 600W with procedure 3. Then press the "START" button by matching the time for 200W.
- After heating for Microwave 600W completes, subsequently the remaining time for Microwave 200W will be displayed.



■ To adjust the time during cooking.

- The dial can be rotated to increase or decrease in steps of 1 minute during heating
- If the remaining time display for 900W, 600W, 500W is less than 5 mins, it can be increased or decreased in 10 second units.
- The time is initially set at 5 mins for 900W, 20 mins. for 600W and 500W, 90 mins for 200W and 100W. This include the possible increase in time.



■ For further heating, once cooking is complete. (EXTENSION)

- This is done by rotating the dial to set the time within 1 minute after the completion of cooking and the process has to be monitored.

■ Standard of output deployment

900W	600W	500W	200W	100W
High	Medium			Low
<ul style="list-style-type: none"> • Speedy heat 	<ul style="list-style-type: none"> • Boiled vegetable (preparation) • Reheat 	<ul style="list-style-type: none"> • Overall food • Frozen food • Food that easy to burst or explode 	<ul style="list-style-type: none"> • Stew 	<ul style="list-style-type: none"> • Defrost

● Wrap the food according to the menu

Normally, it is unnecessary to wrap the food to reheating. However, some food may need to be wrapped. For details, please check against the manual heating time settings guide (Page 46) or the cookbook.

● Frozen foods and popcorn

To heating commercially frozen food, refer to package instruction for setting up the power and time. Since the values are approximate, in case of insufficient heating, increase or decrease the time manually and monitor the process.

Tips

Do not use small quantities of mixed vegetable for heating. Spark may occur and food may get burnt or become dry.



Adjustment of temperature

Warming up at the desired temperature



Quantity for one person (150g) is considered as standard.

Example : Soften the butter

1 Place food at the center of the oven chamber (do not put a lid on or put wrap over it)

- Place inside a heat resistant container that can be used with the microwave that is shallow and of the right size for the amount of food then place in the center.
- If the inside is hot, please warm once the inside has cooled sufficiently.
(The infrared sensor doesn't work properly if the inside is hot)

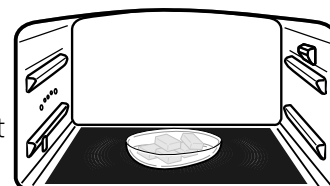

2 select DESIRED TEMP.



On pressing, it is the cycle change to

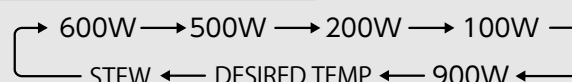

3 Rotate and select temperature from -10~90°C

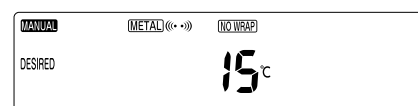

- Please refer to the page on the right for temperature settings.
- Standard amount is set at one person's (150g).
If there is a large amount, please set the temperature to be a little higher and set it to be a little lower when there is a smaller amount.
- Please do not set less than 100g of food to be more than 50°C .

4 Start (Start heating)



Displays remaining time from the middle.

5 The buzzer will beep 3 times when finish.

- If you forgot to take the food out, the buzzer will beep 5 times in an interval of one minute.
The beep will stop on press "CANCEL" and open the door.

■ For further heating, once cooking is complete. (EXTENSION)

→This is done by rotating the dial to set the time within 1 minute after the completion of cooking and the process has to be monitored.

■ The cooking temperature cannot be changed a part of the way through

Notice

- The infrared sensor reads the surface temperature of the food so the inside may not get to the temperature set. The inside of the food may be hotter or cooler than the temperature set depending on the type, thickness or flavouring of the food.
- The temperature at the end may differ depending on the size, shape and material of the container.
※If you don't use it correctly the finish may not be good. Moreover it will cause food to burn, smoulder or catch fire.

⚠ WARNING

⊘ Do not overheat food
Causes smoke and fire.
Prohibited • Heat as monitoring the progress.

⊘ Do not heat seals containers in oven that use infrared sensor mode (Page 20).
It is difficult to detect high temperature that builds up and the food may overheat. That may cause fire and container may be crack or broken.
Prohibited • Remove the lid of container before heating

For good result

Please read

Things to follow on Page 20 ~ 21 (Microwave heating using infrared sensor)

- **When reheating baby food or care food**
 - Take the food into a shallow container and reheat.
 - Frozen food can not be heated. Please use “MICROWAVE” button to cook manually instead. Observe the food carefully.
 - Before serving a baby, stir well and check the temperature of food.

Fully aware of!

● Please do not warm drinks with “Desired Temp.”. Please use the “drinks” button for milk and alcohol and times on page 46 for other drinks as reference and set the time on the smaller side and warm whilst monitoring the situation under the manual “MICROWAVE” mode.

Guide temperature setting

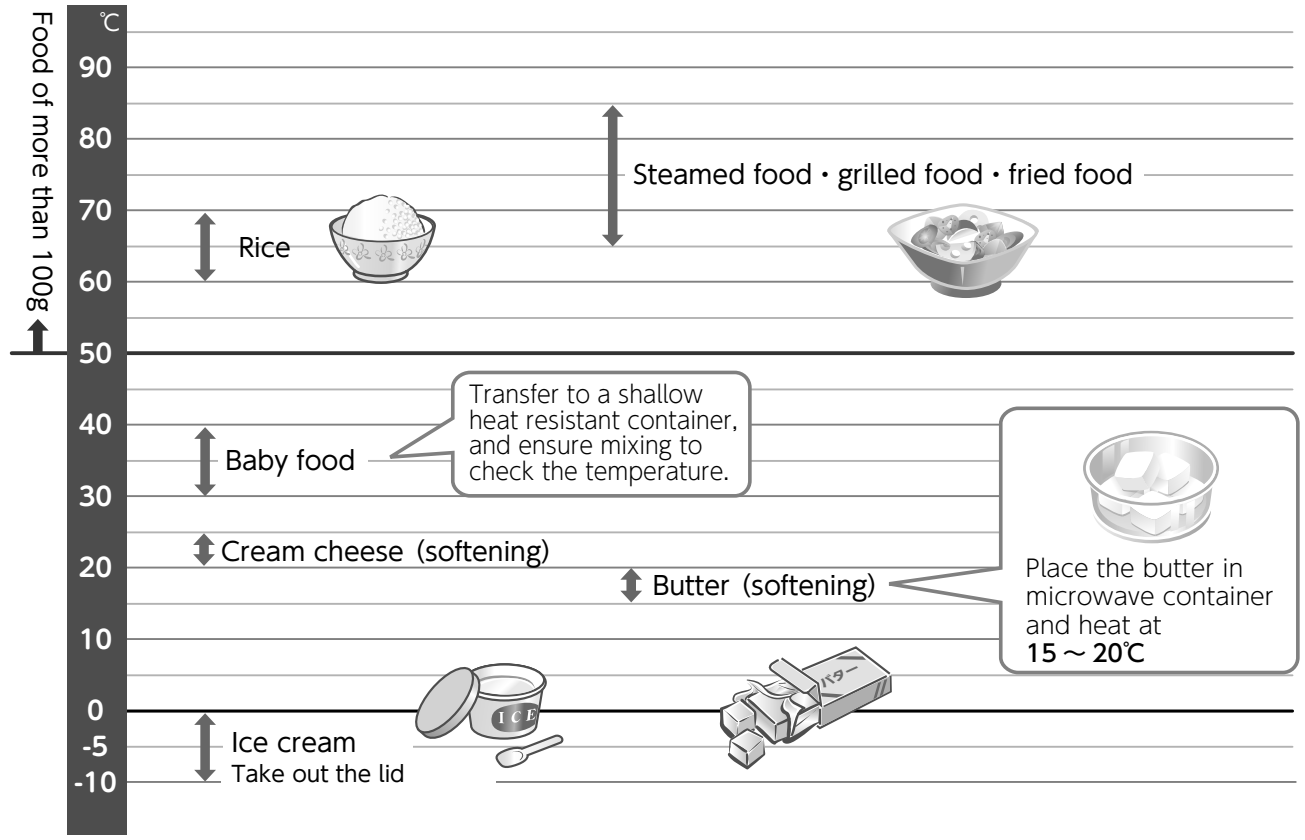

Manual cooking

Cooking with CONVECTION



With preheat

There is a menu for preheating with square plate in the cookbook.

1 Select Convection (with preheat)



※PREHEAT is displayed in the display unit.

On pressing, it is the cycle change to

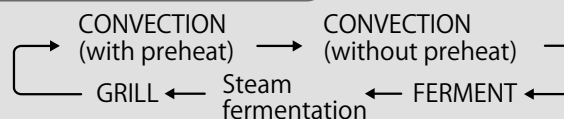

2 Adjusted the temperature



- Set temperature : 100 - 300°C, 350°C
- However when the chamber is hot ("HIGH TEMP." blinks on the display), you cannot set above 260°C to protect electric components.

3 Start (Start preheating)



- Display shows the remaining time 1 min. before preheat finish.

The buzzer will beep 5 times when finish preheating. (LCD displays "PREHEAT END")

- Preheat can be retained for approx. 20 minutes. (at 260-350°C, about 10 minutes).
If nothing is done during that time, buzzer sounds 3 times and preheating maintenance is finished.

4 Place the food into the chamber and adjust the time

(As accessory the cookbook is included as reference)



- Maximum time setting :
90 minutes (100~250°C)
60 minutes (260~300°C, 350°C)

■ Setting unit of cooking time

0	15min	40min	90min
30 sec. interval	1 min. interval	5 min. interval	

■ When you want to change the cooking temperature

Press after adjusting the time, and turn to increase or decrease the temperature by 10°C.

- If preheating is done with square tray, the square tray will be hot so please be careful when taking it out or placing food on it.

5 Start (Start cooking)



Displays remaining time

- If you press the "START" button after putting the food in, heating starts.
※After the end of preheating, even if you press the "START" button, it does not operate if the door is not opened and closed

6 The buzzer will beep 3 times when finish.

- If you forgot to take the food out, the buzzer will beep 5 times in an interval of one minute.
The beep will stop on press "CANCEL" and open the door.
- LCD displays "HIGH TEMP."

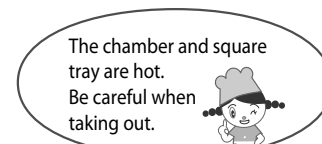

Setting temperature

The setting temperature of the oven is measured at the centre of the oven chamber using a thermoelectric thermometer. (JIS measurement method is used). The temperature may not match if the temperature is measured using commercially available thermometers

Preheat is : To heat the empty oven chamber and keep it warm at a particular temperature required to cook the dish.

- Temperature cannot be changed during preheating.
- If it is set to be 350°C, the pre-heating temperature is 300°C
- A guide for preheating times is: 200°C setting in around 5 min, 250°C setting in around 11 min and 300°C setting in around 20 min.

→ Time may slightly vary according to chamber temperature, room temperature, or voltages.

Without preheat

1 Place the food into the chamber
(As accessory the cookbook is included as reference)

2 Select Connection (without preheat)



※PREHEAT is displayed in the display unit.

On pressing, it is the cycle change to

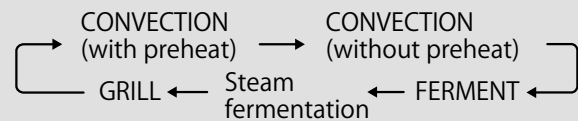

3 Adjust the temperature and press to confirm



- Set temperature : 100 - 300°C, 350°C
However when the chamber is hot (“HIGH TEMP.” blinks on the display), you cannot set above 260°C to protect electric components.

4 Adjust the time



- Maximum time setting : 90 minutes (100~250°C)
60 minutes (260~300°C, 350°C)



■ Setting unit of cooking time

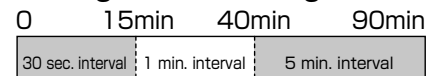

5 Start (Start cooking)



6 The buzzer will beep 3 times when finish.

- If you forgot to take the food out, the buzzer will beep 5 times in an interval of one minute. The beep will stop on press “CANCEL” and open the door.
- LCD displays “HIGH TEMP.”

The chamber and square tray are hot. Be careful when taking out.



■ To adjust the time during cooking.
→The dial can be rotated to increase or decrease

- Time which can be set for one cooking, including the amount of time you can increase it by, is up to the maximum time setting.

■ To adjust the temperature during cooking.
→The dial is pressed during heating, and while is flashing, the dial is rotated to increase or decrease.

■ For further heating, once cooking is complete. (EXTENSION)
→This is done by rotating the dial to set the time within 1 minute after the completion of cooking and the process has to be monitored.

- Depending on room temperature, initial temperature of food and the electric voltage, the final result may vary. If you turn the food during cooking or place aluminium foil on parts of the food, the food will finish well.

Tips

Since the square tray will be hot after cooking, Be careful.

- Please read the Safety precaution “Heater heating/Steam heating” on page 7.

Ferment

Ferment

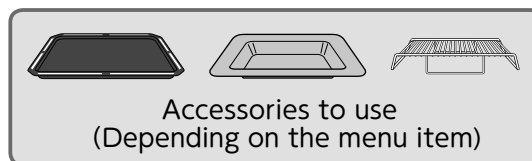

Fermentation, Steam fermentation

Used for ferment bread dough

1 Place the food into the chamber

(Put in the specified accessory into the specified location for menus from the cookbook)

- Steam fermentation prepares to supply water (see page 13). Insert the water tank until it touches the back.

2 Select Ferment or steam fermentation



On pressing, it is the cycle change to

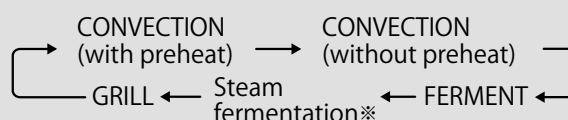

※Steam fermentation displays “ferment” and “steam” in the display area.

3 Adjust the temperature and press to confirm

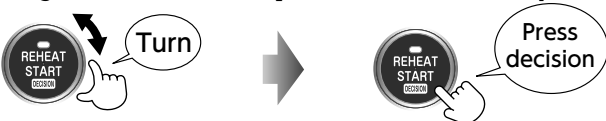

- Set temperature : 30°C /35°C /40°C /45°C

4 Adjust the time



■ Setting unit of cooking time (Max. 90min)

0	15min	40min	90min
30 sec. interval	1 min. interval	5 min. interval	

5 Start (Start fermentation)



Displays remaining time

- If the dough get dry, please cover with wrap or wet cloth, or spray with water.
- If the inside temperature and set temperature becomes close, the heater will not operate but it is not broken.
- Steam fermentation may not produce sufficient steam if the temperature inside is close to the temperature set.

6 The buzzer will beep 3 times when finish.

- If you forgot to take the food out, the buzzer will beep 5 times in an interval of one minute. The beep will stop on press “CANCEL” and open the door.
- Please remove water and maintain the pipe after finishing steam fermentation. (Page 51)

■ To adjust the time during cooking.

- The dial can be rotated to increase or decrease
- The maximum time set initially is 90 min. and include the possible increase in time.

■ For further heating, once cooking is complete. (EXTENSION)

- This is done by rotating the dial to set the time within 1 minute after the completion of cooking and the process has to be monitored

■ The cooking temperature cannot be changed a part of the way through

Cool the oven chamber and accessories sufficiently before fermentation.

If the LCD display shows “C21” “HIGH TEMP.”, press the “CANCEL” button, open the door and wait until the oven temperature drops down. If the temperature inside is very high, fermentation will not take place properly.

Manual cooking

Cooking with GRILL



Example : Grilled Fish

1 Place the food into the chamber

- Place gridiron on square tray, then place food on it and put in chamber.
- Because it is cooked with upper heater, upper layer is recommended.
- If the height of food is high, do not use gridiron to cook.

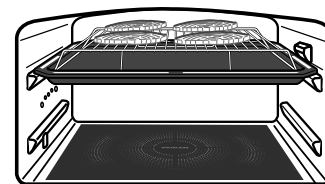

2 Select Grill



On pressing, it is the cycle change to

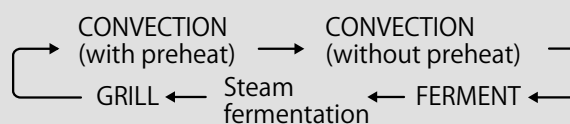

3 Adjust the time



■ Setting unit of cooking time (Max. 30min)

0	5min	10min	30min
10sec.interval	30sec.interval	1min.interval	

4 Start (Start cooking)



Displays remaining time

- For good result, turn the food during the process and press "START" again.

5 The buzzer will beep 3 times when finish.

- If you forgot to take the food out, the buzzer will beep 5 times in an interval of one minute. The beep will stop on press "CANCEL" and open the door.
- LCD displays "HIGH TEMP."

The chamber and square tray are hot. Be careful when taking out.



■ To adjust the time during cooking.

- The dial can be rotated to increase or decrease in steps of 1 minute during heating
- The maximum time set initially is 30 min. and include the possible increase in time.

■ For further heating, once cooking is complete. (EXTENSION)

- This is done by rotating the dial to set the time within 1 minute after the completion of cooking and the process has to be monitored.

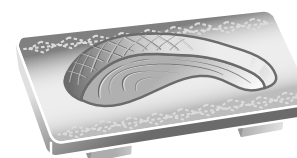

Tips

Since the square tray will be hot after cooking, Be careful.

- Please read the Safety precaution "Heater heating/Steam heating" on page 7.

Manual cooking

Cooking with steam

Cooking with Steamed / Steam Microwave

(Guide to time setting : page 46)

1 Prepare water tank and place the food into the chamber.

- Prepare water tank. (See page 13)
Insert the water tank until it touches the back.
- For steam microwave, place in a heat resistant container that can be used in the microwave and place directly in the center.

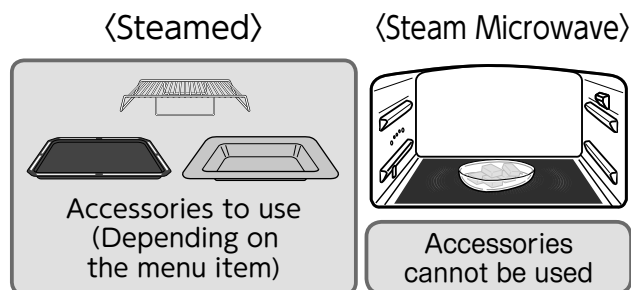

2 Select Steamed or Steam Microwave



Select by pressing

On pressing, it is the cycle change to

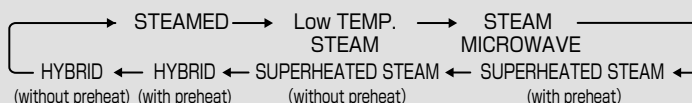

- Steamed : Cooking with steam only.
- Steam microwave : Cooking with microwave (400W) and steam. Please be careful of containers you use.
※Sparks come out with square tray and aluminium foil hence they cannot be used.
(((••))) is displayed

3 Adjust the time



■ Setting unit of cooking time (Max. 25min)

0	5min	10min	25min
10sec.interval	30sec.interval	1 min.interval	

4 Start (Start cooking)



- After pressing the "START" key, steam is produced after around a minute.



5 The buzzer will beep 3 times when finish.

- Be careful of hot steam when opening the door.
Please also be careful of steam coming out of the vent.
- If you forgot to take the food out, the buzzer will beep 5 times in an interval of one minute.
The beep will stop on press "CANCEL" and open the door.
- Please let the water out and maintain the pile. (Page 51)

The container is hot, take care while removing the container

Tips

Since the square tray will be hot after cooking, Be careful.

- If the door is opened during cooking, some steam may escape out.
Be careful of the steam coming out from steam exit outlet.
- Please read the safety precaution on "Heater heating/Steam heating" on page 7.

Please start cooking with Low Temp. Steam once the inside has cooled.

- If the inside temperature is high, cooking will not work well. If the display area displays "C21" "HIGH TEMP.", press the "CANCEL" button, open the door and wait until the temperature inside reduces.

Please check that there is no water in the drain tray before using steam.

Beware hot steam when taking the food out!

Cook with Low Temp. Steam (35~95°C)

1 Prepare water tank and place the food into the chamber.

- Prepare water tank. (See page 13)
Insert the water tank until it touches the back.

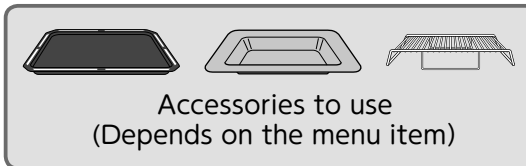

2 Select Low TEMP. steam



On pressing, it is the cycle change to

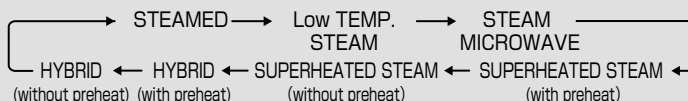

3 Adjust the temperature and press to confirm

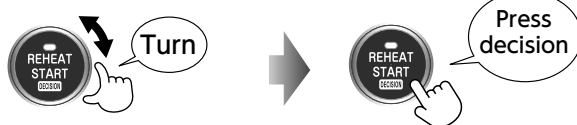

- Set temperature : 35~95°C

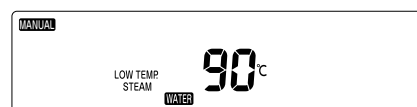

4 Adjust the time



■ Setting unit of cooking time (Max. 25min)

0	5min	10min	25min
10sec.interval	30sec.interval	1 min.interval	

5 Start (Start cooking)

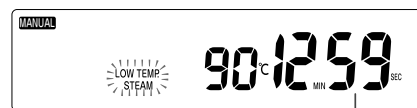

Displays remaining time

6 The buzzer will beep 3 times when finish.

- Be careful of hot steam when opening the door. Please also be careful of steam coming out of the vent.
- If you forgot to take the food out, the buzzer will beep 5 times in an interval of one minute. The beep will stop on press "CANCEL" and open the door.
- Please let the water out and maintain the pile. (Page 51)

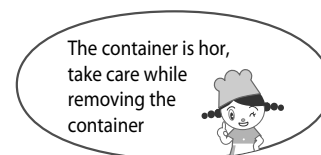

■ To adjust the time during cooking.

- The dial can be rotated to increase or decrease in steps of 1 minute during heating
- The maximum time set initially is 25 min. and include the possible increase in time.

■ To adjust the temperature during cooking. (only for Low Temp. Steam)

- Press the dial during heating and whilst the temperature set is flashing, turn the dial to change it by 5°C greater or less

■ When the water tank water runs out during cooking

- There will be a beep and the "WATER" display will start blinking. Add water in the water tank.
- "WATER" display will disappear once water is added. (Water can be added to the water tank, even during cooking operation.)

■ For further heating, once cooking is complete. (EXTENSION)

- This is done by rotating the dial to set the time within 1 minute after the completion of cooking and the process has to be monitored

Manual cooking

Cook with Superheated steam / Hybrid (steam)



With preheat

Due to the high temperature, superheated steam is not visible to the eye.

1 Prepare the water tank and choose Superheated Steam (with preheat) or hybrid (with preheat)



Select by pressing

- Prepare water tank. (See page 13)
Insert the water tank until it touches the back.
- ※ **PREHEAT** is displayed in the display unit.

On pressing, it is the cycle change to

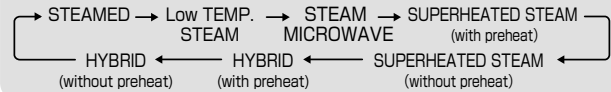

2 Adjust the temperature



Turn

- Set temperature : 100~250°C, 300°C
However when the chamber is hot ("HIGH TEMP." blinks on the display), you cannot set above 300°C to protect electric components.

3 Start (Start preheating)



Press

- Display shows the remaining time 1 min. before preheat finish.



The buzzer will beep 5 times when finish preheating. (LCD displays "PREHEAT END")

- Preheat can be retained for approx. 20 minutes. (at 300°C, about 10 minutes).
If nothing is done during that time, buzzer sounds 3 times and preheating maintenance is finished.

4 Place the food into the chamber and adjust the time



Turn

■ When you want to change the cooking temperature

Press after adjusting the time, and turn to increase or decrease the temperature by 10°C.

■ Setting unit of cooking time (Max. 60min)

0 15min 40min 60min

30sec.interval | 1min.interval | 5min.interval

- If preheating is done with square tray, the square tray will be hot so please be careful when taking it out or placing food on it.

5 Start (Start cooking)



Press

- If you press the "START" button after putting the food in, heating starts.
- ※ After the end of preheating, even if you press the "START" button, it does not operate if the door is not opened and closed



Displays remaining time

6 The buzzer will beep 3 times when finish.

- Be careful of hot steam when opening the door.
And remaining steam may come out from the outlet. Be careful.
- If you forgot to take the food out, the buzzer will beep 5 times in an interval of one minute. The beep will stop on press "CANCEL" and open the door.
- Please let the water out and maintain the pile. (Page 51)
- LCD displays "HIGH TEMP."

The chamber and square tray are hot. Be careful when taking out.



- The state of finish differs depending on room temperature, shape, amount, size, initial temperature, inside temperature, power voltage, etc.
If you turn the food around during heating or cover it partially with aluminium foil, it will finish evenly.
- Steam comes out when the inside gets hot.

Preheat is : To heat the empty oven chamber and keep it warm at a particular temperature required to cook the dish.

- Temperature cannot be changed during preheating.
 - A guide for preheating times is: 200°C setting in around 5 min, 250°C setting in around 11 min and 300°C setting in around 20 min.
- Time may slightly vary according to chamber temperature, room temperature, or voltages.

Superheated steam ... Cooking with steam heated to a temperature greater than 100°C.
Hybrid ... Superheated steam and strong fire heater are used to heat.

Without preheat

1 Prepare to supply water, put food inside and select superheated steam (without preheat) or hybrid (without preheat)

(As accessory the cookbook is included as reference)



Select by pressing

On pressing, it is the cycle change to

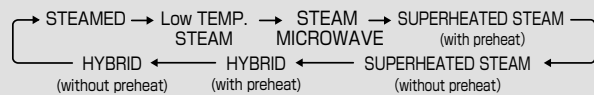

- Prepare water tank. (See page 13)
Insert the water tank until it touches the back.
- ※**PREHEAT** will not be displayed.

2 Adjust the temperature and press to confirm



Turn



Press decision

- Set temperature : 100~250°C, 300°C
However when the chamber is hot ("HIGH TEMP." blinks on the display), you cannot set above 300°C to protect electric components.

3 Adjust the time



Turn



■ Setting unit of cooking time (Max. 60min)

0 15min 40min 60min

30sec.interval | 1min.interval | 5min.interval

4 Start (Start cooking)



Press

5 The buzzer will beep 3 times when finish.

- Be careful of hot steam when opening the door.
And remaining steam may come out from the outlet. Be careful.
- If you forgot to take the food out, the buzzer will beep 5 times in an interval of one minute. The beep will stop on press "CANCEL" and open the door.
- Please let the water out and maintain the pile. (Page 51)
- LCD displays "HIGH TEMP."

The chamber and square tray are hot. Be careful when taking out.

■ To adjust the time during cooking.

→The dial can be rotated to increase or decrease

- The maximum time set initially is 60 min. and include the possible increase in time.

■ To adjust the temperature during cooking.

→The dial is pressed during heating, and while is flashing, the dial is rotated to increase or decrease.

■ When the water tank water runs out during cooking

→There will be a beep and the "WATER" display will start blinking. Add water in the water tank.

- "WATER" display will disappear once water is added. (Water can be added to the water tank, even during cooking operation.)

■ For further heating, once cooking is complete. (EXTENSION)

→This is done by rotating the dial to set the time within 1 minute after the completion of cooking and the process has to be monitored

Tips

Since the square tray will be hot after cooking, Be careful.

- Please read the safety precaution on "Heater heating/Steam heating" on page 7.

Beware hot steam when taking the food out!

Reference for manual heating's setting time

⚠ WARNING

⊘ Do not overheat the food.
Overheat of food could result in smoke or fire.

PROHIBIT

- During cooking should check food condition.

⊘ Do not give to much heat to beverage and food with oil or fat.
During taking out from the oven they will overheat and burn your hand.

PROHIBIT

- Before and after reheating beverage, it should be stirred thoroughly by a spoon.
- Set a shorter time and observe the condition of food.

Standard cooking time to set output and time.

The time should be balanced with the quantity of food. If the quantity of food is halved, the cooking time should be almost halved as well.

- Unit of quantity: ml=cc
- Normal temperature: Approx. 20°C, refrigerated: Approx. 10°C, Frozen: Approx. -20°C
- With wrap... ○ / Without wrap... ×

Reheat (Microwave 600W)

Menu	Quantity	Cooking Time	Wrap
Rice	1 cup (150g)	approx. 1 min	×
Rice Dish	1 cup (340g)	approx. 3 min	×
Soup	1 cup (150ml)	approx. 1 min 30 sec	×
Boiled Vegetable	150g	approx. 1 min 20 sec	×
Curry & Stews	200g	approx. 2 min 10 sec	○
Dumplings	6 pieces (100g)	approx. 50 sec	×
Chinese meat dumpling	1 piece (90)	approx. 40 sec	○
Butter Roll	2 pieces (70g)	approx. 20 sec	×
Toasted bread	1 piece (110g)	approx. 30 sec	×

Reheat Frozen Dish (Microwave 600W)

Menu	Quantity	Cooking Time	Wrap
Frozen Rice	1 cup (150g)	approx. 2 min 30 sec	○
Frozen Curry or Stew	200g	approx. 6 min	○
Frozen Shaomai	5 pieces (100g)	approx. 2 min ~ approx. 2 min 20 sec	○
Frozen Chinese Dumpling	1 piece (90g)	approx. 1 min 30 sec	○

Defrosting frozen meat or fish (Microwave 200W)

Menu	Quantity	Cooking Time	Wrap
Meat	100g	approx. 3 min	×
	200g	approx. 4 min 30 sec	×
	400g	approx. 9 min	×
	600g	approx. 12 min	×
Sashimi	100g	approx. 1 min 30 sec	×
	200g	approx. 3 min	×
	400g	approx. 5 min	×
	600g	approx. 7 min	×

Steam Food (Steamed) ※ Heat with square tray + gridiron (lower shelf)

Menu	Quantity	Cooking Time	Wrap
Chinese Dumpling	1 piece (90g)	approx. 15 min	×
Chinese Dumpling (Frozen)	1 piece (90g)	approx. 25 min	×
Shaomai (Refrigerated)	10 pieces (150g)	approx. 15 min	×
Shumai (Frozen)	10 pieces (150g)	approx. 20 min	×

- As for commercial frozen food or processed food, refer to the provision on the package to reheat as monitoring the process.



Metal containers, aluminum retort packs cannot be used for heating. It can cause fire, burst, cracks or breakage leading to the damage of the product, injuries or burns.

Beverage (Microwave 600W)

Menu	Quantity	Cooking Time	Wrap
Milk (Refrigerated)	1 cup (200ml)	approx. 1 min 40 sec	×
Sake (Room temperature)	1 cup (160ml)	approx. 1 min	×
Water (Room temperature)	1 cup (200ml)	approx. 1 min 20 sec	×
Coffee (Room temperature)	1 cup (150ml)	approx. 1 min 10 sec	×

Boiled Vegetable (Microwave 600W)

	Menu	Quantity	Cooking Time	Wrap
Leaf	Spinach	100g	approx. 1 min 50 sec	○
	Cabbage	100g	approx. 2 min 10 sec	○
	Broccoli	100g	approx. 1 min 40 sec	○
Root	Potato	1 piece (150g)	approx. 3 min 30 sec	○
	Taro	100g	approx. 2 min 30 sec	○
	Squash	150g	approx. 3 min	○
	Carrot	100g	approx. 1 min 50 sec	○

Defrost Frozen Boiled Vegetable (Microwave 600W)

Menu	Quantity	Cooking Time	Wrap
Green Soybean	100g	approx. 2 min 10 sec	○
Taro	100g	approx. 2 min 20 sec	○
Squash	150g	approx. 3 min	○
Mixed Vegetable	100g	approx. 2 min	○

※ Transfer to a heat resistant container, apply more water on mixed vegetables to heat.

Steam Heating (Microwave steam 400W)

Menu	Quantity	Cooking Time	Wrap
Rice (Refrigerated)	1 cup (150g)	approx. 1 min 30 sec	×
Chinese steamed buns (Refrigerated)	1 piece (90g)	approx. 1 min	×
Dumplings (Refrigerated)	10 pieces (150g)	approx. 1 min 50 sec	×
Rice (Frozen)	1 cup (150g)	approx. 3 min 40 sec	×
Chinese steamed buns (Frozen)	1 piece (90g)	approx. 2 min	×
Shumai (Frozen)	10 pieces (150g)	approx. 3 min 30 sec ~ approx. 4 min	×

About notification sound (buzzer)

Beep sound notification for following operations and conditions.



- When you press the button → Bip
- When the dial is turned whilst the display area shows "0" → Bip
- When cooking ends → Beep beep beep
- If there is a mid-way operation such as turning the food over during automatic cooking once the preheating has finished → Beep beep beep beep
- When 20 minutes has gone by without the door being opened or closed after the end of preheating (10 minutes with the 260-350°C setting) → Beep beep beep
(The cooking is discontinued)
- If the "REHEAT" button is pressed in the following situations → Bi bi bi bi bi (warming does not start)
 - It's been over a minute after opening and closing the door.
 - Door has not been opened and closed after the end of preheating.
 - When door has not been opened or closed following a notification buzzer such as turning food upside down during automatic cooking.※ Please press the "REHEAT" button once the door is opened and closed.
- If you forget to take food out after heating has finished → Bibeeep bibeeep bibeeep every minute
- If the door is not opened even after the notification buzzer such as to turn the food upside down with automatic cooking → Bibeeep bibeeep bibeeep every minute
- When there is abnormal display → Bi bi bi bi bi bi bi
- When water supplementary supply displaying,
 - When cooking discontinues temporarily → Bi bi bi bi bi bi bi
 - When cooking is not temporarily stopping → Bi bi bi every minute
- If the heating stops because the door is not properly closed → Bi bi bi bi bi

How to cancel the buzzing sound.

■ To cancel all the buzzer sounds

- 1 While displaying "0", press  and hold until you hear Bip Bip (Approx. 3 sec).
- 2 Continue to press .
Display area displays .

■ To stop the buzzer sound when forgot to take out the food

- 1 While displaying "0", press  and hold until you hear Bip Bip (Approx. 3 sec).
- 2 Continue to press .

- To restore the buzzer sound. → Repeat the steps of "How to cancel the buzzing sound".

How to do maintenance The frequency point to care and quick cleaning

⚠ WARNING



UNPLUG
AFTER
COOLS OFF

Unplug the power plug and let the machine body cool down before cleaning the body.

Or else, it may cause electric shock or burns.



PROHIBIT

Do not heat while oil, food particles or water exists inside of oven

The electric wave focuses on the dirty part and may cause sparkle, smoke, and fire.

- If something sticks, please wipe it off after the machine body is cooled down.



PROHIBIT ON
WET HAND

Do not unplug with wet hand.

It may cause electric shock.

⚠ CAUTION



Leave the door closed whilst removing water from the pipe

Steam is generated during water removal from the pipes in the same way as during steam cooking. It may cause burns hence leave the door closed.

Door and Cabinet

Wipe with well squeezed damp cloth.

- Wipe tough stains with mild soap and water and wipe clean with damp cloth.

Tips

- Do not use excess water. It may cause the oven to rust and result in damage.

Steam outlet

Wipe with well squeezed damp cloth.

- After steam cooking, white traces (dissolved matter in water) may remain near the steam outlet port. Wipe carefully with a firmly squeezed damp cloth.

Door (inside) • Chamber

Wipe with well squeezed damp cloth.

- Tough stains may be cleaned by soaking the area for 30 min. with mild soap and then cleaning it.

After steam heating, wipe each time any condensed moisture with a dry cloth after the oven cools down.

Tips

- Do not clean with any sharp-pointed implements such as scrub brush or fork, because they can cause scratches and cracks.

Door gasket

If water droplets and food remnants, etc. accumulate in the door gasket, wipe off gently with cooled and tightly wrung soft cloth.

Tips

- Please do not rub strongly or insert it in or pull it. It may lead to steam leaking. (Gasket cannot be taken off)

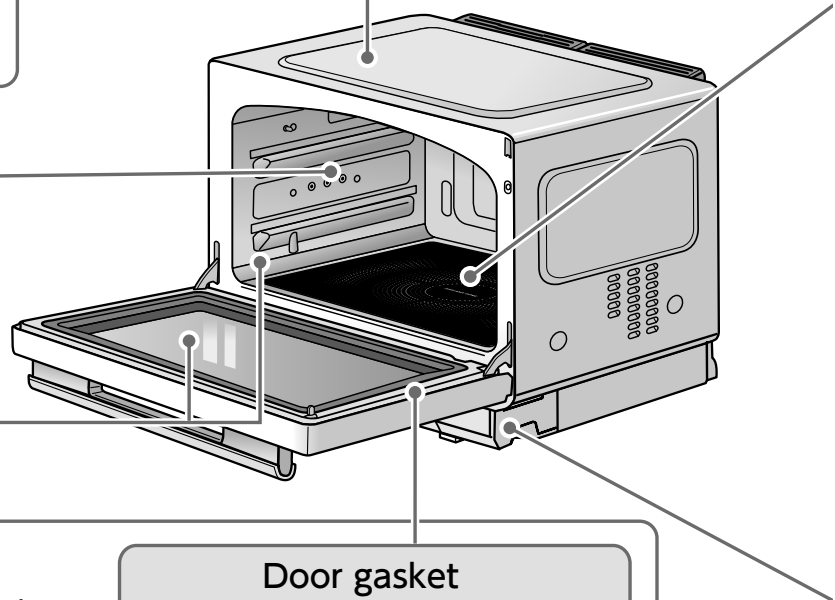

■ If the odor in the oven persists even after cleaning.

“Warming the empty oven” • Deodorize (Refer page 18). The odor intensity will reduce.

■ If oven is not to be used for long time.

After carrying out “pipe water removal” (See page 51), unplug the power plug from the socket and after maintaining each component, store so that there is no moisture or dust.

Tips

Please do not use furniture cleaners (alkali, acidic, etc.), oven cleaner, powder cleansers, benzene, thinners, boiling water, flammable gas (LPG, etc.) spray or scourers, hard part of a sponge brush, abrasive nylon sponge, metallic scourers.

It may cause damage, discolouration, deformation, smouldering, fire, rust, peeling of paint.



PROHIBIT

Sponge brush

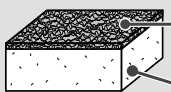

Do not use the hard side (Non woven fabrics with scrubs).

Use the soft sponge side for cleaning.

Abrasive nylon sponge

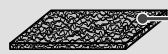

Do not use for cleaning. Use nonabrasive sponges for cleaning

Advice

It's also possible to lift the dirt on the inside, square tray, deep tray or gridiron by using steam. Please do it in accordance with “How to clean with steam system” on page 50. (Please do not use any methods other than those shown on page 50)

Bottom of the chamber

Wipe off any dirt or food particle with a soft damp cloth.

If microwave is used, the food particle may burn.

- If the dirt is hard to get off, please apply liquid cleanser (cream cleanser) to the dirty area, leave for around two minutes and rub off the dirt by rubbing with wrap film scrunched up into a ball. Then please wipe away the washing up liquid afterwards with a wet cloth.

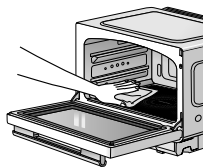

Tips

- The surrounding silicone gasket or the inside areas that are painted will be damaged so please do not rub.
- Please do not rub with metallic scourers or pointy objects. It may get damaged or crack.

Water Tank • Drain Tray

Dispose of the water in the water tank and drain tray. If it's dirty, remove the dirt with a soft sponge and water and then wipe away the moisture properly.

- If you notice dirt, please wash off by diluting kitchen cleaners (neutral).



Tips

- If drying, please do not place in a dishwasher or put in direct sunlight. It may cause deformation and damage.

Square tray (metal • deep tray) • gridiron

Wash using a soft sponge and washing up liquid for kitchen (neutral) and wipe off the water sufficiently.

- Please wash away dirt that doesn't disappear easily by soaking it in luke warm water first.
- For tough food particles, use steam to clean. (Refer page 50 for How to clean with steam system).
- If moisture remains on the square tray (metal • deep tray) or gridiron, rust may form
- When dirt cannot easily be removed from a deep tray



Please rub with a melamine form sponge (white sponge with which you don't need to use washing up liquid) to get it off.



Tips

- Please do not to cool down immediately after using. It may cause damage or deformation. Moreover, steam may generate if water is put on immediately after heating or hot splashes may be produced.
- Please do not rub with metallic scourer or with something with a sharp tip. It may get damaged or become deformed.

Air intake port

Remove the water tank and drain tray, then remove dust with a Hoover.

- If dust accumulates in the air intake port, electrical components may not be cooled, potentially causing damage.

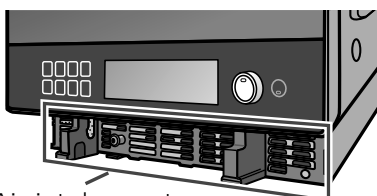

Air intake port

How to do maintenance (continued)

When you care of stains

How to clean with steam system

Use steam to make stains in the chamber float to make easier to wipe off.
If you put square tray or gridiron that you want to clean in the chamber, it will be easier to remove the stains.
It takes **3 minutes** to clean.

1 Set the water tank into the main body.

- * When you want to remove dirt from grills or square trays these can be placed in the oven chamber.
- Prepare water tank. (See page 13)

2 Select **49 Quick Cleaning**



- If you turn left, you can select quicker.

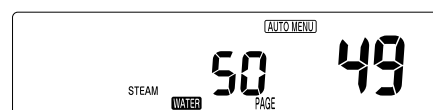

3 Start (Cleaning Start)

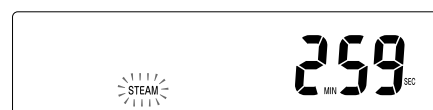

4 The buzzer beep 3 times when no hassle maintenance is complete

- Be careful of hot steam when opening the door.
And remaining steam may come out from the outlet. Be careful.
- Please remove water from the pipe after finishing. (Page 51)
- Unplug the power plug from the socket and once the temperature of the inside, square tray and gridiron has come down sufficiently, please remove the dirt by wiping.
- After steamed process, discard the water in the water tank and draining tray completely and wash them with water.
- Wipe the moisture inside the oven chamber with a dry cloth after the oven cools down.

Notice

- After the steamed operation, the oven, square tray and gridiron will be hot. Be careful.
- No hassle maintenance can reduce smells but not all kinds of odours can be removed.

When using steam

How to draining water from the pipe

Please remove water from the pipe after completing the cooking using steam. Cleaning time is **2 minutes**.

1 Remove the water tank from the oven.

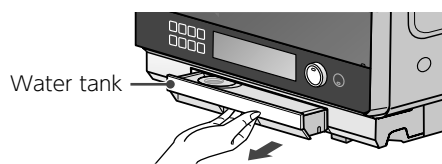

2 Select 50 Water Removal.



- If you turn left, you can select quicker.

3 Press start to remove water.



4 The buzzer beeps 3 times and the water draining operation is complete.

- After the end, if the inside or the door is wet with water droplets, please wipe with a dry cloth once the main body has cooled down.

Notice

- During the operation do not press any key or perform any other operation.
- During the operation, keep the oven door closed. The water that get drained is converted to steam that escapes from the steam outlet, be careful.

About Cleaning

After cooking, please wipe off the water droplets remaining inside or attached to the door with a dry cloth, etc. once the main body has cooled, each time.

If steam cooking is repeated with water droplets still remaining inside or on the door, water may overflow out of the drain tray.

1 Wipe away the water droplets inside or on the door with a dry cloth

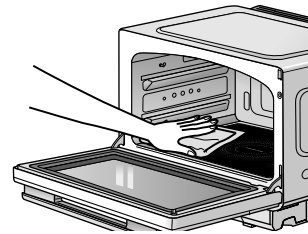

2 Dispose of the water remaining in the water tank and wash with water

- See page 49 for How to do maintenance

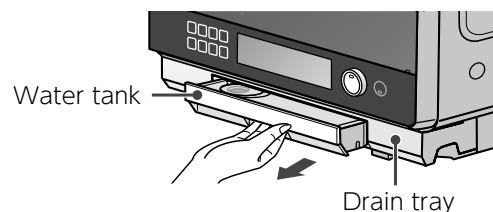

3 Dispose of the water in the drain tray

- See page 49 for How to do maintenance

4 Insert the water tank and drain tray back to the oven.

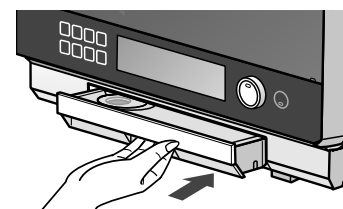

How to affix / remove water tank and drain tray please see page 13.

Common inquiry

Q. Question	A. Answers	Refer to page
Should the oven be placed from the wall and furniture at a distance?	<p>Yes, It is necessary The furniture and the wall may overheat and cause damage and fire.</p> <ul style="list-style-type: none"> • Please leave a gap of more than 10cm on top. • There is no need to leave a gap on the left, right, behind or the bottom. <p>However if there are walls, home electrics, furniture or plugs that's not strong against the heat, please leave a gap greater than indicated.</p> <ul style="list-style-type: none"> • Ensure there is sufficient space in the front to open the door fully and take the food out. 	4
Should the appliance be earthed?	Yes, Always use the power outlet with earth socket.	4
Is it necessary to operate the oven empty and deodorize?	<p>Yes, It is necessary. When using the oven for the first time, operate the oven empty and deodorize to burn away any oil or grease. There may be smoke or smell. But it does not denote malfunction.</p>	18
How can dirt or grease be removed?	Refer to [How to do maintenance] instruction for clean up operation.	48 { 51
What sort of containers can we use?	Refer to [Vessels you can use / Vessels you can't use] guide.	16 { 17
What is the method to drain the any excess water?	Refer to [How to draining water from the pipe] instruction guide.	51
What is the method to shift the product?	Please hold the left and the right side of the product properly and carry it.	8
The base surface gets hot after using the product - is that ok?	<p>After continued use, long-term heating or oven cooking, the base and the wall surfaces get hot from the heat of the product.</p> <p>It's not abnormal but please be careful not to touch with bare hands until they've cooled Please do not use it on tatami mats, carpets or table cloths that are weak to heat.</p>	—

In case you can't cook well

Microwave heating and Steam heating

Item	Condition	How to
Reheat rice and dishes	Cooking finishes immediately It doesn't heat up even when you warm with "Auto Reheat"	<ul style="list-style-type: none"> ● If the inside (especially the bottom surface) temperature is high, the infrared sensor may not operate properly. Open the door and wait for cool down completely and then heat.
	Food does is not reheat.	<ul style="list-style-type: none"> ● Is the food shielded with metal container or aluminum foil. ● Are you not using the attached square tray? Square tray cannot be used. ● Please place the food in the center inside. If the position is not right, it may not warm properly. ● After heating for a long time, continued heating or heating of small amounts, it may not heat up well due to protection of electric components. Please use it after some time.
	It gets too hot if you warm with "Auto Reheat"	<ul style="list-style-type: none"> ● Are you using ceramic or glass lid? Do not use lid or cover. →Infrared sensor may not work properly ● Please place the food in the center inside. If the position is not right, it may not warm properly. ● Is the quantity too small? Heat more than 100g at one time. ● For the infrared sensor to detect the temperature of the food, use a container which is shorter and that has wide mouth.
	Rice become very dry.	<ul style="list-style-type: none"> ● Sprinkle water on the food before cooking to moisten it. ● Use "STEAM MICROWAVE" to heat for moist results.
	Water splashes when boiling food or fish.	<ul style="list-style-type: none"> ● Please place in a deep container and cover with wrap and warm it whilst monitoring the situation under the manual "MICROWAVE" mode.
	Curry and stews is not reheat.	<ul style="list-style-type: none"> ● Heat thick foods with "2 Sides dish" mode monitoring the progress. (See page 23)
	Frozen rice is not reheat.	<ul style="list-style-type: none"> ● If the surface is partially melted or new wrap is put over the top, the infrared sensor may not operate properly. Use the one that has been just taken out from the freezer. ● When you freeze, make wrap fit tight on the rice to wrap. ● Do not overlap wraps or roll for multiple times. ● When you reheat, do not face up the side wraps overlapped to place food to reheat.
	Frozen food is not reheat.	<ul style="list-style-type: none"> ● If the surface is partially melted or new wrap is put over the top, the infrared sensor may not operate properly. Use the one that has been just taken out from the freezer. In addition, cover the food making sure that the wrap touch the food. ● You may not be able to reheat commercial frozen food with automatic "Reheat". Follow the instruction on the package and reheat with manual "Microwave" monitoring the process.
	Dried food	<ul style="list-style-type: none"> ● Use "STEAM MICROWAVE" to heat for moist results.
	Fried food such as Tempura becomes sloppy.	<ul style="list-style-type: none"> ● Reheating with "24 Crispy Reheat" will make a crispy finish.
	Two dishes cannot be heated properly.	<ul style="list-style-type: none"> ● Aren't you placing food around the edge? ● Is the quantity too much to reheat? ● If side dish is too much for rice, it cannot be reheated well. ● According to types of food or combination of quantity, it may cause not reheating well. →If you could not reheat well, heat the food manually with "MICROWAVE" monitoring the process.

Notice

Common inquiry / In case you can't cook well

In case you can't cook well (continued)

Item	Condition	How to
3 types Defrost	Food does not defrost properly.	<ul style="list-style-type: none"> ● Please place food flat on top of a shallow polystyrene tray or kitchen paper and defrost. → If food is inside deep polystyrene tray, the temperature cannot be measured properly due to the edges of the tray and it may not defrost well. ● Foods of thickness up to 3cm can be defrosted well. Please make the thickness even and wrap aluminium foil on the thin parts or places like fish tail. (See page 30) ● To defrost more than two pieces at the same time, ensure that the pieces are of the same size and thickness. ● It may not defrost well depending on form and type.
	Insufficient Defrost	<ul style="list-style-type: none"> ● If the temperature of the food increases partially, the heating may stop because of the infrared sensor and some of the food may remain insufficiently defrosted. → If there are thick or narrow parts of the food, it can easily become partially heated, so please defrost by making all the thickness the same. → Please defrost the insufficiently defrosted parts under the manual "MICROWAVE 200W" whilst monitoring the situation. → If the surface is slightly melted or a new wrap is put over the top, infrared sensor may not work properly. Use the one that has been just taken out from the freezer.
Milk · Sake	The operation time is too short. The beverage temperature is still low.	<ul style="list-style-type: none"> ● If the inside (especially the bottom surface) temperature is high, the infrared sensor may not operate properly. Open the door and wait for cool down completely and then heat.
	Milk become overheat after heating.	<ul style="list-style-type: none"> ● Have you selected "16 Milk" with the "BEVERAGE" button? "REHEAT" button makes it too hot so please don't use it. ● How much is the quantity? Pour 80% of the container. It may boil over if only a small amount is put in relative to the container. ● Please use containers described on page 27.
	Sake beverage become overheat after heating.	<ul style="list-style-type: none"> ● Have you selected "17 Sake" with the "BEVERAGE" button? "REHEAT" button makes it too hot so please don't use it. ● How much is the quantity? Pour 80% of the container. It may boil over if only a small amount is put in relative to the container. ● Please use containers described on page 27.
	The top and the bottom of the liquid are different temperature.	<ul style="list-style-type: none"> ● Mix after heating. ● When using the sake bottle (ceramic), cover the neck of the bottle with an aluminum foil so that the vertical difference is reduced. (See page 27)
Boiled vegetables	Food does not get fully Cooked	<ul style="list-style-type: none"> ● Does it have a lid on? Please do not use a lid. Please cover root vegetables on each flat plate. With leafy vegetables, please wrap only around the food and not over the plate. Moreover, please place the part where the wrap overlaps on the bottom and place on the plate. ● If the amount is less than 100g, please heat under the manual "MICROWAVE 600W" mode whilst monitoring the situation.
	Vegetables (Leaves/Roots) tends to be dry.	<ul style="list-style-type: none"> ● Please wash the vegetables and cook without getting rid of the water on them. Please splash water on it as required.
	Food is boiled unevenly.	<ul style="list-style-type: none"> ● Please make pumpkin and potatoes about the same size. Put root and leaves on top of each other alternately with spinach, etc. ● Take it out after heating and leave as is for about 5 minutes. ● To cook more than 2 pieces at the same time, arrange the vegetable according to the size for uniform cooking.

Microwave heating, Steam heating and Heater heating

Item	Condition	How to
Steam reheat	Takes long time for cook.	<ul style="list-style-type: none"> ● Since heating is done by generating steam, takes more time than heating using only the microwave. ● If faster cooking is desired, rather than moist finish, use “1 Cooked rice”
Desired temp	If cooking completes faster, then temperature of the food is low.	<ul style="list-style-type: none"> ● If the inside (especially the bottom surface) temperature is high, the infrared sensor may not operate properly. ● Open the door and wait for cool down completely and then heat.
Steamed food	Food is not steam properly.	<ul style="list-style-type: none"> ● Are you using right quantity? The food may not turn out well if the quantity mentioned in the cookbook is changed. ● Is the water tank empty? If the water is less, the steam may not be formed and cooking will not yield best result. ● Ensure that the water tank is fitted inside properly.
Overall steam	In general, steam cooking does not happen properly.	<ul style="list-style-type: none"> ● Is the water tank empty? If the water is less, the steam may not be formed and cooking will not yield best result. ● Ensure that the water tank is fitted inside properly.
Overall convection heating	The result will be bad Uneven Browning	<ul style="list-style-type: none"> ● The grilling result may vary depending on the room temperature, form, quantity, size, initial temperature and power supply voltage etc. Heat while monitoring the progress. ● There will be uneven browning if the size of the dough is not uniform. Prepare the dough with uniform size. ● If you are concerned about the uneven browning, keep changing the front and back of the food or the upper and lower shelves of the square tray during heating. Also, the result will be good if partially covered with aluminum foil. ● The result may not be good with the temperature given in the recipe depending on the condition of the mould. In such cases, set the temperature higher or lower by 10 ~20°C than the temperature given in the recipe.
Fermentation	Cannot ferment well	<ul style="list-style-type: none"> ● According to room temperature, temperature of dough, types of yeast, proportion of materials etc., the condition of fermentation varies. Adjust fermentation temperature and time as monitoring the dough. ● If dough gets dry, splay on it as monitoring.
Toast	Burning color is too mild/ intense	<ul style="list-style-type: none"> ● For adjusting finishing, if you want it thin, set “Decrease”, and “Increase” if you want it thick. ● Burning colors vary according to thickness of bread, size, proportion, types of bread, amount of water, room temperature, temperature of chamber, timing to flip over. ● If burning temperature is thin, face up the side you wish to add burning, and use extension heating or manual “GRILL” to grill little by little as monitoring the state.

Notice

In case you can't cook well (continued)





In case you can't cook well (continued)

Item	Condition	How to	
Dessert	Sponge cake	The cake is not light and fluffy.	<ul style="list-style-type: none"> ● Are the egg beaten well? Beat them until smooth and uniform. ● Are the eggs frequently stirred after they are mixed with flour?
		The ingredient are not beaten well.	<ul style="list-style-type: none"> ● If the container contains moisture or oil, the mixture cannot be beaten well. ● Use container that does not contain oil or moisture.
		The flour is still lumpy.	<ul style="list-style-type: none"> ● Did you sieve the flour? Sieving removes the coarse particles and aerates the flour. ● Did you blend the flour uniformly?
		The cake sinks in the middle	<ul style="list-style-type: none"> ● Did you beaten the egg for too long?
		The crust is too dark.	<ul style="list-style-type: none"> ● If the ingredient and size differs from in the cook book, the crust color may change. Monitor the process and check the color.
	Chiffon cake	The cake is not light and fluffy.	<ul style="list-style-type: none"> ● Beat the white egg well, so that the mixture is thick and not free flowing even when the bowl is turned. It is easy to beat white egg if it is chilled.
		The center of the cake has cavity.	<ul style="list-style-type: none"> ● When the dough is poured into the mold, it get aerated. Ensure that the dough is poured from a considerable height and immediately ● Was an aluminum mould used?
	Profiterole	The puff is not fluffy.	<ul style="list-style-type: none"> ● Was the quantity correctly measured? ● When baking, was the microwave set at the right temperature?
	Cookie	The color is irregular.	<ul style="list-style-type: none"> ● Is the size and thickness of the mould the same.
	Bread	Butter roll	It is hard and not rise properly.
The color is not uniform.			<ul style="list-style-type: none"> ● Were the bread pieces arranged properly according to their size? Ensure that the pieces are arranged properly and the same size.
French bread		Not best result.	<ul style="list-style-type: none"> ● Please see "Tips on baking French bread" on page 167 of the cookbook.
Grill	Gratin	The color is irregular.	<ul style="list-style-type: none"> ● The color of the food may vary depending on the quality of cheese. Monitor the process while cooking.

Meaning of indicators and what to do

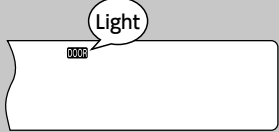
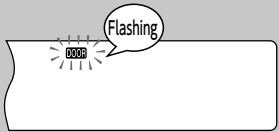
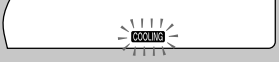
Notice

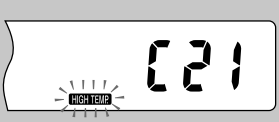
In case you can't cook well (continued) / Meaning of indicators and what to do

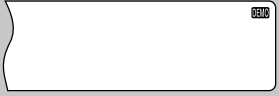
Display	Cause	How to
"Door" appears 	<ul style="list-style-type: none"> Will be displayed if "REHEAT" is pressed after more than 1 minute once the door has been closed. 	<ul style="list-style-type: none"> Open and close the door again. Press the key within 1 min. of door closing.
	<ul style="list-style-type: none"> Once the notification buzzer for turning over during automatic cooking or after the preheating has ended sounds, it is displayed if it is started without opening or closing the door. 	<ul style="list-style-type: none"> Please follow the instructions in the cookbook, then close the door and press the "START" button.
"Door" appears 	<ul style="list-style-type: none"> It's displayed when the door is not properly closed. It's not being heated. 	<ul style="list-style-type: none"> Please remove objects stuck between the door and the main body or things trapped in between (clothes or food remains, etc.). Please ensure that the door is properly closed and press the "START" key.
"COOLING" appears 	<ul style="list-style-type: none"> It is displayed after repeated microwave heating or after cooking with heater heating when the main body is being cooled. 	<ul style="list-style-type: none"> You can still cook while displaying. (However, there are auto menus that you cannot use.)
"WATER" appears 	<ul style="list-style-type: none"> Displayed when there is no water in the water tank. 	<ul style="list-style-type: none"> Please put water into the water tank and attach. The supply water display will disappear after a while and cooking will continue. Please press the "START" key if it's stopped temporarily.
	<ul style="list-style-type: none"> If there is water in the water tank, water cannot be collected well. 	<ul style="list-style-type: none"> Ensure that the water tank is fitted inside properly.
"HIGH TEMP." appears 	<ul style="list-style-type: none"> It is displayed when the inside is hot such as after the end of heater heating. 	<ul style="list-style-type: none"> Open the door and wait the oven cool down. (After 15~20 mins., the display will disappear. It is possible to press the "CANCEL" button and choose different menu while the display is on.)
"C21" "HIGH TEMP." appears 	<ul style="list-style-type: none"> It is displayed if "fermentation" "3 types of defrosting" are set and started when the inside temperature is high after heater heating. 	<ul style="list-style-type: none"> Press "CANCEL" button and open the door. Please wait until the temperature cool down.
	<ul style="list-style-type: none"> It is displayed if "Reheat" "Desired Temp." are set and a part of the menu is started when the inside temperature is high after heater heating. 	<ul style="list-style-type: none"> Press "CANCEL" button and open the door. Please wait until the temperature cool down. ("Microwave" can be used by manual. However we can not use "Desired Temp.")
"C24" appears 	<ul style="list-style-type: none"> If a small amount of food (or without putting food inside) is heated or you've repeatedly heated, the electrical components may become hot and operation may be stopped for safety. 	<ul style="list-style-type: none"> Please press the "CANCEL" button after a while then use it. Please increase the amount of food if a small amount of food is heated.
"DEMO" appears 	<ul style="list-style-type: none"> It is in the demo mode for shop displays. (Heating does not start even when you press the button) Please cancel by following the procedures in the treatment column on the right. 	<ul style="list-style-type: none"> If the following operation is repeated twice, it will be cancelled. Press the "CANCEL" button until the buzzer sounds (about 3 second) and press the "CANCEL" button.

When H○○ is displayed		
Display	Cause	How to
"H" appears 	<ul style="list-style-type: none"> Occurs during product failure of breakdown. 	<ul style="list-style-type: none"> Disconnect the plug and contact your dealer or qualified Toshiba Service.

Before asking for repairs

The following situations does not signify product malfunction

Effect	Reason (Measure)
There is no display after the electric plug is connected to the power supply.	<ul style="list-style-type: none"> • If the plug is connected to the power supply with the door closed, the power supply will be cut off. Open the door once to ON the power supply.
Ticking sound during cooking	<ul style="list-style-type: none"> • This is the switching sound of the switch inside the oven. This is not a malfunction.
Continuous noise during heater Operation	<ul style="list-style-type: none"> • It is the sound of the wall or square tray caused by heat shrinking and it is not broken.
Continuous noise (ji....) during microwave cooking.	<ul style="list-style-type: none"> • Noise is due to microwave cooking operation. Does not denote Malfunction
This noise becomes louder during cooking with noise (fan) or not during and after cooking	<ul style="list-style-type: none"> • During cooking or after cooking, cooling fan may turn on but that's not a break. Whilst the cooling fan is going around after cooking, the "COOLING" display flashes. Please to not unplug the power plug while the cooling fan is operating.
No display occurs when key is pressed.	<ul style="list-style-type: none"> • This is because the power is turned off 5 minutes after opening the door for energy saving. (Please operate once the power is on after opening the door)
If the door is opened, the control panel displays "0"	<ul style="list-style-type: none"> • When the door is opened, the power supply is connected. • "0" is displayed when power is supplied.
Bibeep bibeep bibeep Buzzer occurs one minute after cooking is over.	<ul style="list-style-type: none"> • A function has been provided to sound the buzzer if the food is not removed from the oven after the completion of cooking. This is not a malfunction.
Steam does not come out Water in the water tank doesn't reduce	<ul style="list-style-type: none"> • Check if the water tank is fitted properly and add water to it. • When the oven gets heated, the steam may not be visible. • During steam fermentation, sufficient steam will not be generated if the room temperature is close to the setting temperature. Spray monitoring the status. • Depending on the menu, the amount of water reduction in the water tank will differ and in some cases only a small amount will remain.
Hissing sound during steam cooking.	<ul style="list-style-type: none"> • Noise occurs when water gets converted to steam upon heating by steam heater. The noise may be loud when used initially.
Oven door becomes foggy	<ul style="list-style-type: none"> • During or after cooking, the glass door turns foggy or cloudy. It does not denote malfunction. The effect subsides after 2 hours. When the oven is Warming the empty oven · deodorize, the effect subsides in 30 min. (Refer to page 18)
After cooking, Water droplets adhere to the inside and inside of the door Water droplets fall Water accumulates inside	<ul style="list-style-type: none"> • There is high adhesion of the door in order to improve the cooking hence depending on the menu, water vapour from food may adhere to the door or the inside. Please wipe the water droplets off with a dry cloth after they have cooled. Moreover, if the surface on which it is installed is weak or topped, water droplets can easily drop. Please place on a flat surface with plenty of strength.
The inside light doesn't come on during preheating	<ul style="list-style-type: none"> • The design is such that the inside light does not come on during preheating. If you press the "INSIDE LIGHT" button during preheating, it can be switched on. (Refer to page 10)
Steam leaks from the gap between the door and the oven.	<ul style="list-style-type: none"> • According to the amount of steam or room temperature, steam may leak but there is no impact on performances such as cooking. Also there is no leak of radio wave during microwave cooking.
There is smoke and smell.	<ul style="list-style-type: none"> • When the oven is used for the first time, an unpleasant smell may be released due to the burning of the rust prevention oil. • Did you warming the empty oven · deodorize? • Is the oven or the door dirty?
During oven cooking, the LCD display is not visible.	<ul style="list-style-type: none"> • The LCD display turns dark at high temperature and may not be visible. This is due to the property of LCD and does not signify malfunction. When the oven temperature decreases, the LCD display is visible.
White powder and water are released from the steam outlet port.	<ul style="list-style-type: none"> • The white powder is harmless minerals such as magnesium and calcium contained in tap water. (Refer to page 13, 48)

Effect	Reason (Measure)
Spark occurs during cooking.	<ul style="list-style-type: none"> • Did you use the square tray? Do not use square tray inside microwave. • Did you use metallic container, wire mesh or metallic spits for menus to use microwave? • Metal skewers, containers or metal objects etc. may cause spark. • Is the oven dirty? Radio waves tend to converge on the dirt and cause spark. Please wipe away any dirt. (Page 48, 49)
The temperature in the oven is not the same as set temperature	<ul style="list-style-type: none"> • The temperature is measured by heat electric thermometer on the center with nothing inside (using JIS measurement method). When measuring using commercially available oven thermometer, the temperature tracking is slower compared to JIS' measurement options hence it takes longer to get to the set temperature. • When making meals please use the temperature in the cookbook as a guide.
In some cases, we cannot set the value over 260°C	<ul style="list-style-type: none"> • If the inside is hot, for protection of electric components, oven cannot be set to be hotter than 260° C and super-heated steam or hybrid cannot be set above 300° C.
There may be insufficient heating of the food with microwave heating.	<ul style="list-style-type: none"> • If there is a small amount of food or inside temperature is high after continued use, the output may be stopped to protect the product. It's not a breakdown.
It's stopped during cooking.	<ul style="list-style-type: none"> • Did you open the door during heating? Please press the "START" button after closing the door • Automatic cooking with work required during heating will be notified by the buzzer sounding 5 times. Please carry out the operation with the door open and press the "START" key after closing the door.

Check the following before calling for service center.

Effect	Reason (Measure)
Microwave does not work.	<ul style="list-style-type: none"> • Is the power supply ON? • Is the power plug disconnected? • Check if the circuit breaker or fuse power is off. • Did you open or close the door during cooking and forgot to press "START" Button? • Did you perform any key operation while the power supply is off? (Once you open the door, power will turn off the "0" is displayed)
Oven does not heat up on pressing "REHEAT" button.	<ul style="list-style-type: none"> • Is "DOOR" displayed. If the start key is pressed 1 min after the oven closes, heating will not take place. (Open and close the door again and press the key.)
It doesn't get heated even if the "REHEAT" button is pressed "NON-FRIED/HYBRID" "DEEP TRAY MENU". Press the "QUICK/EASY" "BEVERAGE" buttons. It doesn't heat up even when "START" key is pressed.	<ul style="list-style-type: none"> • Is the [HIGH TEMP.] display ON? (If the oven temperature is pressing the high, heating may not start in start key certain menu operation. Open the door, allow the oven to cool, wait for [HIGH TEMP.] disappear and press the key.) • Check if demo mode is ON. Refer page 57 for "DEMO" display instructions.
Buzzer does not work	<ul style="list-style-type: none"> • Check if the buzzer function is set to cancel mode. Refer Buzzer sound settings in (page 47) to change the buzzer settings
Cooking does yield desirable results.	<ul style="list-style-type: none"> • Did you follow the instructions properly. (Check instruction guidelines for the usage of lid, wrap and oven accessories) • Did you start cooking when the oven was hot. (Wait for the oven to cool.) • Did you use the appropriate food quantity. • Is the top part or bottom part of the oven dirty. • Did you select the right menu before cooking. • If case you can't cook well, refer (page 53~56) for guidelines.
"START" button does not operate sometimes.	<ul style="list-style-type: none"> • Close the oven door, wait for some time and then start. (Sometimes the oven does not start immediately after door close to prevent any malfunction.)
Circuit breaker has tripped	<ul style="list-style-type: none"> • Are the electrical appliances used exceeding the household electric capacity (Contracted capacity A with the power company). Switch OFF the power supply of other electrical appliances that are not required. Switch on the circuit breaker and reuse the oven.

~memo~

~memo~

Specification

Model name	ER-TD5000HK ER-TD5000C	ER-TD5000SG	
Power supply	AC 220 V 50 Hz	AC 230 V 50 Hz	
Power consumption	Microwave 1430W, Heater 1430W		
Microwave output	900W ^{※1} /600W/500W/200W equivalent/100W equivalent Output switching		
Microwave frequency	2450MHz		
Heater power output	Convection 1410W/Grill 1100W/Steam 1000W		
Temperature adjustment	100~300 · 350°C ^{※2} , Low temperature steamed (35~95°C ^{※3}), Fermentation (30, 35, 40, 45°C), Steam fermentation (30, 35, 40, 45°C)		
Body dimension	498 (width) ×440* include handle (depth) ×396 (height) mm		
Cavity dimension	394 (width) ×314 (depth) ×232 (height) mm		
Body weight	Approx. 21kg	Cavity volume	30L
Timer limits	Microwave 900W: 5 minutes Steamed/Low Temp. Steam/Steam microwave: 25 minutes Microwave 600W/Microwave 500W : 20 minutes, Grill : 30 minutes Microwave 200W/Microwave 100W/Ferment/Steam ferment : 90 minutes Convection (100~250°C) : 90 minutes Convection (260~300°C, 350°C) : 60 minutes Superheated steam/Hybrid : 60 minutes		

※1 Rated microwave output 900W is a short duration high power function (maximum 5 minutes) and rated continuous microwave output is 600W. The microwave power automatically changes to 600W.

※2 The operating time at 350°C is approximately 5 minutes. After that it automatically switches to 230°C. Even if you set the temperature above 260°C, it will automatically lowered to 230°C. Temperature that can be set with super-heated steam or hybrid is up to 300°C. When the temperature set is 350°C, the pre-heating temperature is 300°C. The temperature is measured by heat electric thermometer in the central part with nothing on the inside. (Based on JIS measuring method) The temperature may not match if measurement is taken with food or accessory inside. (If cooking a recipe, please use the temperature in the cookbook as a guide)

※3 The temperature is measured on the black aluminium (Pseudo load) in the middle of a corner plate placed on the lower shelf.

- Since the actual power consumed depends on the frequency of usage, duration, quantity and the surrounding temperature, monitor the process carefully.
- The electricity consumed when the power plug is plugged in, the door is closed and the display area is not lit is "0" W.
- Annual power consumption is the value in accordance with the Energy saving laws/Specified device "Microwave" measurement methods.
- The cavity volume is based on JIS (Japan Industrial Standard) specifications.

Please check up your microwave you are using for so long!		
 Affectionate checking	Don't you have symptoms like this?	<input type="checkbox"/> The power cord or plug is abnormally hot. <input type="checkbox"/> Food does not heat up even after cooking starts on pressing the key. <input type="checkbox"/> Oven does not switch off automatically. <input type="checkbox"/> Strange noise or smell occurs during use. <input type="checkbox"/> Oven wall or cover is dirty and spark or smoke occurs. <input type="checkbox"/> Other abnormalities or failure occurs.
		Stop using the oven To prevent damage due to failure, disconnect the power cord from the power supply and contact your dealer for repair or service. (Do not allow anyone other than a qualified technician to disassemble the unit.)