

INSTRUCTION MANUAL

Steam Oven with Microwave function

MX1-TH23SC(WH)

Please review this instruction manual before operating.

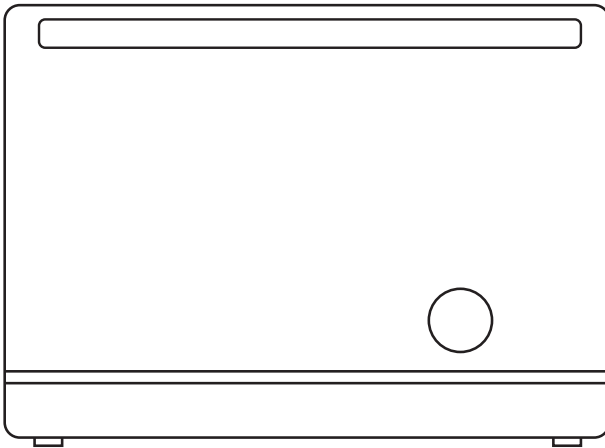

TOSHIBA

Contents

Safety guides

Unpacking inspection	3
Safety precautions	3
Selection of cooking utensils.....	5

Manual

Structure description	6
First use	6
Fittings.....	7
Usage of water tank.....	7
Introduction of the control panel	8
Quick heating	8
Microwave power.....	9
Pure Steam	10
Roast function (without preheating).....	11
Roast function (with preheating).....	11
Thawing function.....	12
Automatic Menu.....	13

Cleaning and maintenance

Precautions for cleaning	16
Scale cleaning.....	16
Sterilization.....	17
Microwave fault self-checking..	18
Product parameters.....	18

Repair and maintenance

Repair and maintenance.....	19
-----------------------------	----

Unpacking inspection

Please check the following after opening the package

1. Whether the body cover is deformed due to impact or pressure.
2. Whether the abutment between the oven door and the control panel is flat, and whether the door is opened smoothly.
3. Whether the metal insulation mesh on the oven door is bent or deformed.
4. Whether the power cord is damaged or loose.
5. Whether the data on the nameplate of the microwave oven is consistent with the local power grid.

Microwave oven placement

To prevent the oil, smoke, steam, etc. discharged from the exhaust port during cooking from staining the furniture or causing fire due to overheating. Microwave ovens shall be kept at a certain distance from walls and cabinets. Please place them according to the safe distance marked in the figure below.

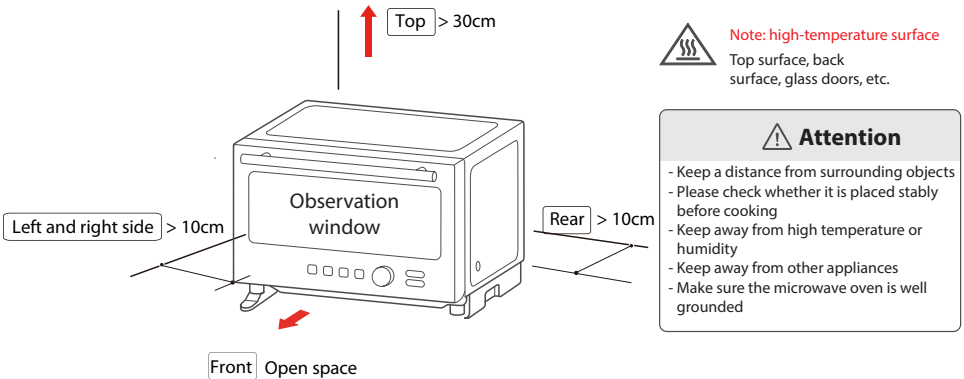

Safety precautions

To avoid injuries or property loss, the product body and its manual record important contents such as how to operate the microwave ovens properly and safely; besides, the icons and pictorial symbols, which may be different from the real products, are to help users understand. Please read the relevant marks carefully before use and rigorously follow them; please keep the manual properly for future reference.

Environmental considerations

- **It is forbidden to approach inflammable or heat-labile objects. Microwave ovens cannot be placed in cabinets**

Precautions for use

- **Please tear off the protective film on the cover before use**

Only the temperature sensing probe recommended for this microwave oven can be used

- **The elderly and children shall use microwave ovens with caution**

Warning: Children can use microwave ovens without supervision only when they are fully instructed so that they know how to use them safely and understand that incorrect use will give rise to danger. When the appliances work integrally, children must use them under the supervision of adults due to the temperature rise. The elderly shall use the microwave oven accompanied by their family.

- **High-temperature surface, prevent scalding.**

Microwave ovens will heat up during use. Avoid touching the heating unit in the microwave oven.

- **Warning:** The touchable part may be heated during use, so children shall stay away. During the operation, some surfaces may be heated to a high temperature. Surfaces labeled "high-temperature surface" will become scalding during use.



- **Do not put foreign matters into the suction port, exhaust port and oven door interlock switch**

Including metal objects, fingers, etc., to prevent electric shock and microwave leakage. Please unplug the appliance and contact our maintenance customer service center immediately in case of foreign matters.

- **Like steam cooking, self-cleaning also generates steam. Please close the oven door to avoid scalding.**

- **Please use microwave cooking utensils**

Warning: Only suitable utensils can be used in the microwave oven. It is forbidden to heat the liquid and other food in the sealed container, which may explode. Please tear up the package and put it in a special vessel for the microwave oven before heating.

- **Excessive heating of liquids such as soups and drinks will cause delayed splash boiling, so care must be taken when taking them out.**

Milk bottles and baby food cans shall be stirred or shaken. Before feeding, check the food temperature in the bottle to avoid scalding.

- **Excessive heating shall be avoided**

If a small amount of food is heated for a long time, the temperature in the oven chamber will be abnormally high, causing smoke, fire or vessel cracking. When heating food packaged in plastic or paper, pay attention to the microwave oven because it may catch fire.

- **Watch out for smoke**

Turn off the switch or unplug the appliance in case of smoke and keep the oven door closed to curb the flame. The appliance cannot operate when connected to an external timer or under the independent remote control system.

- **Remove all packaging and keep away from infants and young children**

Including the packing bag, cover film and fittings to avoid fire during operation; keep the above objects away from infants to prevent asphyxia caused by misuse.

- **It is forbidden to cook eggs with shells**

Microwave ovens cannot be used to heat fresh eggs with shells and cooked eggs, which may explode when or even after heating.

Precautions for repair and maintenance

- **It is forbidden to disassemble the cover for repair and transformation without authorization**

Warning: The maintenance operation, including removing the protective cover to prevent microwave energy leakage, is dangerous for personnel other than qualified maintenance personnel.

- **Be careful when opening and closing the door. If the door body is deformed, there will be a risk of microwave leakage.**

Warning: If the microwave oven door or door seal is damaged, it shall not be used again until it is repaired by qualified maintenance personnel.

- **Do not bend or stretch the power cord**

Damaged power cords must be replaced with special cords or special components purchased from the manufacturer or maintenance department.



Suggestion: to avoid danger, power cords shall be replaced by professional personnel of the manufacturer.





- **Do not use the steaming cleaner**

- It is a domestic appliance, therefore, our company is not responsible for any problems arising from non-household use

Selection of cooking utensils

Before cooking, you must check whether the cooking utensils are suitable for the microwave oven; please do not use non-microwave utensils to cook food.

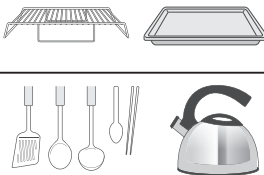
Suggested utensils	It is recommended to use special widemouthed heat-resistant ceramics or glassware for microwave oven; plasticware cannot be heated for a long time.	
		
Do not use	Heat-labile plastics and glassware	For example, carved and tempered glasses feature poor heat resistance and cannot be used for high-temperature cooking in microwave ovens.
	Lacquer	Cannot be used in microwave ovens. Paint may fall off due to high temperature.
	Wood, bamboo and paper products	Poor heat resistance, cannot be used for high-temperature cooking in microwave ovens.

Optional utensils	For example	Manual	Frequency conversion microwave	Frequency conversion Roast
Heat-resistant micro Porcelain ware		Ceramics and casseroles labeled "applicable to microwave ovens" can be used. However, containers decorated with gold and silver or glazed cannot be used.	✓	✓
Heat-resistant microwave Glassware		The most suitable container for microwave oven use and heating. Glassware is transparent and can be put onto the dinner table directly. The food inside can be seen clearly during cooking.	✓	✓
Heat-resistant microwave Plasticware		Lots of special plastics, which are made for microwave oven use, are also ideal microwave tableware.	✓	✗
Metalware		Metal cookware shall not be used in the microwave mode, but only in light wave or Roast, or combined Roast state. It is forbidden to put aluminum pot, stainless steel pot, metal spoon, chopsticks, knife and fork, spatula, kitchen knife, kettle, metal pot, etc. into the microwave oven.	✗	✓
Microwave steamer Microwave rice steamer		Applicable to microwave state only. Please add sufficient water to the base of the steamer and the rice steamer. Dry-braising is strictly prohibited.	✓	✗
Plastic wrap		The high-temperature-resistant plastic wrap can be used to prevent water evaporation in vegetables, but it can not be directly used for meat or fried food.	✓	✗

Note: the liquid (such as milk) volume shall not exceed two-thirds of the container.

Structure description

Please read the following contents firstly to quickly understand how to use our products

As our products are constantly upgrading, if there is any difference between the real object and the figure below, please take the former as the standard. It is a desktop product, and it is forbidden to be used as an embedded one.

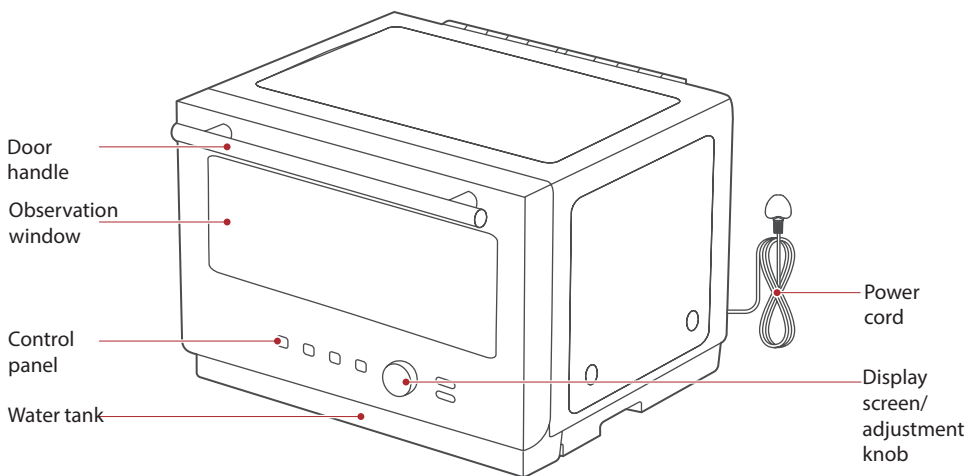

First use

Initial cleaning.

Remove all protective foils in front of the steaming oven. Before first use, refer to the "cleaning and maintenance" section for more information.

First cleaning and heating

Before heating, you'd better wipe the inside of the steaming oven with a wet cloth. In this way, the ash or residual packaging materials accumulated in the packaging process of storage and dissociation appliances can be removed.

Coated with a protective layer, the metal parts may generate a slight odor when heated for the first time. The odor will dissipate in a short time like the steam, which is not a token of faults in any connection or part. In addition, make sure that the kitchen is well ventilated during the first heating.

Please remove all fittings and clean them outside the oven.

New appliances usually generate odors when used for the first time. Before the first use, please turn to the Automatic Cleaning Function 39 to remove the odor

Manual

Fittings

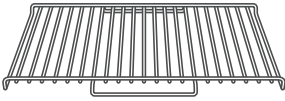

Steaming grill



Metal ovenware



Heat insulating gloves

Usage of water tank

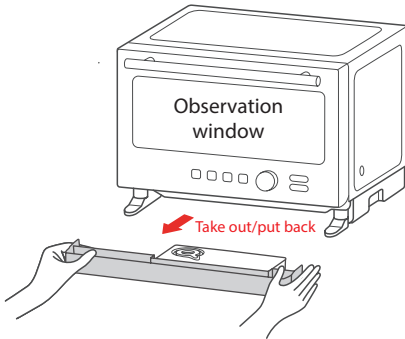

- Add **purified water** with a normal temperature (no more than 40 °C) into the water tank to prevent scale which may affect the service life of the oven.
- The water tank must be emptied after cooking to avoid bacterial breeding.

Water-adding method

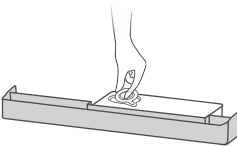

After opening the rubber ring, add an appropriate amount of **purified water** and cover the rubber ring to ensure that it fits well.

Cleaning method

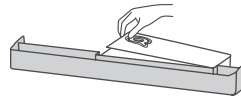

Open the water tank cover for cleaning or emptying the remaining water



1. Before use and after adding water into the purification tank, please close the water tank cover to prevent it from tilting and leaking.
2. The tank will buzz and display "△" if waterless. Please suspend cooking, fill the water tank and put it into the sink to restart cooking.
3. The pump will generate empty pumping noises if waterless, which is normal

Introduction of the control panel

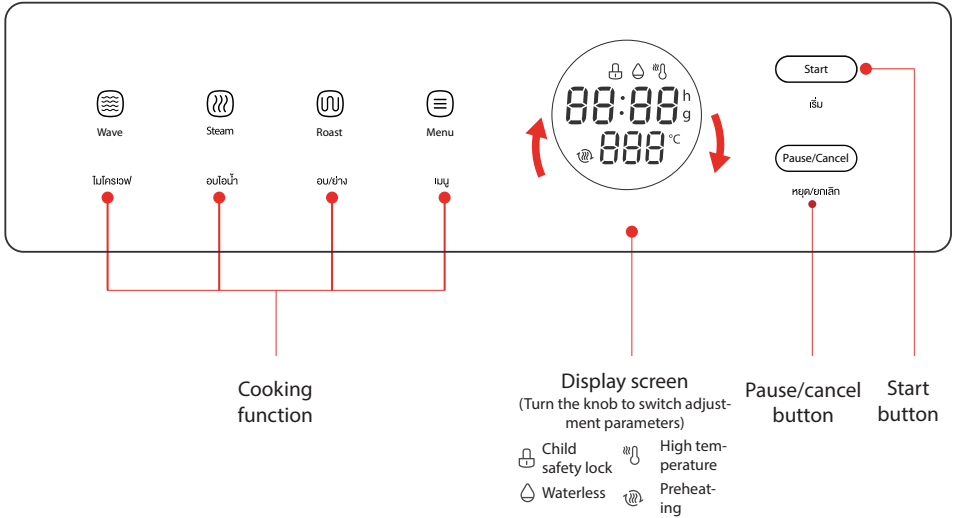

Quick heating (microwave function -P10)

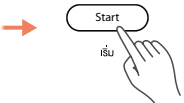
- 1 Turn the **knob** to select the cooking time or directly initiate it by pressing the adjustment knob. 
- 2 Press "**Start (เริ่ม)**" to cook. 



1. When initially used or powered on, the oven is in power saving mode and you shall open its door to activate the corresponding program.
2. It will automatically turn into the power-saving mode in case of 5-minute no-operation during the standby time.
3. During the standby time, press and hold the [Pause/Cancel (หยุด/ยกเลิก)] for 3 seconds to switch into the child safety lock mode, and the display shows "🔒"; press and hold it again for 3 seconds, the "🔒" disappears and you can exit the child safety lock mode.

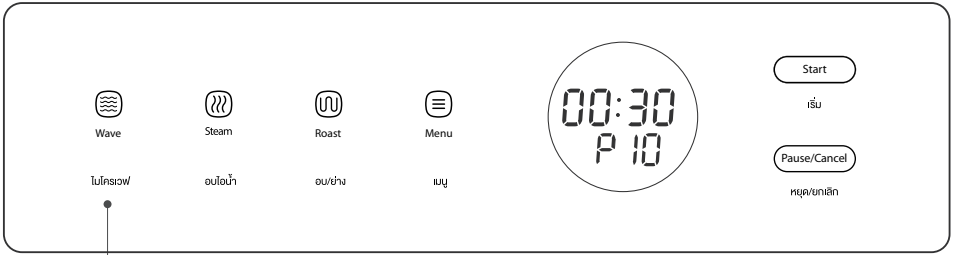

Microwave function

1 Press " Wave (ไมโครเวฟ) " to switch to the microwave function.

2 Turn the knob to set the cooking time.
Press the adjustment knob to confirm.
(Default time 30 seconds with a range from 5 seconds to 95 minutes)



3 Turn the knob to adjust the microwave power.

- P 10 1000W High setting
- P 08 800W Medium or high setting
- P 05 500W Medium setting
- P 03 300W Medium or low setting
- P 01 100W Low setting



4 Press " Start (เริ่ม) " to cook.

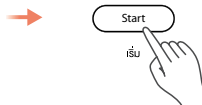

It is forbidden to use metal containers under the microwave function, for tin foil is made of metal.

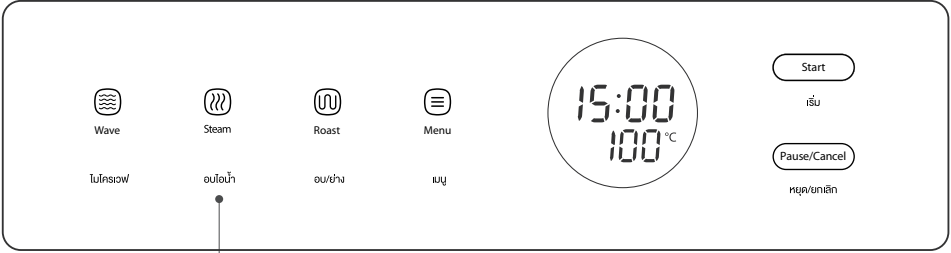

Pure Steam

1 Press “ **Steam (อบไอน้ำ)** ” to switch to the steaming function.

2 Turn the **knob** to set the cooking time.
Press the **adjustment knob** to confirm.
(Default time 15 minutes with a range from 5 seconds to 90 minutes)



3 Turn the **knob** to adjust the temperature.
(Range: 50 ~100°C)



4 Press “ **Start (เริ่ม)** ” to cook.

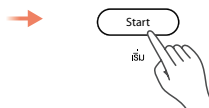

Attention

Add purified water with a normal temperature (no more than 40 °C) into the water tank when switching into the steaming function.

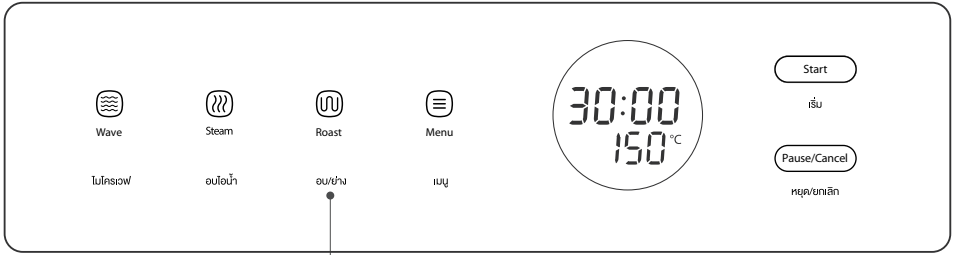

Roast function (without preheating)

- 1 Press "Roast (อบ/ย่าง)" once to switch to the Roast function without preheating.
- 2 Turn the knob to set the cooking time. Press the adjustment knob to confirm. (Range: 5 seconds - 90 minutes)
- 3 Turn the knob to select the Roast temperature. (Default temperature 150°C with a range of from 100°C to 230°C)
- 4 Press "Start (เริ่ม)" to cook.



Roast function (with preheating)

- 1 Press "Roast (อบ/ย่าง)" twice to switch into the Roast function with preheating.
- 2 Turn the knob to select the Roast temperature. Press "Start (เริ่ม)" to preheat. (Default temperature 150°C with a range of from 100°C to 230°C)
- 3 After preheating, the steam icon flashes. Open the oven door and put the food in. Turn the knob to set the cooking time. (Range: 5 seconds - 90 minutes)
- 4 Press "Start (เริ่ม)" to cook.

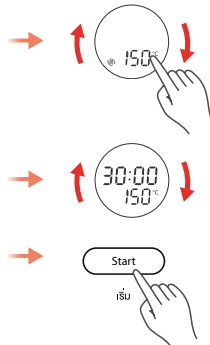

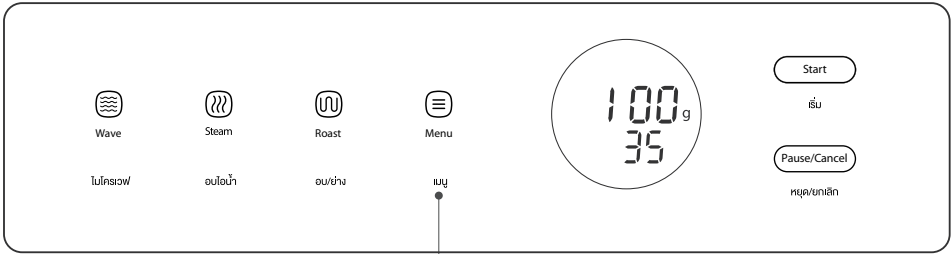

Menu - Rapid Defrost

1 Press " Menu (เมนู) " to switch to the automatic menu.

2 Turn the knob to select Menu 35. Press the adjustment knob to confirm.

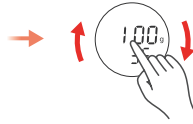

3 Turn the knob to select the thawing weight. (Default weight 100g with a range from 100g to 2000g)



4 Press " Start (เริ่ม) " to thaw.

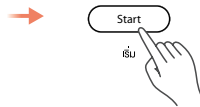

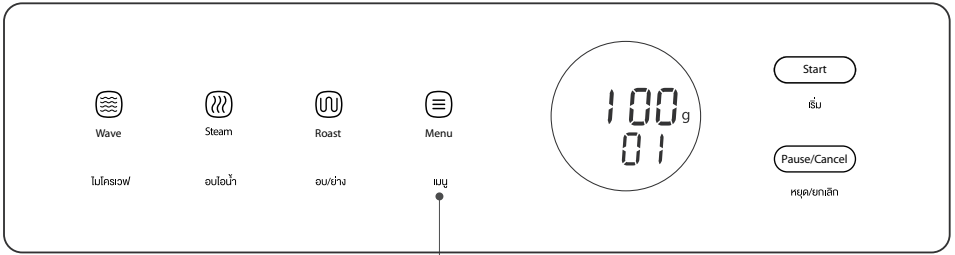

Menu

- 1 Press " Menu (เมนู) " to switch to the automatic menu.
- 2 Turn the knob to select the menu number. Press the adjustment knob to confirm the menu
- 3 Turn the knob to select the cooking time/quantity. (Preheating is required when its sign is on. Please preheat before putting the food inside)
- 4 Press " Start (เริ่ม) " or the adjustment knob to cook.

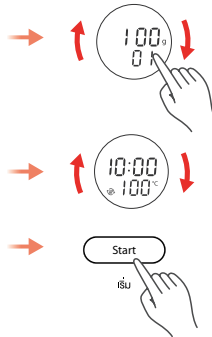

1. The automatic menu marked with "★" including the microwave. It is strictly prohibited to use metal containers, including tin foil paper.
2. Cooking with plastic wrap or cover comes off better but remember to punch holes!
3. Please be careful not to be scalded when taking out fittings or food.
4. If you hear the buzzes during cooking, please turn the food over and press [Start (เริ่ม)] to continue.
5. For the menu requiring [Preheat] in advance, preheat first according to the interface prompt, then put in the ingredients and press [Start (เริ่ม)] to cook.

Menu guide

No.	Menu name	Default portion	Default time	Preheating or not	Recommended container	Placement area
01	Wormwood Rice Cake	600g	12 min	/	Glass bowl + Steaming grill	Plate
02	Peacock Steamed Fish	700g	8 min	/	Saucer + Steaming grill	Plate
03	Spicy Lemon Chicken Feet	500g	15 min	/	Glass bowl	Plate
★ 04	Cucumber Flower Mixed Seafood	200g	5 min	/	Glass bowl	Plate
★ 05	Mango Pomelo Sago	30g	11 min	/	Glass bowl	Plate
★ 06	Braised Sirloin with Radish	250g	25 min	/	Wide-mouth deep bowl + cover	Plate
07	Steamed Siumai	400g	20 min	/	Steaming grill + ovenware	Lower layer
08	Steamed baby cabbage	500g	12 min	/	Saucer + Steaming grill	Plate
09	Steamed Sea Bass with Lime	400g	12.5 min	/	Saucer + Steaming grill	Plate
10	Steamed Chicken with Red Dates and Lyceum	500g	18 min	/	Saucer + Steaming grill	Plate
11	Steamed Tamago Tofu With Shrimp	200g	10 min	/	Saucer + Steaming grill	Plate
12	Steamed Fish Head with Chilli Pepper	600g	12 min	/	Saucer + Steaming grill	Plate
13	Steamed Hairy Crabs	6	12 min	/	Saucer + Steaming grill	Plate
★ 14	Braised Spicy Pork Knuckle	1000g	50 min	/	Wide-mouth deep bowl + cover	Plate
★ 15	Northeast China Soy Sauce	1000g	40 min	/	Wide-mouth deep bowl + cover	Plate
16	Sichuan Grilled Black Cod	250g	10 min	Yes	Ovenware	Lower layer
17	Roast Shrimp with Minced Garlic	500g	10 min	Yes	Ovenware	Upper layer
18	Honey Black Pepper Chicken Wings	12	25 min	Yes	Ovenware	Lower layer
19	Grilled Vegetable Skewers	4	16 min	Yes	Ovenware	Lower layer
20	Roasted saury	3	20 min	/	Ovenware	Lower layer
21	Roasted Steak with Black Pepper	250g	20 min	Yes	Ovenware	Lower layer
22	Wholemeal cube bread	3	35 min	Yes	Toast mold	Plate
23	Seafood Pizza	4	18.5 min	/	Ovenware	Lower layer
24	Cupcake	6	55 min	/	Ovenware	Lower layer
25	Cranberry cookies	/	12 min	Yes	Ovenware	Upper layer
26	Chiffon cake	500g	50 min	Yes	Ovenware	Lower layer
27	Caramel pudding	9	30 min	Yes	Ovenware	Lower layer
28	Butter Roll	9	17 min	Yes	Ovenware	Lower layer

No.	Menu name	Default portion	Default time	Preheating or not	Recommended container	Placement area
29	Thin Crust Pizza	1	20 min	Yes	Ovenware	Lower layer
30	Portuguese egg tarts	9	20 min	Yes	Ovenware	Lower layer
31	Japanese steamed egg custard	600g	21 min	/	Tea bowl + Steaming grill	Plate
★ 32	Japanese Style Stewed Meat with Potato	400g	8 min	/	Wide-mouth deep bowl + cover	Plate
33	Korean Spicy Squid	150g	8 min	Yes	Ovenware	Lower layer
34	Hamburger Steak	2	25 min	Yes	Ovenware	Lower layer
★ 35	Rapid Defrost	100~2000g	/	/	/	Plate
★ 36	Melted Butter	100g	2.5 min	/	Saucer	Plate
37	Dough fermentation	500g	50 min	/	Deep-mouth bowl	Plate
38	Yogurt Fermentation	1000g	6h	/	Deep-mouth bowl	Plate
39	Cavity Cleaning	/	10 min	/	/	Plate
40	Scale Cleaning	/	20 min	/	/	Plate
41	Disinfection	/	15 min	/	/	Plate



Attention

1. If the chamber temperature is higher than 65 °C , the icon “”, as a reminder of high temperature, is shown on the display screen, which is normal. Please pay attention to the high temperature to avoid being scalded.

Cleaning and maintenance

Precautions for cleaning



1. Do not use sharp cleaning tools, hard bristles, wire brushes or corrosive cleaning products to avoid damaging the oven body and its fittings.
2. It is strictly forbidden to immerse the microwave oven in water or other liquids to prevent it from being damaged.
3. Do not start cleaning or maintenance until the oven body cools down.
4. Do not leave the oven unattended if there are ingredients or dirt left inside to avoid fire.
5. Do not clean the oven with detergent, brush, banana oil, gasoline, etc.

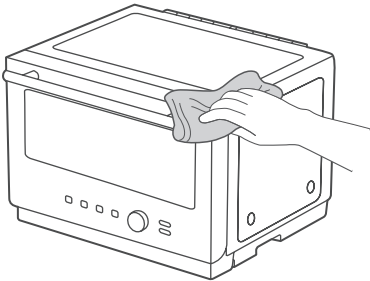

- 1 Unplug the microwave oven and cool it down before cleaning.
- 2 All fittings, including the grill and ovenware, shall be cleaned with neutral detergent then left to dry off.
- 3 Wipe the inside of the microwave oven with a soft damp cloth stained with neutral detergent, and then wipe off the detergent with a dry rag.

Scale cleaning

Once a month is recommended

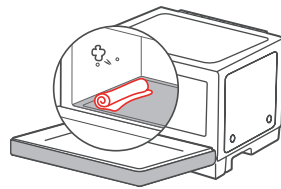
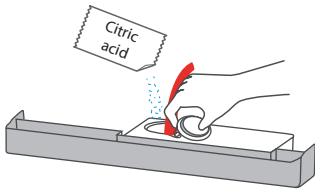

- 1 Take out the water purification tank, add about 15g of food-grade citric acid, fill the tank with purified water to dissolve the acid, and put the tank back.
- 2 Place a dry towel under the steam outlet on the left side of the oven chamber.

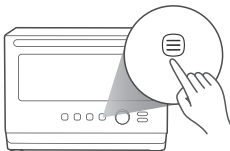

- Press " Menu (⋮) ", select **Menu 40** and press " Start (iSŪ) " to confirm.
- Empty the water tank and refill it with purified water after the oven displays "△" and prompts a sound; simultaneously, clean towels, oven chamber and waste water tank.
- After repeating the operation in Step 2, press " Start (iSŪ) " to continue cleaning.

Disinfection



Attention

1. The microwave features a strong sterilization effect on tableware such as ceramics and glass, with a sterilization rate of more than 99%.
2. Metal containers (including plates with gold or silver traces) shall not be used in microwave.
3. It is forbidden to adopt the sterilization function when there is no article in the oven chamber.

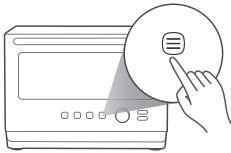

- 1 Press " Menu (⋮) " and select Menu 41.

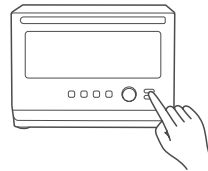

- 2 Press " Start (⏻) " to confirm

Tableware sterilization

The tableware shall be soaked in water before sterilization. Wrapping tableware with a wet towel helps improve the sterilization efficiency

Towel/rag sterilization

Towels/rags must be soaked in water and wrapped with plastic wrap before being put into the microwave oven for sterilization,

It can not only improve the sterilization effect but also prevent cotton from burning

Sterilization for nursing bottles

Separate the nursing bottle from the pacifier, fill the bottle with water of 70% volume and wrap it with plastic wrap, simultaneously,

Immerse the pacifier in the water container and press it with a small plate to prevent it from floating

Fault self-check of microwave ovens

The screen will prompt the error code "E****F**" (* is Arabic numerals) in case of faults. If the fault still cannot be eliminated after power on and restart, please contact Toshiba for help.

Description of common error codes		
Fault description	Display	Fault analysis
The chamber temperature is higher than 100°C .	F 0 1	It is normal

Product parameters

Volume	23L	Maximum steaming power	2000W
Rated voltage/frequency	220-230V~ 50Hz	Microwave operating frequency	2450MHz
Microwave input power	1450W	Overall dimensions (mm)	468x431x337
Microwave output power	900W	Chamber size (mm)	387x321x203
Maximum baking power	2000W	Net weight	16.9kg

1. Product size is approximate.
2. Overall dimension, depth includes door handle (if any) and tensile length of the rear plate, and height includes the oven foot.
3. The oven chamber size, including the tensile length, is the maximum between two surfaces.
4. Our products are regularly updated, therefore, the physical parameters may be different from those marked. Please refer to the former.

Repair and maintenance

Before maintenance, please read the following carefully if your microwave oven requires maintenance.

The following conditions are normal

- **Microwave oven interferes with TV reception.**

What interferes with radio and television is the electromagnetic wave generated by high-voltage transformers. This may also occur in some small electrical appliances and is not microwave oven failure. Toshiba microwave oven is equipped with an anti-leakage device of triple safety, and the microwave leakage is far below the national safety standard.

Please use a special instrument to test the microwave leakage.

- **The microwave oven lights are dim.**

If you choose "Microwave high setting" during cooking, the light inside will become dim and the oven will generate sound, which is normal.

- **The oven generates light and wind during cooking.**

An operating microwave oven will dissipate heat simultaneously, therefore, hot air will be discharged around the door and chassis. It is normal to see lights or smell the odors.

- **Steam accumulates in the oven door and hot air is discharged from the exhaust port.**

The steam from the food will be discharged from the exhaust port and condensed on the oven door during cooking. Or steam may overflow from the gap around the oven door. When using functions related to steaming, a large amount of steam will be generated in the chamber during the machine operation, and some steam may leak around the door crack, which is normal

- **Operating noises**

High voltage transformers, magnetrons and high-speed cooling fans will all generate noises, which is normal.

If the microwave oven cannot be started, please check whether

- It is not plugged in tightly:

Unplug it and plug it in again after 10 seconds.

- **The fuse blows or the circuit breaker works**

Reset the fuse or the circuit breaker (the professional maintenance personnel of our company are responsible for the repair).

- There is something wrong with the socket

Use other electrical appliances to test whether there is a problem with the socket. If the microwave oven cannot be heated, please check whether the oven door is closed. Please pay attention to closing the oven door.

Your microwave oven requires regular cleaning and maintenance.

- Please unplug the microwave oven promptly after use. Do not put it near the fire or immerse it in water. Do not put the power cord and plug directly on the cover to prevent the waste heat of the cover from damaging the power cord.

- Clean the microwave oven after it cools down. The microwave oven shall be cleaned regularly and all food residues inside shall be removed. Unclean microwave ovens will deteriorate the surface of the appliance, which will affect its service life and may lead to danger.

- The microwave oven shell can be wiped with a cloth dipped with soft detergent (such as detergent), then with a wet cloth, and finally with a dry cloth to desiccate the oven chamber. It is strictly prohibited to wipe the microwave oven with hard objects such as the steel wire brush. Do not clean the oven door safety lock system. **Warning:** Never use a crude detergent or a sharp metal scraper to clean the glass of the microwave oven door, because doing so may scratch or even crush the glass.

- The oil produced during cooking will corrode the oven chamber and affect the heating, thus changing the food flavor. Therefore, please clean the oven chamber promptly after use.

- Wash metal baking pans, ceramic pans and metal grills with warm water. Note that after cooking in the microwave oven for a long time, do not clean it instantly with cold water.

- Guided waves of the microwave oven can be divided into side-guided waves and bottom-guided waves. There is a waveguide port on the right side of the microwave oven chamber. Please keep the waveguide port clean and do not remove the waveguide cover (mica sheet) to avoid ignition.

- Details for cleaning the door seal, chamber and adjacent fittings; the microwave oven lying idle for a long period shall be made work for a few minutes under the Roast or lightwave function before reuse to evaporate the moisture accumulated in it.

- Keep the bottom of the oven chamber clean to avoid the abnormal noises caused by the rotating table during the operation of the rotary-table microwave oven.

#DetailsMatter

Contact Information

TOSHIBA CONTACT CENTER 0-2511-7777

www.toshiba-lifestyle.com/th

