

Nikon

DIGITAL CAMERA

COOLPIX W300

Reference Manual



Quick Topic Search

- Read this manual thoroughly before using the camera.
- To ensure proper use of the camera, be sure to read “For Your Safety” (page vi) and “<Important> Notes About Shockproof, Waterproof, and Dustproof Performance and Condensation” (page ix).
- After reading this manual, keep it in a readily accessible place for future reference.

En

Quick Topic Search

You can return to this page by tapping or clicking  in the lower right of any page.

Main Topics

Introduction	iii
Table of Contents	xiii
Parts of the Camera	1
Getting Started.....	9
Basic Shooting and Playback Operations	17
Shooting Features.....	25
Playback Features.....	66
Movies	79
Using Location Data Functions	94
Connecting the Camera to a TV, Printer, or Computer	107
Using the Menu.....	119
Technical Notes.....	178

Common Topics



For Your Safety



Shockproof and
Waterproof



Selecting a
Shooting Mode



Action Control



Active Guide



Editing Images
(Still Images)



Troubleshooting



Index



Introduction

Read This First

Thank you for purchasing the Nikon COOLPIX W300 digital camera.

Symbols and Conventions Used in This Manual

- Tap or click  in the lower right of each page to display “Quick Topic Search” (iii).
- Symbols

Symbol	Description
	This icon marks cautions and information that should be read before using the camera.
	This icon marks notes and information that should be read before using the camera.
	This icon marks other pages containing relevant information.

- SD, SDHC, and SDXC memory cards are referred to as “memory cards” in this manual.
- The setting at the time of purchase is referred to as the “default setting.”
- The names of menu items displayed on the camera screen, and the names of buttons or messages displayed on a computer screen appear in bold.
- In this manual, images are sometimes omitted from screen display samples so that screen indicators can be more clearly shown.



Information and Precautions

Life-Long Learning

As part of Nikon's "Life-Long Learning" commitment to ongoing product support and education, continually updated information is available online at the following websites:

- For users in the U.S.A.: <http://www.nikonusa.com/>
- For users in Europe: <http://www.europe-nikon.com/support/>
- For users in Asia, Oceania, the Middle East, and Africa: <http://www.nikon-asia.com/>

Visit these websites to keep up-to-date with the latest product information, tips, answers to frequently asked questions (FAQs), and general advice on digital imaging and photography. Additional information may be available from the Nikon representative in your area. Visit the website below for contact information.

<http://imaging.nikon.com/>

Use Only Nikon Brand Electronic Accessories

Nikon COOLPIX cameras are designed to the highest standards and include complex electronic circuitry. Only Nikon brand electronic accessories (including battery chargers, batteries, Charging AC Adapters, AC adapters and, USB cables) certified by Nikon specifically for use with this Nikon digital camera are engineered and proven to operate within the operational and safety requirements of this electronic circuitry.

THE USE OF NON-NIKON ELECTRONIC ACCESSORIES COULD DAMAGE THE CAMERA AND MAY VOID YOUR NIKON WARRANTY.

The use of third-party rechargeable Li-ion batteries not bearing the Nikon holographic seal could interfere with normal operation of the camera or result in the batteries overheating, igniting, rupturing, or leaking.

Holographic seal: Identifies this device as an authentic Nikon product.



For more information about Nikon brand accessories, contact a local authorized Nikon dealer.

Before Taking Important Pictures

Before taking pictures on important occasions (such as at weddings or before taking the camera on a trip), take a test shot to ensure that the camera is functioning normally. Nikon will not be held liable for damages or lost profits that may result from product malfunction.



About the Manuals

- No part of the manuals included with this product may be reproduced, transmitted, transcribed, stored in a retrieval system, or translated into any language in any form, by any means, without Nikon's prior written permission.
- Illustrations and screen content shown in this manual may differ from the actual product.
- Nikon reserves the right to change the specifications of the hardware and software described in these manuals at any time and without prior notice.
- Nikon will not be held liable for any damages resulting from the use of this product.
- While every effort was made to ensure that the information in these manuals is accurate and complete, we would appreciate it were you to bring any errors or omissions to the attention of the Nikon representative in your area (address provided separately).

Comply with Copyright Notices

Under copyright law, photographs or recordings of copyrighted works made with the camera can not be used without the permission of the copyright holder. Exceptions apply to personal use, but note that even personal use may be restricted in the case of photographs or recordings of exhibits or live performances.

Disposing of Data Storage Devices

Please note that deleting images or formatting data storage devices such as memory cards or built-in camera memory does not completely erase the original image data. Deleted files can sometimes be recovered from discarded storage devices using commercially available software, potentially resulting in the malicious use of personal image data. Ensuring the privacy of such data is the user's responsibility.

Before discarding a data storage device or transferring ownership to another person, make sure to reset all of the camera's settings in **Reset all** in the setup menu (📖120). After resetting, erase all data in the device using commercial deletion software, or format the device in **Format memory** or **Format card** in the setup menu (📖120), then completely refill it with images containing no private information (for example, images of empty sky).

Care should be taken to avoid injury or damage to property when physically destroying memory cards.

For the COOLPIX W300, the log data saved on the memory card is handled in the same way as other data. To erase the log data that is obtained but not stored on the memory card, select **Create log** → **End all logs** → **Erase logs**.

Conformity Marking

Follow the procedure below to display some of the conformity markings that the camera complies with.

Press the **MENU** button → **Y** menu icon → Conformity marking → **OK** button



For Your Safety

To prevent damage to property or injury to yourself or to others, read "For Your Safety" in its entirety before using this product.

Keep these safety instructions where all those who use this product will read them.



DANGER

Failure to observe the precautions marked with this icon carries a high risk of death or severe injury.



WARNING

Failure to observe the precautions marked with this icon could result in death or severe injury.



CAUTION

Failure to observe the precautions marked with this icon could result in injury or property damage.



WARNING

- **Do not use while walking or operating a vehicle.** Failure to observe this precaution could result in accidents or other injury.
- **Do not disassemble or modify this product. Do not touch internal parts that become exposed as the result of a fall or other accident.** Failure to observe these precautions could result in electric shock or other injury.
- **Should you notice any abnormalities such as the product producing smoke, heat, or unusual odors, immediately disconnect the battery or power source.** Continued operation could result in fire, burns or other injury.
- **Do not handle the plug with wet hands.** Failure to observe this precaution could result in fire or electric shock.
- **Do not let your skin remain in prolonged contact with this product while it is on or plugged in.** Failure to observe this precaution could result in low-temperature burns.
- **Do not use this product in the presence of flammable dust or gas such as propane, gasoline or aerosols.** Failure to observe this precaution could result in explosion or fire.
- **Do not aim the flash, AF-assist illuminator, LED light, or movie light at the operator of a motor vehicle.** Failure to observe this precaution could result in accidents.



- **Keep this product out of reach of children.** Failure to observe this precaution could result in injury or product malfunction. In addition, note that small parts constitute a choking hazard. Should a child swallow any part of this product, seek immediate medical attention.
- **Do not entangle, wrap or twist the straps around your neck.** Failure to observe this precaution could result in accidents.
- **Do not use batteries, chargers, AC adapters, or USB cables not specifically designated for use with this product. When using batteries, chargers, AC adapters, and USB cables designated for use with this product, do not:**
 - **Damage, modify, forcibly tug or bend the cords or cables, place them under heavy objects, or expose them to heat or flame.**
 - **Use travel converters or adapters designed to convert from one voltage to another or with DC-to-AC inverters.**Failure to observe these precautions could result in fire or electric shock.
- **Do not handle the plug when charging the product or using the AC adapter during thunderstorms.** Failure to observe this precaution could result in electric shock.
- **Do not handle with bare hands in locations exposed to extremely high or low temperatures.** Failure to observe this precaution could result in burns or frostbite.



CAUTION

- **Do not leave the lens pointed at the sun or other strong light sources.** Light focused by the lens could cause fire or damage to product's internal parts. When shooting backlit subjects, keep the sun well out of the frame.
- **Turn this product off when its use is prohibited. Disable the record location data functions. End log recording. Disable wireless features when the use of wireless equipment is prohibited.** The radio-frequency emissions produced by this product could interfere with equipment onboard aircraft or in hospitals or other medical facilities.
- **Remove the battery and disconnect the AC adapter if this product will not be used for an extended period.** Failure to observe this precaution could result in fire or product malfunction.
- **Do not fire the flash in contact with or in close proximity to the skin or objects.** Failure to observe this precaution could result in burns or fire.
- **Do not look directly into the AF-assist illuminator, LED light, or movie light.** This could damage the eyes or result in visual impairment.



- **Do not leave the product where it will be exposed to extremely high temperatures, for an extended period such as in an enclosed automobile or in direct sunlight.** Failure to observe this precaution could result in fire or product malfunction.
-



DANGER for Batteries

- **Do not mishandle batteries.** Failure to observe the following precautions could result in the batteries leaking, overheating, rupturing, or catching fire:
 - Use only rechargeable batteries approved for use in this product.
 - Do not expose batteries to flame or excessive heat.
 - Do not disassemble.
 - Do not short-circuit the terminals by touching them to necklaces, hairpins, or other metal objects.
 - Do not expose batteries or the products in which they are inserted to powerful physical shocks.
 - **Recharge batteries using the specified method.** Failure to observe this precaution could result in the batteries leaking, overheating, rupturing, or catching fire.
 - **If battery liquid comes into contact with the eyes, rinse with plenty of clean water and seek immediate medical attention.** Delaying action could result in eye injuries.
-



WARNING for Batteries

- **Keep batteries out of reach of children.** Should a child swallow a battery, seek immediate medical attention.
 - **Do not immerse this product in water or expose to rain.** Failure to observe this precaution could result in fire or product malfunction. Immediately dry the product with a towel or similar object should it become wet.
 - **Discontinue use immediately should you notice any changes in the battery, such as discoloration or deformation. Cease charging if they do not charge in the specified period of time.** Failure to observe these precautions could result in the battery leaking, overheating, rupturing, or catching fire.
 - **Prior to disposal, insulate battery terminals with tape.** Overheating, rupture, or fire may result should metal objects come into contact with the terminals. Recycle or dispose of batteries in accord with local regulations.
 - **If battery liquid comes into contact with a person's skin or clothing, immediately rinse the affected area with plenty of clean water.** Failure to observe this precaution could result in skin irritation.
-



<Important> Notes About Shockproof, Waterproof, and Dustproof Performance and Condensation

- The shockproof, waterproof, and dustproof performance described here do not guarantee that the camera will remain completely waterproof or free from damage and trouble under all conditions.
- Do not subject the camera to excessive shock, vibration or pressure by dropping it, hitting it, or placing a heavy object on it. Failure to observe this precaution could deform the camera, cause water to seep inside, or damage the airtight seals, resulting in camera malfunction.
- Your Nikon warranty may not cover troubles caused by water seeping inside the camera due to improper handling of the camera.

Notes About Shockproof Performance

This camera has passed Nikon's in-house test (drop test from a height of 240 cm (7 ft 10 in.) on a 5 cm (2 in.) thick plywood panel) compliant with the MIL-STD 810F Method 516.5-Shock* standard.

Changes in appearance, such as paint peeling off and deformation of the camera, are not measured in Nikon's in-house test.

* U.S. Department of Defense test method standard.

This test is defined by preparing 5 cameras and making sure that the test is passed within 5 cameras by dropping in 26 directions (8 corners, 12 edges, and 6 faces) from a height of 122 cm (4 ft).

Notes About Waterproof and Dustproof Performance

The camera is rated equivalent to JIS/IEC waterproof class 8 (IPX8) and JIS/IEC dustproof class 6 (IP6X) and can shoot images underwater at a depth of 30 m (100 ft) for up to 60 minutes.*

* This rating indicates that the camera has been designed to withstand the specified water pressure for the specified period of time when the camera is used according to the methods defined by Nikon.

- The waterproof performance of this camera was tested in fresh water (swimming pools, rivers, and lakes) and salt water only.
- The inner portion of this camera is not waterproof. Water seeping inside the camera could cause the components to rust, resulting in high repair costs or irreparable damage.
- Accessories are not waterproof.

Precautions When Cleaning

- Do not puncture the microphone or speaker openings with a sharp implement. If the inside of the camera is damaged, the waterproof performance will deteriorate.
- Do not use soap, neutral detergents, or chemicals such as benzene for cleaning.



Notes About Shockproof, Waterproof, and Dustproof Performance

- Do not drop the camera, strike it against a hard object such as a rock, or throw it against a water surface.
- Do not subject the camera to shock when using it underwater.
 - Do not subject the camera to water pressure by exposing it to rapids or waterfalls.
 - Do not expose to depths greater than 30 m (100 ft) underwater.
 - Make sure not to drop the camera underwater. This camera does not float in water.
- Do not continuously use the camera underwater for 60 minutes or more.
- Do not insert a wet memory card or battery in the camera.
 - Do not open the battery-chamber/memory card slot cover when the camera or your hands are wet. Doing so may cause water to seep inside the camera or result in camera malfunction.
- Do not open the battery-chamber/memory card slot cover underwater.
- If moisture such as water droplets adheres to the outside of the camera or inside of the battery-chamber/memory card slot cover, immediately wipe it off with a soft dry cloth.
 - If a foreign substance adheres to the outside of the camera or inside of the battery-chamber/memory card slot cover, immediately remove it with a blower or a soft cloth.
 - If a foreign substance adheres to the waterproof packing inside the battery-chamber/memory card slot cover, remove it with the included brush. Do not use the included brush for anything other than cleaning the waterproof packing.
- Do not leave the camera in cold conditions or in hot conditions of 40°C (104°F) or more for a long period of time.
 - Doing so could cause deterioration of the waterproof performance.
 - When using the camera underwater, make sure the water temperature is from 0°C to 40°C (32°F to 104°F).
- Do not use the camera at hot springs.

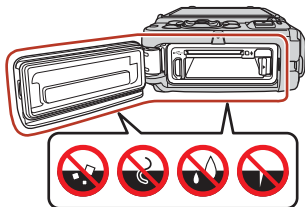

Waterproof packing

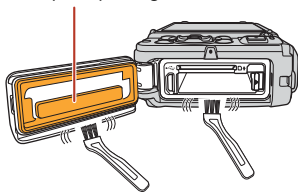

Before Using the Camera Underwater

Check the items below before using the camera underwater.

- Remove the camera strap for land use.
- Make sure that there are no foreign substances inside the battery-chamber/memory card slot cover.
- Make sure that the waterproof packing of the battery-chamber/memory card slot cover is not cracked or deformed.
 - Make sure that the waterproof packing is not detached from the camera.
- Make sure that the battery-chamber/memory card slot cover is firmly closed.
 - Make sure that the latch indicator indicates the "Close" status.

Notes About Operating Temperature, Humidity, and Condensation

The operation of this camera has been tested at temperatures from -10°C to $+40^{\circ}\text{C}$ (14°F to 104°F).

When you use the camera in cold climate regions or at high altitudes, observe the following precautions.

- Battery performance deteriorates temporarily when cold. Keep the camera and batteries warm under your clothing before use.
- Camera performance may deteriorate temporarily if it is exposed to extreme cold for an extended period. For example, the monitor may appear darker than normal immediately after the camera is turned on, or residual images may be produced.

● Environmental conditions that are likely to cause condensation

Fogging (condensation) may occur on the inside of the monitor or lens when there are sharp temperature changes or high humidity, such as in the environmental conditions described below. This is not a camera malfunction or defect.

- The camera is suddenly immersed in cold water after being in a hot place on land.
- The camera is brought to a warm place such as inside a building after being in the cold outdoors.
- The battery-chamber/memory card slot cover is opened or closed in a high-humidity environment.

● Reducing condensation

- Open the battery-chamber/memory card slot cover, put the camera and a commercially-available desiccant in a container such as a plastic bag, and seal the container. Condensation is less likely to occur if the humidity inside the camera is reduced.
- Before using the camera underwater, avoid storing it in locations where the camera may become hot (such as under direct sunlight).

If you submerge the camera underwater while it is hot, the sudden change in temperature may cause condensation.



● **Clearing the fogging**

- Turn off the camera and open the battery-chamber/memory card slot cover while in a place where the ambient temperature is stable (avoid places with high temperature, high humidity, sand, or dust).

To clear the fogging, remove the battery and memory card, and leave the battery-chamber/memory card slot cover open to allow the camera to adjust to the ambient temperature.

Inspection and Repair

- If the camera is exposed to shock, it is recommended to consult your retailer or Nikon-authorized service representative to confirm the waterproof performance (charged service).
- If the waterproof packing begins to deteriorate, consult your retailer or Nikon-authorized service representative. The waterproof performance of the waterproof packing may start to deteriorate after one year.
- If water seeps inside the camera, immediately stop using it and take it to your Nikon-authorized service representative.



Table of Contents

Quick Topic Search	ii
Main Topics.....	ii
Common Topics	ii
<hr/>	
Introduction	iii
Read This First	iii
Symbols and Conventions Used in This Manual	iii
Information and Precautions.....	iv
For Your Safety	vi
<Important> Notes About Shockproof, Waterproof, and Dustproof Performance and Condensation.....	ix
Notes About Shockproof Performance.....	ix
Notes About Waterproof and Dustproof Performance.....	ix
Notes About Shockproof, Waterproof, and Dustproof Performance	x
Before Using the Camera Underwater.....	xi
Notes About Operating Temperature, Humidity, and Condensation.....	xi
Inspection and Repair.....	xii
<hr/>	
Parts of the Camera	1
The Camera Body.....	2
The Monitor	4
For Shooting.....	4
For Playback.....	7
For the Active Guide	8
<hr/>	
Getting Started.....	9
How to Attach the Camera Strap for Land Use.....	10
Inserting the Battery and Memory Card.....	11
Removing the Battery or Memory Card.....	12
Charging the Battery	13
Camera Setup.....	15



Basic Shooting and Playback Operations	17
Shooting Images	18
Recording Movies	20
Using the LED Light	20
Playing Back Images	21
Deleting Images	22
The Image Selection Screen for Deletion	23
Action Control	24
Displaying the Previous or Next Image in Full-frame Playback Mode	24
Using Action Menu	24
<hr/>	
Shooting Features	25
Selecting a Shooting Mode	26
SCN (Scene Auto Selector) Mode	28
Scene Mode (Shooting Suited to the Shooting Conditions)	30
Tips and Notes About Scene Mode	31
Shooting with Easy Panorama	37
Playback with Easy Panorama	39
Creative Mode (Applying Effects When Shooting)	40
Smart Portrait Mode (Enhancing Human Faces When Shooting)	42
Using Smile Timer	44
Using Self-Collage	45
📷 (Auto) Mode	47
Using the Creative Slider	47
Setting Shooting Functions with the Multi Selector	49
Flash Mode	50
Self-timer	52
Macro Mode (Taking Close-up Pictures)	54
Exposure Compensation (Adjusting Brightness)	55
Using the Zoom	56
Focusing	57
The Shutter-release Button	57
Using Face Detection	58
Using Target Finding AF	59
Subjects Not Suitable for Autofocus	60
Focus Lock	61
Default Settings (Flash, Self-timer, and Macro Mode)	62
Functions That Cannot Be Used Simultaneously When Shooting	64



Playback Features	66
Playback Zoom	67
Thumbnail Playback/Calendar Display	68
List by Date Mode.....	69
Viewing and Deleting Images in a Sequence	70
Viewing Images in a Sequence.....	70
Deleting Images in a Sequence	71
Editing Images (Still Images)	72
Before Editing Images	72
Quick Effects: Changing Hue or Mood	72
Quick Retouch: Enhancing Contrast and Saturation	73
D-Lighting: Enhancing Brightness and Contrast.....	74
Red-eye Correction: Correcting Red-eye When Shooting with the Flash	74
Glamour Retouch: Enhancing Human Faces.....	75
Data Imprint: Imprinting Information Such as Electronic Compass Heading on Images.....	76
Small Picture: Reducing the Size of an Image	77
Crop: Creating a Cropped Copy.....	78
<hr/>	
Movies	79
Basic Operations of Movie Recording and Movie Playback	80
Capturing Still Images While Recording Movies	84
Shooting Time-lapse Movies	85
Recording Superlapse Movies.....	87
Short Movie Show Mode (Combining Movie Clips to Create Short Movies)	88
Using Special Effects.....	90
Operations During Movie Playback	91
Editing Movies	92
Extracting Only the Desired Portion of a Movie.....	92
Saving a Frame from a Movie as a Still Image	93
<hr/>	
Using Location Data Functions	94
Operations Available with Location Data Functions	95
Recording the Location Data on the Image.....	97
Updating the A-GPS File	99
Using Altimeter and Depth Gauge.....	100
Recording the Log of Movement Information.....	101
Starting Log Recording.....	101
Ending Log Recording and Saving Logs on a Memory Card.....	103
Displaying Altitude/Depth Logs as a Graph	104
Displaying the Active Guide	105



Connecting the Camera to a TV, Printer, or Computer	107
Utilizing Images.....	108
Viewing Images on a TV.....	110
Printing Images Without a Computer	111
Connecting the Camera to a Printer.....	111
Printing Images One at a Time.....	112
Printing Multiple Images.....	113
Transferring Images to a Computer (NX Studio)	115
Installing NX Studio.....	115
Copying Pictures to a Computer Using NX Studio.....	116
Using the Menu	119
Menu Operations	120
The Image Selection Screen.....	122
Menu Lists	123
The Shooting Menu.....	123
The Movie Menu.....	124
The Playback Menu.....	125
The Network Menu.....	125
The Location Data Options Menu.....	126
The Setup Menu.....	127
The Shooting Menu (The Common Shooting Options)	128
Image Mode (Image Size and Quality).....	128
The Shooting Menu (for  (Auto) Mode)	130
White Balance (Adjusting Hue).....	130
Continuous Shooting.....	132
ISO Sensitivity.....	134
AF Area Mode.....	135
Autofocus Mode.....	138
The Smart Portrait Menu	139
Self-Collage.....	139
Blink Proof.....	140
The Movie Menu	141
Movie Options.....	141
AF Area Mode.....	145
Autofocus Mode.....	146
Movie VR.....	147
Movie Light.....	147
Wind Noise Reduction.....	148
Frame Rate.....	148



The Playback Menu	149
Mark for Upload.....	149
Slide Show.....	150
Protect.....	151
Rotate Image.....	151
Copy (Copy Between the Memory Card and Internal Memory).....	152
Sequence Display.....	153
The Network Menu	154
Operating the Text Input Keyboard.....	156
The Location Data Options Menu	157
Location Data Options.....	157
Points of Interest (POI) (Recording and Displaying Location Name Information).....	158
Create Log.....	159
View Log.....	160
Set Clock from Satellite.....	160
Electronic Compass.....	161
Altitude/Depth Options.....	162
The Setup Menu	163
Time Zone and Date.....	163
Monitor Settings.....	165
Date Stamp.....	167
Photo VR.....	168
AF Assist.....	169
Digital Zoom.....	169
Sound Settings.....	170
Underwater Flash.....	170
Action Control Response.....	171
Playback Action Control.....	171
Auto Off.....	172
LED Light Timer.....	172
Format Card/Format Memory.....	173
Language.....	173
Image Comment.....	174
Copyright Information.....	175
Charge by Computer.....	176
Reset All.....	177
Conformity Marking.....	177
Firmware Version.....	177



Technical Notes.....	178
Notices.....	179
Notes About Wireless Communication Functions	181
Notes About Location Data Functions (GPS/GLONASS, Electronic Compass)	184
Caring for the Product	185
The Camera.....	185
The Battery	186
The Charging AC Adapter.....	187
Memory Cards.....	188
Cleaning and Storage.....	189
Cleaning After Using the Camera Underwater.....	189
Cleaning After Using the Camera in Conditions Other than Underwater.....	189
Storage.....	190
Error Messages.....	191
Troubleshooting	195
File Names	206
Optional Accessories	208
Attaching the Underwater Speedlight	209
Specifications	213
Memory Cards That Can Be Used.....	218
USER LICENSE AGREEMENT FOR LOCATION NAME DATA	220
Index.....	225



Parts of the Camera

The Camera Body	2
The Monitor	4



The Camera Body

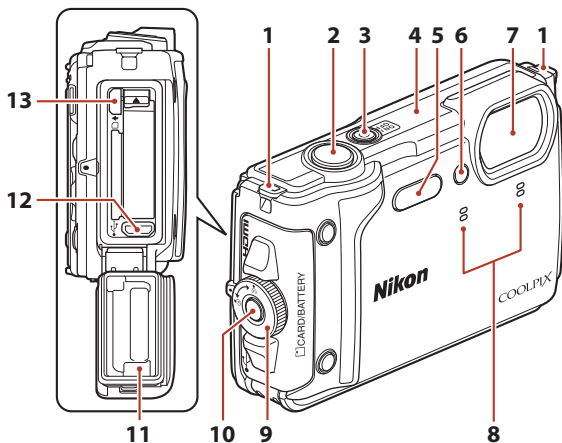

1	Eyelet for camera strap	10	8	Microphone (stereo)
2	Shutter-release button.....	19	9	Battery-chamber/memory card slot cover latch.....
3	Power switch/power-on lamp.....	15	10	Battery-chamber/memory card slot cover latch release.....
4	Positioning antenna	98	11	Waterproofing packing
5	Flash.....	50	12	Micro-USB connector
	LED light.....	20	13	HDMI micro connector (Type D).....
6	Self-timer lamp	52		
	AF-assist illuminator			
	Movie light.....	147		
7	Lens			



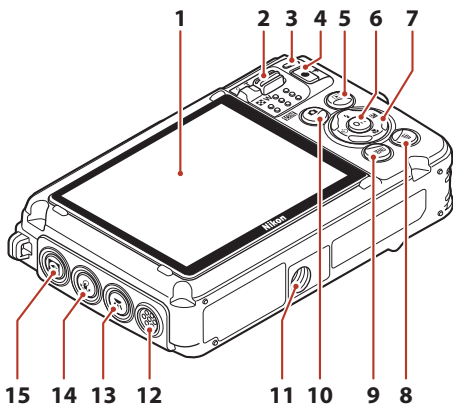

1	Monitor.....	4	7	Multi selector*.....	120
	Zoom control.....	56	8	(delete) button.....	22
	W : Wide-angle.....	56	9	MENU (menu) button.....	120
2	T : Telephoto.....	56	10	(shooting mode) button	
	: Thumbnail playback.....	68		26, 28, 30, 40, 42, 47, 88
	: Playback zoom.....	67	11	Tripod socket	
3	Charge lamp.....	13	12	Speaker	
	Flash lamp.....	50	13	(LED light) button.....	20
4	(movie-record) button.....	80	14	(action) button.....	24
5	(playback) button.....	21	15	(tool) button.....	105
6	(apply selection) button.....	120			

* In this manual, pressing up, down, left, or right on the multi selector is expressed as ▲, ▼, ◀, or ▶.



The Monitor

The information that is displayed on the shooting or playback screen changes depending on the camera's settings and state of use.

By default, information is displayed when the camera is turned on and when you operate the camera, and turns off after a few seconds (when **Photo info** is set to **Auto info** in **Monitor settings** (📖165)).

For Shooting

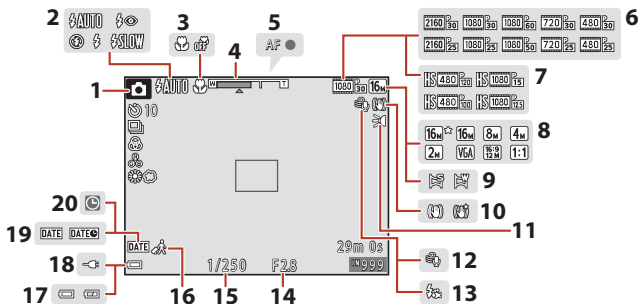

1 Shooting mode 26, 28, 30, 40, 42, 47, 88	11 LED light on 20
2 Flash mode 50	12 Wind noise reduction 148
3 Macro mode 54	13 Underwater flash 170
4 Zoom indicator 54, 56	14 F-number 57
5 Focus indicator 19	15 Shutter speed 57
6 Movie options (normal speed movies) 141	16 Travel destination icon 163
7 Movie options (HS movies) 142	17 Battery level indicator 19
8 Image mode 128	18 Charging AC adapter connection indicator
9 Easy panorama 37	19 Date stamp 167
10 Vibration reduction icon 147, 168	20 "Date not set" indicator 196



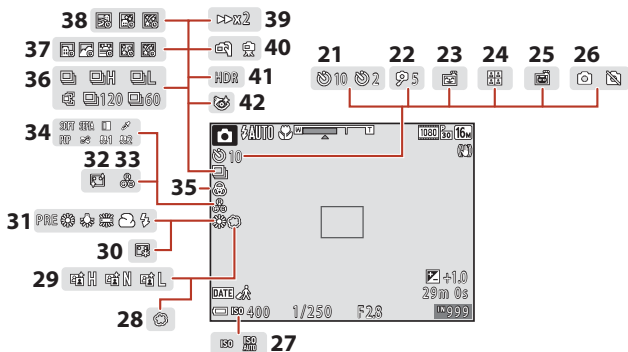

21 Self-timer indicator.....	52	32 Skin softening.....	42
22 Self-portrait timer.....	52	33 Hue.....	47
23 Smile timer	44	34 Special effects.....	90
24 Self-Collage	45, 139	35 Vividness.....	42, 47
25 Pet portrait auto release.....	34	36 Continuous shooting mode.....	34, 132
26 Still image capture (during movie recording).....	84	37 Time-lapse movie.....	85
27 ISO sensitivity.....	134	38 Multiple exp. Lighten.....	35
28 Soft.....	42	39 Playback speed.....	87
29 Active D-Lighting	47	40 Hand-held/tripod.....	31, 32
30 Foundation makeup.....	42	41 Backlighting (HDR)	33
31 White balance.....	130	42 Blink proof icon	140



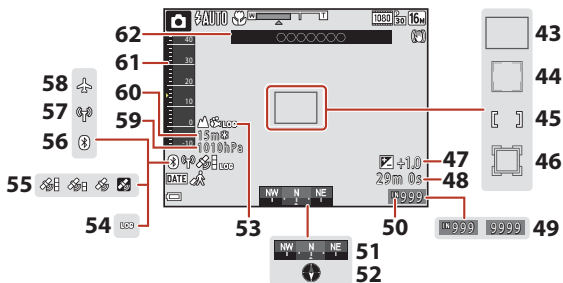

43	Focus area (target finding AF) ...59, 136	53	Log display (altitude/water depth)101
44	Focus area (face detection, pet detection).....34, 44, 58, 135	54	Log display (location data).....101
45	Focus area (manual, center)61, 135	55	Location data reception 95
46	Focus area (subject tracking) 136, 137	56	Bluetooth communication indicator*155
47	Exposure compensation value42, 47, 55	57	Wi-Fi communication indicator 154
48	Remaining movie recording time 80, 81	58	Airplane mode154
49	Number of exposures remaining (still images)..... 19	59	Atmospheric pressure100
50	Internal memory indicator..... 19	60	Altitude/water depth.....100
51	Compass display (direction gauge) 161	61	Altimeter/depth gauge100
52	Compass display (compass) 161	62	Location name information (POI information).....158

* On: A smart device is connected through Bluetooth.
 Flashing: Waiting to reconnect with a smart device. It also flashes when Bluetooth communication is disconnected while uploading images (📖204).



For Playback

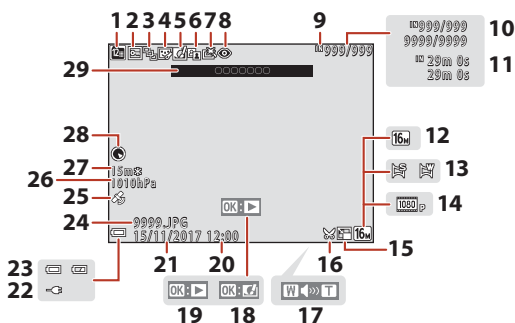

1	List by date icon	69	16	Crop icon	67, 78
2	Protect icon	151	17	Volume indicator	91
3	Sequence display (when Individual pictures is selected)	153	18	Quick effects guide	
4	Glamour retouch icon	75		Easy panorama playback guide	
5	Quick effects icon	72	19	Sequence playback guide	
6	D-Lighting icon	74		Movie playback guide	
7	Quick retouch icon	73	20	Time of recording	
8	Red-eye correction icon	74	21	Date of recording	
9	Internal memory indicator		22	Charging AC adapter connection indicator	
10	Current image number/ total number of images		23	Battery level indicator	19
11	Movie length or elapsed playback time		24	File number and type	206
12	Image mode	128	25	Recorded location data indicator	97
13	Easy panorama	39	26	Atmospheric pressure	100
14	Movie options	141	27	Altitude/water depth	100
15	Small picture icon	77	28	Compass display (compass)	95, 161
			29	Location name information (POI information)	158



For the Active Guide

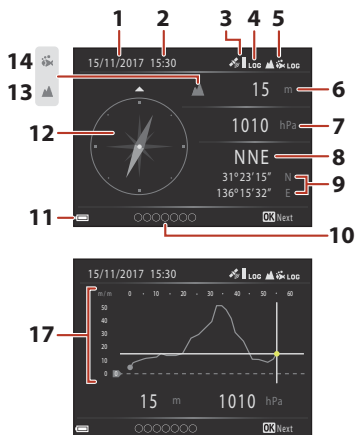

- | | | |
|-----------|---|-----|
| 1 | Date | |
| 2 | Time | |
| 3 | Location data reception..... | 95 |
| 4 | Log display (location data)..... | 101 |
| 5 | Log display (altitude or water depth)
..... | 101 |
| 6 | Altitude or water depth | |
| 7 | Atmospheric pressure | |
| 8 | Direction | |
| 9 | Latitude and longitude | |
| 10 | Location name information
(POI information)..... | 158 |
| 11 | Battery level indicator..... | 19 |
| 12 | Compass display | |
| 13 | Altitude icon | |
| 14 | Depth icon | |
| 15 | Altimeter | |
| 16 | Depth gauge | |
| 17 | Altitude/depth logs graph* | |

* The horizontal axis of the graph shows the total time during log recording, and the vertical axis of the graph shows the total variations in altitude/depth during log recording. The graph updates automatically in 1-second intervals.



Getting Started

How to Attach the Camera Strap for Land Use.....	10
Inserting the Battery and Memory Card.....	11
Charging the Battery.....	13
Camera Setup.....	15



How to Attach the Camera Strap for Land Use

Remove the strap for land use before using the camera underwater.

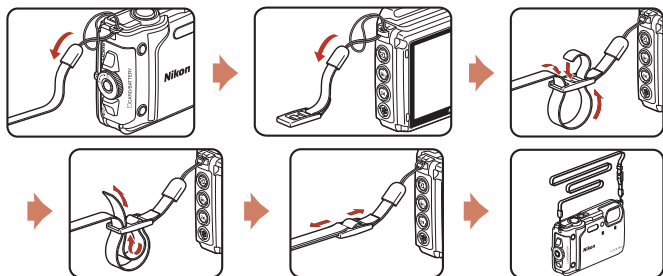

Inserting the Battery and Memory Card

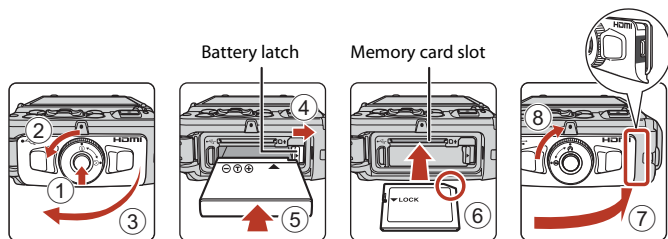

- Press the battery-chamber/memory card slot cover latch release (1) and rotate the battery-chamber/memory card slot cover latch (2) to open the cover (3).
- With the battery's positive and negative terminals oriented correctly, move the orange battery latch (4), and fully insert the battery (5).
- Slide the memory card in until it clicks into place (6).
- Be careful not to insert the battery or memory card upside-down or backward, as this could cause a malfunction.
- Close the battery-chamber/memory card slot cover (7) and, while pressing it firmly against the camera so that the red portion on the side of the cover is hidden, rotate the battery-chamber/memory card slot cover latch until it clicks into place (8).

Make sure that the cover is securely locked.

- If the write-protect switch of the memory card is locked, you cannot shoot, delete images, or format the memory card.
- Camera data, including images and movies, can be saved either on a memory card or in the internal memory. To use the internal memory, remove the memory card.

✓ Notes About Waterproof and Dustproof Performance

See "Notes About Shockproof, Waterproof, and Dustproof Performance" (📖x) for more information.

✓ Notes About Closing the Cover without Getting the Camera Strap's Cord Caught

If the camera strap's cord gets caught in the battery-chamber/memory card slot cover when it is closed, the cover could be damaged. Before closing the battery-chamber/memory card slot cover, make sure that the cord does not get caught in it.



Formatting a Memory Card

The first time you insert a memory card that has been used in another device into this camera, make sure to format it with this camera.

- **Note that formatting a memory card permanently deletes all images and other data on the memory card.** Be sure to make copies of any images you wish to keep before formatting the memory card.
- Insert the memory card into the camera, press the **MENU** button, and select **Format card** in the setup menu (120).

Removing the Battery or Memory Card

Turn the camera off and make sure that the power-on lamp and screen have turned off, and then open the battery-chamber/memory card slot cover.

- Move the battery latch to eject the battery.
- Gently push the memory card into the camera to partially eject the memory card.
- Be careful when handling the camera, battery, and memory card immediately after using the camera, as they may be hot.



Charging the Battery

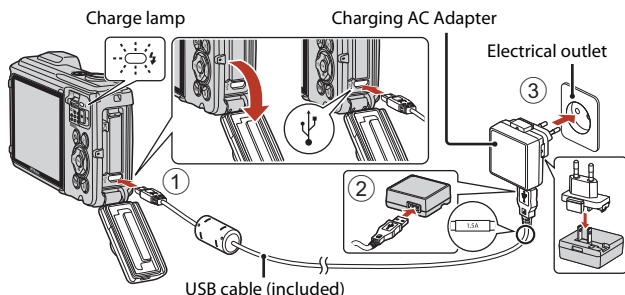

If a plug adapter* is included with your camera, securely connect it to the Charging AC Adapter. Once the two are connected, attempting to forcibly remove the plug adapter could damage the product.

* The shape of the plug adapter varies according to the country or region in which the camera was purchased.

This step can be omitted if the plug adapter comes permanently bonded to the Charging AC Adapter.

- Charging starts when the camera is connected to an electrical outlet while the battery is inserted, as shown in the illustration. The charge lamp slowly flashes while the battery is charging.
- When charging is complete, the charge lamp turns off. Unplug the Charging AC Adapter from the electrical outlet, and disconnect the USB cable. Charging time is about 2 hours and 20 minutes for a fully exhausted battery.
- The battery cannot be charged when the charge lamp quickly flashes, possibly due to one of the reasons described below.
 - The ambient temperature is not suited to charging.
 - The USB cable or Charging AC Adapter is not properly connected.
 - The battery is damaged.



Notes About the USB Cable

- Do not use a USB cable other than the UC-E21. Using a USB cable other than the UC-E21 could result in overheating, fire or electric shock.
- Check the shape and direction of the plugs and do not insert or remove the plugs at an angle.

Notes About Charging the Battery

- The camera can be operated while the battery is charging, but the charging time increases.
- If the battery level is extremely low, you may not be able to operate the camera while the battery is charging.
- Do not, under any circumstances, use another make or model of AC adapter other than the EH-73P/EH-73PCH Charging AC Adapter, and do not use a commercially available USB-AC adapter or a battery charger for a mobile phone. Failure to observe this precaution could result in overheating or in damage to the camera.



Camera Setup

1 Press the power switch to turn on the camera.

- Use the multi selector to select and adjust settings.

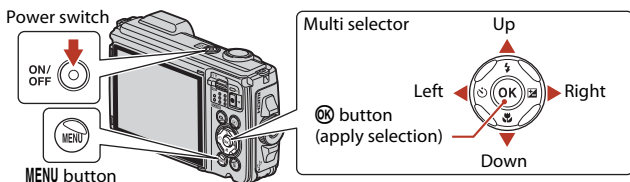

- A language selection screen will be displayed. Use the multi selector ▲▼ to highlight a language and press the OK button to select.
- The language can be changed at any time in the setup menu (📖 120) → **Language**.

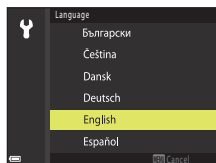

2 When the dialog on the right is displayed, follow the instructions below and press the MENU button or the OK button.

- If you will not establish a wireless connection with a smart device:
Press the **MENU** button and proceed to step 3.
- If you will establish a wireless connection with a smart device:
Press the **OK** button. See the included "SnapBridge Connection Guide" for the setup procedure.
When you establish a wireless connection using the SnapBridge app, you can upload images captured with the camera to a smart device or perform remote photography.

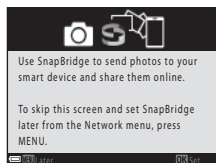

3 Use ▲▼ to select **Yes** when prompted to set the camera clock, and then press the OK button.



4 Highlight your home time zone and press the **OK** button.

- You can set daylight saving time by pressing ▲. When it is turned on, the clock is set one hour faster and ☀️ is displayed above the map. Press ▼ to turn it off.

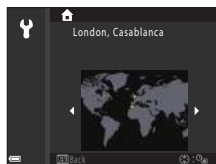

5 Use ▲▼ to select the date format and press the **OK** button.

6 Enter the current date and time and press the **OK** button.

- Use ◀▶ to highlight items and ▲▼ to change.
- Select the minute field and press the **OK** button to confirm the setting.

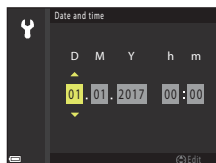

7 When the confirmation dialog is displayed, select **Yes** and press the **OK** button.

- You can change the time zone, date, and time using the setup menu (📖120) → **Time zone and date**.

8 Read the message about the waterproof function, and press ▶.

- Confirm the last message and press the **OK** button. The camera switches to the shooting screen when setup is complete.
- Waterproofing-related messages are displayed in the following situations.
 - When turning on and setting the camera for the first time after purchase
 - When setting the camera to **Underwater** scene mode
 - When turning the camera on after charging



Basic Shooting and Playback Operations

Shooting Images.....	18
Playing Back Images.....	21
Deleting Images.....	22
Action Control	24



Shooting Images

SCENE (scene auto selector) mode is used here as an example. In **SCENE** (scene auto selector) mode, the camera recognizes the shooting conditions when you frame a picture, and you can take pictures in accordance with the conditions.

1 Hold the camera steady.

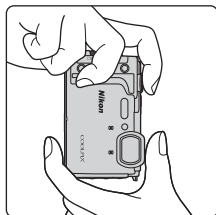
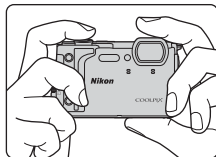

- Keep fingers and other objects away from the lens, flash, AF-assist illuminator, microphone, and speaker.
- When taking pictures in portrait (“tall”) orientation, turn the camera so that the flash is above the lens.

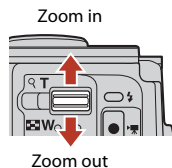

2 Frame the picture.

- Move the zoom control to change the zoom lens position.



- When the camera recognizes the shooting conditions, the shooting mode icon changes accordingly.
- Battery level indicator
 - : The battery level is high.
 - : The battery level is low.
- Number of exposures remaining
 -  is displayed when no memory card is inserted in the camera, and images are saved in the internal memory.

Shooting mode icon

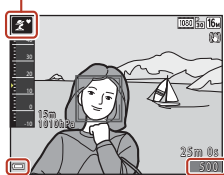

Battery level indicator

Number of exposures remaining

3 Press the shutter-release button halfway.

- To press the shutter-release button "halfway" means to press and hold the button at the point where you feel a slight resistance.
- When the subject is in focus, the focus area or focus indicator is displayed in green.
- When you are using digital zoom, the camera focuses in the center of the frame and the focus area is not displayed.
- If the focus area or focus indicator flashes, the camera is unable to focus. Modify the composition and try pressing the shutter-release button halfway again.

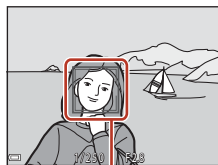
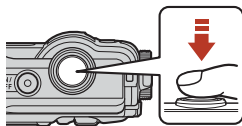

Focus area

4 Without lifting your finger, press the shutter-release button all the way down.



Notes About Saving Images or Movies

The indicator showing the number of exposures remaining or the indicator showing the remaining recording time flashes while images or movies are being saved. **Do not open the battery-chamber/memory card slot cover or remove the battery or memory card** while an indicator is flashing. Doing this could result in loss of data, or in damage to the camera or the memory card.





The Auto Off Function

- When no operations are performed for about one minute, the screen turns off, the camera enters standby mode, and then the power-on lamp flashes. The camera turns off after remaining in standby mode for about three minutes.
- To turn the screen back on while the camera is in standby mode, perform an operation such as pressing the power switch or shutter-release button.

When Using a Tripod

- We recommend using a tripod to stabilize the camera in the following situations:
 - When shooting in dim lighting with the flash mode (📖49) set to  (off)
 - When the zoom is at a telephoto position
- When using a tripod to stabilize the camera during shooting, set **Photo VR** to **Off** in the setup menu (📖120) to prevent potential errors caused by this function.

Recording Movies

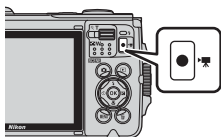

Display the shooting screen and press the  (📹 movie-record) button to start recording a movie. Press the  button again to end recording.

- If the battery temperature becomes low, the image size/frame rate of movies may be restricted. Warm up the battery with your palms, etc. before use.



Using the LED Light

Use the LED light in dark places, etc.

Press and hold down the  (LED light) button to turn on an LED light. To turn it off, press the  button.

You can also use the LED light when the camera is turned off.

- Use **LED light timer** in the setup menu (📖120) to set the amount of time that elapses before the LED light turns off.

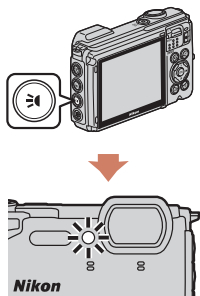





Playing Back Images

1 Press the (playback) button to enter playback mode.

- If you press and hold down the  button while the camera is turned off, the camera turns on in playback mode.





2 Use the multi selector to select an image to display.

- Press and hold down    to scroll through the images quickly.
- To play back a recorded movie, press the  button.
- To return to shooting mode, press the  button or shutter-release button.

Display the previous image



Display the next image

- When  is displayed in full-frame playback mode, you can press the  button to apply an effect to the image.



- Move the zoom control toward **T** () in full-frame playback mode to zoom in on an image.





- In full-frame playback mode, move the zoom control toward **W** () to switch to thumbnail playback mode and display multiple images on the screen.



Deleting Images

- 1 Press the  (delete) button to delete the image currently displayed on the screen.



- 2 Use the multi selector   to select the desired deletion method and press the  button.

- To exit without deleting, press the **MENU** button.

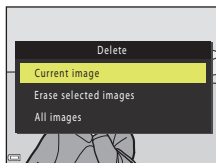

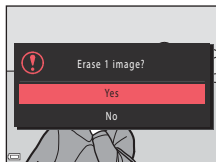

- 3 Select **Yes** and press the  button.

- Deleted images cannot be recovered.



Deleting Images Captured Continuously (Sequence)

- Images captured continuously, or with the multiple exp. lighten, creative mode, or self-collage function, are saved as a sequence, and only one image in the sequence (the key picture) is displayed in playback mode (default setting).
- If you press the  button while a key picture is displayed for a sequence of images, all images in the sequence are deleted.
- To delete individual images in a sequence, press the  button to display them one at a time and press the  button.



Deleting the Image Captured While in Shooting Mode

When using shooting mode, press the  button to delete the last image that was saved.



The Image Selection Screen for Deletion

1 Use the multi selector ◀▶ to select the image that you want to delete.

- Move the zoom control (📖) toward **T** (🔍) to switch to full-frame playback, or **W** (📄) to switch to thumbnail playback.

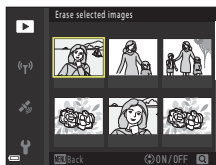

2 Use ▲▼ to select **ON** or **OFF**.

- When **ON** is selected, an icon is displayed under the selected image. Repeat steps 1 and 2 to select additional images.

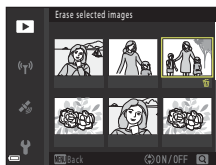

3 Press the **OK** button to apply the image selection.

- A confirmation dialog is displayed. Follow the on-screen instructions to operate.



Action Control

The operations described below can be performed by shaking the camera.

Displaying the Previous or Next Image in Full-frame Playback Mode

In full-frame playback mode, shake the camera up/down to display the next image, or forward/backward to display the previous image (when **Playback action control** in the setup menu (📖120) is set to **On**).

- Make sure to hold the camera firmly with the camera strap around your hand, and use your wrist to shake the camera as shown in the illustration.

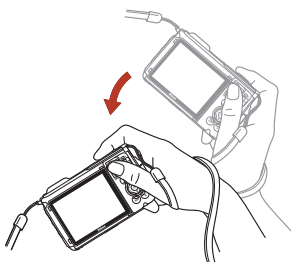



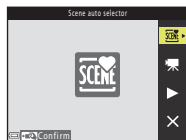
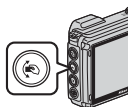

Using Action Menu

Press the  (action) button to display the action menu.

- Shake the camera to select an option listed below, and press the  button to perform the operation.





Action menu

Option	Description
Shooting mode selection	Select a shooting mode (only restricted to some shooting modes).
 Start movie recording	Press the  button to record/end a movie. The  (movie-record) button cannot be used to end recording.
 Quick playback	Display an image in full-frame playback mode. You can use action control to play back images.
 Exit	Exit the action menu.

While the action menu is displayed, only the  button, shutter-release button, power switch, or  (LED light) button can be used.



Shooting Features

Selecting a Shooting Mode	26
 (Scene Auto Selector) Mode	28
Scene Mode (Shooting Suited to the Shooting Conditions)	30
Creative Mode (Applying Effects When Shooting)	40
Smart Portrait Mode (Enhancing Human Faces When Shooting)	42
 (Auto) Mode	47
Setting Shooting Functions with the Multi Selector	49
Flash Mode	50
Self-timer	52
Macro Mode (Taking Close-up Pictures)	54
Exposure Compensation (Adjusting Brightness)	55
Using the Zoom	56
Focusing	57
Default Settings (Flash, Self-timer, and Macro Mode)	62
Functions That Cannot Be Used Simultaneously When Shooting	64





Selecting a Shooting Mode



The shooting modes described below are available.

- **SCN Scene auto selector**
The camera recognizes the shooting conditions when you frame a picture, and you can take pictures in accordance with those conditions.
- **Scene mode**
Select any one of scene modes based on the shooting conditions, and you can take pictures with the appropriate settings for those conditions.
- **CC Creative mode**
The camera saves four images with effects and one image without effects simultaneously in one shot.
- **Smart portrait**
Use glamour retouch to enhance human faces during shooting, and use the smile timer or self-collage function to take pictures.
- **Short movie show**
The camera creates a short movie that is up to 30 seconds long (**1080 P 30 1080/30p** or **1080 P 25 1080/25p**) by recording and automatically combining multiple movie clips that are several seconds long.
- **Auto mode**
Select this mode to perform general shooting in a variety of shooting conditions.

- 1 When the shooting screen is displayed, press the  (shooting mode) button.



- 2 Use the multi selector   to select a shooting mode and press the  button.

- When scene mode is selected, press  to select a scene mode or effect before pressing the  button.

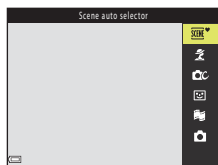

Help Display



The descriptions of functions are displayed while changing the shooting mode or while the setting screen is displayed.

You can show or hide the descriptions using **Help display** in **Monitor settings** in the setup menu.













(Scene Auto Selector) Mode

The camera recognizes the shooting conditions when you frame a picture, and you can take pictures in accordance with those conditions.



Enter shooting mode →  (shooting mode) button →  (scene auto selector) mode →  button

When the camera automatically recognizes the shooting conditions, the shooting mode icon displayed on the shooting screen changes accordingly.

	Portrait (for taking close-up portraits of one or two people)
	Portrait (for taking portraits of large numbers of people, or images in which the background takes up a large portion of the frame)
	Landscape
	Night portrait (for taking close-up portraits of one or two people)
	Night portrait (for taking portraits of large numbers of people, or images in which the background takes up a large portion of the frame)
	Night landscape
	Close-up
	Backlighting (for taking pictures of subjects other than people)
	Backlighting (for taking portrait pictures)
	Underwater*
	Other shooting conditions

* The camera is switched to underwater mode when it is lowered into water.

Notes About (Scene Auto Selector) Mode

- Under some shooting conditions, the camera may not select the desired settings. In this case, select another shooting mode (26).
- When the digital zoom is in effect, the shooting mode icon changes to .

After Taking the Camera Out of the Water

After taking the camera out of water, sometimes it may not automatically switch to another scene from underwater mode.





Gently brush any water droplets with your hand from the camera or wipe it off with a soft and dry cloth. See “Cleaning After Using the Camera Underwater” (189) for more information on caring for the camera.

Underwater Recording of Location Data

See “Underwater Recording of Location Data” (36) for more information.







Functions Available in (Scene Auto Selector) Mode

- Flash mode ( 50)
- Self-timer ( 52)
- Exposure compensation ( 55)
- Image mode ( 128)























Scene Mode (Shooting Suited to the Shooting Conditions)

Select any one of scene modes based on the shooting conditions, and you can take pictures with the appropriate settings for those conditions.

Enter shooting mode →  (shooting mode) button →  (second icon from the top*) →  →  → select a scene →  button

* The icon of the last scene selected is displayed.

 Portrait (default setting)	 Night landscape ^{1, 2} (📖32)
 Landscape ^{1, 2}	 Close-up (📖32)
 Time-lapse movie (📖85)	 Food (📖32)
 Sports ² (📖31)	 Fireworks show ^{1, 3} (📖33)
 Night portrait (📖31)	 Backlighting ² (📖33)
 Party/indoor ² (📖31)	 Easy panorama (📖37)
 Beach ²	 Pet portrait (📖34)
 Snow ²	 Multiple exp. Lighten ⁴ (📖35)
 Sunset ^{2, 3}	 Superlapse movie (📖87)
 Dusk/dawn ^{1, 2, 3}	 Underwater ² (📖36)

¹ The camera focuses at infinity.

² The camera focuses on the area in the center of the frame.

³ Use of a tripod is recommended, because the shutter speed is slow. Set **Photo VR** (📖168) to **Off** in the setup menu when using a tripod to stabilize the camera during shooting.

⁴ Use of a tripod is recommended because the shutter speed is slow. When **Nightscape + light trails** is selected, the camera focuses on the area in the center of the frame. When **Nightscape + star trails** or **Star trails** is selected, the camera focuses at infinity.









Tips and Notes About Scene Mode

Sports

- While the shutter-release button is held all the way down, images are captured continuously.
- The camera can capture up to about 5 images continuously at a rate of about 7.5 fps (when **Image mode** is set to  **4608x3456**).
- The frame rate for continuous shooting may become slow depending on the current image mode setting, the memory card used, or shooting conditions.
- Focus, exposure, and hue for the second and subsequent images are fixed at the values determined with the first image.

Night portrait







- On the screen displayed when  **Night portrait** is selected, select  **Hand-held** or  **Tripod**.
-  **Hand-held:**
 - While the  icon on the shooting screen is displayed in green, press the shutter-release button all the way to capture a series of images which are combined into a single image and saved.
 - Once the shutter-release button is pressed all the way, hold the camera still until a still image is displayed. After taking a picture, do not turn the camera off before the screen switches to the shooting screen.
 - If the subject moves while the camera is shooting continuously, the image may be distorted, overlapped, or blurred.
 - Continuous shooting may not be possible in certain shooting conditions.
-  **Tripod:**
 - One image is captured at a slow shutter speed when the shutter-release button is pressed all the way.
 - Vibration reduction is disabled even when **Photo VR** ( 168) in the setup menu is set to **On**.

Party/indoor





- To avoid the effects of camera shake, hold the camera steady. Set **Photo VR** ( 168) to **Off** in the setup menu when using a tripod to stabilize the camera during shooting.







Night landscape

- On the screen displayed when  **Night landscape** is selected, select  **Hand-held** or  **Tripod**.
-  **Hand-held:**
 - While the  icon on the shooting screen is displayed in green, press the shutter-release button all the way to capture a series of images which are combined into a single image and saved.
 - Once the shutter-release button is pressed all the way, hold the camera still until a still image is displayed. After taking a picture, do not turn the camera off before the screen switches to the shooting screen.
 - The angle of view (i.e., the area visible in the frame) seen in the saved image is narrower than that seen on the shooting screen.
 - Continuous shooting may not be possible in certain shooting conditions.
-  **Tripod:**
 - One image is captured at a slow shutter speed when the shutter-release button is pressed all the way.
 - Vibration reduction is disabled even when **Photo VR** ( 168) in the setup menu is set to **On**.

Close-up

- Macro mode ( 54) is enabled and the camera automatically zooms to the closest position at which it can focus.
- You can move the focus area. Press the  button, use the multi selector  to move the focus area, and press the  button to apply the setting.

Food



- Macro mode ( 54) is enabled and the camera automatically zooms to the closest position at which it can focus.
- You can adjust hue by using the multi selector . The hue setting is saved in the camera's memory even after the camera is turned off.
- You can move the focus area. Press the  button, use the multi selector  to move the focus area, and press the  button to apply the setting.



Fireworks show

- The shutter speed is fixed at four seconds.
- Exposure compensation cannot be used (55).

Backlighting





- On the screen displayed when  **Backlighting** is selected, select **ON** or **OFF** to enable or disable the high dynamic range (HDR) function based on the shooting conditions.
- **OFF**: The flash fires to prevent the subject from being hidden in shadow.
 - Press the shutter-release button all the way to capture one image.
- **ON**: Use when taking pictures with very bright and dark areas in the same frame.
 - When the shutter-release button is pressed all the way, the camera shoots images continuously and saves the following two images.
 - A non-HDR composite image
 - An HDR composite image in which the loss of details in highlights or shadows is minimized
 - If there is only enough memory to save one image, an image processed by D-Lighting (74) at the time of shooting, in which dark areas of the image are corrected, is the only image saved.
 - Once the shutter-release button is pressed all the way, hold the camera still until a still image is displayed. After taking a picture, do not turn the camera off before the screen switches to the shooting screen.
 - The angle of view (i.e., the area visible in the frame) seen in the saved image is narrower than that seen on the shooting screen.

Notes About HDR

Use of a tripod is recommended. Set **Photo VR** (168) in the setup menu to **Off** when using a tripod to stabilize the camera.





Pet portrait

- When you point the camera at a dog or cat, the camera detects the face of a dog or cat and focuses on it. By default, the shutter is automatically released when the face of a dog or cat is detected (pet portrait auto release).
- On the screen displayed when  **Pet portrait** is selected, select  **Single** or  **Continuous**.
 -  **Single**: Whenever the face of a dog or cat is detected, the camera captures one image.
 -  **Continuous**: Whenever the face of a dog or cat is detected, the camera captures three images continuously.

Pet Portrait Auto Release and Self-portrait Timer

The following settings can be set when you press the multi selector  (C).





-  **Pet portrait auto release**: The camera automatically releases the shutter when it detects the face of a dog or cat.
 - **Pet portrait auto release** is set to **OFF** after five bursts have been taken.
 - You can also release the shutter by pressing the shutter-release button.
-  **5s Self-portrait timer**: The shutter is released 5 seconds after you press the shutter-release button all the way down. Frame the picture after you press the shutter-release button all the way down.
 - See "Self-timer" (p.52) for more information.
 - The camera focuses on the face of a dog, cat, or human when detected.
 - The camera cannot shoot images continuously.
- **OFF**: The camera releases the shutter when the shutter-release button is pressed all the way down.
 - The camera focuses on the face of a dog, cat, or human when detected.

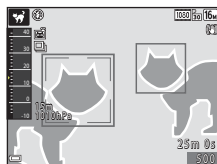

Focus Area



- When the camera detects a face, the face is displayed inside a yellow border. When the camera acquires focus on a face displayed inside a double border (focus area), the double border changes to green. If no faces are detected, the camera focuses on the subject in the center of the frame.
- Under some shooting conditions, the face of a dog, cat, or human may not be detected and other subjects may be displayed inside a border.



Multiple exp. Lighten

- The camera automatically captures moving subjects at regular intervals, compares each image and composites only their bright areas, and then saves them as one image. Light trails such as the flow of car lights or motion of stars are captured.
- On the screen displayed when  **Multiple exp. Lighten** is selected, select  **Nightscape + light trails**,  **Nightscape + star trails**, or  **Star trails**.

Option	Description
 Nightscape + light trails	<p>Use to capture the flow of car lights against a night landscape background.</p> <ul style="list-style-type: none">• Shots are taken at a shutter speed of 4 seconds every 4 seconds. When 50 shots are taken, the camera automatically stops shooting.• For every 10 shots taken, one composite image with trails overlapped from the start of shooting is automatically saved.
 Nightscape + star trails	<p>Use to capture the motion of stars with a night landscape in the frame.</p> <ul style="list-style-type: none">• Shots are taken at a shutter speed of 20 seconds every 25 seconds. When 300 shots are taken, the camera automatically stops shooting.• For every 30 shots taken, one composite image with trails overlapped from the start of shooting is automatically saved.
 Star trails	<p>Use to capture the motion of stars.</p> <ul style="list-style-type: none">• Shots are taken at a shutter speed of 25 seconds every 30 seconds. When 300 shots are taken, the camera automatically stops shooting.• For every 30 shots taken, one composite image with trails overlapped from the start of shooting is automatically saved.

- The screen may turn off during the shooting interval. The power-on lamp flashes while the screen is off.
- To end shooting before it automatically ends, press the  button.
- When you have obtained the desired trails, end shooting. If you continue shooting, details in the composited areas may be lost.
- The images automatically saved during shooting and the image composited when shooting ends are grouped as a sequence, and the image composited when shooting ends is used as the key picture ( 70).
- Vibration reduction is disabled regardless of the **Photo VR** setting ( 168) in the setup menu.

Notes About Multiple Exp. Lighten

- The camera cannot capture images when a memory card is not inserted.
- Do not insert a new memory card until shooting ends.
- Use a sufficiently charged battery to prevent the camera from turning off during shooting.
- Exposure compensation cannot be used ( 55).





Time Remaining

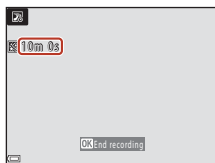

You can check the time remaining until shooting automatically ends on the screen.



Underwater





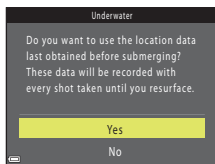

- If you select **Underwater**, screens about recording of location data and water depth calibration are displayed followed by messages about waterproofing. The next message is displayed when you press the multi selector  after reading the messages. When the shutter-release button is pressed, the camera switches to shooting mode without displaying any subsequent screens.
- See "<Important> Notes About Shockproof, Waterproof, and Dustproof Performance and Condensation" () for more information on shooting underwater.
- Wireless communication is not available when the camera is underwater.

Underwater Recording of Location Data



The screen on the right is displayed if you select **Underwater** scene mode or select  (scene auto selector) mode and then submerge the camera underwater while positioning is being performed or while location data is being downloaded from a smart device. If you select **Yes** and press the  button, the location data obtained prior to underwater shooting is recorded on the images to be shot underwater.



Shooting with Easy Panorama

Enter shooting mode →  (shooting mode) button →  (second icon from the top*) →  →  →  →  button

* The icon of the last scene selected is displayed.

- 1 Select  **Normal** or  **Wide** as the shooting range and press the  button.

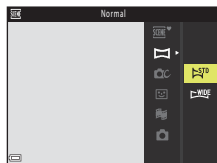



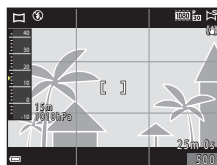

- 2 Frame the first edge of the panorama scene, and then press the shutter-release button halfway to focus.

- The zoom position is fixed at wide-angle.
- The camera focuses in the center of the frame.



- 3 Press the shutter-release button all the way, and then remove your finger from the shutter-release button.

-     are displayed to indicate the direction of camera movement.



- 4 Move the camera in one of the four directions until the guide indicator reaches the end.

- When the camera detects which direction it is moving in, shooting begins.
- Shooting ends when the camera captures the specified shooting range.
- Focus and exposure are locked until shooting ends.

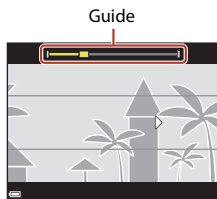

Example of Camera Movement

- Using your body as the axis of rotation, move the camera slowly in an arc, in the direction of the marking (△▽◁▷).
- Shooting stops if the guide does not reach the edge within about 15 seconds (when **STD Normal** is selected) or within about 30 seconds (when **WIDE Wide** is selected) after shooting starts.



✓ Notes About Easy Panorama Shooting

- The range of the image seen in the saved image is narrower than that seen on the screen at the time of shooting.
- If the camera is moved too quickly or shaken too much, or if the subject is too uniform (e.g. walls or darkness), an error may occur.
- If shooting is stopped before the camera reaches the half-way point in the panorama range, a panorama image is not saved.

📎 Image Size of Easy Panorama

- There are four different maximum image sizes (in pixels), as described below.

When **STD Normal** is set

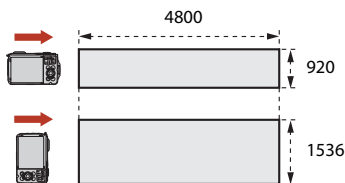

When **WIDE Wide** is set

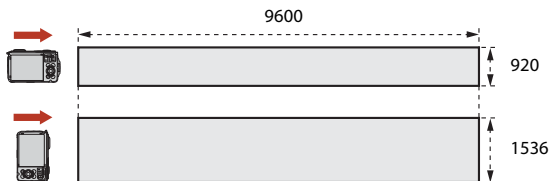

- If more than half of the panorama range is captured but shooting ends before reaching the edge of the range, the image size becomes smaller.



Playback with Easy Panorama

Switch to playback mode (📖21), display an image captured using easy panorama in full-frame playback mode, and then press the **OK** button to scroll the image in the direction that was used when shooting.

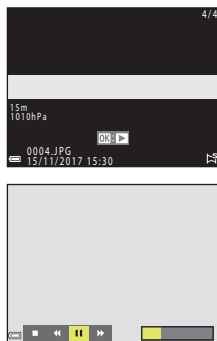

Playback controls are displayed on the screen during playback.

Use the multi selector **◀▶** to select a control, and then press the **OK** button to perform the operations described below.

Function	Icon	Description
Rewind		Hold down the OK button to rewind scroll playback.
Fast-forward		Hold down the OK button to fast-forward scroll playback.
Pause		Pause playback. The operations listed below can be performed while paused.
		Hold down the OK button to rewind.
		Hold down the OK button to scroll.
		Resume automatic scrolling.
End		Return to full-frame playback mode.

✓ Notes About Easy Panorama Images

- The images cannot be edited on this camera.
- This camera may not be able to scroll the playback of, or zoom in on, easy panorama images captured with another make or model of digital camera.



✓ Notes About Printing Panorama Images

The entire image may not be able to be printed depending on the printer's settings. Additionally, printing may not be possible depending on the printer.



Creative Mode (Applying Effects When Shooting)

The camera saves four images with effects and one image without effects simultaneously in one shot.

Enter shooting mode →  (shooting mode) button →  Creative mode →  button



- The camera focuses in the center of the frame.

1 Press the button.

- The effect selection screen is displayed.



2 Use the multi selector to select the desired effect, and press the button.

- You can select **Variety**, **Selective color (red)**, **Selective color (green)**, **Selective color (blue)**, **Light** (default setting), **Depth**, **Memory**, **Classic**, or **Noir**.
- The image without effects is displayed on the upper part of the screen. Four types of images with effects are displayed on the lower part of the screen.
- Only one type of effect can be applied to a movie. Press   to select the desired effect.

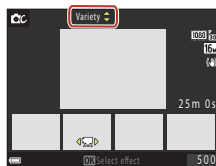

3 Press the shutter-release button or (▶) movie-record) button to shoot.

- The five saved images are treated as a sequence. One image with an applied effect is used as the key picture (70).





Functions Available in Creative Mode

- Flash mode (📖50)
- Self-timer (📖52)
- Macro mode (📖54)
- Exposure compensation (📖55)
- Shooting menu (📖128)



Smart Portrait Mode (Enhancing Human Faces When Shooting)











You can take a picture with the glamour retouch function to enhance human faces.

Enter shooting mode →  (shooting mode) button →  Smart portrait mode →  button

1 Press the multi selector .



2 Apply an effect.

- Use   to select an effect.
- Use   to adjust the amount of effect.
- You can simultaneously apply multiple effects.
 **Skin softening**,  **Foundation makeup**,
 **Soft**,  **Vividness**,  **Brightness (Exp. +/-)**
- Select  **Exit** to hide the slider.
- Press the  button after checking the settings for all effects.

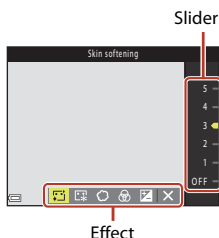

3 Frame the picture and press the shutter-release button.

Notes About Smart Portrait Mode

The amount of effect may differ between the image on the shooting screen and the saved image.

Glamour Retouch Settings

A histogram is displayed when you select **Brightness (Exp. +/-)**. See "Using the Histogram" (p.55) for more information.



Functions Available in Smart Portrait Mode

- Glamour retouch (📖42)
- Smile timer (📖44)
- Self-Collage (📖45)
- Flash mode (📖50)
- Self-timer (📖52)
- Smart portrait menu (📖139)

Using Skin Softening and Foundation Makeup



- When smart portrait mode is set to **Skin softening** or **Foundation makeup** and the camera detects a human face, it processes the image to soften facial skin tones or adjust facial colors before saving the image (up to three faces).
- You can also save images with the **Skin softening** effect applied when shooting in **SCENE** (scene auto selector) mode, or **Portrait** or **Night portrait** scene mode. The amount of effect cannot be adjusted.
- You can also apply the effects of **Skin softening** or **Foundation makeup** in **Glamour retouch** in the playback menu after shooting (📖75).



✓ Notes About Skin Softening and Foundation Makeup

- It may take more time than usual to save images after shooting.
- Under some shooting conditions, the desired results may not be achieved, and the effects may be applied to areas of the image where there are no faces.



Using Smile Timer



Enter shooting mode →  (shooting mode) button →  Smart portrait mode →  button

When you press the multi selector  to select  **Smile timer** and press the  button, the camera automatically releases the shutter whenever a smiling face is detected.

- Set the glamour retouch function before selecting smile timer (42).
- When you press the shutter-release button to take a picture, smile timer is terminated.



Notes About Smile Timer

- Under some shooting conditions, the camera may be unable to detect faces or smiles (58). The shutter-release button can also be used for shooting.
- This function may not be available to use in combination with other functions (64).

When the Self-timer Lamp Flashes

When using smile timer, the self-timer lamp flashes when the camera detects a face and flashes quickly immediately after the shutter is released.



Using Self-Collage

The camera can capture a series of four or nine images at intervals and save them as a one-frame image (a collage image).



Enter shooting mode → (shooting mode) button → Smart portrait mode → button

1 Press the multi selector to select **Self-Collage**, and press the button.

- A confirmation dialog is displayed.
- When you press the **MENU** button and select **Self-Collage** before pressing , you can configure the settings for **Number of shots**, **Interval**, and **Shutter sound** (139).
- If you want to apply glamour retouch when shooting, set the effect before selecting self-collage (42).

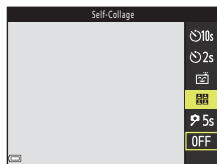

2 Take a picture.

- When you press the shutter-release button, a countdown starts (about five seconds) and the shutter is automatically released.
- The camera automatically releases the shutter for the remaining pictures. A countdown starts about three seconds before shooting.
- The number of shots is indicated by on the screen. It is displayed in yellow during shooting and it changes to white after shooting.

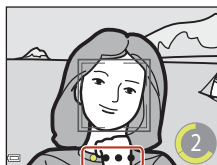

3 On the screen displayed when the camera finishes taking the number of shots that is set in **Number of shots**, select **Yes** and press the **OK** button.

- The collage image is saved.
- Each captured image is saved as an individual image separate from the collage image. The images are grouped as a sequence, and a one-frame collage image is used as the key picture (📖70).
- When **No** is selected, the collage image is not saved.



Notes About Self-Collage



- If you press the shutter-release button before the camera takes the specified number of shots, shooting is canceled and the collage image is not saved. The pictures that were taken before shooting was canceled are saved as individual images.
- This function may not be available to use in combination with other functions (📖64).







(Auto) Mode

Select this mode to perform general shooting in a variety of shooting conditions.

Enter shooting mode →  (shooting mode) button →  (auto) mode →  button



- You can change how the camera selects the area of the frame to focus on by changing the **AF area mode** setting (135). The default setting is **Target finding AF** (59).

Functions Available in (Auto) Mode

- Creative slider (47)
- Flash mode (50)
- Self-timer (52)
- Macro mode (54)
- Shooting menu (128, 130)

Using the Creative Slider







You can adjust the brightness (exposure compensation), vividness, hue, and Active D-Lighting when shooting.

Enter shooting mode →  (shooting mode) button →  (auto) mode →  button

- 1 Press the multi selector .



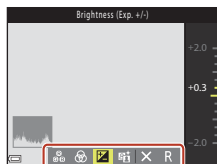

2 Use ◀▶ to select an item.

-  **Hue:** Adjust the hue (reddish/bluish) of the entire image.
-  **Vividness:** Adjust the vividness of the entire image.
-  **Brightness (Exp. +/-):** Adjust the brightness of the entire image.
-  **Active D-Lighting:** Reduce the loss of details in highlights and shadows. Select  **H** (High),  **N** (Normal),  **L** (Low) for the amount of effect.



3 Use ▲▼ to adjust the level.

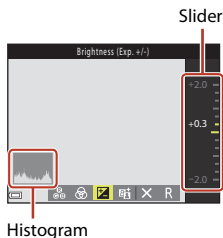

- You can preview the results on the screen.
- To set another item, return to step 2.
- Select  **Exit** to hide the slider.
- To cancel all settings, select  **Reset** and press the  button. Return to step 2 and adjust the settings again.



4 Press the button when setting is complete.

- The settings are applied and the camera returns to the shooting screen.

Creative Slider Settings

- This function may not be available to use in combination with other functions (64).
- The settings for brightness (exposure compensation), vividness, hue, and Active D-Lighting are saved in the camera's memory even after the camera is turned off.
- See "Using the Histogram" (55) for more information.

Active D-Lighting Versus D-Lighting

- The **Active D-Lighting** option in the shooting menu captures images while reducing loss of details in highlights, and adjusts the tone when saving images.
- The **D-Lighting** (74) option in the playback menu adjusts the tone of saved images.



Setting Shooting Functions with the Multi Selector

When the shooting screen is displayed, you can press the multi selector ▲ (⚡) ◀ (⌚) ▼ (🌸) ▶ (📷) to set the functions described below.



- **⚡ Flash mode**
The flash mode can be set according to shooting conditions.
- **⌚ Self-timer, Self-portrait timer**
The camera releases the shutter when the set number of seconds elapses after you press the shutter-release button.
- **🌸 Macro mode**
Use macro mode when you take close-up pictures.
- **📷 Exposure compensation**
You can adjust overall image brightness.

The functions that can be set vary depending on the shooting mode.



Flash Mode

The flash mode can be set according to shooting conditions.

- 1 Press the multi selector ▲ (⚡).



- 2 Select the desired flash mode (📖51) and press the OK button.

- If the setting is not applied by pressing the OK button, the selection will be canceled.

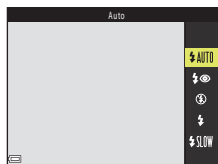

The Flash Lamp

The status of the flash can be confirmed by pressing the shutter-release button halfway.

- On: The flash fires when you press the shutter-release button all the way down.
- Flashing: The flash is charging. The camera cannot shoot images.
- Off: The flash does not fire when a picture is taken.

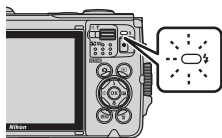

Available Flash Modes



Auto

The flash fires when necessary, such as in dim lighting.

- The flash mode indicator is only displayed immediately after setting on the shooting screen.



Auto with red-eye reduction

Reduce red-eye in portraits caused by the flash.



Off

The flash does not fire.

- We recommend using a tripod to stabilize the camera when shooting in dark surroundings.



Fill flash

The flash fires whenever a picture is taken. Use to “fill-in” (illuminate) shadows and backlit subjects.



Slow sync

Suited to evening and night portraits that include background scenery. The flash fires when necessary to illuminate the main subject; slow shutter speeds are used to capture background at night or under dim lighting.



Notes About Shooting with the Flash

When using the flash at the wide-angle zoom position, the area around the image may be dark depending on the distance to the subject.

This may be improved if you move the zoom control slightly toward the telephoto position.



The Flash Mode Setting

- The setting may not be available with some shooting modes (📖62).
- In the following shooting modes, the setting is saved even after the camera is turned off:
 - **Underwater** scene mode
 - 📷 (auto) mode



Red-eye Reduction

Pre-flashes are fired repeatedly at low intensity before the main flash, reducing the red-eye effect. If the camera detects red-eye while saving an image, the affected area is processed to reduce red-eye before the image is saved.

Note the following when shooting:

- Because pre-flashes are fired, there is a slight lag between when the shutter-release button is pressed and when the image is shot.
- More time than usual is required to save images.
- Red-eye reduction may not produce the desired results in some situations.
- In rare cases, red-eye reduction may be applied to areas of an image unnecessarily. In these cases, select another flash mode and take the picture again.



Self-timer

The camera releases the shutter when the set number of seconds elapses after you press the shutter-release button.

Set **Photo VR** (📖 168) to **Off** in the setup menu when using a tripod to stabilize the camera during shooting.

1 Press the multi selector ◀ (🕒).



2 Select the number of seconds until the shutter is released, and press the **OK** button.

- 🕒10s (10 seconds): Use on important occasions, such as weddings.
- 🕒2s (2 seconds): Use to prevent camera shake.
- 🕒5s (5 seconds, self-portrait timer): Use for self-portraits.
- If the setting is not applied by pressing the **OK** button, the selection will be canceled.

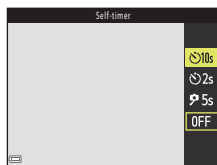

3 Frame the picture and press the shutter-release button halfway.

- When using 🕒10s (10 seconds) or 🕒2s (2 seconds), make sure that the subjects are in focus.
- When using 🕒5s (5 seconds, self-portrait timer), press the shutter-release button all the way down in step 4, and then frame the picture.

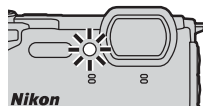

4 Press the shutter-release button all the way down.

- Countdown starts. The self-timer lamp flashes and then glows steadily about one second before the shutter is released.
- When the shutter is released, the self-timer is set to **OFF**.
- To stop the countdown, press the shutter-release button again.





Focus and Exposure When Shooting with the Self-timer

-  10s,  2s: The focus and exposure are locked when you press the shutter-release button all the way down.
-  5s: The focus and exposure are set right before the shutter is released.



The Self-timer Setting

The setting may not be available with some shooting modes ( 62).



Macro Mode (Taking Close-up Pictures)

Use macro mode when you take close-up pictures.

- 1 Press the multi selector ▼ (🌸).



- 2 Select **ON** and press the (OK) button.

- If the setting is not applied by pressing the (OK) button, the selection will be canceled.

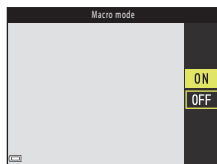

- 3 Move the zoom control to set the zoom ratio to a position where 🌸 and the zoom indicator are displayed in green.



- When the zoom ratio is set to a position where the zoom indicator is displayed in green, the camera can focus on subjects as close as approximately 10 cm (4 in.) from the lens.
When the zoom is at the position where 🌸 is displayed, the camera can focus on subjects as close as approximately 1 cm (0.4 in.) from the lens.

The Macro Mode Setting

- The setting may not be available with some shooting modes (📖62).
- In the following shooting modes, the setting is saved even after the camera is turned off:
 - **Superlapse movie** or **Underwater** scene mode
 - Short movie show mode
 - 📷 (auto) mode



Exposure Compensation (Adjusting Brightness)

You can adjust overall image brightness.

- 1 Press the multi selector ► (Z).



- 2 Select a compensation value and press the OK button.

- To brighten the image, set a positive (+) value.
- To darken the image, set a negative (-) value.
- The compensation value is applied, even without pressing the OK button.
- When the shooting mode is smart portrait mode, the glamour retouch screen is displayed instead of the exposure compensation screen (42).
- When the shooting mode is (auto) mode, the creative slider is displayed instead of the exposure compensation screen (47).



Histogram

Exposure Compensation Value

- Exposure compensation cannot be used in the following scene modes:
 - **Night sky (150 minutes)** or **Star trails (150 minutes)** in **Time-lapse movie**
 - **Fireworks show**
 - **Multiple exp. Lighten**
- When the exposure compensation is set while using the flash, the compensation is applied to both the background exposure and the flash output.
- In the following shooting modes, the setting is saved even after the camera is turned off:
 - **Superlapse movie** scene mode
 - Short movie show mode

Using the Histogram

A histogram is a graph showing the distribution of tones in the image. Use as a guide when using exposure compensation and shooting without the flash.

- The horizontal axis corresponds to pixel brightness, with dark tones to the left and bright tones to the right. The vertical axis shows the number of pixels.
- Increasing the exposure compensation value shifts the tone distribution to the right, and decreasing it shifts the tone distribution to the left.



Using the Zoom

When you move the zoom control, the zoom lens position changes.

- To zoom in: Move toward **T**
- To zoom out: Move toward **W**

When you turn the camera on, the zoom moves to the maximum wide-angle position.

- A zoom indicator is displayed on the shooting screen when the zoom control is moved.
- Digital zoom, which allows you to further magnify the subject up to approximately 4× (when **Movie options** (141) is set to **2160p 2160/30p** (4K UHD) or **2160p 2160/25p** (4K UHD), up to approximately 2×) the maximum optical zoom ratio, can be activated by moving and holding the zoom control toward **T** when the camera is zoomed in to the maximum optical zoom position.

Zoom in



Zoom out

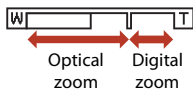

Digital Zoom



The zoom indicator changes to blue when the digital zoom is activated, and it changes to yellow when the zoom magnification is increased further.

- Zoom indicator is blue: Image quality is not noticeably reduced by using the Dynamic Fine Zoom.
- Zoom indicator is yellow: There may be cases in which image quality is noticeably reduced.
- The indicator remains blue across a wider area when the image size is smaller.



Focusing

The Shutter-release Button

<p>Press halfway</p> 	<p>To press the shutter-release button “halfway” means to press and hold the button at the point where you feel a slight resistance.</p> <ul style="list-style-type: none">• Focus and exposure (shutter speed and f-number) are set when you press the shutter-release button halfway. Focus and exposure remain locked while the button is pressed halfway.• The focus area varies depending on the shooting mode.
<p>Press all the way</p> 	<p>To press the shutter-release button “all the way” means to press the button down completely.</p> <ul style="list-style-type: none">• The shutter is released when the shutter-release button is pressed all the way.• Do not use force when pressing the shutter-release button, as this may result in camera shake and blurred images. Press the button gently.



Using Face Detection

In the following settings, the camera uses face detection to automatically focus on human faces.

- **SCENE** (scene auto selector) mode (📖28)
- **Portrait** or **Night portrait** scene mode (📖30)
- Smart portrait mode (📖42)
- When **AF area mode** (📖135) in  (auto) mode (📖47) is set to **Face priority**.

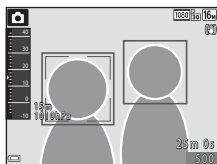

If the camera detects more than one face, a double border is displayed around the face that the camera focuses on, and single borders are displayed around the other faces.

If the shutter-release button is pressed halfway when no faces are detected:

- In **SCENE** (scene auto selector) mode, the focus area changes depending on the shooting conditions that the camera recognizes.
- In **Portrait** and **Night portrait** scene modes or in smart portrait mode, the camera focuses in the center of the frame.
- In  (auto) mode, the camera selects the focus area containing the subject closest to the camera.

Notes About Face Detection

- The camera's ability to detect faces depends on a variety of factors, including the direction in which the faces are looking.
- The camera cannot detect faces in the following situations:
 - When faces are partially hidden by sunglasses or otherwise obstructed
 - When faces take up too much or too little of the frame

Face Detection During Movie Recording

When **AF area mode** (📖145) in the movie menu is set to **Face priority**, the camera focuses on human faces during movie recording. If the  (movie-record) button is pressed when no faces are detected, the camera focuses on the area in the center of the frame.



Using Target Finding AF

When **AF area mode** (📖 135) in 📷 (auto) mode is set to **Target finding AF**, the camera focuses in the manner described below when you press the shutter-release button halfway.

- The camera detects the main subject and focuses on it. When the subject is in focus, the focus area is displayed in green. If a human face is detected, the camera automatically sets focus priority on it.

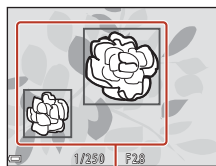

Focus areas

- If no main subject is detected, the camera automatically selects one or more of the nine focus areas containing the subject closest to the camera. When the subject is in focus, the focus areas that are in focus are displayed in green.

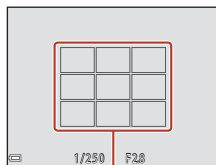

Focus areas

✔ Notes About Target Finding AF

- Depending on shooting conditions, the subject that the camera determines to be the main subject may vary.
- The main subject may not be detected when using certain **White balance** settings.
- The camera may not detect the main subject appropriately in the following situations:
 - When the subject is very dark or bright
 - When the main subject lacks clearly defined colors
 - When the shot is framed so that the main subject is on the edge of the screen
 - When the main subject is composed of a repeating pattern



Subjects Not Suitable for Autofocus

The camera may not focus as expected in the following situations. In rare cases, the subject may not be in focus despite the fact that the focus area or the focus indicator is displayed in green:

- Subject is very dark
- Objects of sharply differing brightness are included in the shooting conditions (e.g. the sun behind the subject makes that subject appear very dark)
- No contrast between the subject and surroundings (e.g. a portrait subject wearing a white shirt is standing in front of a white wall)
- Several objects are at different distances from the camera (e.g. the subject is inside a cage)
- Subjects with repeating patterns (window blinds, buildings with multiple rows of similarly shaped windows, etc.)
- Subject is moving rapidly

In the situations noted above, try pressing the shutter-release button halfway to refocus several times, or focus on another subject positioned at the same distance from the camera as the actual desired subject, and use focus lock (61).



Focus Lock

Focus lock shooting is recommended when the camera does not activate the focus area that contains the desired subject.

1 Set **AF area mode to Center** in  (auto) mode ( 135).

2 Position the subject in the center of the frame and press the shutter-release button halfway.

- The camera focuses on the subject and the focus area is displayed in green.
- Exposure is also locked.

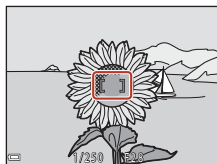

3 Without lifting your finger, recompose the picture.

- Make sure to maintain the same distance between the camera and the subject.



4 Press the shutter-release button all the way down to take the picture.

















Default Settings (Flash, Self-timer, and Macro Mode)

The default settings for each shooting mode are listed below.

	Flash (📷50)	Self-timer (🕒52)	Macro mode (📷54)
 (scene auto selector)	🚫 AUTO ¹	Off	Off ²
Scene modes			
 (portrait)	🚫👁	Off	Off ³
 (landscape)	📷 ³	Off ⁴	Off ³
 (time-lapse movie)	📷 ³	Off	Off ³
 (sports)	📷 ³	Off ³	Off ³
 (night portrait)	🚫👁 ⁵	Off	Off ³
 (party/indoor)	🚫👁 ⁶	Off	Off ³
 (beach)	🚫 AUTO	Off	Off ³
 (snow)	🚫 AUTO	Off	Off ³
 (sunset)	📷 ³	Off	Off ³
 (dusk/dawn)	📷 ³	Off ⁴	Off ³
 (night landscape)	📷 ³	Off ⁴	Off ³
 (close-up)	📷	Off	On ³
 (food)	📷 ³	Off	On ³
 (fireworks show)	📷 ³	Off ³	Off ³
 (backlighting)	🚫/📷 ⁷	Off	Off ³
 (easy panorama)	📷 ³	Off ³	Off ³
 (pet portrait)	📷 ³	📷 ⁸	Off
 (multiple exp. Lighten)	📷 ³	🕒2s	Off ³
 (superlapse movie)	📷 ³	Off	Off
 (underwater)	📷	Off	Off
 (creative mode)	🚫 AUTO	Off	Off
 (smart portrait)	🚫 AUTO ⁹	Off ¹⁰	Off ³
 (short movie show)	📷 ³	Off	Off
 (auto)	🚫 AUTO	Off	Off



- 1 The camera automatically selects the flash mode appropriate for the shooting conditions it has selected.  (off) can be selected manually.
- 2 Cannot be changed. The camera enters macro mode when  is selected.
- 3 Cannot be changed.
- 4  **5s Self-portrait timer** cannot be used.
- 5 Cannot be changed. The flash mode setting is fixed at fill flash with red-eye reduction when **Tripod** is set.
- 6 May switch to slow sync with red-eye reduction flash mode.
- 7 Flash is fixed at  (fill flash) when **HDR** is set to **OFF**, and is fixed at  (off) when **HDR** is set to **ON**.
- 8  **Pet portrait auto release** and  **5s Self-portrait timer** can be used (📖34).  **10s** or  **2s** cannot be used.
- 9 Cannot be used when **Blink proof** is set to **On**.
- 10  **Smile timer** (📖44) and  **Self-Collage** (📖45) can be used in addition to  **10s**,  **2s**, or  **5s Self-portrait timer**.



Functions That Cannot Be Used Simultaneously When Shooting

Some functions cannot be used with other menu settings.

Restricted function	Setting	Description
Flash mode	Continuous (📖132)	When a setting other than Single is selected, the flash cannot be used.
	Blink proof (📖140)	When Blink proof is set to On , the flash cannot be used.
	Underwater flash (📖170)	When Underwater flash is set to On , Auto with red-eye reduction cannot be selected. If Auto with red-eye reduction was selected beforehand, the setting changes to Auto .
Self-timer	AF area mode (📖135)	When Subject tracking is selected, the self-timer cannot be used.
Macro mode	AF area mode (📖135)	When Subject tracking is selected, macro mode cannot be used.
Image mode	Continuous (📖132)	Image mode is set as follows depending on the continuous shooting setting: <ul style="list-style-type: none"> • Pre-shooting cache: 1M (image size: 1280 × 960 pixels). • Continuous H: 120 fps: VGA (image size: 640 × 480 pixels) • Continuous H: 60 fps: 1M (image size: 1280 × 960 pixels)
White balance	Hue (using the creative slider) (📖47)	When hue is adjusted using the creative slider, White balance in the shooting menu cannot be set. To set White balance , select R in the creative slider setting screen to reset the brightness, vividness, hue, and Active D-Lighting.
Continuous	Self-timer (📖52)	When the self-timer is used, a single shot is taken even if Pre-shooting cache has been set.
ISO sensitivity	Continuous (📖132)	When Pre-shooting cache , Continuous H: 120 fps , or Continuous H: 60 fps is selected, ISO sensitivity is fixed at Auto .



Restricted function	Setting	Description
AF area mode	Hue (using the creative slider) (📖47)	When hue is adjusted using the creative slider in Target finding AF mode, the camera does not detect the main subject. To detect the main subject, select R in the creative slider setting screen to reset the brightness, vividness, hue, and Active D-Lighting.
	White balance (📖130)	When a setting other than Auto is selected for White balance in Target finding AF mode, the camera does not detect the main subject.
Blink proof	Smile timer (📖44)	When Smile timer is set, Blink proof is disabled.
	Self-Collage (📖45)	When Self-Collage is set, Blink proof is disabled.
Date stamp	Continuous (📖132)	When a setting other than Single is selected, date and time cannot be stamped on images.
	Blink proof (📖140)	When Blink proof is set to On , date and time cannot be imprinted on images.
Photo VR	Flash mode (📖50)	If the flash fires when On (hybrid) is selected, the setting is fixed at On .
	Self-timer (📖52)	If the self-timer is used when On (hybrid) is selected, the setting is fixed at On .
	Continuous (📖132)	If Continuous is set to any setting other than Single when On (hybrid) is selected, the setting is fixed at On .
	ISO sensitivity (📖134)	If ISO sensitivity is set to Fixed range auto or ISO 400 or higher when On (hybrid) is selected, the setting is fixed at On .
Digital zoom	AF area mode (📖135)	When Subject tracking is selected, digital zoom cannot be used.

✓ Notes About Digital Zoom

- Depending on the shooting mode or the current settings, digital zoom may not be available (📖169).
- When digital zoom is in effect, the camera focuses in the center of the frame.



Playback Features

Playback Zoom.....	67
Thumbnail Playback/Calendar Display.....	68
List by Date Mode	69
Viewing and Deleting Images in a Sequence.....	70
Editing Images (Still Images).....	72



Playback Zoom

Moving the zoom control toward **T** (🔍 playback zoom) in full-frame playback mode (📖21) zooms in on the image.



Full-frame Playback



Image is zoomed in.

Displayed area guide

- You can change the magnification rate by moving the zoom control toward **W** (📐) or **T** (🔍).
- To view a different area of the image, press the multi selector ▲▼◀▶.
- When a zoomed image is displayed, press the **OK** button to return to full-frame playback mode.

Cropping Images

When a zoomed image is displayed, you can press the **MENU** button to crop the image to include only the visible portion and save it as a separate file (📖78).



Thumbnail Playback/Calendar Display

Moving the zoom control toward **W** (📷 thumbnail playback) in full-frame playback mode (📖21) displays images as thumbnails.



Full-frame Playback

W
(📷)



T
(🔍)



Thumbnail Playback

W (📷)



W
(📷)



T
(🔍)

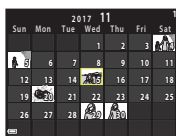

Calendar Display





- You can change the number of thumbnails displayed by moving the zoom control toward **W** (📷) or **T** (🔍).
- While using thumbnail playback mode, press the multi selector **▲▼◀▶** to select an image and then press the **OK** button to display that image in full-frame playback mode.
- While using calendar display mode, press **▲▼◀▶** to select a date and then press the **OK** button to display the images captured on that day.

📌 Notes About Calendar Display



Images captured when the camera's date is not set are treated as images captured on January 1, 2017.



List by Date Mode

Press the  button (playback mode) →  button →  List by date →  button

Use the multi selector ▲▼ to select a date and then press the  button to play back the images captured on the selected date.

- Functions in the playback menu (149) can be used for the images in the selected shooting date (except **Copy**).
- The following operations are available while the shooting date selection screen is displayed.
 - **MENU** button: The functions listed below are available.
 - Slide show
 - Protect*
 - * The same settings can be applied to all images captured on the selected date.
 -  button: Deletes all images captured on the selected date.

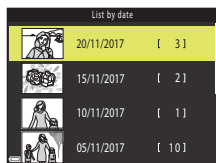

Notes About List by Date Mode

- Up to the most recent 29 dates can be selected. If images exist for more than 29 dates, all images saved earlier than the most recent 29 dates will be combined under **Others**.
- Up to the 9,000 most recent images can be displayed.
- Images captured when the camera's date is not set are treated as images captured on January 1, 2017.



Viewing and Deleting Images in a Sequence

Viewing Images in a Sequence

Images captured continuously, or with the multiple exp. lighten, creative mode, or self-collage function, are saved as a sequence.

One image in a sequence is used as the key picture to represent the sequence when displayed in full-frame playback mode or thumbnail playback mode.

To display each image in the sequence individually, press the **OK** button.



After pressing the **OK** button, the operations listed below are available.

- To display the previous or next image, press the multi selector ◀▶.
- To display images that are not included in the sequence, press ▲ to return to the key picture display.
- To display images in a sequence as thumbnails, or to play them back in a slide show, set **Sequence display options** (📖153) to **Individual pictures** in the playback menu.

✔ Sequence Display Options

- Images captured with cameras other than this camera cannot be displayed as a sequence.
- If the number of sequences saved in a memory card exceeds 1000, images captured thereafter cannot be displayed as a sequence. Delete unnecessary sequences or replace the memory card. However, images that are not saved in a sequence while shooting cannot be displayed as a sequence even if you delete unnecessary sequences.

📎 Playback Menu Options Available When Using Sequence

- When images in a sequence are displayed in full-frame playback mode, press the **MENU** button to select functions in playback menu (📖149).
- If you press the **MENU** button when a key picture is displayed, the following settings can be applied to all images in the sequence:
 - Mark for upload, Protect, Copy



Deleting Images in a Sequence

When the  (delete) button is pressed for images in a sequence, the images that are deleted vary depending on how the images are displayed.

- When the key picture is displayed:
 - **Current image:** All images in the displayed sequence are deleted.
 - **Erase selected images:** When a key picture is selected on the erase selected images screen (23), all images in that sequence are deleted.
 - **All images:** All images on the memory card or in the internal memory are deleted.
- When images in a sequence are displayed in full-frame playback mode:
 - **Current image:** The image currently displayed is deleted.
 - **Erase selected images:** Images that are selected in the sequence are deleted.
 - **Entire sequence:** All images in the displayed sequence are deleted.



Editing Images (Still Images)

Before Editing Images

You can easily edit images on this camera. Edited copies are saved as separate files. Edited copies are saved with the same shooting date and time as the original.

Restrictions on Image Editing





- An image can be edited up to 10 times. A still image created by editing a movie can be edited up to 9 times.
- You may not be able to edit images of a certain size or with certain editing functions.

Quick Effects: Changing Hue or Mood

Type	Description
Painting/Photo illustration/Soft portrait/Portrait (color + B&W)/Fisheye/Cross screen/Miniature effect	Processes images with a variety of effects.
Fog removal	Reduces blurring of images caused by underwater shooting.

- 1 Display the image to which you want to apply an effect in full-frame playback mode and press the  button.



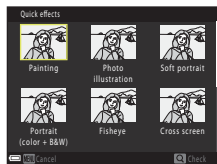

- 2 Use the multi selector  to select the desired effect and press the  button.
 - Move the zoom control  toward **T**  to switch to full-frame playback or **W**  to switch to thumbnail playback.
 - To exit without saving the edited image, press the **MENU** button.





- 3 Select **Yes** and press the  button.
 - An edited copy is created.



Quick Retouch: Enhancing Contrast and Saturation



Press the  button (playback mode) → Select an image → MENU button → Quick retouch →  button

Use the multi selector ▲▼ to select the desired effect level and press the  button.

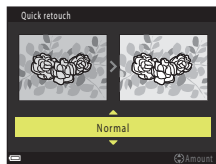
- The edited version is displayed on the right.
- To exit without saving the copy, press .



D-Lighting: Enhancing Brightness and Contrast



Press the  button (playback mode) → Select an image → MENU button → D-Lighting →  button

Use the multi selector ▲▼ to select **OK** and press the  button.

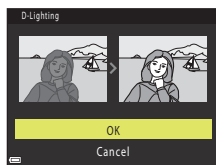
- The edited version is displayed on the right.
- To exit without saving the copy, select **Cancel** and press the  button.



Red-eye Correction: Correcting Red-eye When Shooting with the Flash

Press the  button (playback mode) → Select an image → MENU button → Red-eye correction →  button

Preview the result and press the  button.

- To exit without saving the copy, press the multi selector ◀.

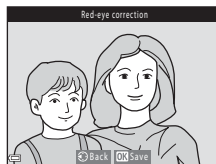





Notes About Red-eye Correction

- Red-eye correction can only be applied to images when red-eye is detected.
- Red-eye correction can be applied to pets (dogs or cats) even if their eyes are not red.
- Red-eye correction may not produce the desired results in some images.
- In rare cases, red-eye correction may be applied unnecessarily to other areas of the image.







Glamour Retouch: Enhancing Human Faces

Press the  button (playback mode) → Select an image → MENU button → Glamour retouch →  button

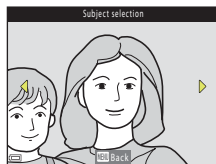

- 1 Use the multi selector  to select the face that you want to retouch and press the  button.

- When only one face is detected, proceed to step 2.











- 2 Use  to select the effect, use  to select the effect level, and press the  button.

- You can simultaneously apply multiple effects. Adjust or check the settings for all effects before pressing the  button.

 **Small face**,  **Skin softening**,

 **Foundation makeup**,  **Glare reduction**,

 **Hide eye bags**,  **Big eyes**,  **Whiten eyes**,  **Eye shadow**,

 **Mascara**,  **Whiten teeth**,  **Lipstick**,  **Redden cheeks**

- Press the MENU button to return to the screen for selecting a person.

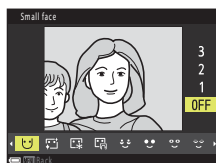

- 3 Preview the result and press the  button.

- To change the settings, press  to return to step 2.
- To exit without saving the edited image, press the MENU button.

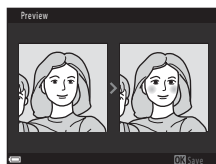

4 Select **Yes** and press the **OK** button.

- An edited copy is created.

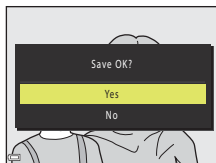



✓ **Notes About Glamour Retouch**

- Only one face at a time can be edited. To retouch another face in the same image, select the edited copy of the image and make additional changes.
- Depending on the direction in which faces are looking, or the brightness of faces, the camera may be unable to accurately detect faces, or the glamour retouch function may not perform as expected.
- If no faces are detected, a warning is displayed and the screen returns to the playback menu.
- The glamour retouch function is available only for images captured at an ISO sensitivity of 1600 or lower, and the image size of 640 × 480 or larger.

Data Imprint: Imprinting Information Such as Electronic Compass Heading on Images

Press the  button (playback mode) → Select an image → **MENU** button → Data imprint → **OK** button

Use the multi selector   to select **OK** and press the **OK** button.

- The following recorded information is imprinted on images.
 - Electronic compass heading
 - Date and time
 - Altitude or water depth
 - Atmospheric pressure
 - Latitude and longitude
- To exit without saving the copy, select **Cancel** and press the **OK** button.

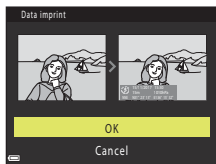





✓ **Notes About Data Imprint**



- Only the information recorded on images is imprinted on the images.
- The information may not be displayed properly if the image size is small.



Small Picture: Reducing the Size of an Image

Press the  button (playback mode) → Select an image → MENU button → Small picture →  button

1 Use the multi selector   to select the desired copy size and press the  button.

- For images captured at an image mode setting of  **4608×2592**, only **640×360** is displayed, and for those of  **3456×3456**, only **480×480** is displayed.

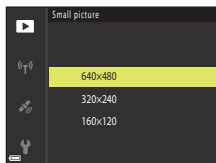

2 Select **Yes** and press the  button.

- An edited copy is created (compression ratio of approximately 1:8).

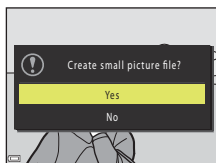

Crop: Creating a Cropped Copy

1 Move the zoom control to enlarge the image (📖67).

2 Adjust the image so that only the portion that you want to keep is displayed, and then press the **MENU** (menu) button.

- Move the zoom control toward **T** (🔍) or **W** (📐) to adjust the magnification rate. Set a magnification rate at which **MENU** : ✂️ is displayed.
- Use the multi selector ▲▼◀▶ to scroll to the portion of the image that you want to display.



3 Confirm the area that you want to keep, and press the **OK** button.

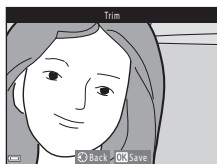

4 Select **Yes** and press the **OK** button.

- An edited copy is created.



Image Size

- The aspect ratio (horizontal and vertical) of the cropped copy is the same as the original.
- When the image size of the cropped copy is 320 × 240 or smaller, the image is displayed at a smaller size during playback.



Movies

Basic Operations of Movie Recording and Movie Playback.....	80
Capturing Still Images While Recording Movies.....	84
Shooting Time-lapse Movies.....	85
Recording Superlapse Movies.....	87
Short Movie Show Mode (Combining Movie Clips to Create Short Movies)...	88
Operations During Movie Playback.....	91
Editing Movies.....	92



Basic Operations of Movie Recording and Movie Playback

1 Display the shooting screen.

- Check the remaining amount of movie recording time.
- It is recommended that you display the movie frame that indicates the area that will be recorded in a movie (📖81).

Movie frame

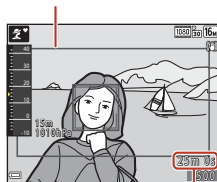

Remaining movie recording time

2 Press the **●** (▶📹 movie-record) button to start movie recording.

- The focus area for autofocus differs depending on the setting of **AF area mode** (📖145).
- Press the **⏸** button to pause recording, and press the **⏹** button again to resume recording (except when an HS movie option is selected in **Movie options**). Recording automatically ends if it remains paused for about five minutes.
- You can capture a still image by pressing the shutter-release button while recording a movie (📖84).

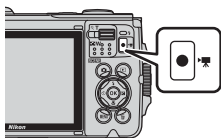

3 Press the **●** (▶📹) button again to end recording.

4 Select a movie in full-frame playback mode and press the **⏹** button to play it back.

- An image with a movie options icon is a movie.

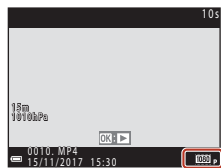

Movie options



Movie Frame

- Set **Photo info** in **Monitor settings** (📖165) in the setup menu to **Movie frame+auto info** to display the movie frame. Check the range of a movie in a frame before movie recording.
- The area that is recorded in a movie varies depending on the settings of **Movie options** or **Movie VR**, etc. in the movie menu.

Exposure

When the multi selector ▶ is pressed during movie recording, the exposure is locked. To unlock, press ▶ again.

Maximum Movie Recording Time

Individual movie files cannot exceed 4 GB in size or 29 minutes in length, even when there is sufficient free space on the memory card for longer recording.

- The remaining recording time for a single movie is displayed on the shooting screen.
- The actual remaining recording time may vary depending on the movie content, subject movement, or type of memory card.
- Memory cards with an SD Speed Class rating of 6 or faster are recommended for recording movies (when recording 4K UHD movies at an image size/frame rate of 2160 P **2160/30p** or 2160 P **2160/25p**, cards rated UHS Speed Class 3 or faster are recommended). When using a memory card with a lower Speed Class rating, movie recording may stop unexpectedly.

✔ Camera Temperature

- The camera may become hot when recording movies for an extended period of time or when the camera is used in a hot area.
- If the inside of the camera becomes extremely hot when recording movies, the camera will automatically stop recording.
The amount of time remaining until the camera stops recording (🔊10s) is displayed. After the camera stops recording, it turns itself off.
Leave the camera off until the inside of the camera has cooled.



Notes About Movie Recording

✓ Notes About Saving Images or Movies

- The indicator showing the number of exposures remaining or the indicator showing the remaining recording time flashes while images or movies are being saved. **Do not open the battery-chamber/memory card slot cover or remove the battery or memory card** while an indicator is flashing. Doing this could result in loss of data, or in damage to the camera or the memory card.
- When using the camera's internal memory, recording movies may take some time.
- Depending on the file size of a movie, it may not be possible to record the movie in the internal memory or copy it from a memory card to the internal memory.

✓ Notes About Recording at Low Temperature

When the battery temperature is below 0°C (32°F), movies with the size/frame rate set to $\frac{2160}{50}$ **2160/30p** (4K UHD), $\frac{2160}{25}$ **2160/25p** (4K UHD), $\frac{1080}{50}$ **1080/60p**, $\frac{1080}{50}$ **1080/50p**, $\frac{480}{60}$ **HS 480/4x**, $\frac{480}{60}$ **HS 480/4x**, $\frac{1080}{15}$ **HS 1080/0.5x**, or $\frac{1080}{15}$ **HS 1080/0.5x** cannot be recorded.

- If the battery temperature goes below 0°C (32°F) before you start recording, the size/frame rate of the movie switches to $\frac{1080}{50}$ **1080/30p** or $\frac{1080}{25}$ **1080/25p**.
- If the size/frame rate of the movie is set to $\frac{2160}{50}$ **2160/30p** (4K UHD), $\frac{2160}{25}$ **2160/25p** (4K UHD), $\frac{1080}{50}$ **1080/60p**, $\frac{1080}{50}$ **1080/50p**, $\frac{480}{60}$ **HS 480/4x**, $\frac{480}{60}$ **HS 480/4x**, $\frac{1080}{15}$ **HS 1080/0.5x**, or $\frac{1080}{15}$ **HS 1080/0.5x** and the battery temperature goes below 0°C (32°F) while recording, the camera may stop recording and turn off automatically. The recorded movie is saved.

✓ Notes About Recorded Movies

- There may be some degradation in image quality when digital zoom is used.
- The sounds of zoom control operation, zoom, autofocus lens drive movement, movie vibration reduction, and aperture operation when brightness changes may be recorded.
- The following phenomena may be seen on the screen while recording movies. These phenomena are saved in the recorded movies.
 - Banding may occur in images under fluorescent, mercury-vapor, or sodium-vapor lighting.
 - Subjects that move quickly from one side of the frame to the other, such as a moving train or car, may appear skewed.
 - The entire movie image may be skewed when the camera is panned.
 - Lighting or other bright areas may leave residual images when the camera is moved.
- Depending on the distance to the subject or the amount of zoom applied, colored stripes may appear on subjects with repeating patterns (fabrics, lattice windows, etc.) during movie recording and playback. This occurs when the pattern in the subject and the layout of the image sensor interfere with each other; it is not a malfunction.

✓ Notes About Vibration Reduction During Movie Recording

- When **Movie VR** (📖147) in the movie menu is set to **On (hybrid)**, the angle of view (i.e., the area visible in the frame) becomes narrower during movie recording.
- When using a tripod to stabilize the camera during shooting, set **Movie VR** to **Off** to prevent potential errors caused by this function.



Notes About Autofocus for Movie Recording



Autofocus may not perform as expected (📖60). Should this occur, try the following:

1. Set **AF area mode** to **Center** and **Autofocus mode** to **Single AF** (default setting) in the movie menu before starting movie recording.
2. Frame another subject (positioned at the same distance from the camera as the intended subject) in the center of the frame, press the ● (🎥 movie-record) button to start recording, and modify the composition.



Capturing Still Images While Recording Movies

If the shutter-release button is pressed all the way while recording a movie, one frame is saved as a still image. Movie recording continues while the still image is being saved.

- A still image can be captured when  is displayed on the screen. When  is displayed, a still image cannot be captured.
- The size of the captured still image is determined by the movie image size (141).



✓ Notes About Capturing Still Images During Movie Recording







- Still images cannot be saved during movie recording in the following situations:
 - When movie recording is paused
 - When the remaining movie recording time is less than five seconds
 - When **Movie options** (141) is set to **2160 P30 2160/30p** (4K UHD), **2160 P25 2160/25p** (4K UHD), **480 P30 480/30p**, **480 P25 480/25p**, or HS movie
- The frames of a movie that were recorded when a still image was being captured may not play back smoothly.
- The sounds of operating the shutter-release button when saving a still image may be heard in the recorded movie.
- If the camera moves when the shutter-release button is pressed, the image may be blurred.







Shooting Time-lapse Movies

The camera can automatically capture still images at a specified interval to create time-lapse movies that are approximately 10 seconds long.

- When the **Frame rate** setting of the movie menu is set to **30 fps (30p/60p)**, 300 images are captured and saved with **1080/60p 1080/30p**. When set to **25 fps (25p/50p)**, 250 images are captured and saved with **1080/25p 1080/25p**.



Enter shooting mode →  (shooting mode) button →  (second icon from the top*) →  →  →  (time-lapse movie) →  button

* The icon of the last scene selected is displayed.

Type (required shooting time)	Interval time	
	30 fps (30p/60p)	25 fps (25p/50p)
 Cityscape (10 minutes) (default setting)	2 s	2.4 s
 Landscape (25 minutes)	5 s	6 s
 Sunset (50 minutes)	10 s	12 s
 Night sky (150 minutes) ¹	30 s	36 s
 Star trails (150 minutes) ²	30 s	36 s

¹ Suited for recording the movement of stars. The focus is fixed at infinity.

² Star movement appears as lines of light due to image processing. The focus is fixed at infinity.

- 1 Use the multi selector  to select a type, and press the  button.

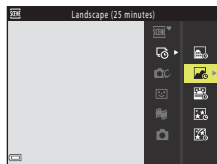

2 Select whether or not to fix exposure (brightness), and press the **OK** button (except and .

- When **AE-L on** is selected, the exposure used for the first image is used for all images. When the brightness changes drastically like at dusk, **AE-L off** is recommended.

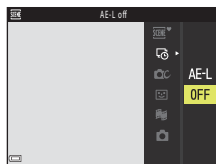



3 Stabilize the camera by using a tool such as a tripod.

4 Press the shutter-release button to capture the first image.

- Set exposure compensation () before releasing the shutter for the first image. Exposure compensation cannot be changed after the first image is captured. Focus and hue are fixed when the first image is captured.
- The shutter is automatically released for the second and subsequent images.
- The screen may turn off while the camera is not capturing images.
- Shooting ends automatically when 300 or 250 images are captured.
- Press the **OK** button to end shooting before the required shooting time elapses and create a time-lapse movie.
- Sound and still images cannot be saved.









Notes About Time-lapse Movie

- The camera cannot capture images if a memory card is not inserted. Do not exchange the memory card until shooting is complete.
- Use a sufficiently charged battery to prevent the camera from turning off unexpectedly.
- Time-lapse movies cannot be recorded by pressing the  (movie-record) button.
- Vibration reduction is disabled regardless of the **Photo VR** setting () in the setup menu.



Recording Superlapse Movies

The camera records movies and saves them in fast motion (**1080 P 60 1080/30p** or **1080 P 25 1080/25p**). Use to record a movie while moving the camera. The camera compresses the time of changes in the subject and saves the movie.

Enter shooting mode →  (shooting mode) button →  (second icon from the top*) →  →  →  (superlapse movie) →  button



* The icon of the last scene selected is displayed.

1 Use the multi selector to select a playback speed, and press the button.

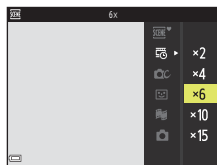
- At the default setting of **6x**, a movie recorded for six minutes is played back as a one-minute movie.
- If an individual movie file reaches 4 GB in size or the recording time exceeds 29 minutes, recording ends automatically.





2 Press the (movie-record) button to start recording.

- The focus area for autofocus differs depending on the setting of **AF area mode** ( 145). The default setting is **Face priority**.
- You can check the recording time and playback time on the screen.
- It is recommended that you display the movie frame that indicates the area that will be recorded in a movie ( 165).
- Sound is not recorded.





Shooting Still Images

- A still image (**16:9 12M 4608x2592**) can be captured if you press the shutter-release button before pressing the  (movie-record) button.
- You can shoot still images while recording movies ( 84).





Short Movie Show Mode (Combining Movie Clips to Create Short Movies)

The camera creates a short movie that is up to 30 seconds long (**1080 P 30 1080/30p** or **1080 P 25 1080/25p**) by recording and automatically combining multiple movie clips that are several seconds long.

Enter shooting mode →  (shooting mode) button →  Short movie show mode →  button

1 Press the MENU (menu) button and configure the settings for recording movies.

- **Number of shots:** Set the number of movie clips that the camera records and the recording time for each movie clip. By default, the camera records 15 movie clips that are 2 seconds each to create a 30-second short movie.
- **Special effects** (90): Apply various effects to movies when shooting. Effects can be changed for each movie clip.
- **Background music:** Select the background music. You can preview it by moving the zoom control (3) toward **T** (.
- After the settings are complete, press the MENU button or shutter-release button to exit the menu.

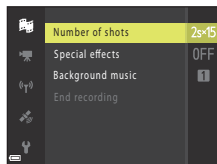

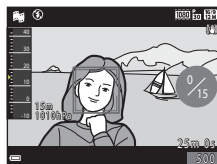

2 Press the (movie-record) button to record a movie clip.

- The camera automatically stops recording the movie clip when the time specified in step 1 elapses.
- Movie clip recording can be paused temporarily. See "Pausing Movie Recording" (89).



3 Check the recorded movie clip, or delete it.

- To check it, press the  button.
- To delete it, press the  button. The last recorded movie clip or all movie clips can be deleted.
- To continue recording movie clips, repeat the operation in step 2.
- To change the effects, return to step 1.

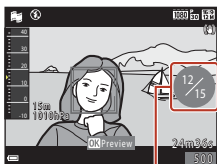

Number of movie clips recorded



4 Save the short movie show.

- The short movie show is saved when the camera finishes recording the specified number of movie clips.
- To save a short movie show before the camera finishes recording the specified number of movie clips, press the **MENU** button when the shooting standby screen is displayed, and then select **End recording**.
- Movie clips are deleted when a short movie show is saved.

Operations During Movie Clip Playback

To adjust the volume, move the zoom control while a movie clip is playing (📖3).

Playback controls are displayed on the screen.

The operations described below can be performed by using the multi selector ◀▶ to select a control and then pressing the **OK** button.



Playback controls

Function	Icon	Description	
Rewind	◀◀	Hold down the OK button to rewind the movie.	
Fast-forward	▶▶	Hold down the OK button to fast-forward the movie.	
Pause		Pause playback. The operations listed below can be performed while paused.	
		◀◀	Rewind the movie one frame. Hold down the OK button for continuous rewinding.
		▶▶	Advance the movie one frame. Hold down the OK button for continuous advancing.
	▶	Resume playback.	
End playback	■	Return to the shooting screen.	
End recording	📁	Save the short movie show using the recorded movie clips.	

✓ Notes About Recording a Short Movie Show

- The camera cannot record movies if a memory card is not inserted.
- Do not exchange the memory card until a short movie show is saved.

📎 Pausing Movie Recording

- A still image (16:9 4608×2592) can be captured if you press the shutter-release button when the shooting standby screen is displayed.
- You can pause movie recording and play back images or enter other shooting modes to take pictures. Movie recording resumes when you enter short movie show mode again.



Functions Available in Short Movie Show Mode

- Self-timer (📖52)
- Macro mode (📖54)
- Exposure compensation (📖55)
- Short movie show menu (📖88)
- Movie options menu (📖141)

Using Special Effects

Apply effects to images during shooting.

Enter shooting mode → 📷 (shooting mode) button → 🎬 Short movie show mode → Ⓞ button → MENU button → Special effects → Ⓞ button

Type	Description
SOFT Soft	Softens the image by adding a slight blur to the entire image.
SEPIA Nostalgic sepia	Adds a sepia tone and reduces the contrast to simulate the qualities of an old photograph.
High-contrast mono.	Creates a black-and-white photograph with a strong contrast.
Selective color	Keeps only a selected color and makes other colors black-and-white.
POP Pop	Increases the color saturation of the entire image to create a bright look.
Cross process	Gives the image a mysterious appearance based on a specific color.
1 Toy camera effect 1	Gives the entire image a yellowish hue and darkens the image periphery.
2 Toy camera effect 2	Decreases the color saturation of the entire image and darkens the image periphery.
OFF Off (default setting)	No effect is applied to the image.

- When **Selective color** or **Cross process** is selected, use the multi selector ▲▼ to select the desired color, and press the Ⓞ button to apply the color.

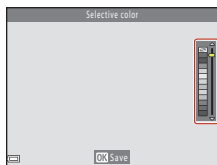

Operations During Movie Playback

To adjust the volume, move the zoom control while a movie is playing (📖3).



Volume indicator

Playback controls are displayed on the screen. The operations described below can be performed by using the multi selector ◀▶ to select a control and then pressing the Ⓞ button.



When paused

Function	Icon	Description	
Rewind	◀◀	Hold down the Ⓞ button to rewind the movie.	
Fast-forward	▶▶	Hold down the Ⓞ button to fast-forward the movie.	
Pause	⏸	Pause playback. The operations listed below can be performed while paused.	
		◀◀	Rewind the movie one frame. Hold down the Ⓞ button for continuous rewinding.
		▶▶	Advance the movie one frame. Hold down the Ⓞ button for continuous advancing.
		▶	Resume playback.
		📄	Extract the desired portion of a movie and save it as a separate file.
End	■	Extract a single frame of a movie and save it as a still image.	
		Return to full-frame playback mode.	



Editing Movies

Extracting Only the Desired Portion of a Movie

The desired portion of a recorded movie can be saved as a separate file.

1 Play back a desired movie and pause at the start point of the portion that you want to extract (📖91).

2 Use the multi selector ◀▶ to select the 📺 control, and then press the Ⓞ button.

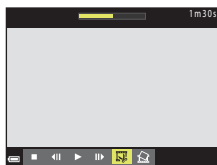

3 Use ▲▼ to select ✂️ (choose start point).

- Use ◀▶ to move the start point.
- To cancel editing, select ⏪ (back), and press the Ⓞ button.

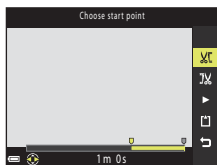

4 Use ▲▼ to select 📺 (choose end point).

- Use ◀▶ to move the end point.
- To preview the specified portion, select ▶ and then press the Ⓞ button. Press the Ⓞ button again to stop previewing.

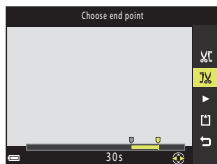

5 Use ▲▼ to select 📁 (save) and press the Ⓞ button.

- Follow the instructions on the screen to save the movie.









✓ Notes About Movie Editing

- Use a sufficiently charged battery to prevent the camera from turning off during editing. When the battery level indicator is , movie editing is not possible.
- A movie that was created by editing cannot be edited again.
- The actual trimmed portion of a movie may differ slightly from the portion selected using the start and end points.
- Movies cannot be trimmed so that they are less than two seconds long.



Saving a Frame from a Movie as a Still Image

The desired frame of a recorded movie can be extracted and saved as a still image.

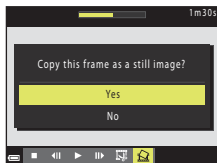
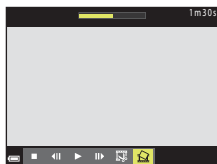
- Pause a movie and display the frame to be extracted (91).
- Use the multi selector  to select the  control and press the  button.
- Select **Yes** when a confirmation dialog is displayed, and press the  button to save the image.
- The image quality of the saved still image is normal (compression ratio of approximately 1:8). The image size is determined by the original movie image size (141).



✓ Restrictions on Extracting Still Images

Still images cannot be extracted from a movie recorded with  **480/30p**,  **480/25p**, or HS movies.





Using Location Data Functions





Operations Available with Location Data Functions.....	95
Recording the Location Data on the Image.....	97
Using Altimeter and Depth Gauge.....	100
Recording the Log of Movement Information.....	101
Displaying Altitude/Depth Logs as a Graph	104
Displaying the Active Guide	105



Operations Available with Location Data Functions

When **Use built-in location data** in **Location data options** in the  (location data options) menu (120) is set to **On**, the camera starts receiving signals from the positioning satellites.

Location data reception can be checked on the shooting screen.

-  or : Signals are being received from four or more satellites, or from three satellites, and location data is being obtained.
- : Signals are being received, but location data cannot be obtained.
- : Signals are not received.

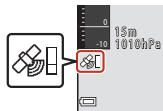

Recording the Shooting Location Data on the Image

- When shooting while positioning is being performed, the obtained location data (latitude and longitude) are recorded on the images to be shot.
- When **Compass display** in **Electronic compass** in the location data options menu is set to **On**, the approximate direction of shooting is also recorded.

Recording the Log

- When selecting **Start all logs** in **Create log** in the location data options menu, while positioning is being performed, the location data, altitude, and water depth data of places you visit with the camera is recorded at the certain interval.
- Recorded logs (movement information such as location data, altitude, or water depth) can be saved on a memory card by selecting **Create log** to stop recording and then selecting **Save logs**.
- The altitude and water depth logs saved on the memory card can be displayed as a graph by selecting **Altitude/depth logs** in **View log** in the location data options menu.
- You can check the graphs of the currently recording altitude and water depth logs on the active guide (105).



Displaying POI Information

- When **Embed POI** in **Points of interest (POI)** in the location data options menu is set to **On** while the camera is positioning, the nearest location name information for the current position is also recorded on the images to be captured.
- When **Display POI** in the location data options menu is set to **On** while the camera is positioning, the nearest location name information for the current position is displayed on the shooting screen and active guide, and the location name recorded on the image is displayed on the playback screen.

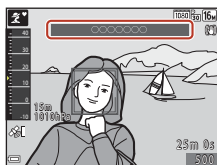

Recording the Location Data on the Image

Press the **MENU** button →  menu icon → Location data options → **OK** button



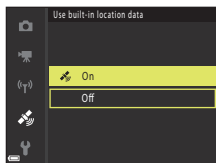

Set **Time zone and date** (📖163) correctly before using the location data functions.

1 Set Use built-in location data to On.

- After the settings are complete, press the **MENU** button or shutter-release button to exit the menu.
- To receive signals easily, operate in an open-air area.



2 Check the location data reception on the shooting screen.

-  or : Signals are being received from four or more satellites, or from three satellites, and location data is being obtained. The location data is recorded on the image.
- : Signals are being received, but location data cannot be obtained. The location data is not recorded on the image.
- : Signals cannot be received from the satellites, and location data cannot be obtained. The location data is not recorded on the image.

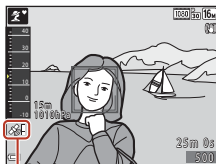

Location data reception

3 Shoot images while positioning is being performed.

- The location data is recorded on shot images.
-  is displayed on images with recorded location data in the camera's playback screen (📖7).



Notes About Location Data Functions

- Before using the location data functions, read “Notes About Location Data Functions (GPS/GLONASS, Electronic Compass)” (📖184).
- It takes a few minutes to obtain location data when positioning is performed for the first time, when positioning cannot be performed for a long period of time, or just after the battery is replaced.
Using the latest A-GPS file can shorten the time needed to obtain the location data (📖157).
- Positions of the positioning satellites change constantly.
You may not be able to determine the position or it may take some time depending on your location and the time.
To use the location data functions, use the camera in an open-air area with few obstacles in the sky. Signal receiving will be smoother if the positioning antenna (📖2) is facing the sky.
- The following locations which block or reflect signals may result in failed or inaccurate positioning.
 - Inside buildings or underground locations
 - Between high-rise buildings
 - Under overpasses
 - Inside tunnels
 - Near high-voltage electrical power lines
 - Between clusters of trees
 - Underwater
- Using a mobile phone of 1.5 GHz band near this camera may disrupt positioning.
- When carrying this camera around while positioning, do not place it in a metal bag. Positioning cannot be performed if the camera is covered with metal materials.
- When there is a significant difference in the signals from the positioning satellites, there could be a deviation of up to several hundred meters.
- Be aware of your surroundings and watch your step when positioning.
- The shooting date and time that is displayed when playing back images is determined by the camera’s internal clock at the time of shooting.
The time at which location data is obtained will be recorded on images, but it will not be displayed on the camera.
- The location data for the first frame will be recorded on a series of images shot using continuous shooting.

Battery Drain While Recording Location Data and Log Recording

- When **Use built-in location data** is set to **On**, record location data functions will continue to operate at the specified interval for approximately six hours even after the camera is turned off. Also, record location data functions and log recording function will continue to operate while recording logs (📖101) even after the camera is turned off.
- When **Use built-in location data** is set to **On** or while recording logs, the battery power will drain faster than usual. Confirm the battery level especially when recording a log using **Start all logs** or **Start location log**.



Updating the A-GPS File

Using the latest A-GPS file can shorten the time needed to obtain the location data.

- 1** Download the latest A-GPS file to the computer from the website below.
 - <http://nikonimglib.com/agps3/>
- 2** Use a card reader or other device to copy the downloaded file to the "NCFL" folder of the memory card.
 - The "NCFL" folder is located directly under the memory card root directory. If the memory card does not have an "NCFL" folder, create a new "NCFL" folder directly under the memory card root directory.
- 3** Insert the memory card containing the copied file into the camera.
- 4** Turn on the camera.
- 5** Press the **MENU** (menu) button to display the location data options menu, and use the multi selector to select **Location data options**.
- 6** Select **Update A-GPS file**, and update the file.
 - About two minutes are needed to update the A-GPS file.

Notes About Updating A-GPS File

- The A-GPS file is disabled when a position is determined for the first time after the camera is purchased. The A-GPS file becomes active from the second operation for determining a location.
- The validity period of the A-GPS file can be checked on the update screen. If the validity period has expired, it is displayed in gray.
- Once the validity period of the A-GPS file has expired, positioning for the location data will not become faster. Updating of the A-GPS file before using the location data functions is recommended.



Using Altimeter and Depth Gauge

You can check the atmospheric pressure as well as the altitude or water depth of the current position on the screen, and record the displayed values to the captured images.

- The altitude, water depth, and atmospheric pressure that are recorded on images can be imprinted on the images by using **Data imprint** (📖76) in the playback menu.
- Captured images and related logs can be displayed if you use the altitude or water depth log recording functions (📖104).

✓ Notes About Altimeter and Depth Gauge

- Use **Alt./depth correction** in **Altitude/depth options** (📖162) in the location data options menu to correct the altitude or water depth in advance. Before using the camera underwater, make sure to adjust the data to 0 m (0 ft) at the surface of water.
- Do not use the altimeter or depth gauge in this camera for specialized applications such as mountain climbing or underwater diving. The displayed information is intended as a general guide only.
- Since the altitude is calculated using the camera's internal barometer, the data may not be displayed correctly in some climate conditions.
- When the scale of the depth gauge display exceeds 25 m (82 ft), the depth gauge display turns orange. When the scale of the depth gauge display exceeds 30 m (98 ft), the depth gauge display turns red.

📎 Altitude or Water Depth

- The altimeter or depth gauge can be displayed when **Altimeter/depth gauge** in **Altitude/depth options** in the location data options menu is set to **On** (default setting).
- The depth gauge and water depth are displayed when you select **Underwater** scene mode, or select **SCENE** (scene auto selector) mode and then submerge the camera underwater. If the camera is not being used underwater when **Underwater** is selected, the depth gauge display is fixed at 0 m (0 ft).
- The display range of the altitude is -300 m to +4500 m (-984 ft to +14,760 ft), and the display range of the water depth is 0 m to 35 m (0 ft to 114 ft).
- When altitude or water depth is corrected, 🛠️ is displayed next to the altitude or water depth.

Altimeter or depth gauge

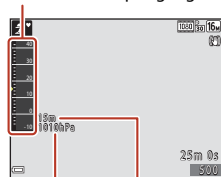



Atmospheric pressure

Altitude or water depth



Recording the Log of Movement Information

Starting Log Recording

Press the MENU button →  menu icon → Create log →  button

1 Use the multi selector ▲▼ to select the type of log to record, and press the .

- **Start all logs:** Location, altitude, and water depth logs are recorded.
- **Start location log:** A location log is recorded.
- **Start depth log:** A water depth log is recorded.

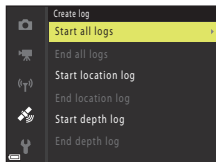

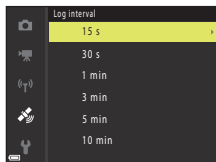

2 Select the intervals of log recording, and press the .

- The intervals that can be set vary depending on the type of log that is recorded.



3 Select the duration of the log recording, and press the .

- The time that can be set varies depending on the type of log that is recorded.
- Log recording starts. Press the MENU button to exit the menu.
- **LOG** is displayed on the shooting screen during log recording (6).
- Log recording automatically ends when the specified time elapses, and the log data is temporarily recorded on the camera. Save the log data on a memory card when log recording is complete (103).

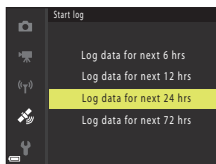



Notes About Log Recording

- If the date and time are not set, the log cannot be recorded.
- When recording all logs or a water depth log, correct the altitude or water depth using **Alt./depth correction** in **Altitude/depth options** (📖162) in the location data options menu before log recording starts.
- Use a sufficiently charged battery to prevent the camera from turning off during log recording. When the battery power becomes exhausted, log recording ends. While location logs are recorded, the battery is exhausted much faster. Exercise caution regarding the remaining battery level.
- Log data cannot be recorded while the camera is not positioning, even if log recording has already started.
- Even when the camera is turned off, log recording is continuously performed until the preset time has elapsed if there is still time remaining for log recording.
- Log recording ends due to the operations below even when there is time remaining for log recording.
 - The battery is removed
 - **Use built-in location data** in **Location data options** is set to **Off** (except when **Start depth log** is used to start recording a depth log).
 - **Reset all** in the setup menu is performed
 - The setting of the internal clock (time zone or date and time) is changed
 - An option to end log recording is selected in **Create log** in the location data options menu (📖103)
- Log recording is paused during the operations below.
 - During continuous shooting
 - During movie recording
 - When connected with a USB cable or HDMI cableLog recording is resumed when the above operations are finished.
- The log data is temporarily saved in the camera. New logs cannot be recorded if the log data remains in the camera. After recording log data, save it on a memory card (📖103).



Ending Log Recording and Saving Logs on a Memory Card

Press the **MENU** button →  menu icon → Create log →  button

Recorded logs must be saved on a memory card in order to display them as a graph.

1 When log recording is completed, select the log to end and press the  button.

- You can select the log to end recording before the specified time duration elapses.

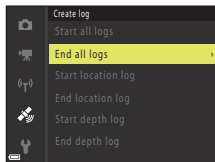

2 Select **Save logs**, and press the  button.

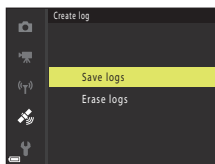

- The log data is saved on a memory card.
- To check if the log data was saved to the memory card, select **View log** in the location data options menu.



Notes About Log Data

- No log data is saved if the camera is unable to calculate any location data between the time that log recording starts and ends.
- See "Log Data Saved on Memory Cards" (207) for more information.

To Erase Log Data

- To erase the log data that is temporarily saved in the camera, select **Erase logs** in step 2.
- To erase the log data that is saved on the memory card, select **Location logs** or **Altitude/depth logs** in **View log** (160), and press the  button.

Location Log Data

Log data is NMEA format-compliant. However, the log data is not guaranteed to display in all NMEA format-compliant software or cameras.



Displaying Altitude/Depth Logs as a Graph

Press the **MENU** button → menu icon → View log → button → Altitude/depth logs → button

- Select a log (date) that you want to display and press the button to display the altitude or water depth data as a graph.
 - The horizontal axis of the graph shows the total time of log recording, and the vertical axis of the graph shows the total variations in altitude/depth during log recording.
 - If images were captured while the log was being recorded, they are displayed as thumbnails, and shooting points are displayed on a graph.
- Press the button when the log list screen is displayed to delete the selected log or all saved altitude/depth logs.
- The operations described below can be performed while a graph is displayed.

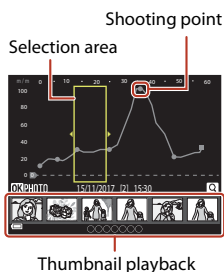



Operation	Description	
MENU button	Return to the log list screen.	
Multi selector	Use to move the yellow selection area. <ul style="list-style-type: none"> • The yellow selection area is displayed when the camera obtains more than 30 recorded logs. 	
Zoom control	Move toward T () to zoom in on the area inside the selection area. <ul style="list-style-type: none"> • Use to move the displayed area. • Move toward W () to return to the full graph display. 	
	Thumbnail images are selected, and operations described below can be performed.	
	Multi selector	Use to switch the selected image. <ul style="list-style-type: none"> • The shooting point of the selected image changes to yellow on the graph.
	Zoom control	<ul style="list-style-type: none"> • T (): Display the selected image in full-frame playback mode. Use to display the previous or next image. • W (): Return to the graph display.
	OK button	Return to the graph operation screen.



Displaying the Active Guide

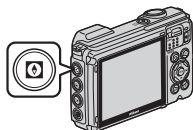

Press the  (tool) button to display the active guide, which allows you to check location data that is currently being obtained.

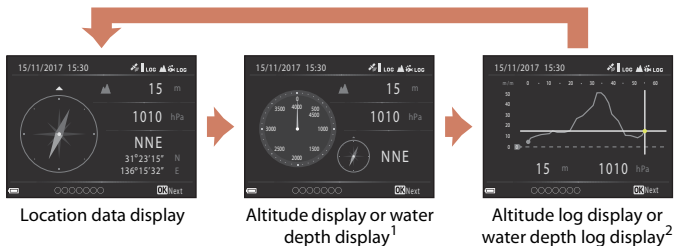

You can switch the displayed information by pressing the  button while the active guide is displayed.



- ¹ Water depth is displayed when using **Underwater** scene mode or when the camera detects that it is underwater.
- ² A graph of the altitude log or water depth log currently being recorded is displayed. When the camera detects that it is underwater, a graph of the water depth log is displayed. When the altitude log or water depth log is not being recorded, a graph is not displayed.

- To exit the active guide, press the  button.
- To switch to shooting mode from the active guide, press the shutter-release button,  button, or  button.

Notes About the Active Guide

- The active guide cannot be displayed during shooting or while the action menu is displayed.
- Some information cannot be displayed when the camera detects that it is underwater.



Notes About Using the Electronic Compass

- Before using the electronic compass, read "Notes About Location Data Functions (GPS/GLONASS, Electronic Compass)" ( 184).
- The electronic compass and heading are not displayed when the camera lens is facing upwards.
- Do not use the electronic compass in this camera for mountain climbing and other specialized applications. The displayed information is intended as a general guide only.
- Direction may not be measured correctly near the following objects:
magnets, metals, electrical motors, electrical home appliances or electrical power cables.
- Direction may not be measured correctly in the following places:
in automobiles, trains, ships, airplanes, inside buildings or in underground malls
- Direction may not be measured correctly if the location data cannot be obtained.



Connecting the Camera to a TV, Printer, or Computer

Utilizing Images	108
Viewing Images on a TV	110
Printing Images Without a Computer	111
Transferring Images to a Computer (NX Studio)	115



Utilizing Images

In addition to using the SnapBridge app to enjoy the captured images, you can also utilize the images in various ways by connecting the camera to the devices described below.

Viewing Images on a TV



Images and movies captured with the camera can be viewed on a TV.

Connection method: Connect a commercially available HDMI cable to the TV's HDMI input jack.

Printing Images Without a Computer



If you connect the camera to a PictBridge-compatible printer, you can print images without using a computer.

Connection method: Connect the camera directly to the printer's USB port with the USB cable.

Transferring Images to a Computer (NX Studio)



You can transfer images and movies to a computer for viewing and editing.

Connection method: Connect the camera to the computer's USB port with the USB cable.

- Before connecting to a computer, install NX Studio on the computer.



✓ Notes About Connecting Cables to the Camera

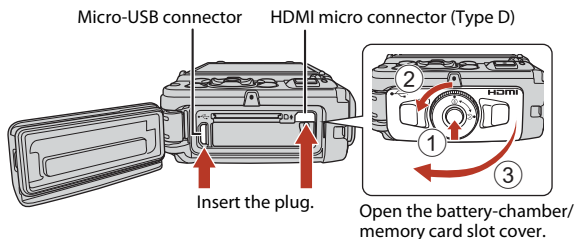

- Make sure to turn the camera off before opening the cover. Check there are no water droplets. If there are water droplets, wipe the camera with a soft dry cloth.
- Make sure to turn the camera off before connecting or disconnecting cables. Check the shape and direction of the plugs and do not insert or remove the plugs at an angle.
- Make sure that the camera battery is sufficiently charged. If the EH-62F AC Adapter (available separately) is used, this camera can be powered from an electrical outlet. Do not, under any circumstances, use an AC adapter other than the EH-62F. Failure to observe this precaution could result in overheating or damage to the camera.
- For information about the connection methods and subsequent operations, refer to the documentation included with the device in addition to this document.



Viewing Images on a TV

1 Turn off the camera and connect it to the TV.

- Check the shape and direction of the plugs and do not insert or remove the plugs at an angle.

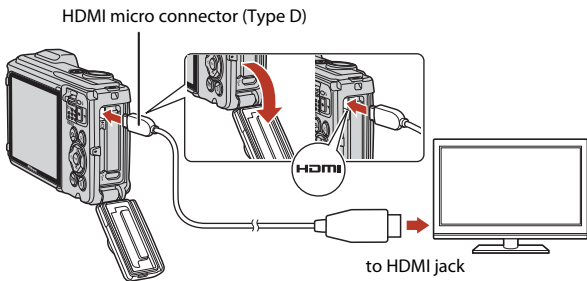

2 Set the TV's input to external input.

- See the documentation provided with your TV for details.

3 Press and hold down the (playback) button to turn on the camera.

- Images are displayed on the TV.
- The camera screen does not turn on.
- To play back movies that were saved using **2160p 2160/30p** (4K UHD) or **2160p 2160/25p** (4K UHD) in 4K UHD quality, use a TV and HDMI cable that support 4K.



Printing Images Without a Computer

Users of PictBridge-compatible printers can connect the camera directly to the printer and print images without using a computer.

Connecting the Camera to a Printer

- 1 Turn on the printer.
- 2 Turn off the camera and connect it to the printer using the USB cable.
 - Check the shape and direction of the plugs and do not insert or remove the plugs at an angle.

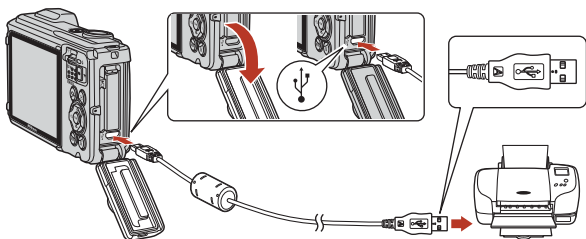

- 3 The camera is automatically turned on.
 - The **PictBridge** startup screen (①) is displayed on the camera screen, followed by the **Print selection** screen (②).

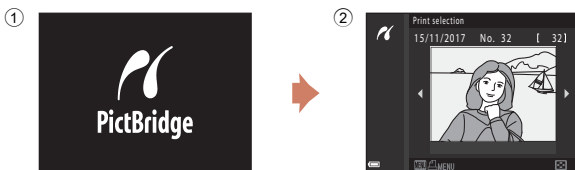

If the PictBridge Startup Screen Is Not Displayed

When **Auto** is selected for **Charge by computer** (176), it may be impossible to print images with direct connection of the camera to some printers. If the PictBridge startup screen is not displayed after the camera is turned on, turn the camera off and disconnect the USB cable. Set **Charge by computer** to **Off** and reconnect the camera to the printer.



Printing Images One at a Time

1 Use the multi selector ◀▶ to select the desired image and press the **OK** button.

- Move the zoom control toward **W** (📐) to switch to thumbnail playback or **T** (📺) to switch to full-frame playback.

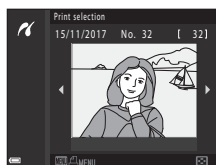

2 Use ▲▼ to select **Copies** and press the **OK** button.

- Use ▲▼ to set the desired number of copies (up to nine) and press the **OK** button.

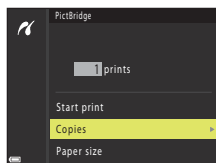

3 Select **Paper size** and press the **OK** button.

- Select the desired paper size and press the **OK** button.
- To print with the paper size setting configured on the printer, select **Default**.
- The paper size options available on the camera vary depending on the printer that you use.

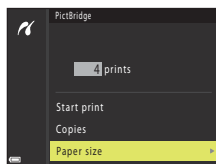

4 Select **Start print** and press the **OK** button.

- Printing starts.

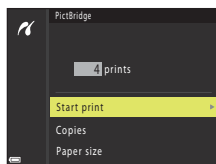

Printing Multiple Images

- 1 When the **Print selection** screen is displayed, press the **MENU** (menu) button.

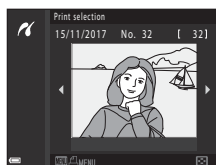

- 2 Use the multi selector ▲▼ to select **Paper size** and press the **OK** button.

- Select the desired paper size and press the **OK** button.
- To print with the paper size setting configured on the printer, select **Default**.
- The paper size options available on the camera vary depending on the printer that you use.
- To exit the print menu, press the **MENU** button.

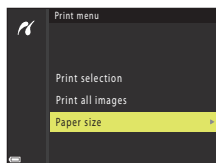

- 3 Select **Print selection** or **Print all images**, and press the **OK** button.

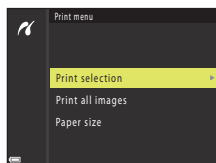

Print selection

Select images (up to 99) and the number of copies (up to 9) of each.

- Use the multi selector ◀▶ to select images, and use ▲▼ to specify the number of copies to be printed.
- Images selected for printing are indicated by 🖨️ and the number of copies to be printed. To cancel the print selection, set the number of copies to 0.
- Move the zoom control toward **T** (🔍) to switch to full-frame playback or **W** (🖼️) to switch to thumbnail playback.
- Press the **OK** button when setting is complete. When the screen for confirming the number of print copies is displayed, select **Start print** and press the **OK** button to start printing.



Print all images

One copy each of all images saved in the internal memory, or on the memory card, is printed.

- When the screen for confirming the number of print copies is displayed, select **Start print** and press the **OK** button to start printing.



Transferring Images to a Computer (NX Studio)

Connect the camera using the supplied USB cable. You can then use Nikon NX Studio software to copy pictures to the computer for viewing and editing.

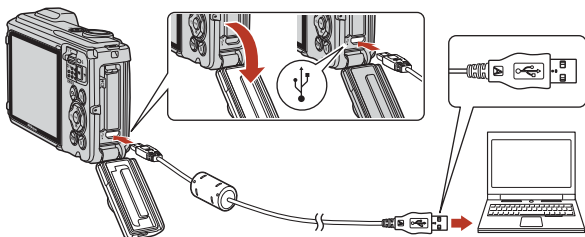

Installing NX Studio

You will need an Internet connection when installing NX Studio. Visit the Nikon website for system requirements and other information.

- Download the latest NX Studio installer from the website below and follow the on-screen instructions to complete installation.
<https://downloadcenter.nikonimglib.com/>
- Note that you may be unable to download pictures from the camera using earlier versions of NX Studio.



Copying Pictures to a Computer Using NX Studio

See online help for detailed instructions.

1 Connect the camera to the computer.

After turning the camera off and ensuring that a memory card is inserted, connect the supplied USB cable as shown.

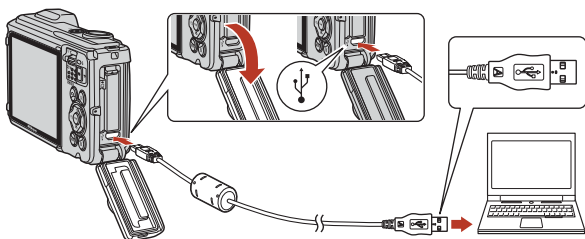

2 Turn the camera on.

- The Nikon Transfer 2 component of NX Studio will start. Nikon Transfer 2 image transfer software is installed with NX Studio.
- If a message is displayed prompting you to choose a program, select Nikon Transfer 2.
- If Nikon Transfer 2 does not start automatically, launch NX Studio and click the "Import" icon.



3 Click **[Start Transfer]**.

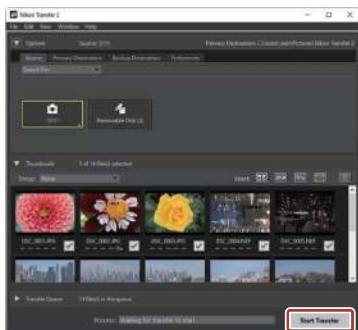

Pictures will be copied to the computer.

4 Turn the camera off.

Disconnect the USB cable when transfer is complete.

✓ **Windows 10 and Windows 8.1**

Windows 10 and Windows 8.1 may display an AutoPlay prompt when the camera is connected.

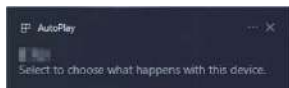

Click the dialog and then click **[Nikon Transfer 2]** to select Nikon Transfer 2.

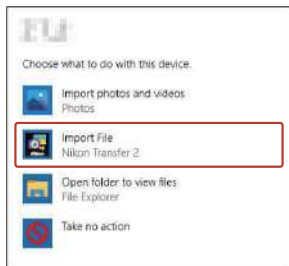

macOS

If Nikon Transfer 2 does not start automatically, confirm that the camera is connected and then launch Image Capture (an application that comes with macOS) and select Nikon Transfer 2 as the application that opens when the camera is detected.

Transferring Videos

Do not attempt to transfer videos from the memory card while it is inserted in a camera of a different make or model. Doing so could result in the videos being deleted without being transferred.

Connecting to Computers

- Do not turn the camera off or disconnect the USB cable while transfer is in progress.
- Do not use force or attempt to insert the connectors at an angle. Be sure also to keep the connectors straight when disconnecting the cable.
- Always turn the camera off before connecting or disconnecting a cable.
- To ensure that data transfer is not interrupted, be sure the camera battery is fully charged.

USB Hubs

Connect the camera directly to the computer; do not connect the cable via a USB hub or keyboard. Connect the camera to a pre-installed USB port.

Using a Card Reader

Pictures can also be copied from a memory card inserted in a third-party card reader. You should however check that the card is compatible with the card reader.









Using the Menu

Menu Operations.....	120
Menu Lists	123
The Shooting Menu (The Common Shooting Options)	128
The Shooting Menu (for  (Auto) Mode).....	130
The Smart Portrait Menu	139
The Movie Menu	141
The Playback Menu.....	149
The Network Menu	154
The Location Data Options Menu	157
The Setup Menu.....	163



Menu Operations

You can set the menus listed below by pressing the **MENU** (menu) button.

-  **Shooting menu**^{1, 2}
-  **Movie menu**¹
-  **Playback menu**^{3, 4}
-  **Network menu**
-  **Location data options menu**
-  **Setup menu**

¹ Press the **MENU** button when the shooting screen is displayed.

² Menu icons and available setting options vary depending on the shooting mode.

³ Press the **MENU** button when the playback screen is displayed.

⁴ Menu icons and available setting options vary depending on the playback mode.

1 Press the **MENU** (menu) button.

- The menu is displayed.

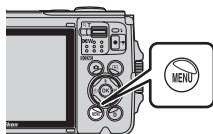

2 Press the multi selector ◀.

- The current menu icon is displayed in yellow.

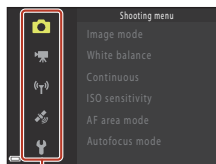

Menu icons

3 Select a menu icon and press the **OK** button.

- The menu options become selectable.

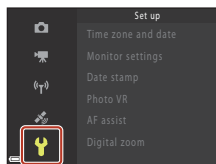

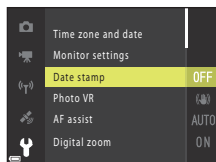

4 Select a menu option and press the **OK** button.

- Certain menu options cannot be set depending on the current shooting mode or the state of the camera.



5 Select a setting and press the **OK** button.

- The setting you selected is applied.
- When you are finished using the menu, press the **MENU** button.
- When a menu is displayed, you can switch to shooting mode by pressing the shutter-release button,  button, or  button.

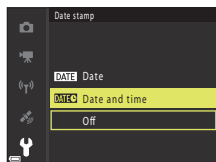

The Image Selection Screen

When an image selection screen such as the one shown on the right is displayed while operating the camera menu, follow the procedures described below to select the images.

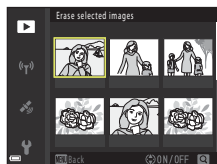

1 Use the multi selector ◀▶ to select the desired image.

- Move the zoom control (📖3) toward **T** (🔍) to switch to full-frame playback, or **W** (📷) to switch to thumbnail playback.
- Only one image can be selected for **Rotate image**. Proceed to step 3.

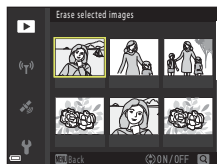

2 Use ▲▼ to select **ON** or **OFF**.

- When **ON** is selected, an icon is displayed under the selected image. Repeat steps 1 and 2 to select additional images.

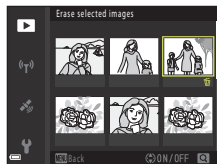

3 Press the **OK** button to apply the image selection.

- When a confirmation dialog is displayed, follow the on-screen instructions to operate.



Menu Lists

The Shooting Menu

Enter shooting mode → MENU button

Common Options

Option	Default setting	
Image mode	16:9 4608x3456	128

For (Auto) Mode



Option	Default setting	
White balance	Auto	130
Continuous	Single	132
ISO sensitivity	Auto	134
AF area mode	Target finding AF	135
Autofocus mode	Pre-focus	138



For Smart Portrait Mode

Option	Default setting	
Self-Collage	-	139
Blink proof	Off	140



The Movie Menu

Enter shooting mode → MENU button →  menu icon →  button

Option	Default setting	
Movie options	 1080/30p or  1080/25p	141
AF area mode	Face priority	145
Autofocus mode	Single AF	146
Movie VR	On (hybrid)	147
Movie light	Off	147
Wind noise reduction	Off	148
Frame rate	-	148



The Playback Menu

Press the  button (playback mode) → MENU button

Option	
Mark for upload ¹	149
Quick retouch ²	73
D-Lighting ²	74
Red-eye correction ²	74
Glamour retouch ²	75
Data imprint ²	76
Slide show	150
Protect ¹	151
Rotate image ¹	151
Small picture ²	77
Copy	152
Sequence display	153

¹ Select an image on the image selection screen. See “The Image Selection Screen” ( 122) for more information.

² Edited images are saved as separate files. Some images may not be edited.

The Network Menu

Press the MENU button →  menu icon →  button

Option	
Airplane mode	154
Connect to smart device	154
Send while shooting	154
Wi-Fi	154
Bluetooth	155
Restore default settings	155



The Location Data Options Menu

Press the **MENU** button →  menu icon →  button

Option	
Location data options	157
Points of interest (POI)	158
Create log	159
View log	160
Set clock from satellite	160
Electronic compass	161
Altitude/depth options	162



The Setup Menu

Press the MENU button →  menu icon →  button

Option	
Time zone and date	163
Monitor settings	165
Date stamp	167
Photo VR	168
AF assist	169
Digital zoom	169
Sound settings	170
Underwater flash	170
Action control response	171
Playback action control	171
Auto off	172
LED light timer	172
Format card/Format memory	173
Language	173
Image comment	174
Copyright information	175
Charge by computer	176
Reset all	177
Conformity marking	177
Firmware version	177



The Shooting Menu (The Common Shooting Options)









Image Mode (Image Size and Quality)

Enter shooting mode → MENU button → Image mode →  button

Select the combination of image size and compression ratio to be used when saving images.

The higher the image mode setting, the larger the size at which it can be printed, and the lower the compression ratio, the higher the quality of the images, but the number of images that can be saved is reduced.

The setting is also applied to other shooting modes.

Option*	Compression ratio	Aspect ratio (horizontal to vertical)
 4608×3456 ★	Approx. 1:4	4:3
 4608×3456 (default setting)	Approx. 1:8	4:3
 3264×2448	Approx. 1:8	4:3
 2272×1704	Approx. 1:8	4:3
 1600×1200	Approx. 1:8	4:3
 640×480	Approx. 1:8	4:3
 4608×2592	Approx. 1:8	16:9
 3456×3456	Approx. 1:8	1:1

* The numerical values indicate the number of pixels that are captured.
Example:  **4608×3456** = approx. 16 megapixels, 4608 × 3456 pixels

Notes About Printing Images at 1:1 Aspect Ratio

Change the printer setting to "Border" when printing images at a 1:1 aspect ratio. Some printers may not be able to print images at a 1:1 aspect ratio.

Notes About Image Mode

- Image mode cannot be set in the following shooting modes:
 - Time-lapse movie**, **Easy panorama**, and **Superlapse movie** scene modes
 - Short movie show mode
- This function may not be available to use in combination with other functions (64).







Number of Images That Can Be Saved

- The approximate number of images that can be saved can be checked on the screen when shooting (📖19).
- Note that due to JPEG compression, the number of images that can be saved may vary greatly depending on the image content, even when using memory cards with the same capacity and the same image mode setting. In addition, the number of images that can be saved may vary depending on the make of the memory card.
- If the number of exposures remaining is 10,000 or more, the number of exposures remaining display shows "9999."







The Shooting Menu (for (Auto) Mode)

White Balance (Adjusting Hue)

Enter shooting mode →  (shooting mode) button →  (auto) mode →  button → MENU button → White balance →  button

Adjust white balance to suit the light source or weather conditions in order to make the colors in images match what you see with your eyes.

Option	Description
AUTO Auto (default setting)	White balance is automatically adjusted.
PRE Preset manual	Use when the desired result is not achieved with Auto , Incandescent , etc. (📖131).
 Daylight	Use under direct sunlight.
 Incandescent	Use under incandescent lighting.
 Fluorescent	Use under fluorescent lighting.
 Cloudy	Use under overcast skies.
 Flash	Use with the flash.

Notes About White Balance

- Set the flash to  (off) when white balance is set to any setting other than **Auto** or **Flash** (📖50).
- This function may not be available to use in combination with other functions (📖64).



Using Preset Manual

Follow the procedures described below to measure the white balance value under the lighting used during shooting.

1 Place a white or gray reference object under the lighting that will be used during shooting.

2 Use the multi selector ▲▼ to select **Preset manual** in the **White balance** menu, and press the **OK** button.

- The lens extends to the zoom position for measurement.

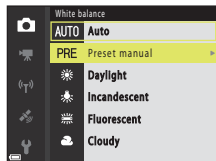

3 Select **Measure**.

- To apply the last measured value, select **Cancel** and press the **OK** button.

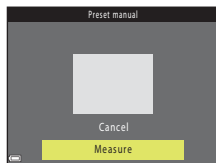

4 Frame the white or gray reference object in the measuring window, and press the **OK** button to measure the value.

- The shutter is released and measurement is complete (no image is saved).

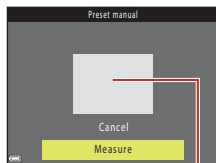





Measuring window













✓ Notes About Preset Manual

A white balance value for flash lighting cannot be measured with **Preset manual**. When shooting using the flash, set **White balance** to **Auto** or **Flash**.



Continuous Shooting

Enter shooting mode →  (shooting mode) button →  (auto) mode →  button → MENU button → Continuous →  button

Option	Description
 Single (default setting)	One image is captured each time the shutter-release button is pressed.
 Continuous H	While the shutter-release button is held all the way down, images are captured continuously. <ul style="list-style-type: none"> The camera can capture up to about 5 images continuously at a rate of about 7.5 fps (when Image mode is set to  4608×3456).
 Continuous L	While the shutter-release button is held all the way down, images are captured continuously. <ul style="list-style-type: none"> The camera can capture up to about 10 images continuously at a rate of about 2.3 fps (when Image mode is set to  4608×3456). When you continue to hold the shutter-release button all the way down, the speed decreases.
 Pre-shooting cache	Pre-shooting cache shooting begins when the shutter-release button is pressed halfway. When the shutter-release button is pressed all the way down, the camera saves the current image as well as the images captured immediately before the button is pressed ( 133). Pre-shooting cache makes it easy to capture perfect moments. <ul style="list-style-type: none"> The camera can capture up to about 25 images continuously at a rate of about 20 fps (including a maximum of 5 images captured in the pre-shooting cache). Image mode is fixed at  (image size: 1280 × 960 pixels).
 Continuous H: 120 fps	Each time the shutter-release button is pressed all the way down, images are captured continuously at a high speed rate. <ul style="list-style-type: none"> The camera can capture up to about 50 images continuously at a rate of about 120 fps. Image mode is fixed at  (image size: 640 × 480 pixels).
 Continuous H: 60 fps	Each time the shutter-release button is pressed all the way down, images are captured continuously at a high speed rate. <ul style="list-style-type: none"> The camera can capture up to about 25 images continuously at a rate of about 60 fps. Image mode is fixed at  (image size: 1280 × 960 pixels).



✓ Notes About Continuous Shooting

- Focus, exposure and white balance are fixed at the values determined with the first shot in each series.
- It may take some time to save the images after shooting.
- When ISO sensitivity increases, noise may appear in captured images.
- The frame rate may become slower depending on the current image mode setting, memory card type or shooting conditions.
- When using **Pre-shooting cache**, **Continuous H: 120 fps**, or **Continuous H: 60 fps**, banding or variance in brightness or hue may occur in images that were captured under lighting that flashes quickly at high speeds, such as fluorescent, mercury-vapor, or sodium-vapor lighting.
- This function may not be available to use in combination with other functions (📖64).

📎 Pre-shooting Cache



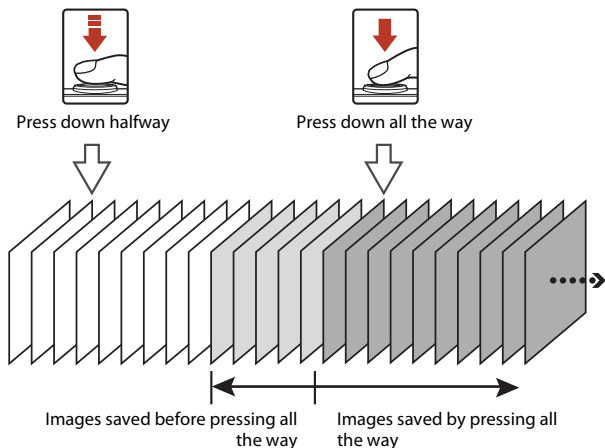

When the shutter-release button is pressed halfway or all the way down, images are saved as described below.



- The pre-shooting cache icon (📎) on the shooting screen changes to green while the shutter-release button is pressed halfway.



ISO Sensitivity

Enter shooting mode →  (shooting mode) button →  (auto) mode →  button → MENU button → ISO sensitivity →  button

A higher ISO sensitivity allows darker subjects to be captured. Additionally, even with subjects of similar brightness, pictures can be taken at faster shutter speeds, and blurring caused by camera shake and subject movement can be reduced.

- When a higher ISO sensitivity is set, images may contain noise.

Option	Description
AUTO Auto (default setting)	Sensitivity is automatically selected from the range of ISO 125 to 1600.
ISO AUTO Fixed range auto	Select the range in which the camera automatically adjusts ISO sensitivity, from ISO 125-400 or ISO 125-800 .
125, 200, 400, 800, 1600, 3200, 6400	Sensitivity is locked at the specified value.

Notes About ISO Sensitivity

This function may not be available to use in combination with other functions ( 64).

ISO Sensitivity Display on the Shooting Screen

- When **Auto** is selected, **ISO** is displayed when the ISO sensitivity increases.
- When **Fixed range auto** is selected, the maximum value for ISO sensitivity is displayed.



AF Area Mode

Enter shooting mode → (shooting mode) button → (auto) mode → button → MENU button → AF area mode → button

Use this option to determine how the camera selects the focus area for autofocus when shooting still images.

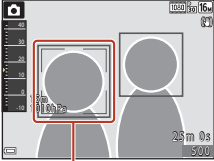
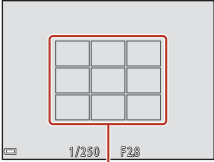
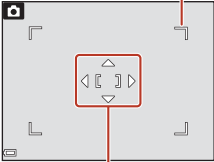
Option	Description
Face priority	<p>When the camera detects a human face, it focuses on that face. See “Using Face Detection” (p.58) for more information.</p>  <p style="text-align: center;">Focus area</p> <p>When framing a composition with no human subjects or detected faces, the camera automatically selects one or more of the nine focus areas containing the subject closest to the camera when the shutter-release button is pressed halfway.</p>  <p style="text-align: center;">Focus areas</p>
Manual	<p>Use the multi selector to move the focus area to where you want to focus.</p> <ul style="list-style-type: none"> To use the multi selector to configure the flash mode or other settings, press the button. To return to moving the focus area, press the button again. <p style="text-align: right;">Scope of movable focus area</p>  <p style="text-align: center;">Focus area</p>

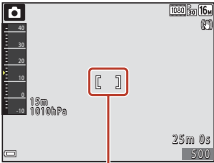
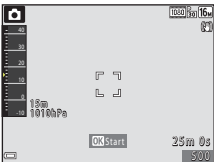
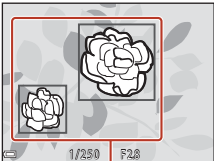

Option	Description	
<p>[▪] Center</p>	<p>The camera focuses on the subject in the center of the frame.</p>	 <p style="text-align: center;">Focus area</p>
<p>⊕ Subject tracking</p>	<p>Use this function to take pictures of moving subjects. Register the subject on which the camera focuses. The focus area automatically moves to track the subject. See “Using Subject Tracking” (📖137) for more information.</p>	
<p>[▪▪] Target finding AF (default setting)</p>	<p>When the camera detects the main subject, it focuses on that subject. See “Using Target Finding AF” (📖59) for more information.</p>	 <p style="text-align: center;">Focus areas</p>

✓ Notes About AF Area Mode







- When digital zoom is in effect, the camera focuses on the area in the center of the frame regardless of the **AF area mode** setting.
- This function may not be available to use in combination with other functions (📖64).

📎 AF Area Mode for Movie Recording



AF area mode for movie recording can be set with **AF area mode** (📖145) in the movie menu.



Using Subject Tracking

Enter shooting mode →  (shooting mode) button →  (auto) mode →  button → MENU button → AF area mode →  button →  Subject tracking →  button → MENU button

1 Register a subject.

- Align the subject that you want to track with the border in the center of the frame and press the  button.
- When the subject is registered, a yellow border (focus area) is displayed around it and the camera begins tracking the subject.
- If the subject cannot be registered, the border is displayed in red. Change the composition and try registering the subject again.
- To cancel subject registration, press the  button.
- If the camera can no longer track the registered subject, the focus area disappears. Register the subject again.

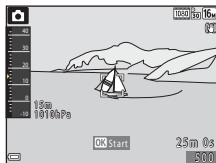

2 Press the shutter-release button all the way to take the picture.

- If the shutter-release button is pressed while the focus area is not displayed, the camera focuses on the subject in the center of the frame.

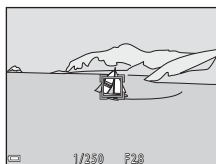





Notes About Subject Tracking

- If you perform operations such as zooming while the camera is tracking the subject, the registration is canceled.
- Subject tracking may not be possible in certain shooting conditions.



Autofocus Mode

Enter shooting mode →  (shooting mode) button →  (auto) mode →  button → MENU button → Autofocus mode →  button

Set how the camera focuses when shooting still images.

Option	Description
AF-S Single AF	The camera focuses only when the shutter-release button is pressed halfway.
AF-F Full-time AF	The camera always focuses even if the shutter-release button is not pressed halfway. The sound of lens drive movement is heard while the camera focuses.
PRE- AF Pre-focus (default setting)	Even if the shutter-release button is not pressed halfway, the camera focuses when subject movement is detected or when the composition of the framed image is significantly changed.

Autofocus Mode for Movie Recording

Autofocus mode for movie recording can be set with **Autofocus mode** ( 146) in the movie menu.



The Smart Portrait Menu

- See “Image Mode (Image Size and Quality)” (📖128) for information about **Image mode**.





Self-Collage

Enter shooting mode → 📷 (shooting mode) button → 😊 Smart portrait mode → Ⓞ button → MENU button → Self-Collage → Ⓞ button

Option	Description
Number of shots	Set the number of shots that the camera automatically captures (number of captured images for an aggregated image). <ul style="list-style-type: none">• 4 (default setting) or 9 can be selected.
Interval	Set the interval time between each shot. <ul style="list-style-type: none">• Short, Medium (default setting), or Long can be selected.
Shutter sound	Set whether to activate the shutter sound when shooting with the self-collage function. <ul style="list-style-type: none">• Standard, SLR, Magic (default setting), or Off can be selected.• The setting that is specified for Shutter sound in Sound settings in the setup menu is not applied to this setting.



Blink Proof

Enter shooting mode →  (shooting mode) button →  Smart portrait mode
→  button → MENU button → Blink proof →  button

Option	Description
 On	<p>The camera automatically releases the shutter twice with every shot and saves one image in which the subject's eyes are open.</p> <ul style="list-style-type: none">• If the camera saved an image in which the subject's eyes may have been closed, the dialog shown on the right is displayed for a few seconds.• The flash cannot be used.
Off (default setting)	Turns the blink proof off.





Notes About Blink Proof

This function may not be available to use in combination with other functions ( 64).





The Movie Menu











Movie Options

Enter shooting mode → MENU button →  menu icon → Movie options →  button

Select the desired movie option to record. Select normal speed movie options to record at normal speed, or HS movie options ([142](#)) to record in slow or fast motion. The movie options that can be selected vary depending on the **Frame rate** setting ([148](#)).

- Memory cards with an SD Speed Class rating of 6 or faster are recommended for recording movies ([218](#)). Memory cards with a UHS Speed Class rating of 3 or faster are recommended when recording 4K UHD movies at an image size/frame rate of  **2160/30p** or  **2160/25p**.

Normal Speed Movie Options



Option (Image size/ Frame rate, File format)	Image size	Aspect ratio (horizontal to vertical)	Max. recording time
 2160/30p (4K UHD)  2160/25p (4K UHD)	3840 × 2160	16:9	Approx. 7 minutes
			Approx. 8 minutes
 1080/30p  1080/25p (default setting)	1920 × 1080	16:9	Approx. 27 minutes
			Approx. 29 minutes
 1080/60p  1080/50p	1920 × 1080	16:9	Approx. 13 minutes
			Approx. 16 minutes
 720/30p  720/25p	1280 × 720	16:9	Approx. 29 minutes
 480/30p  480/25p	640 × 480	4:3	Approx. 29 minutes



HS Movie Options

Recorded movies are played back in fast or slow motion.

See “Recording Movies in Slow Motion and Fast Motion (HS Movie)” (📖144).

Option	Image size Aspect ratio (horizontal to vertical)	Description
 HS 480/4x	640 × 480 4:3	1/4-speed slow motion movies • Max. recording time*: 15 seconds (playback time: 1 minute)
 HS 1080/0.5x	1920 × 1080 16:9	2x speed fast motion movies • Max. recording time*: 2 minutes (playback time: 1 minute)

* While recording movies, the camera can be switched between normal speed movie recording and slow motion or fast motion movie recording. The maximum recording time shown here refers only to the portion of the movie that is recorded in slow motion or fast motion.

Notes About HS Movie

- Sound is not recorded.
- Zoom position, focus, exposure, and white balance are locked when movie recording starts.



Playing Back in Slow Motion and Fast Motion

When recording at normal speed:



When recording at $\frac{480 \text{ P}}{120} / \frac{480 \text{ P}}{60}$ HS 480/4x:

Movies are recorded at 4x normal speed.

They are played back in slow motion at 4x slower speed.

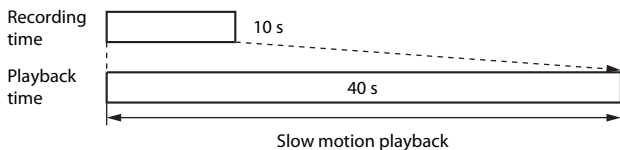



When recording at $\frac{1080 \text{ P}}{120} / \frac{1080 \text{ P}}{60}$ HS 1080/0.5x:

Movies are recorded at 1/2 normal speed.

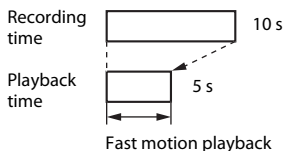



They are played back in fast motion at 2x faster speed.



Recording Movies in Slow Motion and Fast Motion (HS Movie)



Enter shooting mode → MENU button →  menu icon → Movie options →  button

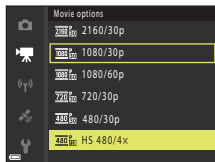

Movies recorded using HS movie can be played back in slow motion at 1/4 of the normal playback speed, or in fast motion at twice the normal playback speed.

1 Use the multi selector   to select an HS movie option ( 142) and press the  button.



- After applying the option, press the MENU button to return to the shooting screen.



2 Press the  ( movie-record) button to start recording.

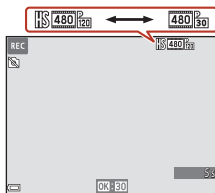

- The camera starts recording an HS movie.
- The camera switches between normal speed movie recording and HS movie recording each time the  button is pressed.
- The movie options icon changes when switching between HS movie recording and normal speed movie recording.
- When the maximum recording time for HS movies ( 142) is reached, the camera automatically switches to normal speed movie recording.





3 Press the  () button to end recording.



AF Area Mode





Enter shooting mode → MENU button →  menu icon → AF area mode →  button

Use this option to determine how the camera selects the focus area for autofocus during movie recording.

Option	Description
 Face priority (default setting)	When the camera detects a human face, it focuses on that face. See “Using Face Detection” (📖58) for more information.
[] Center	The camera focuses on the subject in the center of the frame.



Notes About AF Area Mode for Movie Recording

AF area mode is set to focus on the center in the following situations even when **Face priority** is selected.

- When **Autofocus mode** in the movie menu is set to **Single AF** and no faces are detected before pressing the  () button
- When an HS movie option is selected in **Movie options**
- When **Movie VR** is set to **On (hybrid)** and **Movie options** is set to  **1080/60p** or  **1080/50p**



Autofocus Mode

Enter shooting mode → MENU button →  menu icon → Autofocus mode →  button

Set how the camera focuses when recording movies.

Option	Description
AF-S Single AF (default setting)	Focus is locked when movie recording starts. Select this option when the distance between the camera and the subject will remain fairly consistent.
AF-F Full-time AF	The camera focuses continuously. Select this option when the distance between the camera and subject will change significantly during recording. The sound of the camera focusing may be heard in the recorded movie. Use of Single AF is recommended to prevent the sound of the camera focusing from interfering with recording.

Notes About Autofocus Mode



When an HS movie option is selected in **Movie options**, the setting is fixed at **Single AF**.



Movie VR

Enter shooting mode → MENU button →  menu icon → Movie VR →  button

Select the vibration reduction setting used when recording movies.
Set to **Off** when using a tripod to stabilize the camera during shooting.

Option	Description
 * On (hybrid) (default setting)	Performs optical compensation for camera shake using lens shift VR and simultaneously performs electronic VR using image processing. The angle of view (i.e., the area seen in the frame) becomes narrower.
 On	Performs compensation for camera shake using lens shift VR.
Off	Compensation is not performed.

Notes About Movie VR

- When **Movie options** is set to **2160 P 30 2160/30p** (4K UHD), **2160 P 25 2160/25p** (4K UHD), or HS movie, **On (hybrid)** cannot be selected.
- When **Superlapse movie** is selected, the setting is fixed at **On (hybrid)**.
- Vibration reduction may be unable to completely eliminate the effects of camera shake in some situations.



Movie Light

Enter shooting mode → MENU button →  menu icon → Movie light →  button

Enable or disable the movie light that assists recording in dark places.



Option	Description
On	The movie light turns on automatically for lighting when movie recording starts.
Off (default setting)	The movie light does not turn on. If the LED light is on, it turns off when movie recording starts.

The LED Light During Movie Recording

You can press the  (LED light) button while recording movies to turn on or off the LED light that has the same brightness as the movie light, regardless of the **Movie light** setting (20).



Wind Noise Reduction

Enter shooting mode → MENU button →  menu icon → Wind noise reduction →  button

Option	Description
 On	Reduces the sound that is produced when wind passes over the microphone during movie recording. Other sounds may become difficult to hear during playback.
Off (default setting)	Wind noise reduction is disabled.

Frame Rate

Enter shooting mode → MENU button →  menu icon → Frame rate →  button

Select the frame rate used when recording movies. When the frame rate setting is switched, options that can be set in **Movie options** ( 141) change.



Option	Description
30 fps (30p/60p)	Suited for playback on a TV using the NTSC standard.
25 fps (25p/50p)	Suited for playback on a TV using the PAL standard.



The Playback Menu

- See “Editing Images (Still Images)” (📖72) for information about image editing functions.

Mark for Upload

Press the  button (playback mode) → MENU button → Mark for upload →  button



Select still images in the camera and upload them to a smart device that has a wireless connection established with the SnapBridge app.

On the image selection screen (📖122), select or deselect images to upload.

- The size of images that are uploaded is restricted to 2 megapixels. To upload still images at their original size, use **Download pictures** in the SnapBridge app.
- Movies cannot be selected. To upload movies to a smart device, use **Download pictures** in the SnapBridge app.
- Note that when you select **Reset all** (📖177) in the setup menu or **Restore default settings** (📖155) in the network menu, the Mark for upload settings that you made are canceled.





Slide Show

Press the  button (playback mode) → MENU button → Slide show →  button



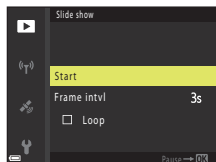

Play back images one by one in an automated “slide show.” When movie files are played back in the slide show, only the first frame of each movie is displayed.

1 Use the multi selector to select **Start** and press the button.

- The slide show begins.
- To change the interval between images, select **Frame intvl**, press the  button, and specify the desired interval time before selecting **Start**.
- To repeat the slide show automatically, select **Loop** and press the  button before selecting **Start**.
- The maximum playback time is up to about 30 minutes even if **Loop** is enabled.





2 End or restart the slide show.

- The screen shown on the right is displayed after the slide show ends or is paused. To exit the show, select  and then press the  button. To resume the slide show, select  and then press the  button.





Operations During Playback

- Use the multi selector  to display the previous/next image. Press and hold down  to rewind/fast-forward images quickly.
- Press the  button to pause or end the slide show.



Protect



Press the  button (playback mode) → MENU button → Protect →  button

The camera protects selected images from accidental deletion.

Select images to protect or cancel protection from the image selection screen (122).

Note that formatting the memory card or the camera's internal memory permanently deletes all data including protected files (173).

Rotate Image

Press the  button (playback mode) → MENU button → Rotate image →  button

Specify the orientation in which saved images are displayed during playback. Still images can be rotated 90 degrees clockwise or 90 degrees counterclockwise.

Select an image from the image selection screen (122). When the Rotate image screen is displayed, press the multi selector  to rotate the image 90 degrees.



Rotate 90 degrees
counterclockwise

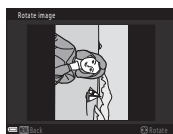



Rotate 90 degrees
clockwise

Press the  button to finalize display orientation, and save orientation information with the image.



Copy (Copy Between the Memory Card and Internal Memory)

Press the  button (playback mode) → MENU button → Copy →  button

Images can be copied between a memory card and the internal memory.

- When a memory card that contains no images is inserted and the camera is switched to playback mode, **Memory contains no images.** is displayed. In that case, press the MENU button to select **Copy**.

- 1 Use the multi selector ▲▼ to select a destination option to which images are copied and press the  button.

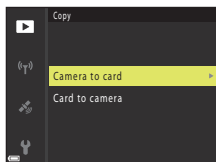

- 2 Select a copy option and press the  button.

- When you choose **Selected images**, use the image selection screen to specify images (📖 122).
- When you choose the **Card to camera** option, **All images** is not available.

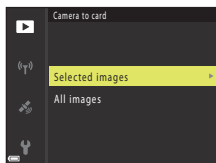

Notes About Copying Images



- Only files in formats that this camera can record can be copied.
- Operation is not guaranteed with images captured with another make of camera or that have been modified on a computer.

Copying Images in a Sequence



- If you select a key picture of a sequence in **Selected images**, all images in the sequence are copied.
- If you press the MENU button while images in a sequence are displayed, only the **Card to camera** copy option is available. All images in the sequence are copied if you select **Current sequence**.



Sequence Display

Press the  button (playback mode) → MENU button → Sequence display →  button

Select the method used to display images in the sequence (70).

Option	Description
 Individual pictures	Displays each image in a sequence individually.  is displayed on the playback screen.
 Key picture only (default setting)	Displays only the key picture for images in a sequence.

Settings are applied to all sequences, and the setting is saved in the camera's memory even after the camera is turned off.



The Network Menu

Press the MENU button → “T” menu icon → OK button

Configure the wireless network settings to connect the camera and a smart device.

- Some settings cannot be changed while a wireless connection is established. To change them, disconnect the wireless connection.

Option	Description
Airplane mode	Select On to turn off all wireless connections.
Connect to smart device	Select when using the SnapBridge app to connect the camera and a smart device. See the included “SnapBridge Connection Guide” for more information.
Send while shooting	Set the conditions for automatically sending images to a smart device. <ul style="list-style-type: none">• The size of images that are uploaded is restricted to 2 megapixels. To upload still images at their original size, use Download pictures in the SnapBridge app.
Wi-Fi	Network settings
	SSID*: Change the SSID. Set a 1- to 32-character alphanumeric SSID.
	Auth./encryp.: Select whether or not to encrypt the communications between the camera and the connected smart device. Communications are not encrypted when Open is selected.
	Password*: Set the password. Set an 8- to 36-character alphanumeric password.
	Channel: Select the channel used for wireless connections.
	Subnet mask: Use the default setting (255.255.255.0) under normal conditions.
DHCP server IP address: Use the default setting (192.168.0.10) under normal conditions.	
Current settings	Display the current settings.



Option		Description
Bluetooth	Connection	Select Disable to turn off Bluetooth communication.
	Paired devices	Change the smart device to connect with, or delete the connected smart device. This camera can be paired with up to five smart devices, but can connect to only one device at a time.
	Send while off	Set whether or not to allow the camera to communicate with the smart device when the camera is off or in standby mode (📖20).
Restore default settings		Restore all network menu settings to their default values.

* See “Operating the Text Input Keyboard” (📖156) for information on how to enter alphanumeric characters.

✔ **Notes About the Internal Memory**

- Images saved in the camera’s internal memory cannot be uploaded to a smart device. To upload images in the internal memory, use the playback menu **Copy** to copy the images to the memory card in the camera.
- You cannot perform remote photography from a smart device if a memory card is not inserted in the camera.



Operating the Text Input Keyboard

Character Input for SSID, Password, Image Comment, and Copyright Information

- Use the multi selector ▲▼◀▶ to select alphanumeric characters. Press the **OK** button to enter the selected character in the text field and move the cursor to the next space.
- To move the cursor in the text field, select ← or → on the keyboard, and press the **OK** button.
- To delete one character, press the **⌫** button.
- To apply the setting, select ↵ on the keyboard and press the **OK** button.





Character Input for Channel, Subnet Mask, and DHCP Server IP Address

- Use the multi selector ▲▼ to set the numbers. To move to the next digit, press ▶ or the **OK** button. To return to the previous digit, press ◀.
- To apply the setting, select the last digit and press the **OK** button.



The Location Data Options Menu



Location Data Options

Press the **MENU** button →  menu icon → Location data options →  button



Option	Description
Use built-in location data	When set to On , signals are received from the positioning satellites, and positioning starts (📖97). <ul style="list-style-type: none">• Default setting: Off
Download from device	Select Yes to add location data from a smart device to the images that you take. Enable the location data functions of the SnapBridge app. <ul style="list-style-type: none">• Default setting: No• When Use built-in location data is set to On and the camera is positioning, the location data functions built in the camera is prioritized.
Position	Display the obtained location data. <ul style="list-style-type: none">• The data is not updated while it is being displayed. To update it, perform Position again.
Update A-GPS file	A memory card is used to update the A-GPS (assist GPS) file. Using the latest A-GPS file can shorten the time needed to obtain the location data. <ul style="list-style-type: none">• See "Updating the A-GPS File" (📖99) for more information.
Erase location data	The location data and POI information recorded on images are erased. Before pressing the MENU button, select the images with the location data or POI information that you want to delete. <ul style="list-style-type: none">• The deleted location data or POI information cannot be recovered.• The location data of images captured with cameras other than this camera cannot be erased.



Points of Interest (POI) (Recording and Displaying Location Name Information)

Press the **MENU** button →  menu icon → Points of interest (POI) →  button

Configure the POI (points of interest, location name information) settings.



Option	Description
Embed POI	Set whether or not to record the location name information on the images to be shot. <ul style="list-style-type: none">• Default setting: Off• The location name information can be recorded on both still images and movies.
Display POI	Set whether or not to display the location name information on the screen ( 6, 7, 8). <ul style="list-style-type: none">• If Embed POI was set to On when an image was captured, the location name information for the image is displayed on the playback screen.• Default setting: Off
Level of detail	Set the display level of the location name information. A higher display level shows more detailed regional information. <ul style="list-style-type: none">• When set to level 1: country names are displayed.• When set to levels 2 to 5: the information displayed varies depending on the country.• When set to level 6: landmark names (facilities) are displayed.
Edit POI	Before pressing the MENU button, select the image to change the location name information. <ul style="list-style-type: none">• Update POI: The location name information recorded on the image can be changed.<ul style="list-style-type: none">- When level 6 is selected, press the multi selector  to change the landmark name.- To change the POI information level, press the multi selector .• Remove POI: The location name information recorded on the image is deleted.

POI Display

- If there is no location name information at the set display level, the location name information may not be displayed or "—" may be displayed.
- Location name information is not displayed when location data is being downloaded from a smart device. Also, location name information is not recorded to captured images.
- Certain landmark names may not be registered, or the landmark name may be different.



Create Log

Press the **MENU** button →  menu icon → Create log →  button

Start or stop recording logs, and save them (101).



Option	Description
Start all logs ^{1,2}	The camera records location, altitude, and water depth logs. <ul style="list-style-type: none">Log recording starts when you select a log interval and log duration.
Start location log ^{1,2}	The camera records a location log. <ul style="list-style-type: none">Log recording starts when you select a log interval and log duration.
Start depth log ¹	The camera records a water depth log. <ul style="list-style-type: none">Log recording starts when you select a log interval and log duration.

¹ Cannot be selected if there is a log that has not been saved. Select **End all logs**, **End location log**, or **End depth log**, and save or delete the log.





² Cannot be selected when **Use built-in location data** in the location data options menu is set to **Off**.





View Log

Press the **MENU** button →  menu icon → View log →  button

Check or erase the log data saved on the memory card using **Create log** (159).



Option	Description
Location logs	<p>A list of logs (dates) is displayed.</p> <ul style="list-style-type: none">Press the  (delete) button to delete the selected log or all saved location logs.
Altitude/depth logs	<p>Select a log (date) that you want to display and press the  button to display the altitude or water depth data as a graph (104).</p> <ul style="list-style-type: none">Press the  (delete) button to delete the selected log or all saved altitude/depth logs.

Set Clock from Satellite

Press the **MENU** button →  menu icon → Set clock from satellite →  button

Signals from the positioning satellites are used to set the date and time of the camera's internal clock. Check the positioning status before setting the clock using this option.



Notes About Set Clock from Satellite

- To set the camera's internal clock, positioning must have been done successfully (95).
- Date/time adjustment by **Set clock from satellite** is set according to the time zone set in **Time zone and date** (163) in the setup menu. Check the time zone before setting **Set clock from satellite**.
- The date/time set using **Set clock from satellite** is not as accurate as radio clocks. Use **Time zone and date** in the setup menu to set the time if it is not accurate when set using **Set clock from satellite**.

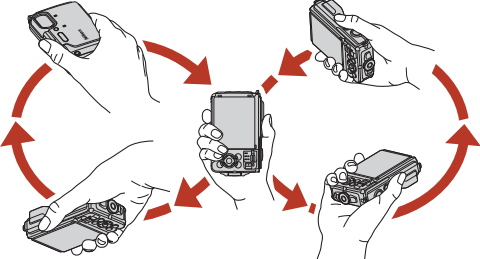

Electronic Compass

Press the **MENU** button →  menu icon → **Electronic compass** →  button



Option	Description
Compass display	<p>Set whether or not to display a compass on the shooting screen.</p> <ul style="list-style-type: none">• Default setting: Off• The direction the camera is pointing is displayed based on measured direction information.• When the camera lens faces downward, the compass display switches to a circle compass with a red arrow that points north.<ul style="list-style-type: none">- Display style: north, east, south, and west- Display range: 16 cardinal points• The direction measured by the electronic compass can be imprinted on images using Data imprint in the playback menu (76).
Compass correction	<p>Correct the compass when the compass direction is not displayed correctly.</p> <p>When the screen shown on the right is displayed, swing the camera to draw a figure eight in the air while turning your wrist to face the camera forward and backward, side to side, or up and down.</p>  







Notes About Using the Electronic Compass

See "Notes About Using the Electronic Compass" (106) for more information.



Altitude/Depth Options

Press the **MENU** button →  menu icon → Altitude/depth options →  button

Option	Description
Altimeter/depth gauge	Set whether or not to display the altimeter or depth gauge on the shooting screen. <ul style="list-style-type: none">• Default setting: On
Alt./depth correction	The altitude or water depth value is corrected. <ul style="list-style-type: none">• Use location data: The altitude is corrected using the record location data function.<ul style="list-style-type: none">- When the confirmation dialog is displayed, select Yes and press the  button. The altitude is corrected using the displayed value.- The data is not corrected underwater.• Correct manually: Enter the altitude or water depth to correct the data.<ul style="list-style-type: none">- Use the multi selector   to change the value and use   to change the input position of the digits.- When the cursor is positioned on the rightmost digit, press the  button to set this value.• Reset: The correction set using Use location data or Correct manually is canceled.<ul style="list-style-type: none">- When the correction cancellation dialog is displayed, select Yes and press the  button. The corrected value is canceled.
Altitude/depth units	Set the unit of distance for displaying altitude or water depth to m (meters) (default setting) or ft (feet).

Notes About Altitude/Depth Options

- To correct the altitude or water depth using **Use location data** in **Alt./depth correction**, **Use built-in location data** in **Location data options** in the location data options menu must be set to **On**, and also positioning must have been performed based on signals received from four or more satellites (📖95).
- When **Altimeter/depth gauge** is set to **On**, the altimeter or depth gauge, altitude or water depth, and the atmospheric pressure are displayed even if **Hide info** is selected for **Photo info** in **Monitor settings** in the setup menu (📖120).











The Setup Menu

Time Zone and Date

Press the **MENU** button →  menu icon → Time zone and date →  button

Set the camera clock.

Option	Description
Sync with smart device	Select On to synchronize the date and time setting with a smart device. Enable the clock synchronization function of the SnapBridge app.
Date and time*	<ul style="list-style-type: none">• Select a field: Press the multi selector  .• Edit the date and time: Press  .• Apply the setting: Select the minute field setting and press the  button. 
Date format	Select Year/Month/Day , Month/Day/Year , or Day/Month/Year .
Time zone*	Set time zone and daylight saving time. <ul style="list-style-type: none">• When Travel destination () is set after having set the home time zone () , the time difference between the travel destination and the home time zone is automatically calculated, and the date and time are saved for the selected region.

* Can be set only when **Sync with smart device** is set to **Off**.



Setting the Time Zone

- 1 Use the multi selector ▲▼ to select **Time zone** and press the Ⓞ button.

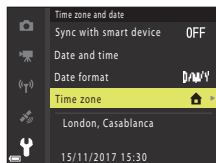

- 2 Select 🏠 **Home time zone** or 🚶 **Travel destination** and press the Ⓞ button.

- The date and time displayed on the screen changes depending on whether the home time zone or travel destination is selected.

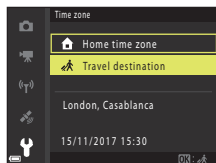

- 3 Press ▶.

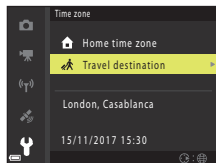

- 4 Use ◀▶ to select the time zone.

- Press ▲ to enable daylight saving time function, and ☀ is displayed. Press ▼ to disable the daylight saving time function.
- Press the Ⓞ button to apply the time zone.
- If the correct time is not displayed for the home or travel destination time zone setting, set the appropriate time in **Date and time**.

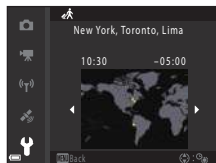





Monitor Settings



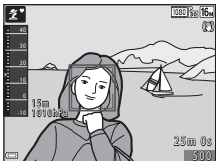

Press the MENU button →  menu icon → Monitor settings →  button

Option	Description
Photo info	Set whether or not to display information on the screen.
Help display	The descriptions of functions are displayed while changing the shooting mode or while the setting screen is displayed. <ul style="list-style-type: none"> • Default setting: On
Image review	Set whether or not to display the captured image immediately after shooting. <ul style="list-style-type: none"> • Default setting: On
Brightness	Adjust the brightness. <ul style="list-style-type: none"> • Default setting: 3

Photo Info

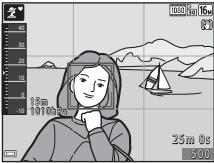
	Shooting mode	Playback mode
Show info		
Auto info (default setting)	The same information as shown in Show info is displayed, and it is hidden as shown in Hide info if no operations are performed for a few seconds. The information is displayed again when an operation is performed.	
Hide info		

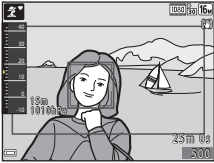

	Shooting mode	Playback mode
Framing grid+auto info	 <p>In addition to the information shown in Auto info, a framing grid is displayed to help frame pictures. The framing grid is not displayed while recording movies.</p>	 <p>Same as Auto info.</p>
Movie frame+auto info	 <p>In addition to the information shown in Auto info, a frame is displayed before movie recording begins that represents the area that will be captured when recording movies. The movie frame is not displayed while recording movies.</p>	 <p>Same as Auto info.</p>



Date Stamp

Press the **MENU** button → **Y** menu icon → Date stamp → **OK** button

The shooting date and time can be stamped on images when shooting.





Option	Description
DATE Date	Date is stamped on images.
DATE Date and time	Date and time are stamped on images.
Off (default setting)	Date and time are not stamped on images.

Notes About Date Stamp



- Stamped date and time form a permanent part of image data and cannot be deleted. The date and time cannot be stamped on images after they have been captured.
- The date and time cannot be stamped in the following situations:
 - When the scene mode is set to **Sports**, **Night portrait** (when set to **Hand-held**), **Night landscape** (when set to **Hand-held**), **Backlighting** (when **HDR** is set to **ON**), **Easy panorama**, **Pet portrait** (when set to **Continuous**), or **Multiple exp. Lighten**
 - Creative mode
 - When **Blink proof** (140) is set to **On**
 - When the continuous shooting setting (132) is set to a setting other than **Single**
 - When recording movies
 - When saving still images during movie recording
 - When creating still images by editing movies
- The stamped date and time may be difficult to read when using a small image size.



Photo VR

Press the **MENU** button →  menu icon → Photo VR →  button

Select the vibration reduction setting used when shooting still images.
Set to **Off** when using a tripod to stabilize the camera during shooting.



Option	Description
 * On (hybrid)	Performs optical compensation for camera shake using the lens shift method. Under the following conditions, also performs electronic VR using image processing. <ul style="list-style-type: none">• Flash: Does not fire• Shutter speed: Slower than 1/30 second at the maximum wide-angle position and 1/60 second at the maximum telephoto position• Self-timer: OFF• Continuous setting: Single• ISO sensitivity: ISO 200 or lower It may take more time than usual to save images after shooting.
 On (default setting)	Compensation for camera shake is performed using lens shift VR.
Off	Compensation is not performed.

Notes About Photo VR

- After turning on the camera or after switching from playback mode to shooting mode, wait until the shooting screen is ready before taking pictures.
- Images on the screen may be displayed blurry immediately after shooting.
- Vibration reduction may be unable to completely eliminate the effects of camera shake in some situations.
- When the shutter speed is extremely slow, images cannot be compensated using image processing even when **On (hybrid)** is set.





AF Assist

Press the MENU button →  menu icon → AF assist →  button

Option	Description
AUTO Auto (default setting)	The AF-assist illuminator automatically lights up when you press the shutter-release button under dim lighting. The illuminator has a range of about 3.0 m (9 ft 10 in.) at the maximum wide-angle position and about 3.0 m (9 ft 10 in.) at the maximum telephoto position. <ul style="list-style-type: none">• The AF-assist illuminator may not light depending on the position of the focus area or the shooting mode.
Off	The AF-assist illuminator does not light.

Digital Zoom

Press the MENU button →  menu icon → Digital zoom →  button

Option	Description
On (default setting)	Digital zoom is enabled.
Off	Digital zoom is disabled.

Notes About Digital Zoom

- Digital zoom cannot be used in the following shooting modes:
 - **Portrait, Night sky** and **Star trails** in **Time-lapse movie, Night portrait, Night landscape, Backlighting** (when **HDR** is set to **ON**), **Easy panorama, Pet portrait, Nightscape + star trails** and **Star trails** in **Multiple exp. Lighten**, or **Underwater scene mode**
 - Creative mode
 - Smart portrait mode
- Digital zoom cannot be used in other shooting modes when using certain settings ( 65).



Sound Settings

Press the MENU button →  menu icon → Sound settings →  button

Option	Description
Button sound	When On (default setting) is selected, the camera produces one beep when operations are performed, two beeps when focus is acquired on the subject, and three beeps when an error occurs. The welcome screen sound is also produced. <ul style="list-style-type: none">• Sounds are disabled when using Pet portrait scene mode.
Shutter sound	When On (default setting) is selected, the shutter sound is produced when the shutter is released. <ul style="list-style-type: none">• The shutter sound is not produced when recording movies or when using Pet portrait or Easy panorama scene mode.

Underwater Flash

Press the MENU button →  menu icon → Underwater flash →  button



Select **On** when shooting underwater using an SB-N10 underwater speedlight (available separately) (209). The default setting is **Off**.

Notes About Underwater Flash

This function may not be available to use in combination with other functions (64).



Action Control Response



Press the **MENU** button →  menu icon → Action control response →  button

Set the sensitivity of the operation performed when shaking the camera (action control) (📖24). When this option is set to **High**, the operation is performed even if the camera shake movement is small. When this option is set to **Low**, the operation is performed if the camera shake movement is large. The default setting is **Medium**.

✓ Notes About Action Control Response

When viewing images with **Quick playback** of action control or in full-frame playback mode, operation response of selecting images is fixed.

Playback Action Control

Press the **MENU** button →  menu icon → Playback action control →  button

Option	Description
On (default setting)	An image can be selected by shaking the camera in full-frame playback mode.
Off	The image cannot be selected by shaking the camera.

✓ Notes About Playback Action Control

When **Playback action control** is set to **On**, the displayed images are not rotated automatically even if the orientation of the camera is changed.



Auto Off

Press the **MENU** button → **Y** menu icon → Auto off → **OK** button

Set the amount of time that elapses before the camera enters standby mode (📖20). You can select **30 s**, **1 min** (default setting), **5 min**, or **30 min**.

Setting the Auto Off Function

The time that passes before the camera enters standby mode is fixed in the following situations:

- When a menu is displayed: 3 minutes (when auto off is set to **30 s** or **1 min**)
- When shooting using **Pet portrait auto release** (📖34): 5 minutes (when auto off is set to **30 s** or **1 min**)
- When shooting using **Smile timer** (📖44): 5 minutes (when auto off is set to **30 s** or **1 min**)
- When the EH-62F AC Adapter is connected: 30 minutes
- When an HDMI cable is connected: 30 minutes
- When waiting for connecting with **Connect to smart device**: 30 minutes



LED Light Timer

Press the **MENU** button → **Y** menu icon → LED light timer → **OK** button

Set the amount of time that elapses before the LED light (📖2) turns off. You can select **3 min**, **5 min** (default setting), or **10 min**.



Format Card/Format Memory

Press the **MENU** button →  menu icon → Format card/Format memory →  button

Use this option to format a memory card or the internal memory.

Formatting the memory cards or internal memory permanently deletes all data. Data that has been deleted cannot be recovered. Make sure to save important images to a computer before formatting.

Formatting a Memory Card

- Insert a memory card into the camera.
- Select **Format card** in the setup menu and then press the  button.



Formatting the Internal Memory

- Remove the memory card from the camera.
- Select **Format memory** in the setup menu and then press the  button.

To start formatting, select **Format** on the screen that is displayed and press the  button.

- Do not turn the camera off or open the battery-chamber/memory card slot cover during formatting.
- You may not be able to select this setting while a wireless connection is established.

Language

Press the **MENU** button →  menu icon → Language →  button

Select a language for display of camera menus and messages.



Image Comment

Press the **MENU** button → **Y** menu icon → **Image comment** → **OK** button

Attach a comment that was previously registered to images that will be captured. You can imprint the attached comment to images that will be sent to a smart device using the SnapBridge app. You must configure the SnapBridge app in advance. See SnapBridge app online help for more information.

Option	Description	
Attach comment	<p>A comment registered with Input comment is attached to images.</p> <ul style="list-style-type: none">• Select Attach comment, press ▶, and set the check box to on (✓). When you press the OK button, the setting is enabled, and the comment will be attached to the images captured afterwards.	
Input comment	<p>You can register a comment of up to 36 alphanumeric characters.</p> <ul style="list-style-type: none">• Select Input comment, press ▶, and the input screen is displayed. See "Operating the Text Input Keyboard" (📖156) for information about the input method.	

Image Comments Display

Image comments are not displayed even if images are played back on the camera.

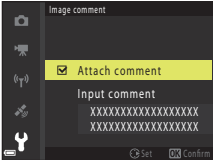

Copyright Information

Press the **MENU** button → **Y** menu icon → Copyright information → **OK** button

Attach the copyright information that was previously registered to images that will be captured.

You can imprint the attached copyright information to images that will be sent to a smart device using the SnapBridge app. You must configure the SnapBridge app in advance. See SnapBridge app online help for more information.

Option	Description
Attach copyright info	<p>Copyright information registered with Artist and Copyright is attached to images.</p> <ul style="list-style-type: none">• Select Attach copyright info, press ▶, and set the check box to on (✓). When you press the OK button, the setting is enabled, and the copyright information will be attached to the images captured afterwards.
Artist	<p>You can register an artist name of up to 36 alphanumeric characters.</p> <ul style="list-style-type: none">• Select Artist, press ▶, and the input screen is displayed. See “Operating the Text Input Keyboard” (📖156) for information about the input method.
Copyright	<p>You can register a copyright owner name of up to 54 alphanumeric characters.</p> <ul style="list-style-type: none">• Select Copyright, press ▶, and the input screen is displayed. See “Operating the Text Input Keyboard” (📖156) for information about the input method.

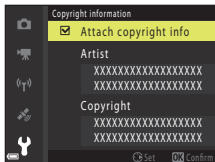

✓ Notes About Copyright Information



- To prevent illegal use of artist names and copyright owner names when lending or transferring ownership of the camera, make sure to disable the **Attach copyright info** setting. Also, make sure that the artist name and copyright owner name are blank.
- Nikon is not responsible for any kind of trouble or damage resulting from the use of **Copyright information**.

📎 Displaying Copyright Information

- Copyright information is not displayed even if images are played back on the camera.
- If you input both **Artist** and **Copyright**, only the copyright owner name is imprinted to images in the SnapBridge app.



Charge by Computer

Press the MENU button →  menu icon → Charge by computer →  button

Option	Description
AUTO Auto (default setting)	When the camera is connected to a computer that is running (📖108), the battery inserted into the camera is automatically charged using power supplied by the computer.
Off	The battery inserted into the camera is not charged when the camera is connected to a computer.

Notes About Charging with a Computer

- When connected to a computer, the camera turns on and starts charging. If the camera is turned off, charging stops.
- About 4 hours and 10 minutes are required to charge a fully exhausted battery. Charging time increases when images are transferred while the battery is charging.
- The camera turns off automatically if there is no communication with the computer for 30 minutes after the battery has finished charging.



When the Charge Lamp Quickly Flashes

Charging cannot be performed, possibly due to one of the reasons described below.

- The ambient temperature is not suited to charging. Charge the battery indoors with an ambient temperature of 5°C to 35°C (41°F to 95°F).
- The USB cable is not connected correctly or the battery is faulty. Make sure the USB cable is connected correctly or replace the battery if necessary.
- The computer is in sleep mode and is not supplying power. Wake up the computer.
- The battery cannot be charged because the computer cannot supply power to the camera due to the computer's settings or its specifications.



Reset All

Press the MENU button →  menu icon → Reset all →  button



When **Reset** is selected, the camera's settings are restored to their default values.

- Some settings, such as **Time zone and date** or **Language**, are not reset.
- You may not be able to select this setting while a wireless connection is established.

Resetting File Numbering

To reset file numbering to "0001", delete all images saved on the memory card or in the internal memory () before selecting **Reset all**.

Conformity Marking

Press the MENU button →  menu icon → Conformity marking →  button

View some of the conformity markings that the camera complies with.

Firmware Version

Press the MENU button →  menu icon → Firmware version →  button

View the current camera firmware version.

- You may not be able to select this setting while a wireless connection is established.



Technical Notes

Notices.....	179
Notes About Wireless Communication Functions	181
Notes About Location Data Functions (GPS/GLONASS, Electronic Compass)....	184
Caring for the Product.....	185
The Camera	185
The Battery	186
The Charging AC Adapter.....	187
Memory Cards.....	188
Cleaning and Storage	189
Cleaning After Using the Camera Underwater	189
Cleaning After Using the Camera in Conditions Other than Underwater ...	189
Storage	190
Error Messages	191
Troubleshooting.....	195
File Names.....	206
Optional Accessories.....	208
Attaching the Underwater Speedlight.....	209
Specifications.....	213
Memory Cards That Can Be Used.....	218
USER LICENSE AGREEMENT FOR LOCATION NAME DATA.....	220
Index	225



Notices

Notices for Customers in the U.S.A.

IMPORTANT SAFETY INSTRUCTIONS - SAVE THESE INSTRUCTIONS.

DANGER - TO REDUCE THE RISK OF FIRE OR ELECTRIC SHOCK, CAREFULLY FOLLOW THESE INSTRUCTIONS

For connection to a supply not in the U.S.A., use an attachment plug adapter of the proper configuration for the power outlet if needed.

The power supply unit is intended to be correctly orientated in a vertical or floor mount position.

Federal Communications Commission (FCC) Radio Frequency Interference Statement

This equipment has been tested and found to comply with the limits for a Class B digital device, pursuant to Part 15 of the FCC rules. These limits are designed to provide reasonable protection against harmful interference in a residential installation.

This equipment generates, uses, and can radiate radio frequency energy and, if not installed and used in accordance with the instructions, may cause harmful interference to radio communications. However, there is no guarantee that interference will not occur in a particular installation. If this equipment does cause harmful interference to radio or television reception, which can be determined by turning the equipment off and on, the user is encouraged to try to correct the interference by one or more of the following measures:

- Reorient or relocate the receiving antenna.
- Increase the separation between the equipment and receiver.
- Connect the equipment into an outlet on a circuit different from that to which the receiver is connected.
- Consult the dealer or an experienced radio/television technician for help.



CAUTIONS

Modifications

The FCC requires the user to be notified that any changes or modifications made to this device that are not expressly approved by Nikon Corporation may void the user's authority to operate the equipment.

Interface Cables

Use the interface cables sold or provided by Nikon for your equipment. Using other interface cables may exceed the limits of Class B Part 15 of the FCC rules.



Notice for Customers in Canada

CAN ICES-3 B / NMB-3 B

Notices for Customers in Europe

CAUTIONS

RISK OF EXPLOSION IF BATTERY IS REPLACED BY AN INCORRECT TYPE.

DISPOSE OF USED BATTERIES ACCORDING TO THE INSTRUCTIONS.

This symbol indicates that electrical and electronic equipment is to be collected separately.

The following apply only to users in European countries:

- This product is designated for separate collection at an appropriate collection point. Do not dispose of as household waste.
- Separate collection and recycling helps conserve natural resources and prevent negative consequences for human health and the environment that might result from incorrect disposal.
- For more information, contact the retailer or the local authorities in charge of waste management.



This symbol on the battery indicates that the battery is to be collected separately.

The following apply only to users in European countries:

- All batteries, whether marked with this symbol or not, are designated for separate collection at an appropriate collection point. Do not dispose of as household waste.
- For more information, contact the retailer or the local authorities in charge of waste management.



Notes About Wireless Communication Functions

Restrictions on Wireless Devices

The wireless transceiver included in this product conforms to wireless regulations in the country of sale and is not for use in other countries (products purchased in the EU or EFTA can be used anywhere within the EU and EFTA). Nikon does not accept liability for use in other countries. Users who are unsure as to the original country of sale should consult with their local Nikon service center or Nikon-authorized service representative. This restriction applies to wireless operation only and not to any other use of the product.

Security

Although one of the benefits of this product is that it allows others to freely connect for the wireless exchange of data anywhere within its range, the following may occur if security is not enabled:

- Data theft: Malicious third-parties may intercept wireless transmissions to steal user IDs, passwords, and other personal information.
- Unauthorized access: Unauthorized users may gain access to the network and alter data or perform other malicious actions. Note that due to the design of wireless networks, specialized attacks may allow unauthorized access even when security is enabled. Nikon is not responsible for data or information leaks that may occur during data transfer.
- Do not access networks that you are not permitted to use, even if they are displayed on your smartphone or tablet. Doing so may be regarded as unauthorized access. Only access networks that you are permitted to use.

Personal Information Management and Disclaimer

- User information registered and configured on the product, including wireless LAN connection settings and other personal information, is susceptible to alteration and loss resulting from operational error, static electricity, accident, malfunction, repair or other handling. Always keep separate copies of important information. Nikon is not responsible for any direct or indirect damages or lost profits resulting from alteration or loss of content that is not attributable to Nikon.
- Before discarding this product or transferring it to another owner, perform **Reset all** in the setup menu (📖120) to delete all user information registered and configured with the product, including wireless LAN connection settings and other personal information.
- Nikon is not responsible for any damages resulting from unauthorized use of this product by third parties in the event that the product is stolen or lost.



Precautions when Exporting or Carrying This Product Abroad

This product is controlled by the United States Export Administration Regulations (EAR). The permission of the United States government is not required for export to countries other than the following, which as of this writing are subject to embargo or special controls: Cuba, Iran, North Korea, Sudan, and Syria (list subject to change).

Notice for Customers in the U.S.A. and Canada

Federal Communications Commission (FCC) and Innovation, Science and Economic Development Canada (ISED)

Declaration of Conformity

This device complies with Part 15 of FCC Rules and Innovation, Science and Economic Development Canada's licence-exempt RSSs. Operation is subject to the following two conditions: (1) this device may not cause harmful interference, and (2) this device must accept any interference received, including interference that may cause undesired operation.

FCC/ISED RF Exposure Statement

This transmitter must not be co-located or operated in conjunction with any other antenna or transmitter.

The available scientific evidence does not show that any health problems are associated with using low power wireless devices. There is no proof, however, that these low power wireless devices are absolutely safe. Low power Wireless devices emit low levels of radio frequency energy (RF) in the microwave range while being used. Whereas high levels of RF can produce health effects (by heating tissue), exposure of low-level RF that does not produce heating effects causes no known adverse health effects. Many studies of low-level RF exposures have not found any biological effects. Some studies have suggested that some biological effects might occur, but such findings have not been confirmed by additional research. This product has been tested and found to comply with FCC/ISED radiation exposure limits set forth for an uncontrolled environment and meets the FCC radio frequency (RF) Exposure Guidelines and RSS-102 of the ISED radio frequency (RF) Exposure rules. Please refer to the SAR test report that was uploaded to FCC website.

Notice for Customers in Europe

Declaration of Conformity (Europe)

Hereby, Nikon Corporation declares that the radio equipment type COOLPIX W300 is in compliance with Directive 2014/53/EU.

The full text of the EU declaration of conformity is available at the following internet address: http://imaging.nikon.com/support/pdf/DoC_W300.pdf.

- Maximum output power: 11.3 dBm (EIRP)
- Operating frequency:
 - Wi-Fi: 2412–2462 MHz (1–11 channels)
 - Bluetooth: 2402–2480 MHz
 - Bluetooth Low Energy: 2402–2480 MHz



Notice for Customers in Singapore

This device complies with radio-frequency regulations.

**Complies with
IMDA Standards
DA103423**

Notice for Customers in Zambia

This device complies with radio-frequency regulations.



Notice for Customers in Nigeria

This device complies with radio-frequency regulations.

Connection and use of this communications
equipment is permitted by the Nigerian
Communications Commission



Notes About Location Data Functions (GPS/GLONASS, Electronic Compass)

Location name data of this camera

Before using the location data functions, make sure to read "USER LICENSE AGREEMENT FOR LOCATION NAME DATA" (📖220) and agree to the terms.

- The location name information (Points of Interest: POI) will not be updated.
- Use the location name information only as a guide.
- The location name information (Points of Interest: POI) of the People's Republic of China ("China") and the Republic of Korea is not provided for the COOLPIX W300.

Notes about record location data functions and log recording

- When **Use built-in location data** in **Location data options** in the location data options menu is set to **On** or while recording logs, record location data functions and log recording will continue to operate even after the camera is turned off (📖95).
- An individual may be identified from still images or movies that have been recorded with location data. Observe caution when you transfer still images or movies recorded with location data, or log files to a third party or upload them to a network such as the Internet where the public can view them. Make sure to read "Disposing of Data Storage Devices" (📖v).

Notes about measurement functions

The COOLPIX W300 is a camera. Do not use this camera as a navigation device or measuring instrument.

- Use information (such as direction, altitude and water depth) measured by the camera as a guideline only. Do not use this information for navigation of an airplane, car, and person or land survey applications.
- When you use the camera for mountain climbing, trekking, or underwater, make sure to take a map, navigation device, or measuring instrument separately.

Using the camera overseas

- Before taking the camera with location data functions overseas for travel, consult your travel agency or embassy of the country you are visiting to confirm whether there is any restriction on use.
For example, you cannot record location data logs without permission from the government in China.
Set **Use built-in location data** to **Off**.
- The location data may not function properly in China and on the borders between China and neighboring countries (as of December 2014).



Caring for the Product

Observe the precautions described below in addition to the warnings in “For Your Safety” (📖vi–viii) and “<Important> Notes About Shockproof, Waterproof, and Dustproof Performance and Condensation” (📖ix) when using or storing the device.

The Camera

Do Not Apply Strong Impact to the Camera

The product may malfunction if subjected to strong shock or vibration. In addition, do not touch or apply force to the lens.

Avoid Sudden Changes in Temperature

Sudden changes in temperature, such as when entering or leaving a heated building on a cold day, can cause condensation to form inside the device. To prevent condensation, place the device in a carrying case or a plastic bag before exposing it to sudden changes in temperature.

Keep Away from Strong Magnetic Fields

Do not use or store this device in the vicinity of equipment that generates strong electromagnetic radiation or magnetic fields. Doing so could result in loss of data or camera malfunction.

Do Not Point the Lens at Strong Light Sources for Extended Periods

Avoid pointing the lens at the sun or other strong light sources for extended periods when using or storing the camera. Intense light may cause the image sensor to deteriorate or produce a white blur effect in photographs.

Turn the Product Off Before Removing or Disconnecting the Power Source or Memory Card

Do not remove the battery while the product is on, or while images are being saved or deleted. Forcibly cutting power in these circumstances could result in loss of data or in damage to the memory card or internal circuitry.

Notes About the Monitor

- Monitors (including electronic viewfinders) are constructed with extremely high precision; at least 99.99% of pixels are effective, with no more than 0.01% being missing or defective. Hence while these displays may contain pixels that are always lit (white, red, blue, or green) or always off (black), this is not a malfunction and has no effect on images recorded with the device.
- Images in the monitor may be difficult to see under bright lighting.
- Do not apply pressure to the monitor, as this could cause damage or malfunction. Should the monitor break, care should be taken to avoid injury caused by broken glass and to prevent the liquid crystal from the display touching the skin or entering the eyes or mouth.



The Battery

Precautions for Use

- Note that the battery may become hot after use.
- Do not use the battery at ambient temperatures below -10°C (-14°F) or above 40°C (104°F) as this could cause damage or malfunction.
- If you notice any abnormalities such as excessive heat, smoke, or an unusual smell coming from the battery, immediately discontinue use and consult your retailer or Nikon-authorized service representative.
- After removing the battery from the camera or optional battery charger, put the battery in a plastic bag, etc. in order to insulate it.

Charging the Battery

Check the battery level before using the camera and replace or charge the battery if necessary.

- Charge the battery indoors with an ambient temperature of 5°C to 35°C (41°F to 95°F) before use.
- A high battery temperature may prevent the battery from charging properly or completely, and may reduce battery performance. Note that the battery may become hot after use; wait for the battery to cool before charging.
When charging the battery inserted into this camera using the Charging AC Adapter or a computer, the battery is not charged at battery temperatures below 0°C (32°F) or above 45°C (113°F).
- Do not continue charging once the battery is fully charged as this will result in reduced battery performance.
- The battery temperature may increase during charging. However, this is not a malfunction.

Carrying Spare Batteries

Whenever possible, carry fully charged spare batteries when taking pictures on important occasions.

Using the Battery When Cold

On cold days, the capacity of batteries tends to decrease. If an exhausted battery is used at a low temperature, the camera may not turn on. Keep spare batteries in a warm place and exchange as necessary. Once warmed, a cold battery may recover some of its charge.

Battery Terminals

Dirt on the battery terminals may prevent the camera from functioning. Should the battery terminals become dirty, wipe them off with a clean, dry cloth before use.



Charging an Exhausted Battery

Turning the camera on or off while an exhausted battery is inserted in the camera may result in reduced battery life. Charge the exhausted battery before use.

Storing the Battery

- Always remove the battery from the camera or optional battery charger when it is not being used. Minute amounts of current are drawn from the battery while it is in the camera, even when not in use. This may result in excessive battery drain and complete loss of function.
- Recharge the battery at least once every six months and completely exhaust it before returning it to storage.
- Put the battery in a plastic bag, etc. in order to insulate it and store it in a cool place. The battery should be stored in a dry location with an ambient temperature of 15°C to 25°C (59°F to 77°F). Do not store the battery in hot or extremely cold locations.

Battery Life

A marked drop in the time a fully charged battery retains its charge, when used at room temperature, indicates that the battery needs to be replaced. Purchase a new battery.

Recycling Used Batteries

Replace the battery when it no longer holds a charge. Used batteries are a valuable resource. Please recycle used batteries in accordance with local regulations.

The Charging AC Adapter

- The EH-73P/EH-73PCH Charging AC Adapter is for use only with compatible devices. Do not use with another make or model of device.
- Do not use any USB cable other than the UC-E21. Using a USB cable other than the UC-E21 could result in overheating, fire or electric shock.
- Do not, under any circumstances, use another make or model of AC adapter other than the EH-73P/EH-73PCH Charging AC Adapter, and do not use a commercially available USB-AC adapter or a battery charger for a mobile phone. Failure to observe this precaution could result in overheating or in damage to the camera.
- The EH-73P/EH-73PCH is compatible with AC 100–240 V, 50/60 Hz electrical outlets. When using in other countries, use a plug adapter (commercially available) as necessary. For more information about plug adapters, consult your travel agency.



Memory Cards

Precautions for Use

- Use only Secure Digital memory cards (📄218).
- Be sure to follow the precautions described in the documentation included with the memory card.
- Do not put labels or stickers on memory cards.

Formatting

- Do not format the memory card using a computer.
- The first time you insert a memory card that has been used in another device into this camera, be sure to format it with this camera. We recommend formatting new memory cards with this camera before using them with this camera.
- **Note that formatting a memory card permanently deletes all images and other data on the memory card.** Be sure to make copies of any images you wish to keep before formatting the memory card.
- If the message **Card is not formatted. Format card?** is displayed when the camera is turned on, the memory card must be formatted. If there is data that you do not want to delete, select **No**. Copy the necessary data to a computer, etc. If you want to format the memory card, select **Yes**. The confirmation dialog will be displayed. To start formatting, press the  button.
- Do not perform the following during formatting, while data is being written to or deleted from the memory card, or during data transfer to a computer. Failure to observe this precaution could result in the loss of data or in damage to the camera or memory card:
 - Open the battery-chamber/memory card slot cover to remove/insert the battery or memory card.
 - Turn off the camera.
 - Disconnect the AC adapter.



Cleaning and Storage

Cleaning After Using the Camera Underwater

Follow the procedure below to rinse the camera with fresh water within 60 minutes after using it underwater or at the beach.

1. Keep the battery-chamber/memory card slot cover closed and wash off the camera with fresh water.

Immerse the camera in a shallow basin filled with fresh water for 10 minutes.

- Immerse the camera in fresh water and shake it sufficiently in the water to remove any foreign substances from the camera.
- When the camera is immersed in the water, a few air bubbles may come out from the water drain holes of the camera such as openings in the microphone or speakers. This is not a malfunction.

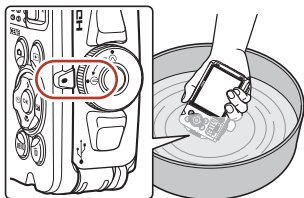

2. Wipe off water droplets with a soft cloth and dry the camera in a well-ventilated and shady place.

- Place the camera on a dry cloth to dry it.
- Do not dry the camera with hot air from a hair dryer or clothes dryer.

3. After making sure that there are no water droplets on the camera, open the battery-chamber/memory card slot cover and use a soft dry cloth to gently wipe off any water or sand remaining on the waterproof packing or inside the camera.

- If the cover is closed when the inside is wet, this could cause condensation or a malfunction.

Cleaning After Using the Camera in Conditions Other than Underwater

Use a blower to remove any dust or lint that adheres to the lens, monitor, or camera body. To remove fingerprints or other stains that cannot be removed with a blower, gently wipe the parts with a soft dry cloth. If you wipe with too much pressure or with a rough cloth, it may damage the camera or cause a malfunction.



Storage

If you do not intend to use the camera for an extended period, remove the battery and avoid storing the camera in any of the following types of locations:

- Places that are poorly ventilated or subject to humidity of over 60%
- Places exposed to temperatures above 50°C (122°F) or below -10°C (14°F)
- Places next to equipment that produces strong electromagnetic fields, such as televisions or radios

To prevent mold or mildew, take the camera out of storage at least once a month, and turn it on and release the shutter a few times before putting it away again. Completely exhaust the battery before storing it, and recharge it at least once every six months. Also, place the battery in a container such as plastic bag in order to insulate it, and store it in a cool place.





Error Messages

Refer to the table below if an error message is displayed.

Display	Cause/Solution	
Battery temperature is elevated. The camera will turn off.	The camera turns off automatically. Wait until the camera or battery temperature has cooled before resuming use.	-
The camera will turn off to prevent overheating.		
The battery is cold. Frame size/rate set to 1080/30p.	The battery temperature is below 0°C (32°F). If you want to continue recording movies with the size/frame rate set to 2160/30p (4K UHD), 2160/25p (4K UHD), 1080/60p , 1080/50p , 480/120p HS 480/4x , 480/120p HS 480/4x , 1080/120p HS 1080/0.5x , or 1080/120p HS 1080/0.5x , remove the battery from the camera and warm it up with your palms, etc. before use.	82
The battery is cold. Frame size/rate set to 1080/25p.		
The battery is cold, limiting access to some features.		
Battery exhausted.	<ul style="list-style-type: none"> • Charge the battery. • The battery temperature went below 0°C (32°F) while recording movies with the size/frame rate set to 2160/30p (4K UHD), 2160/25p (4K UHD), 1080/60p, 1080/50p, 480/120p HS 480/4x, 480/120p HS 480/4x, 1080/120p HS 1080/0.5x, or 1080/120p HS 1080/0.5x. The camera stops recording and automatically turns off. To continue recording, change the movie options. If you want to continue recording movies with the size/frame rate set to 2160/30p (4K UHD), 2160/25p (4K UHD), 1080/60p, 1080/50p, 480/120p HS 480/4x, 480/120p HS 480/4x, 1080/120p HS 1080/0.5x, or 1080/120p HS 1080/0.5x, remove the battery from the camera and warm it up with your palms, etc. before use. 	11, 13, 186 82
Memory card is write protected.	The write-protect switch is locked. Unlock it.	-
This card cannot be used.	An error occurred while accessing the memory card. <ul style="list-style-type: none"> • Use an approved memory card. • Check that the terminals are clean. • Confirm that the memory card is correctly inserted. 	11, 218
This card cannot be read.		











Display	Cause/Solution	
Card is not formatted. Format card?	The memory card has not been formatted for use in the camera. Formatting deletes all data saved on the memory card. If you need to keep copies of any images, make sure to select No and save the copies to a computer or other medium before formatting the memory card. Select Yes and press the  button to format the memory card.	188
Out of memory.	Delete images or insert a new memory card.	11, 22
Image cannot be saved.	An error occurred while saving the image. Insert a new memory card or format the memory card or internal memory.	173
	The camera has run out of file numbers. Insert a new memory card or format the memory card or internal memory.	173
	There is insufficient space to save the copy. Delete images from the destination.	22
Save previously recorded data as a time-lapse movie?	The camera turned off while recording a time-lapse movie. <ul style="list-style-type: none"> • Select Yes to create a time-lapse movie with the previously captured images. • Select No to delete the incomplete data. 	–
Image cannot be modified.	Check that the images can be edited.	72, 200
Cannot record movie.	A time-out error occurred while saving the movie on the memory card. Select a memory card with a faster write speed.	82, 218
Memory contains no images.	There are no images in the internal memory or on the memory card. <ul style="list-style-type: none"> • Remove the memory card to play back images in the internal memory. • To copy the images saved in the camera's internal memory to the memory card, press the MENU button to select Copy in the playback menu. 	12 152
	File contains no image data.	The file was not created or edited with this camera. The file cannot be viewed on this camera. View the file using a computer or the device used to create or edit this file.
All images are hidden.	There are no images available for a slide show, etc.	150



Display	Cause/Solution	
This image cannot be deleted.	The image is protected. Disable protection.	151
Failed to set clock from satellite.	The camera clock was not set correctly. Change the location or time and determine the location again.	–
No A-GPS file found on card.	An A-GPS file that can be updated is not found on the memory card. Check the following items: <ul style="list-style-type: none"> • Whether the memory card is inserted • Whether the A-GPS file is saved on the memory card • Whether the A-GPS file saved on the memory card is more recent than the A-GPS file saved in the camera • Whether the A-GPS file is still valid 	–
Update failed.	Unable to update A-GPS file. The A-GPS file may be corrupted. Download the file from the website once more.	99
Cannot save to card.	A memory card is not inserted. Insert a memory card.	11
	No log data can be recorded.	103
	The maximum number of log data events that can be saved per day has been exceeded. <ul style="list-style-type: none"> • Location logs: Up to 36 log data events per day • Altitude and water depth logs: Up to 34 log data events each per day 	207
	The maximum number of log data events that can be saved in one memory card has been exceeded. <ul style="list-style-type: none"> • Location logs: Up to 100 log data events • Altitude log and water depth log: Combined total of up to 100 log data events Replace the memory card with a new one or delete log data that is no longer required from the memory card.	103, 207
Unable to correct compass.	The camera is unable to calibrate the electronic compass. Swing the camera to draw a figure eight in the air outdoors while turning your wrist to face the camera forward and backward, side to side, or up and down.	161
Turn the camera off and then on again.	If the error persists, contact your retailer or Nikon-authorized service representative.	195



Display	Cause/Solution	
Communications error	An error occurred while communicating with the printer. Turn the camera off and reconnect the USB cable.	111
System error	An error occurred in the camera's internal circuitry. Turn the camera off, remove and reinsert the battery, and turn the camera on. If the error persists, contact your retailer or Nikon-authorized service representative.	195
Printer error: check printer status.	After solving the problem, select Resume and press the  button to resume printing.*	–
Printer error: check paper.	Load the specified size of paper, select Resume , and press the  button to resume printing.*	–
Printer error: paper jam.	Remove the jammed paper, select Resume , and press the  button to resume printing.*	–
Printer error: out of paper.	Load the specified size of paper, select Resume , and press the  button to resume printing.*	–
Printer error: check ink.	There is a problem with the printer's ink. Check the ink, select Resume , and press the  button to resume printing.*	–
Printer error: out of ink.	Replace the ink cartridge, select Resume , and press the  button to resume printing.*	–
Printer error: file corrupt.	There is a problem with the image file to be printed. Select Cancel and press the  button to cancel printing.	–

* See the documentation provided with your printer for further guidance and information.







Troubleshooting

If the camera fails to function as expected, check the list of common problems below before consulting your retailer or Nikon-authorized service representative.

Power, Display, Settings Issues

Problem	Cause/Solution	
The camera is on but does not respond.	<ul style="list-style-type: none"> • Wait for recording to end. • If the problem persists, turn the camera off. If the camera does not turn off, remove and reinsert the battery or batteries or, if you are using an AC adapter, disconnect and reconnect the AC adapter. Note that although any data currently being recorded will be lost, data that have already been recorded will not be affected by removing or disconnecting the power source. 	–
The camera cannot be turned on.	<ul style="list-style-type: none"> • The battery is exhausted. • The power switch is enabled a few seconds after the battery is inserted. Wait a few seconds before pressing the power switch. 	11, 13, 186 –
The camera turns off without warning.	<ul style="list-style-type: none"> • The camera automatically turns off to save power (auto off function). • The camera and battery may not work properly at low temperatures. • If the size/frame rate of the movie is set to 2160/30p (4K UHD), 2160/25p (4K UHD), 1080/60p, 1080/50p, 480/120 HS 480/4x, 480/120 HS 480/4x, 1080/120 HS 1080/0.5x, or 1080/120 HS 1080/0.5x and the battery temperature goes below 0°C (32°F) while recording, the camera stops recording and turns off automatically. • The inside of the camera has become hot. Leave the camera off until the inside of the camera has cooled, and then try turning it on again. 	20 186 – –
The monitor is blank.	<ul style="list-style-type: none"> • The camera is off. • The camera automatically turns off to save power (auto off function). • The camera is connected to a TV or computer. • The camera is shooting in Time-lapse movie or Multiple exp. Lighten scene mode. 	15 20 – –
The camera becomes hot.	The camera may become hot when used for an extended period of time such as to shoot movies, or when used in a hot environment; this is not a malfunction.	–





Problem	Cause/Solution	
The battery inserted in the camera cannot be charged.	<ul style="list-style-type: none"> • Confirm all connections. • When connected to a computer, the camera may not charge for any of the reasons described below. <ul style="list-style-type: none"> - Off is selected for Charge by computer in the setup menu. - Battery charging stops if the camera is turned off. - Battery charging is not possible if the camera's display language and date and time have not been set, or the date and time were reset after the camera's clock battery was exhausted. Use the Charging AC Adapter to charge the battery. - Battery charging may stop when the computer enters sleep mode. - Depending on the computer specifications, settings, and status, battery charging may not be possible. 	13 120, 176 – 15 – –
The LED light does not turn on.	<ul style="list-style-type: none"> • The battery is exhausted. • Disconnect the HDMI cable or USB cable. 	11, 13, 186 109
The LED light suddenly turns off.	<ul style="list-style-type: none"> • The LED light timer function was on. • The battery is exhausted. • If the LED light turns off after movie recording starts, set Movie light to On, or press and hold down the  (LED light) button. 	172 11, 13, 186 20, 147
The monitor is hard to see.	<ul style="list-style-type: none"> • The surroundings are too bright. <ul style="list-style-type: none"> - Move to a darker place. • Adjust the screen brightness. 	– 165
<p> flashes on the screen.</p> <p>Date and time of recording are not correct.</p>	<ul style="list-style-type: none"> • If the camera clock has not been set,  flashes on the shooting screen, and images and movies saved before the clock is set are dated "00/00/0000 00:00" and "01/01/2017 00:00" respectively. Set the correct time and date for Time zone and date in the setup menu. • The camera clock is not as accurate as ordinary watches or clocks. Periodically compare the time of the camera clock with that of a more accurate timepiece and reset as required. 	4, 163
No information displayed on the screen.	Hide info is selected for Photo info in Monitor settings in the setup menu.	165
Date stamp not available.	Time zone and date has not been set in the setup menu.	163













Problem	Cause/Solution	
Date not stamped on images even when Date stamp is enabled.	<ul style="list-style-type: none"> The current shooting mode does not support Date stamp. The date cannot be stamped on movies. 	167
Screen for setting time zone and date is displayed when the camera is turned on.	<p>The clock battery is exhausted; all settings were restored to their default values. Configure the camera settings again.</p> <ul style="list-style-type: none"> The internal clock battery is used to power the camera clock and to retain certain settings. Charging time of the clock battery takes about 10 hours when you insert the battery into the camera or connect the AC adapter (available separately) to the camera, and the clock battery operates for several days even after the camera battery is removed. 	-
The camera settings reset.		
The camera makes sound.	When Autofocus mode is set to Full-time AF or while in some shooting modes, the camera may produce an audible focusing sound.	26, 138, 146







Shooting Issues

Problem	Cause/Solution	
Cannot switch to shooting mode.	Disconnect the HDMI cable or USB cable.	109
Cannot take pictures or record movies.	<ul style="list-style-type: none"> When the camera is in playback mode, press the  button, shutter-release button, or  button. When menus are displayed, press the MENU button. The flash is charging while the flash lamp is flashing. The battery is exhausted. 	2, 21
		120 50
The camera cannot focus.	<ul style="list-style-type: none"> The subject is too close. Try shooting using scene auto selector mode, Close-up scene mode, or macro mode. The subject is hard to focus on. Turn on the LED light. Set AF assist in the setup menu to Auto. Turn the camera off and then on again. 	11, 13, 186
		26, 28, 32, 49, 54 60 20 169 -



Problem	Cause/Solution	
Images are blurred.	<ul style="list-style-type: none"> Use the flash. Increase the ISO sensitivity value. Enable Photo VR when shooting still images. Enable Movie VR when recording movies. Use a tripod to stabilize the camera (using the self-timer at the same time is more effective). 	50 134 147, 168 52
Bright specks appear in images captured with flash.	The flash is reflecting off particles in the air. Set the flash mode setting to  (off).	50
Flash does not fire.	<ul style="list-style-type: none"> The flash mode is set to  (off). A scene mode that restricts the flash is selected. A function that restricts the flash is enabled. 	50 62 64
Digital zoom cannot be used.	<ul style="list-style-type: none"> Digital zoom is set to Off in the setup menu. Digital zoom cannot be used with certain shooting modes. 	169 65, 169
Image mode not available.	A function that restricts Image mode is enabled.	64
Movie options not available.	The battery temperature is below 0°C (32°F). If you want to continue recording movies with the size/frame rate set to  2160/30p (4K UHD),  2160/25p (4K UHD),  1080/60p ,  1080/50p ,  HS 480/4x ,  HS 480/4x ,  HS 1080/0.5x , or  HS 1080/0.5x , remove the battery from the camera and warm it up with your palms, etc. before use.	82
No sound when the shutter is released.	Off is selected for Shutter sound in Sound settings in the setup menu. No sound is produced with some shooting modes, even when On is selected.	170
AF-assist illuminator does not light.	Off is selected for the AF assist option in the setup menu. AF-assist illuminator may not light depending on the position of the focus area or shooting mode, even when Auto is selected.	169
Images appear smeared.	The lens is dirty. Clean the lens.	189
Colors are unnatural.	White balance or hue is not adjusted properly.	32, 47, 130





Problem	Cause/Solution	
Randomly spaced bright pixels ("noise") appear in image.	The subject is dark and the shutter speed is too slow or ISO sensitivity is too high. Noise can be reduced by: <ul style="list-style-type: none"> Using the flash Specifying a lower ISO sensitivity setting 	50 134
Images are too dark (underexposed).	<ul style="list-style-type: none"> The flash mode is set to  (off). The flash window is blocked. The subject is beyond the range of the flash. Adjust exposure compensation. Increase ISO sensitivity. The subject is backlit. Select Backlighting scene mode or set the flash mode setting to  (fill flash). 	50 18 214 55 134 33, 50
Images are too bright (overexposed).	Adjust exposure compensation.	55
Unexpected results when flash set to  (auto with red-eye reduction).	Use any shooting mode other than Night portrait , and change the flash mode to any setting other than  (auto with red-eye reduction) and try taking the picture again.	50, 62
Skin tones are not softened.	<ul style="list-style-type: none"> Under some shooting conditions, facial skin tones may not be softened. For images containing four or more faces, try using Skin softening in Glamour retouch in the playback menu. 	43 75
Saving images takes time.	It may take more time to save images in the following situations: <ul style="list-style-type: none"> When the noise reduction function is in operation, such as when shooting in a dark environment When the flash mode is set to  (auto with red-eye reduction) When capturing images in the following scene modes: <ul style="list-style-type: none"> Hand-held in Night portrait Hand-held in Night landscape HDR is set to ON in Backlighting Easy panorama When the skin softening function is applied while shooting When using continuous shooting mode 	– 51 31 32 33 37 43 132
A ring-shaped belt or rainbow-colored stripe appears on the screen or images.	When shooting with backlighting or when a very strong light source (such as sunlight) is in the frame, a ring-shaped belt or rainbow-colored stripe (ghosting) may occur. Change the position of the light source, or frame the picture so that the light source does not enter the frame, and try again.	–



Playback Issues

Problem	Cause/Solution	
File cannot be played back.	<ul style="list-style-type: none"> This camera may not be able to play back images saved with another make or model of digital camera. This camera cannot play back movies recorded with another make or model of digital camera. This camera may not be able to play back data edited on a computer. 	–
Cannot zoom in on image.	<ul style="list-style-type: none"> Playback zoom cannot be used with movies. When zooming in on a small-sized image, the zoom ratio shown on the screen may differ from the actual zoom ratio of the image. This camera may not be able to zoom in on images captured with another make or model of digital camera. 	–
Cannot edit image.	<ul style="list-style-type: none"> Some images cannot be edited. Images that have already been edited may not be edited again. There is not enough free space on the memory card or in the internal memory. This camera is unable to edit images captured with other cameras. Editing functions used for images are not available for movies. 	39, 72 – – –
Cannot rotate image.	<ul style="list-style-type: none"> This camera cannot rotate images captured with another make or model of digital camera. Images edited using Data imprint cannot be rotated. 	– 76

Location Data Functions

Problem	Cause/Solution	
Unable to identify the location or it takes time to identify the location.	<ul style="list-style-type: none"> The camera may not be able to identify the location in some shooting environments. To use the location data functions, use the camera as much as possible in an open-air area. When positioning is performed for the first time, when positioning cannot be performed for about two hours, it takes a few minutes to obtain the location data. 	98
Unable to record location data on shot images.	When  or  is displayed on the shooting screen, the location data is not recorded. Before shooting images, check the location data reception.	95
Difference between the actual shooting location and recorded location data.	The obtained location data may deviate in some shooting environments. When there is a significant difference in the signals from the positioning satellites, there could be a deviation of up to several hundred meters.	98





Problem	Cause/Solution	
The recorded location name is different from the intended one or is not displayed.	The desired landmark name may not be registered, or a different landmark name may be registered.	–
Unable to update the A-GPS file.	<ul style="list-style-type: none"> • Check the following items: <ul style="list-style-type: none"> - Whether the memory card is inserted - Whether the A-GPS file is saved on the memory card - Whether the A-GPS file saved on the memory card is more recent than the A-GPS file saved in the camera - Whether the A-GPS file is still valid • The A-GPS file may be corrupted. Download the file from the website once more. 	– 99
Unable to turn off the altimeter or depth gauge.	When On is selected for Altimeter/depth gauge in Altitude/depth options in the location data options menu, the altimeter or depth gauge is always displayed regardless of Monitor settings in the setup menu. To turn off the altimeter or depth gauge, set the Altimeter/depth gauge to Off .	162
The altitude/water depth and atmospheric pressure icons remain displayed on the shooting screen.	Hide info is selected for Photo info in Monitor settings in the setup menu.	165
Unable to display the altimeter or depth gauge even when Altimeter/depth gauge is set to On .	<p>Even when Altimeter/depth gauge is set to On, the altimeter or depth gauge is not displayed in the following situations:</p> <ul style="list-style-type: none"> • When the shutter-release button is pressed halfway • During shooting in the Easy panorama scene mode • Creative mode • During movie recording • When a subject is registered using Subject tracking in AF area mode • When a message is being displayed 	– 37 40 80 135 –
Water depth shows 0 m	The water depth will be displayed as 0 m if the camera is not submerged underwater when the Underwater scene mode is selected.	36
Unable to select Use location data of Alt./depth correction in the location data options menu.	<ul style="list-style-type: none"> • Off is selected for Use built-in location data in the location data options menu. • This function cannot be selected unless signals are received from four or more satellites and positioning has been performed. • The camera is submerged underwater. This function cannot be selected during underwater shooting. 	157 95 –





Problem	Cause/Solution	
Unable to select Create log in the location data options menu.	The camera clock has not been set. Set date and time.	163
Unable to select Start all logs or Start location log .	<ul style="list-style-type: none"> • Off is selected for Use built-in location data in the location data options menu. • The camera is recording log data. To record a new log, select End all logs or End location log, and end the log currently being recorded. 	157 103, 159
Unable to save log data.	<ul style="list-style-type: none"> • Make sure that a memory card is inserted in the camera. • Up to 36 log data events for location logs can be recorded per day whereas up to 34 log data events each for altitude logs and water depth logs can be recorded per day. • The total number of log data events that can be saved on a single memory card is 200, which includes up to 100 log data events for location logs and up to 100 log data events for a combined total of altitude logs and water depth logs. Delete log data that is no longer required from a memory card or replace the memory card with a new one. 	11, 103, 207
Unable to select Set clock from satellite in the location data options menu.	Off is selected for Use built-in location data in the location data options menu.	157



External Device Issues

Problem	Cause/Solution	
<p>Cannot establish a wireless connection with a smart device.*</p>	<ul style="list-style-type: none"> • When establishing a wireless connection for the first time, follow the instructions in the included “SnapBridge Connection Guide” and connect. • If a wireless connection is established, perform the following operations. <ul style="list-style-type: none"> - Turn the camera off and then on again. - Restart the SnapBridge app. - Cancel the connection and then establish a connection again. • Check the Network menu settings in the camera. <ul style="list-style-type: none"> - Set Airplane mode to Off. - Set Bluetooth → Connection to Enable. • If the camera is registered with two or more smart devices, select the smart device you want to connect in Network menu → Bluetooth → Paired devices in the camera. If two or more cameras are registered in the SnapBridge app, switch the connection on the app. • Use a sufficiently charged battery. • Insert a memory card with sufficient free space into the camera. • Disconnect the HDMI cable or USB cable. • Enable Bluetooth, Wi-Fi, and the location data functions on the smart device. • In the  tab of the SnapBridge app → Auto link options → turn on Auto link. If it is off, Download pictures and Remote photography can be used, but images cannot be downloaded automatically. 	<p>–</p> <p>–</p> <p>154</p> <p>155</p> <p>–</p> <p>11</p> <p>109</p> <p>–</p> <p>–</p>



Problem	Cause/Solution	
<p>Cannot upload images to a smart device that has a wireless connection established with the SnapBridge app.*</p>	<ul style="list-style-type: none"> • Perform the operations described below when uploading automatically. <ul style="list-style-type: none"> - Set Network menu → Send while shooting → Still images in the camera to Yes. - In the  tab of the SnapBridge app → Auto link options → turn on Auto link. - In the  tab of the SnapBridge app → Auto link options → turn on Auto download. - If Network menu → Bluetooth → Send while off in the camera is set to Off, turn on the camera or change the setting to On. • When there is a large number of images to upload during Bluetooth communication, communication may be disconnected while uploading images. If you turn off the LED light and turn the camera off and then on again, the camera is reconnected to the smart device and image upload resumes in Send while shooting or Mark for upload. • Insert a memory card into the camera. Images saved in the internal memory cannot be uploaded. • You may not be able to upload images or uploading may be canceled while the camera is being operated. 	<p>154</p> <p>–</p> <p>–</p> <p>155</p> <p>–</p> <p>11, 155</p> <p>–</p>
<p>Cannot perform remote photography from a smart device that has a wireless connection established with the SnapBridge app.*</p>	<ul style="list-style-type: none"> • Remote photography cannot be performed when a memory card is not inserted into the camera. Insert a memory card. • You may not be able to perform remote photography while the camera is being operated. 	<p>155</p> <p>–</p>
<p>Cannot download still images at the original size in the SnapBridge app.*</p>	<p>For Send while shooting and Mark for upload in the camera, the size of images that are downloaded is restricted to 2 megapixels. To download still images at their original size, use Download pictures in the SnapBridge app.</p>	<p>–</p>
<p>Images saved in the camera are not displayed on a connected smart device or computer.</p>	<p>If the number of images saved on a memory card in the camera exceeds 10,000, images captured thereafter may not be displayed in a connected device.</p> <ul style="list-style-type: none"> • Reduce the number of images saved on the memory card. Copy the necessary images to a computer, etc. 	<p>–</p>



Problem	Cause/Solution	
Images are not displayed on TV.	<ul style="list-style-type: none"> • A computer or printer is connected to the camera. • The memory card contains no images. • Remove the memory card to play back images in the internal memory. 	<p>– – 12</p>
Nikon Transfer 2 does not start when the camera is connected to a computer.	<ul style="list-style-type: none"> • The camera is off. • The battery is exhausted. • The USB cable is not correctly connected. • The camera is not recognized by the computer. • The computer is not set to start Nikon Transfer 2 automatically. For more information about Nikon Transfer 2, refer to help information contained in NX Studio. 	<p>– 109, 176 109, 115 – –</p>
The PictBridge screen is not displayed when the camera is connected to a printer.	<p>With some PictBridge-compatible printers, the PictBridge startup screen may not be displayed and it may be impossible to print images when Auto is selected for Charge by computer in the setup menu. Set Charge by computer to Off and reconnect the camera to the printer.</p>	<p>120, 176</p>
Images to be printed are not displayed.	<ul style="list-style-type: none"> • The memory card contains no images. • Remove the memory card to print images in the internal memory. 	<p>– 12</p>
Cannot select paper size with the camera.	<p>The camera cannot be used to select the paper size in the following situations, even when printing from a PictBridge-compatible printer. Use the printer to select the paper size.</p> <ul style="list-style-type: none"> • The printer does not support the paper sizes specified by the camera. • The printer automatically selects the paper size. 	<p>–</p>

* See the included “SnapBridge Connection Guide” and SnapBridge online help.



File Names

Images or movies are assigned file names as follows.

File name: DSCN0001.JPG

(1) (2) (3)

(1) Identifier	Not shown on the screen of the camera. <ul style="list-style-type: none">• DSCN: Original still images, movies, still images created by the movie editing function• SSCN: Small picture copies• RSCN: Cropped copies• FSCN: Images created by an image editing function other than crop and small picture, movies created by the movie editing function
(2) File number	Assigned in ascending order, starting with "0001" and ending with "9999."
(3) Extension	Indicates file format. <ul style="list-style-type: none">• .JPG: Still images• .MP4: Movies



Log Data Saved on Memory Cards

The log data is saved in the "NCFL" folder.

File name : **N171115 0 .LOG**

(1) (2) (3)

(1) Date	Date (last two digits of the year, and the month and day in YYMMDD format) on which the log recording was started is assigned automatically.	
(2) Identification number	To manage log data events that are recorded on the same date, ID numbers are assigned automatically in an ascending order, starting from "0", in the order in which they are recorded. <ul style="list-style-type: none">• Location logs: A total of 36 alphanumeric characters consisting of the numbers 0 to 9 or the letters A to Z.• Altitude/water depth logs: A total of 34 alphanumeric characters consisting of the numbers 0 to 9 or the letters A to Z except I and O.	
(3) Extension	Signifies the file type	
	.LOG	Location logs
	.LGA	Altitude logs
	.LGB	Water depth logs

- Location logs: Up to 36 files can be recorded a day and up to 100 files can be recorded on a memory card.
- Altitude/water depth logs: Up to 34 files can be recorded each per day and a combined total of 100 files can be recorded on a memory card.

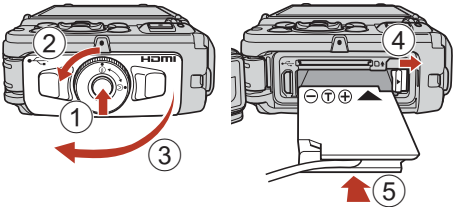

Optional Accessories

Battery charger	MH-65 Battery Charger Charging time is about 2 hours and 30 minutes for a fully exhausted battery.
AC adapter	EH-62F AC Adapter (connect as shown)  <p>Make sure that the power connector cable is fully inserted in the power connector slot before inserting the AC adapter into the battery chamber.</p> <ul style="list-style-type: none">• While using the AC adapter, the battery-chamber/memory card slot cover cannot be closed. Do not pull the cord of the AC adapter. If the cord is pulled, the connection between the camera and power source is interrupted, and the camera turns off.
Underwater speedlight	SB-N10 Underwater Speedlight To attach it to the COOLPIX W300, you need an SR-CP10A underwater fiber-optic cable adapter (available separately), an SC-N10A underwater fiber-optic cable (available separately), and an SK-N10A underwater bracket (available separately). See "Attaching the Underwater Speedlight" (📖209) for attachment instructions.

Availability may vary with country or region.
See our website or brochures for the latest information.



Attaching the Underwater Speedlight

You can use an SB-N10 underwater speedlight attached to the COOLPIX W300 to shoot underwater with flash. Set **Underwater flash** (📖170) in the setup menu to **On** when shooting.

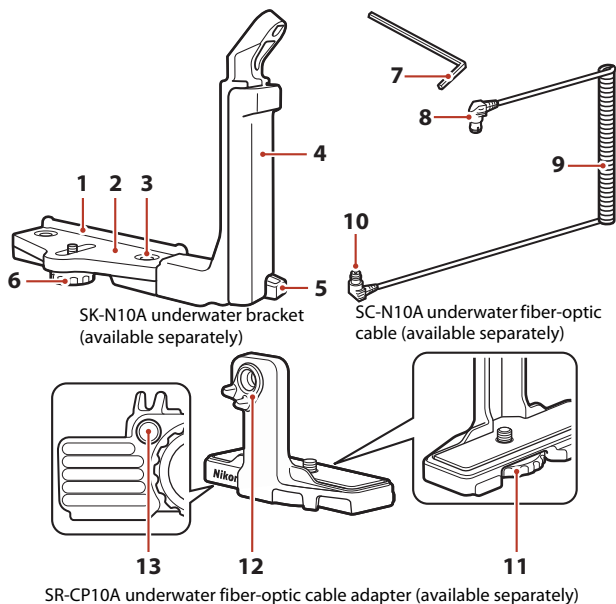

1 Mounting guide

2 Stay

3 Grip lock screw

4 Grip

5 Strap hook

6 Case/adapter lock screw

7 M4 hex key

8 Connector (connects to SB-N10)

9 Cable

10 Connector (connects to SR-CP10A)

11 Camera lock screw

12 Fiber-optic connector

13 Adapter lock screw socket



Make sure to turn off the camera and underwater speedlight before attaching.

1 Attach the camera to the underwater fiber-optic cable adapter.

- Align the camera lock screw of the cable adapter with the tripod socket of the camera, and securely tighten the screw.

✓ Notes

Make sure to properly thread the camera lock screw of the adapter in the tripod socket of the camera, and do not apply excessive force when tightening. Otherwise, you may damage the tripod socket.

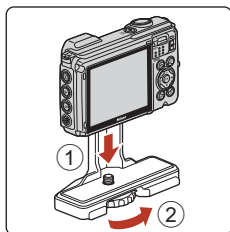

2 Attach the underwater speedlight to the grip of the underwater bracket.

- Securely tighten the mounting bolt of the underwater speedlight.

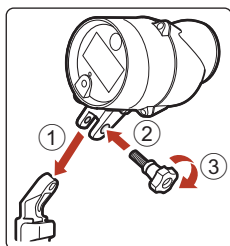

3 With the camera secured, attach the cable adapter to the underwater bracket.

- Align the case/adapter lock screw of the bracket with the cable adapter lock screw socket, and tighten the screw lightly so that the adapter and bracket can move.

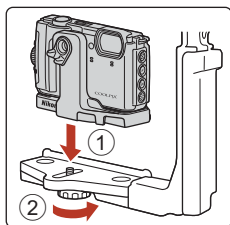

4 Attach the underwater fiber-optic cable to the cable adapter.

- Connect the end of the cable with the longer straight section (the end that connects to SR-CP10A) to the cable adapter's fiber-optic connector.
- After connecting, pass the cable through the adapter's two cable holders.

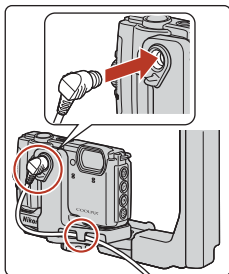

5 Slide the cable adapter that is attached to the camera and cable until it contacts the stay mounting guide.

- Make sure that the cable does not come loose from the cable holders.

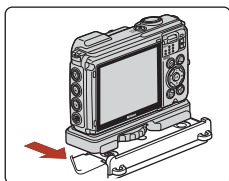

6 Fully tighten the case/adapter lock screw of the bracket to secure the cable adapter.

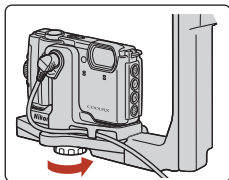

7 Pass the underwater fiber-optic cable through the grip of the bracket, from bottom to top.

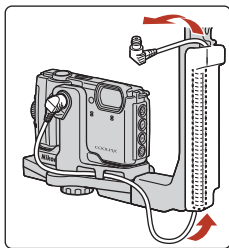

- 8** Open the sensor cover of the underwater speedlight.

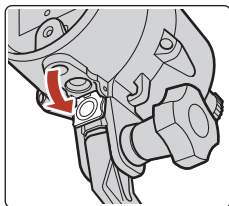

- 9** Connect one end of the cable (the end that connects to SB-N10) to the underwater speedlight's fiber-optic connector.

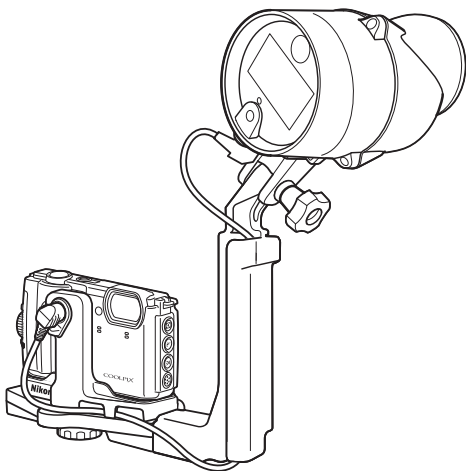
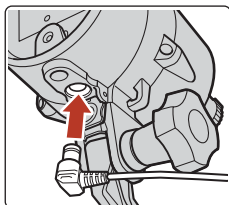

- To detach the underwater speedlight or camera from the underwater bracket, perform the above procedure in reverse.



Specifications

Nikon COOLPIX W300 Digital Camera

Type	Compact digital camera
Number of effective pixels	16.0 million (Image processing may reduce the number of effective pixels.)
Image sensor	6.2 × 4.7 mm (1/2.3-in. type) CMOS; approx. 16.79 million total pixels
Lens	NIKKOR lens with 5× optical zoom
Focal length	4.3–21.5 mm (angle of view equivalent to that of 24–120 mm lens in 35mm [135] format)
f/-number	f/2.8–4.9
Construction	12 elements in 10 groups (2 ED lens elements)
Digital zoom magnification	Up to 4× (angle of view equivalent to that of approx. 480 mm lens in 35mm [135] format)
Vibration reduction	Lens shift and electronic VR
Autofocus (AF)	Contrast-detect AF
Focus range	<ul style="list-style-type: none">• [W]: Approx. 50 cm (1 ft 8 in.)–∞,• [T]: Approx. 50 cm (1 ft 8 in.)–∞• Macro mode: Approx. 1 cm (0.4 in.)–∞ (wide-angle position) (All distances measured from center of front surface of lens)
Focus-area selection	Face priority, manual with 99 focus areas, center, subject tracking, target finding AF
Monitor	7.5 cm (3-in.), approx. 921k-dot, wide viewing angle TFT LCD with anti-reflection coating and 5-level brightness adjustment
Frame coverage (shooting mode)	Approx. 97% horizontal and vertical (compared to actual picture)
Frame coverage (playback mode)	Approx. 100% horizontal and vertical (compared to actual picture)
Storage	
Media	Internal memory (approx. 99 MB), SD/SDHC/SDXC memory card
File system	DCF and Exif 2.31 compliant
File formats	Still images: JPEG Movies: MP4 (Video: H.264/MPEG-4 AVC, Audio: AAC stereo)



Image size	
Still images	16 M (High) 4608×3456★ , 16 M 4608×3456 , 8 M 3264×2448 , 4 M 2272×1704 , 2 M 1600×1200 , VGA 640×480 , 16:9 12 M 4608×2592 , 1:1 3456×3456
Movies ¹	2160/30p (4K UHD), 2160/25p (4K UHD), 1080/30p, 1080/25p, 1080/60p, 1080/50p, 720/30p, 720/25p, 480/30p, 480/25p, HS 480/4x, HS 1080/0.5x
ISO sensitivity (Standard output sensitivity)	
<ul style="list-style-type: none"> • ISO 125–1600 • ISO 3200, 6400 (available when using Auto mode) 	
Exposure	
Metering mode	Matrix, center-weighted (digital zoom less than 2×), spot (digital zoom 2× or more)
Exposure control	Programmed auto exposure and exposure compensation (–2.0 – +2.0 EV in steps of 1/3 EV)
Shutter	
Speed	<ul style="list-style-type: none"> • 1/1500–1 s • 1/4000 s (maximum speed during high-speed continuous shooting) • 25 s (Star trails in Multiple exp. Lighten scene mode)
Aperture	
Range	Electronically-controlled preset aperture (–1 AV) and ND filter (–2 AV) selections 3 steps (f/2.8, f/4.1, f/8.2 [W])
Self-timer	
<ul style="list-style-type: none"> • 10 s, 2 s • 5 s (self-portrait timer) 	
Flash	
Range (approx.) (ISO sensitivity: Auto)	[W]: 0.5–5.2 m (1 ft 8 in.–17 ft) [T]: 0.5–4.5 m (1 ft 8 in.–14 ft)
Flash control	TTL auto flash with monitor preflashes
Interface	
USB connector	Micro-USB connector (Do not use any USB cable other than the included UC-E21 USB Cable.), Hi-Speed USB <ul style="list-style-type: none"> • Supports Direct Print (PictBridge)
HDMI output connector	HDMI micro connector (Type D)
Wi-Fi (Wireless LAN)	
Standards	IEEE 802.11b/g (standard wireless LAN protocol)
Operating frequency	2412–2462 MHz (1-11 channels)
Maximum output power	11.3 dBm (EIRP)
Authentication	Open system, WPA2-PSK



Bluetooth	
Communication protocols	Bluetooth Specification Version 4.1
Operating frequency	Bluetooth: 2402–2480 MHz Bluetooth Low Energy: 2402–2480 MHz
Electronic compass	
16 cardinal points (position correction using 3-axis acceleration sensor, automatic correction for the deviated angle, and automatic offset adjustment)	
Location data	
<ul style="list-style-type: none"> • GPS Receiving frequency: 1575.42 MHz Geodetic system: WGS 84 • GLONASS Receiving frequency: 1598.0625 - 1605.3750 MHz Geodetic system: WGS 84 	
Barometer	Display range: Approx. 500 - 4600 hPa
Altimeter	Display range: Approx. -300 - +4500 m (-984 - +14,760 ft)
Depth gauge	Display range: Approx. 0 - 35 m (0 - 114 ft)
Supported languages	
Arabic, Bulgarian, Chinese (Simplified and Traditional), Czech, Danish, Dutch, English, Finnish, French, German, Greek, Hindi, Hungarian, Indonesian, Italian, Japanese, Korean, Norwegian, Persian, Polish, Portuguese (European and Brazilian), Romanian, Russian, Serbian, Spanish, Swedish, Thai, Turkish, Ukrainian	
Power sources	One EN-EL12 Rechargeable Li-ion Battery (included) EH-62F AC Adapter (available separately)
Charging time	Approx. 2 h 20 min (when using EH-73P/EH-73PCH Charging AC Adapter and when no charge remains)
Battery life²	
Still images	Approx. 280 shots when using EN-EL12
Movie recording (actual battery life for recording) ³	Approx. 1 h (1080/30p) when using EN-EL12 Approx. 1 h (1080/25p) when using EN-EL12
LED light	Built-in
Tripod socket	0.635 cm (1/4 in., ISO 1222)
Dimensions (W × H × D)	Approx. 111.5 × 66.0 × 29.0 mm (4.4 × 2.6 × 1.2 in.) (excluding projections)
Weight	Approx. 231 g (8.2 oz) (including battery and memory card)
Operating environment	
Temperature	-10°C - +40°C (14°F - 104°F) (for land use) 0°C - 40°C (32°F - 104°F) (for underwater use)
Humidity	85% or less (no condensation)



Waterproof	JIS/IEC protection class 8 (IPX8) equivalent (under our testing conditions) Capacity to shoot images underwater up to a depth of 30 m (100 ft) and for 60 minutes
Dustproof	JIS/IEC protection class 6 (IP6X) equivalent (under our testing conditions)
Shockproof	Cleared our testing conditions ⁴ compliant with MIL-STD 810F Method 516.5-Shock

- All measurements are performed in conformity with Camera and Imaging Products Association (CIPA) standards or guidelines.

¹ When the battery temperature is below 0°C (32°F), movies with the size/frame rate set to 2160/30p (4K UHD), 2160/25p (4K UHD), 1080/60p, 1080/50p, HS 480/4x, or HS 1080/0.5x cannot be recorded.

² Battery life does not reflect the use of SnapBridge and the LED light and may vary with the conditions of use, including temperature, the interval between shots, and the length of time that menus and images are displayed.

³ Individual movie files cannot exceed 4 GB in size or 29 minutes in length. When **Movie options** is set to 1080/30p, it cannot exceed 27 minutes in length. Recording may end before this limit is reached if camera temperature becomes elevated.

⁴ Dropped from a height of 240 cm (7 ft 10 in.) onto a surface of 5 cm (2 in.) thick plywood (changes in appearance, such as paint peeling off and deformation of the drop shock portion and waterproof performance are not subject to the test).

These tests do not guarantee that the camera will be free from damage or trouble under all conditions.



EN-EL12 Rechargeable Li-ion Battery

Type	Rechargeable lithium-ion battery
Rated capacity	DC 3.7 V, 1050 mAh
Operating temperature	0°C–40°C (32°F–104°F)
Dimensions (W × H × D)	Approx. 32 × 43.8 × 7.9 mm (1.3 × 1.7 × 0.3 in.)
Weight	Approx. 22.5 g (0.8 oz)

EH-73P/EH-73PCH Charging AC Adapter

Rated input	AC 100–240 V, 50/60 Hz, MAX 0.14 A
Rated output	DC 5.0 V, 1.0 A, 5.0 W
Operating temperature	0°C–40°C (32°F–104°F)
Average active efficiency	73.77%
No-load power consumption	0.075 W
Dimensions (W × H × D)	Approx. 55 × 22 × 54 mm (2.2 × 0.9 × 2.2 in.) (excluding plug adapter) For Argentina: Approx. 55 × 63 × 59 mm (2.2 × 2.5 × 2.4 in.) For Brazil: Approx. 55 × 67 × 59 mm For India: Approx. 55 × 63.5 × 59 mm
Weight	Approx. 51 g (1.8 oz) (excluding plug adapter) For Argentina: Approx. 76 g (2.7 oz) For India: Approx. 81 g For Brazil: Approx. 73 g

The symbols on this product represent the following:

~ AC, == DC,  Class II equipment (The construction of the product is double-insulated.)

- Nikon will not be held liable for any errors this manual may contain.
- The appearance of this product and its specifications are subject to change without notice.



Notices for Customers in Europe

Distributor (Importer for EU Countries)

Nikon Europe B.V.

Tripolis 100, Burgerweeshuispad 101,
1076 ER Amsterdam, The Netherlands
+31-20-7099-000

Commercial registration number: 34036589



Memory Cards That Can Be Used

The camera supports SD, SDHC, and SDXC memory cards.

- The camera also supports SDHC and SDXC cards compliant with UHS-I.
- Memory cards with an SD Speed Class rating of 6 or faster are recommended for recording movies (when recording 4K UHD movies at an image size/frame rate of $\frac{2160}{60}$ **2160/30p** or $\frac{2160}{25}$ **2160/25p**, cards rated UHS Speed Class 3 or faster are recommended). When using a memory card with a lower Speed Class rating, movie recording may stop unexpectedly.
- If you use a card reader, make sure that it is compatible with your memory card.
- Contact the manufacturer for information on features, operation, and limitations on use.

Trademark Information

- Windows is either a registered trademark or trademark of Microsoft Corporation in the United States and/or other countries.
- The *Bluetooth*[®] word mark and logos are registered trademarks owned by Bluetooth SIG, Inc. and any use of such marks by Nikon Corporation is under license.
- Apple[®], App Store[®], the Apple logos, Mac, OS X, macOS, iPhone[®], iPad[®], iPod touch[®] and iBooks are trademarks or registered trademarks of Apple Inc., in the U.S. and other countries.
- Android, Google Play and the Google Play logo are trademarks of Google LLC. The Android robot is reproduced or modified from work created and shared by Google and used according to terms described in the Creative Commons 3.0 Attribution License.
- iOS is a trademark or registered trademark of Cisco Systems, Inc., in the United States and/or other countries and is used under license.



- Adobe, the Adobe logo, Acrobat, and Reader are either trademarks or registered trademarks of Adobe Systems Incorporated in the United States and/or other countries.
- SDXC, SDHC, and SD Logos are trademarks of SD-3C, LLC.



- PictBridge is a trademark.
- HDMI, HDMI logo and High-Definition Multimedia Interface are trademarks or registered trademarks of HDMI Licensing, LLC.

HDMI

- Wi-Fi and the Wi-Fi logo are trademarks or registered trademarks of the Wi-Fi Alliance.
- All other trade names mentioned in this manual or the other documentation provided with your Nikon product are the trademarks or registered trademarks of their respective holders.

“Made for iPod,” “Made for iPhone,” and “Made for iPad” mean that an electronic accessory has been designed to connect specifically to iPod, iPhone, or iPad, respectively, and has been certified by the developer to meet Apple performance standards. Apple is not responsible for the operation of this device or its compliance with safety and regulatory standards. Please note that the use of this accessory with iPod, iPhone, or iPad may affect wireless performance.

AVC Patent Portfolio License

This product is licensed under the AVC Patent Portfolio License for the personal and non-commercial use of a consumer to (i) encode video in compliance with the AVC standard (“AVC video”) and/or (ii) decode AVC video that was encoded by a consumer engaged in a personal and non-commercial activity and/or was obtained from a video provider licensed to provide AVC video. No license is granted or shall be implied for any other use.

Additional information may be obtained from MPEG LA, L.L.C.

See <http://www.mpegla.com>.

FreeType License (FreeType2)

- Portions of this software are copyright © 2012 The FreeType Project (<http://www.freetype.org>). All rights reserved.

MIT License (HarfBuzz)

- Portions of this software are copyright © 2017 The HarfBuzz Project (<http://www.freedesktop.org/wiki/Software/HarfBuzz>). All rights reserved.



USER LICENSE AGREEMENT FOR LOCATION NAME DATA

The location name data that is stored in this digital camera ("Data") is provided for your personal, internal use only and not for resale. It is protected by copyright, and is subject to the following terms and conditions which are agreed to by you, on the one hand, and Nikon Corporation ("Nikon") and its licensors (including their licensors and suppliers) on the other hand.

Terms and Conditions

Personal Use Only. You agree to use this Data together with this digital camera and the image data taken by the digital camera for the solely personal, non-commercial purposes for which you were licensed, and not for service bureau, time-sharing or other similar purposes. Accordingly, but subject to the restrictions set forth in the following paragraphs, you agree not to otherwise reproduce, copy, modify, decompile, disassemble or reverse engineer any portion of this Data, and may not transfer or distribute it in any form, for any purpose, except to the extent permitted by mandatory laws.

Restrictions. Except where you have been specifically licensed to do so by Nikon, and without limiting the preceding paragraph, you may not (a) use this Data with any products, systems, or applications installed or otherwise connected to or in communication with vehicles, capable of vehicle navigation, positioning, dispatch, real time route guidance, fleet management or similar applications; or (b) with or in communication with any positioning devices or any mobile or wireless-connected electronic or computer devices, including without limitation cellular phones, palmtop and handheld computers, pagers, and personal digital assistants or PDAs.

Warning. The Data may contain inaccurate or incomplete information due to the passage of time, changing circumstances, sources used and the nature of collecting comprehensive geographic data, any of which may lead to incorrect results.

No Warranty. This Data is provided to you "as is," and you agree to use it at your own risk. Nikon and its licensors (and their licensors and suppliers) make no guarantees, representations or warranties of any kind, express or implied, arising by law or otherwise, including but not limited to, content, quality, accuracy, completeness, effectiveness, reliability, fitness for a particular purpose, usefulness, use or results to be obtained from this Data, or that the Data or server will be uninterrupted or error-free.

Disclaimer of Warranty: NIKON AND ITS LICENSORS (INCLUDING THEIR LICENSORS AND SUPPLIERS) DISCLAIM ANY WARRANTIES, EXPRESS OR IMPLIED, OF QUALITY, PERFORMANCE, MERCHANTABILITY, FITNESS FOR A PARTICULAR PURPOSE OR NON-INFRINGEMENT. Some States, Territories and Countries do not allow certain warranty exclusions, so to that extent the above exclusion may not apply to you.



Disclaimer of Liability: NIKON AND ITS LICENSORS (INCLUDING THEIR LICENSORS AND SUPPLIERS) SHALL NOT BE LIABLE TO YOU: IN RESPECT OF ANY CLAIM, DEMAND OR ACTION, IRRESPECTIVE OF THE NATURE OF THE CAUSE OF THE CLAIM, DEMAND OR ACTION ALLEGING ANY LOSS, INJURY OR DAMAGES, DIRECT OR INDIRECT, WHICH MAY RESULT FROM THE USE OR POSSESSION OF THE INFORMATION; OR FOR ANY LOSS OF PROFIT, REVENUE, CONTRACTS OR SAVINGS, OR ANY OTHER DIRECT, INDIRECT, INCIDENTAL, SPECIAL OR CONSEQUENTIAL DAMAGES ARISING OUT OF YOUR USE OF OR INABILITY TO USE THIS INFORMATION, ANY DEFECT IN THE INFORMATION, OR THE BREACH OF THESE TERMS OR CONDITIONS, WHETHER IN AN ACTION IN CONTRACT OR TORT OR BASED ON A WARRANTY, EVEN IF NIKON OR ITS LICENSORS HAVE BEEN ADVISED OF THE POSSIBILITY OF SUCH DAMAGES. Some States, Territories and Countries do not allow certain liability exclusions or damages limitations, so to that extent the above may not apply to you.

Export Control. You agree not to export from anywhere any part of the Data or any direct product thereof except in compliance with, and with all licenses and approvals required under, applicable export laws, rules and regulations, including but not limited to the laws, rules and regulations administered by the Office of Foreign Assets Control of the U.S. Department of Commerce and the Bureau of Industry and Security of the U.S. Department of Commerce. To the extent that any such export laws, rules or regulations prohibit Nikon and its licensors from complying with any of its obligations hereunder to deliver or distribute Data, such failure shall be excused and shall not constitute a breach of this Agreement.

Entire Agreement. These terms and conditions constitute the entire agreement between Nikon (and its licensors, including their licensors and suppliers) and you pertaining to the subject matter hereof, and supersedes in their entirety any and all written or oral agreements previously existing between us with respect to such subject matter.

Governing Law. The above terms and conditions shall be governed by the laws of the Japan, without giving effect to (i) its conflict of laws provisions, or (ii) the United Nations Convention for Contracts for the International Sale of Goods, which is explicitly excluded; provided that in the event that the laws of the Japan is not deemed applicable to this Agreement for any reason in the country where you obtained the Data, this Agreement shall be governed with the laws of the country where you obtained the Data. You agree to submit to the jurisdiction of Japan for any and all disputes, claims and actions arising from or in connection with the Data provided to you hereunder.



Government End Users. If the Data supplied by HERE is being acquired by or on behalf of the United States government or any other entity seeking or applying rights similar to those customarily claimed by the United States government, the Data is a "commercial item" as that term is defined at 48 C.F.R. ("FAR") 2.101, is licensed in accordance with the End-User Terms under which this Data was provided, and each copy of the Data delivered or otherwise furnished shall be marked and embedded as appropriate with the following "Notice of Use," and shall be treated in accordance with such Notice:

NOTICE OF USE
CONTRACTOR (MANUFACTURER/ SUPPLIER) NAME:
HERE
CONTRACTOR (MANUFACTURER/ SUPPLIER) ADDRESS:
425 West Randolph Street, Chicago, Illinois 60606
This Data is a commercial item as defined in
FAR 2.101 and is subject to the End-User
Terms under which this Data was provided.
© 2017 HERE All Rights Reserved

If the Contracting Officer, federal government agency, or any federal official refuses to use the legend provided herein, the Contracting Officer, federal government agency, or any federal official must notify HERE prior to seeking additional or alternative rights in the Data.

Notices related to licensed software copyright holders.

- Location name data for Japan



© ZENRIN CO., LTD. All rights reserved.
This service uses POI data of ZENRIN CO., LTD.
"ZENRIN" is a registered trademark of ZENRIN CO., LTD.

- Location name data except for Japan



© 2017 HERE All Rights Reserved



Austria: © Bundesamt für Eich- und Vermessungswesen

Belgium: © - Distribution & Copyright CIRB

Croatia/Cyprus/Estonia/Latvia/Lithuania/Moldova/Poland/Slovenia/Ukraine: © EuroGeographics

Denmark: Contains data that is made available by the Danish Geodata Agency (FOT) Retrieved by HERE 01/2014

Finland: Contains data from the National Land Survey of Finland Topographic Database 06/2012. (Terms of Use available at http://www.maanmittauslaitos.fi/en/NLS_open_data_licence_version1_20120501).

Contains data that is made available by Itella in accordance with the terms available at http://www.itella.fi/liitteet/palvelutjatuotteet/yhteystietopalvelut/uusj_postal_code_services_service_description_and_terms_of_use.pdf. Retrieved by HERE 09/2013

France: source: © IGN 2009 – BD TOPO ©

Germany: Die Grundlagendaten wurden mit Genehmigung der zuständigen Behörden entnommen. Contains content of „BayrischeVermessungsverwaltung – www.geodaten.bayern.de“, licensed in accordance with <http://creativecommons.org/licenses/by/3.0/legalcode>

Contains content of “LGL, www.lgl-bw.de“, licensed in accordance with <http://creativecommons.org/licenses/by/3.0/legalcode>

Contains content of “Stadt Köln – offenedaten-koeln.de“, licensed in accordance with <http://creativecommons.org/licenses/by/3.0/legalcode>

Contains Content of “Geoportal Berlin / ATKIS® Basis-DLM“, licensed in accordance with <http://www.stadtentwicklung.berlin.de/geoinformation/download/nutzlll.pdf>

Contains Content of “Geoportal Berlin / Karte von Berlin 1:5000 (K5-Farbausgabe)“, licensed in accordance with <http://www.stadtentwicklung.berlin.de/geoinformation/download/nutzlll.pdf>

Great Britain: Contains Ordnance Survey data © Crown copyright and database right 2010

Contains Royal Mail data © Royal Mail copyright and database right 2010

Greece: Copyright Geomatics Ltd.

Italy: La Banca Dati Italiana è stata prodotta usando quale riferimento anche cartografia numerica ed al tratto prodotta e fornita dalla Regione Toscana.

Contains data from Trasporto Passeggeri Emilia-Romagna- S.p.A.

Includes content of Comune di Bologna licensed under <http://creativecommons.org/licenses/by/3.0/legalcode> and updated by licensee July 1, 2013.

Includes content of Comune di Cesena licensed under <http://creativecommons.org/licenses/by/3.0/legalcode> and updated by licensee July 1, 2013.

Includes contents of Ministero della Salute, and Regione Sicilia, licensed under <http://www.formez.it/iodl/> and updated by licensee September 1, 2013.

Includes contents of Provincia di Enna, Comune di Torino, Comune di Pisa, Comune di Trapani, Comune di Vicenza, Regione Lombardia, Regione Umbria, licensed under <http://www.dati.gov.it/iodl/2.0/> and updated by licensee September 1, 2013.

Includes content of GeoforUs, licensed in accordance with <http://creativecommons.org/licenses/by/3.0/legalcode>.

Includes content of Comune di Milano, licensed under <http://creativecommons.org/licenses/by/2.5/it/legalcode> and updated by licensee November 1, 2013.

Includes content of the “Comunità Montana della Carnia“, licensed under <http://www.dati.gov.it/iodl/2.0/> and updated by licensee December 1, 2013.

Includes content of “Agenzia per la mobilità“ licensed under <http://creativecommons.org/licenses/by/3.0/legalcode> and updated by licensee January 1, 2014.

Includes content of Regione Sardegna, licensed under <http://www.dati.gov.it/iodl/2.0/> and updated by licensee May 1, 2014.

Includes content of CISIS, licensed under <http://creativecommons.org/licenses/by/2.5/legalcode>.

Norway: Copyright © 2000; Norwegian Mapping Authority

Includes data under the Norwegian licence for Open Government data (NLOD), available at <http://data.norge.no/nlod/en/1.0>

Contains information copyrighted by © Kartverket, made available in accordance with <http://creativecommons.org/licenses/by/3.0/no/>.



Contains data under the Norwegian licence for Open Government data (NLOD) distributed by Norwegian Public Roads Administration (NPRA)

Portugal: Source: IgeoE – Portugal

Spain: Información geográfica propiedad del CNIG

Contains data that is made available by the Generalitat de Catalunya Government in accordance with the terms available at http://www.gencat.cat/web/eng/avis_legal.htm. Retrieved by HERE 05/2013.

Contains content of Centro Municipal de Informatica – Malaga, licensed in accordance with <http://creativecommons.org/licenses/by/3.0/legalcode>.

Contains content of Administración General de la Comunidad Autónoma de Euskadi, licensed in accordance with <http://creativecommons.org/licenses/by/3.0/legalcode>

Contains data made available by the Ayuntamiento de Santander, licensed in accordance with <http://creativecommons.org/licenses/by/3.0/es/legalcode.es>

Contains data of Ajuntament de Sabadell, licensed per <http://creativecommons.org/licenses/by/3.0/legalcode>, updated 4/2013

Sweden: Based upon electronic data © National Land Survey Sweden.

Contains public data, licensed under Go Open v1.0, available at <http://data.goteborg.se/goopen/Avtal%20GoOpen%201.0.0.pdf>

Switzerland: Topografische Grundlage: © Bundesamt für Landestopographie

United Kingdom: Contains public sector information licensed under the Open Government Licence v1.0 (see for the license <http://www.nationalarchives.gov.uk/doc/open-government-licence/>)

Adapted from data from the office for National Statistics licensed under the Open Government Licence v.1.0

Canada: This data includes information taken with permission from Canadian authorities, including © Her Majesty, © Queen's Printer for Ontario, © Canada Post, GeoBase®, © Department of Natural Resources Canada. All rights reserved.

Mexico: Fuente: INEGI (Instituto Nacional de Estadística y Geografía.)

United States: ©United States Postal Service® 2013. Prices are not established, controlled or approved by the United States Postal Service®. The following trademarks and registrations are owned by the USPS: United States Postal Service, USPS, and ZIP+4.

Includes data available from the U.S. Geological Survey.

Australia: Copyright. Based on data provided under license from PSMA Australia Limited (www.pasma.com.au).

Product incorporates data which is © 2013 Telstra Corporation Limited, Intelomatics Australia Pty Ltd and HERE International LLC.

Nepal: Copyright © Survey Department, Government of Nepal.

Sri Lanka: This product incorporates original source digital data obtained from the Survey Department of Sri Lanka

© 2009 Survey Department of Sri Lanka

The data has been used with the permission of the Survey Department of Sri Lanka

Israel: © Survey of Israel data source

Jordan: © Royal Jordanian Geographic Centre.

Mozambique: Certain Data for Mozambique provided by Cenacarta © 2013 by Cenacarta

Nicaragua: The Pacific Ocean and Caribbean Sea maritime borders have not been entirely defined.

Northern land border defined by the natural course of the Coco River (also known as Segovia River or Wangki River) corresponds to the source of information available at the moment of its representation.

Réunion: source: © IGN 2009 - BD TOPO ®

Ecuador: INSTITUTO GEOGRAFICO MILITAR DEL ECUADOR

AUTORIZACION N° IGM-2011-01- PCO-01 DEL 25 DE ENERO DE 2011

Guadeloupe: source: © IGN 2009 - BD TOPO ®

Guatemala: Aprobado por el INSTITUTO GEOGRAFICO NACIONAL – Resolución del IGN No 186-2011

French Guiana: source: © IGN 2009 - BD TOPO ®

Martinique: source: © IGN 2009 - BD TOPO ®





Index

Symbols

 Scene auto selector mode
..... 18, 26, 28

 Scene mode..... 26, 30

 Creative mode..... 26, 40

 Smart portrait mode 26, 42

 Short movie show mode 26, 88

 Auto mode 26, 47

 Playback mode..... 21

 List by date mode..... 69

 Playback zoom 21, 67

W (Wide-angle)..... 3, 56

 Thumbnail playback..... 21, 68

T (Telephoto)..... 3, 56

 LED light button 2, 3, 20

 Action button..... 3, 24

 Apply selection button 3, 120

 Playback button..... 3, 21

 Delete button..... 3, 22

 Shooting mode button 3, 26

 Tool button..... 3, 105

 (Movie-record) button..... 3, 20

MENU Menu button..... 3, 120

 Self-timer 49, 52

 Flash mode 49, 50

 Macro mode..... 49, 54

 Exposure compensation
..... 42, 47, 49, 55

A

AC adapter..... 109, 208

Action control 24

Action control response 127, 171

Active D-Lighting..... 47

Active guide 8, 105

AF area mode 123, 124, 135, 145

AF assist..... 127, 169

AF-assist illuminator..... 2

A-GPS file 99

Airplane mode 125, 154

Altimeter 100

Altitude 100

Altitude log..... 101, 104

Altitude/depth options 126, 162

App..... 15

Atmospheric pressure 100

Auto flash 51

Auto mode 26, 47

Auto off..... 20, 127, 172

Auto with red-eye reduction 51

Autofocus..... 60, 138, 146

Autofocus mode... 123, 124, 138, 146

B

Background music..... 88

Backlighting ..... 30, 33

Battery 11, 215

Battery charger..... 208

Battery level..... 19

Battery-chamber/memory card slot
cover..... 2, 11, 13, 109

Beach ..... 30

Blink proof..... 123, 140

Bluetooth..... 125, 155

Brightness..... 165

Button sound 170

C

Calendar display..... 68





Capturing still images while recording
movies..... 84

Charge by computer 127, 176







Charge lamp..... 3, 13

Charging AC adapter 13, 217









Close-up 	30, 32	File names	206
Compression ratio	128	Fill flash	51
Computer	108, 115	Fireworks show 	30, 33
Conformity marking	127, 177	Firmware version	127, 177
Connect to smart device	125, 154	Fixed range auto	134
Continuous shooting	123, 132	Flash	2, 50
Copy	125, 152	Flash lamp	3, 50
Copyright information	127, 175	Flash mode	49, 50
Create log	95, 101, 126, 159	Flash off	51
Creative mode	26, 40	F-number	57
Creative slider	47	Focus	19, 57, 135, 138, 145, 146
Crop	67, 78	Focus area	6, 19
D		Focus indicator	4
Data imprint	76, 125	Focus lock	61
Date and time	15, 163	Food 	30, 32
Date format	16, 163	Format internal memory	127, 173
Date stamp	127, 167	Format memory cards	12, 127, 173
Daylight saving time	16, 164	Formatting	12, 173
Delete	22, 71	Foundation makeup	43
Depth gauge	100	Frame rate	124, 148
Digital zoom	56, 127, 169	Full-frame playback	21
Direct print	108, 111	Full-time AF	138, 146
D-Lighting	74, 125	Functions that cannot be used simultaneously	64
Dusk/dawn 	30	G	
E		Glamour retouch	42, 75, 125
Easy panorama 	30, 37	H	
Easy panorama playback	39	HDMI cable	108, 110
Editing images	72	HDMI micro connector	2, 109
Electronic compass	126, 161	HDR	33
End recording	89	Help display	165
Exposure compensation	42, 47, 49, 55	High-speed continuous	132
Extracting still images	91, 93	Histogram	55
Eyelet for camera strap	2	HS movie	142, 144
E		Hue	47
Face detection	58	I	
Face priority	135, 145	Image comment	127, 174



- Image mode..... 123, 128 **N**
- Image review 165 Network menu 120, 154
- Internal memory 11 Night landscape  30, 32
- Internal memory indicator 6 Night portrait  30, 31
- Interval 139 Number of exposures remaining
..... 19, 129
- ISO sensitivity..... 123, 134 Number of shots 88, 139
- L** NX Studio..... 115
- Landscape  30
- Language 127, 173 **O**
- LED light..... 2, 20 Optical zoom..... 18, 56
- LED light timer 127, 172 Optional accessories..... 208
- Lens..... 2, 213 **P**
- List by date mode 69 Paper size..... 112, 113
- Location data 97 Party/indoor  30, 31
- Location data options 95, 126, 157 Pet portrait auto release..... 34
- Location data options menu
..... 120, 157 Pet portrait  30, 34
- M** Photo info..... 165
- Macro mode..... 49, 54 Photo VR..... 127, 168
- Mark for upload 125, 149 PictBridge 108, 111
- Memory card..... 11, 188, 218 Playback 21, 70, 91
- Memory card slot 11 Playback action control ... 24, 127, 171
- Microphone (stereo)..... 2 Playback menu..... 120, 149
- Micro-USB connector
..... 2, 13, 109, 111, 115 Playback mode..... 21
- Monitor 3, 4 Playback zoom 21, 67
- Monitor settings..... 127, 165 POI information 96
- Movie editing..... 92, 93 Points of interest (POI)..... 96, 126, 158
- Movie light 124, 147 Portrait  30
- Movie menu 120, 141 Power switch/power-on lamp 2, 15
- Movie options 124, 141 Preset manual..... 131
- Movie playback..... 21, 80 Pre-shooting cache 132, 133
- Movie recording..... 20, 80 Pressing halfway 19, 57
- Movie VR..... 124, 147 Print..... 108, 112, 113
- Multi selector 3, 120 Printer 108, 111
- Multiple exp. Lighten  30, 35 Protect..... 125, 151
- N** **Q**
- Quick effects..... 72
- Quick retouch 73, 125



R	
Rechargeable Li-ion battery	217
Recording slow motion movies	142, 144
Red-eye correction	74, 125
Remaining movie recording time	80, 81
Reset all	127, 177
Restore default settings	125, 155
Rotate image	125, 151
S	
Scene auto selector mode	26, 28
Scene mode	26, 30
SD memory card	11, 188, 218
Self-collage	45, 123, 139
Self-portrait timer	52
Self-timer	49, 52
Self-timer lamp	2, 52
Send while shooting	125, 154
Sequence display	70, 125, 153
Set clock from satellite	126, 160
Setup menu	120, 163
Shooting	18, 26
Shooting menu	120, 130
Shooting mode	26
Short movie show menu	88
Short movie show mode	26, 88
Shutter sound	139, 170
Shutter speed	57
Shutter-release button	2, 19
Single AF	138, 146
Single-frame shooting	132
Skin softening	43
Slide show	125, 150
Slow sync	51
Small picture	77, 125
Smart portrait menu	120, 139
Smart portrait mode	26, 42
Smile timer	44
SnapBridge app	15
Snow 	30
Soft	42
Sound settings	127, 170
Speaker	3
Special effects	88, 90
Sports 	30, 31
Strap	10
Strap for land use	10
Subject tracking	136, 137
Sunset 	30
Superlapse movie 	30, 87
Sync with smart device	163
T	
Target finding AF	59, 136
Telephoto	18, 56
Thumbnail playback	21, 68
Time difference	164
Time zone	16, 163
Time zone and date	15, 127, 163
Time-lapse movie 	30, 85
Tripod socket	3, 215
TV	108, 110
U	
Underwater 	30, 36
Underwater flash	127, 170, 209
USB cable	13, 108, 111, 115
V	
View log	104, 126, 160
Vividness	42, 47
Volume	91
W	
Water depth	100
Water depth log	101, 104
White balance	123, 130
Wide-angle	18, 56



Wi-Fi.....	125, 154
Wind noise reduction	124, 148
Z	
Zoom	18, 56
Zoom control.....	3, 18, 56
Zooming in/out	56



No reproduction in any form of this manual, in whole or in part (except for brief quotation in critical articles or reviews), may be made without written authorization from NIKON CORPORATION.

NIKON CORPORATION

© 2017 Nikon Corporation



CT2D07(11)
6MQA6411-07