

**Nikon**

DIGITAL CAMERA

# COOLPIX L23

## User's Manual



En

### **Trademark Information**

- Microsoft, Windows and Windows Vista are either registered trademarks or trademarks of Microsoft Corporation in the United States and/or other countries.
- Macintosh, Mac OS, and QuickTime are trademarks of Apple Inc., registered in the U.S. and other countries.
- Adobe and Acrobat are registered trademarks of Adobe Systems Inc.
- SDXC, SDHC and SD Logos are trademarks of SD-3C, LLC.
- PictBridge is a trademark.
- All other trade names mentioned in this manual or the other documentation provided with your Nikon product are trademarks or registered trademarks of their respective holders.

**Introduction**

**First Steps**

**Basic Photography and Playback:  Easy Auto Mode**

**More on Shooting**

**More on Playback**

**Editing Image**

**Movie Recording and Playback**

**Connecting to Televisions, Computers and Printers**

**Basic Camera Setup**

**Notes on Camera Care and General Usage**

**Technical Notes**

## For Your Safety

To prevent damage to your Nikon product or injury to yourself or to others, read the following safety precautions in their entirety before using this equipment. Keep these safety instructions where all those who use the product will read them. The consequences that could result from failure to observe the precautions listed in this section are indicated by the following symbol:



This icon marks warnings, information that should be read before using this Nikon product, to prevent possible injury.

### WARNINGS

#### **Turn off in the event of malfunction**

Should you notice smoke or an unusual smell coming from the camera or AC adapter, unplug the AC adapter and remove the batteries immediately, taking care to avoid burns. Continued operation could result in injury. After removing or disconnecting the power source, take the equipment to a Nikon-authorized service representative for inspection.

#### **Do not disassemble**

Touching the internal parts of the camera or AC adapter could result in injury. Repairs should be performed only by qualified technicians. Should the camera or AC adapter break open as the result of a fall or other accident, take the product to a Nikon-authorized service representative for inspection, after unplugging the product and/or removing the batteries.

#### **Do not use the camera or AC adapter in the presence of flammable gas**

Do not use electronic equipment in the presence of flammable gas, as this could result in explosion or fire.

#### **Handle the camera strap with care**

Never place the strap around the neck of an infant or child.

#### **Keep out of reach of children**

Particular care should be taken to prevent infants from putting the batteries or other small parts into their mouths.

### **Observe caution when handling batteries**

Batteries may leak or explode if improperly handled. Observe the following precautions when handling batteries for use in this product:

- Before replacing the batteries, turn the product off. If you are using an AC adapter, be sure it is unplugged.
- Use only the batteries approved for use in this product (📖 12). Do not combine old and new batteries or batteries of different makes or types.
- If Nikon rechargeable Ni-MH batteries EN-MH2 (EN-MH2-B2 or EN-MH2-B4) are purchased separately, charge and use each of them as a set. Do not combine batteries from different pairs.
- The EN-MH2 rechargeable batteries are for use with Nikon digital cameras only, and are compatible with COOLPIX L23.  
Do not use EN-MH2 rechargeable batteries with incompatible devices.
- Insert batteries in the correct orientation.
- Do not short or disassemble batteries or attempt to remove or break battery insulation or casing.
- Do not expose batteries to flame or to excessive heat.
- Do not immerse in or expose to water.
- Do not transport or store with metal objects such as necklaces or hairpins.
- Batteries are prone to leakage when fully discharged. To avoid damage to the product, be sure to remove the batteries when no charge remains.

- Discontinue use immediately should you notice any change in the batteries, such as discoloration or deformation.
- If liquid from damaged batteries comes in contact with clothing or skin, rinse immediately with plenty of water.

### **Observe the following precautions when handling the Battery Chargers (available separately)**

- Keep Dry. Failure to observe this precaution could result in fire or electric shock.
- Dust on or near the metal parts of the plug should be removed with a dry cloth. Continued use could result in fire.
- Do not handle the power cable or go near the battery charger during lightning storms. Failure to observe this precaution could result in electric shock.
- Do not damage, modify, forcibly tug or bend the power cable, place it under heavy objects, or expose it to heat or flame. Should the insulation be damaged and the wires become exposed, take it to a Nikon-authorized service representative for inspection. Failure to observe these precautions could result in fire or electric shock.
- Do not handle the plug or battery charger with wet hands. Failure to observe this precaution could result in electric shock.

## For Your Safety

- Do not use with travel converters or adapters designed to convert from one voltage to another or with DC-to-AC inverters. Failure to observe this precaution could damage the product or result in overheating or fire.

### **Use appropriate cables**

When connecting cables to the input and output jacks, use only the cables provided or sold by Nikon for the purpose, to maintain compliance with product regulations.

### **Handle moving parts with care**

Be careful that your fingers or other objects are not pinched by the lens cover or other moving parts.

### **CD-ROMs**

The CD-ROMs supplied with this device should not be played back on audio CD equipment. Playing CD-ROMs on an audio CD player could cause hearing loss or damage the equipment.

### **Observe caution when using the flash**

Using the flash close to your subject's eyes could cause temporary visual impairment. Particular care should be observed if photographing infants, when the flash should be no less than 1 m (3 ft. 4 in.) from the subject.

### **Do not operate the flash with the flash window touching a person or object**

Failure to observe this precaution could result in burns or fire.

### **Avoid contact with liquid crystal**

Should the monitor break, care should be taken to avoid injury caused by broken glass and to prevent liquid crystal from the monitor touching the skin or entering the eyes or mouth.

### **Turn the power off when using inside an airplane or the hospital**

Turn the power off while inside the airplane during take off or landing. Follow the instructions of the hospital when using while in a hospital. The electromagnetic waves given out by this camera may disrupt the electronic systems of the airplane or the instruments of the hospital.

# Notices

## Notice for Customers in the U.S.A.

### **Federal Communications Commission (FCC) Radio Frequency Interference Statement**

This equipment has been tested and found to comply with the limits for a Class B digital device, pursuant to Part 15 of the FCC rules. These limits are designed to provide reasonable protection against harmful interference in a residential installation. This equipment generates, uses, and can radiate radio frequency energy and, if not installed and used in accordance with the instructions, may cause harmful interference to radio communications. However, there is no guarantee that interference will not occur in a particular installation. If this equipment does cause harmful interference to radio or television reception, which can be determined by turning the equipment off and on, the user is encouraged to try to correct the interference by one or more of the following measures:

- Reorient or relocate the receiving antenna.
- Increase the separation between the equipment and receiver.
- Connect the equipment into an outlet on a circuit different from that to which the receiver is connected.
- Consult the dealer or an experienced radio/television technician for help.



**Nikon**

COOLPIX L23

### **CAUTIONS**

#### **Modifications**

The FCC requires the user to be notified that any changes or modifications made to this device that are not expressly approved by Nikon Corporation may void the user's authority to operate the equipment.

#### **Interface Cables**

Use the interface cables sold or provided by Nikon for your equipment. Using other interface cables may exceed the limits of Class B Part 15 of the FCC rules.

#### **Notice for customers in the State of California**

#### **WARNING**

Handling the cord on this product will expose you to lead, a chemical known to the State of California to cause birth defects or other reproductive harm.

#### ***Wash hands after handling.***

Nikon Inc.,  
1300 Walt Whitman Road  
Melville, New York 11747-3064  
USA  
Tel: 631-547-4200

## **Notice for customers in Canada**

### **CAUTION**

This Class B digital apparatus complies with Canadian ICES-003.

### **ATTENTION**

Cet appareil numérique de la classe B est conforme à la norme NMB-003 du Canada.

### **Symbol for Separate Collection in European Countries**

This symbol indicates that this product is to be collected separately.



The following apply only to users in European countries:

- This product is designated for separate collection at an appropriate collection point. Do not dispose of as household waste.
- For more information, contact the retailer or the local authorities in charge of waste management.

This symbol on the battery indicates that the battery is to be collected separately.



The following apply only to users in European countries:

- All batteries, whether marked with this symbol or not, are designated for separate collection at an appropriate collection point. Do not dispose of as household waste.
- For more information, contact the retailer or the local authorities in charge of waste management.

# Table of Contents





For Your Safety .....	ii
WARNINGS .....	ii
Notices .....	v
<hr/>	
Introduction .....	1
About This Manual .....	1
Information and Precautions .....	2
Parts of the Camera .....	4
The Camera Body .....	4
Attaching the Camera Strap .....	4
The Monitor .....	6
Basic Operations .....	8
📷 (Shooting Mode) Button .....	8
▶ (Playback) Button .....	8
The Multi Selector .....	9
Using Camera Menus .....	10
Switching Between Tabs of Menu Screen .....	11
The Shutter-release Button .....	11
<hr/>	
First Steps .....	12
Inserting the Batteries .....	12
Applicable Batteries .....	12
Turning On and Off the Camera .....	12
Setting Display Language, Date and Time .....	14
Inserting Memory Cards .....	16
Removing Memory Cards .....	16
<hr/>	
Basic Photography and Playback: 📷 Easy Auto Mode .....	18
Step 1 Turn the Camera On and Select 📷 (Easy Auto) Mode .....	18
Indicators Displayed in 📷 (Easy Auto) Mode .....	19
Step 2 Frame a Picture .....	20
Using the Zoom .....	21
Step 3 Focus and Shoot .....	22
Step 4 Viewing and Deleting Images .....	24
Viewing Images (Playback Mode) .....	24
Deleting Unwanted Images .....	25
Using the Flash .....	26
Selecting a Flash Mode .....	26
Taking Pictures with the Self-timer .....	28
Adjusting the Brightness: Exposure Compensation .....	29

## Table of Contents





---

<b>More on Shooting</b> .....	<b>30</b>
Selecting Shooting Mode .....	30
Easy Auto Mode .....	31
<b>Shooting Suited for the Scene (Scene Mode)</b> .....	<b>32</b>
Selecting a Scene Mode .....	32
Choosing a Scene and Shooting (Scene Mode Types and Characteristics) .....	33
Taking Pictures for a Panorama .....	41
<b>Capturing Smiling Faces Automatically (Smart Portrait Mode)</b> .....	<b>43</b>
Changing the Smart Portrait Settings .....	45
<b>Auto Mode</b> .....	<b>46</b>
Macro Mode .....	47
Changing  (Auto) Mode Settings (Shooting Menu) .....	48
Image Mode (Image Quality/Image Size) .....	49
White Balance (Adjusting Hue) .....	51
Continuous .....	53
Color Options .....	54
Camera Settings that Cannot Be Set at the Same Time .....	55

---

<b>More on Playback</b> .....	<b>56</b>
Full-frame Operation .....	56
<b>Viewing Multiple Images: Thumbnail Playback</b> .....	<b>57</b>
Calendar Display .....	58
<b>Taking a Closer Look: Playback Zoom</b> .....	<b>59</b>
<b>Playback Menu</b> .....	<b>60</b>
 Print Order .....	61
 Slide Show .....	64
 Protect .....	65
 Rotate Image .....	67
 Copy: Copying Between Memory Card and Internal Memory .....	68

---

<b>Editing Image</b> .....	<b>69</b>
Image Editing Function .....	69
<b>Editing Images</b> .....	<b>70</b>
 D-Lighting: Enhancing Brightness and Contrast .....	70
 Skin Softening: Softening Skin Tones .....	71
 Small Picture: Decreasing Image Size .....	72
 Crop: Creating a Cropped Copy .....	73

---

<b>Movie Recording and Playback</b> .....	<b>75</b>
<b>Recording Movies</b> .....	<b>75</b>
Changing Movie Recording Settings .....	76
Movie Options.....	77
<b>Movie Playback</b> .....	<b>78</b>
Deleting Movies.....	78

---

<b>Connecting to Televisions, Computers and Printers</b> .....	<b>79</b>
<b>Connecting to a TV</b> .....	<b>79</b>
<b>Connecting to a Computer</b> .....	<b>80</b>
Before Connecting the Camera.....	80
Transferring Images from a Camera to a Computer .....	81
<b>Connecting to a Printer</b> .....	<b>85</b>
Connecting the Camera and Printer.....	86
Printing Images One at a Time .....	87
Printing Multiple Images.....	88

---

<b>Basic Camera Setup</b> .....	<b>91</b>
<b>Setup Menu</b> .....	<b>91</b>
Welcome Screen .....	93
Time Zone and Date.....	94
Monitor Settings.....	98
Print Date.....	100
Electronic VR.....	101
Motion Detection .....	102
AF Assist.....	103
Sound Settings .....	103
Auto Off .....	104
Format Memory/Format Card .....	105
Language.....	106
Video Mode .....	106
Blink Warning .....	107
Reset All .....	109
Battery Type .....	111
Firmware Version .....	111

## Table of Contents

---

Notes on Camera Care and General Usage .....	112
Caring for the Camera .....	112
Cleaning .....	114
Storage .....	115
<hr/>	
Technical Notes .....	116
Optional Accessories .....	116
Approved Memory Cards .....	117
File and Folder Names .....	118
Error Messages .....	119
Troubleshooting .....	123
Specifications .....	128
Supported Standards .....	131
Index .....	132

## About This Manual

Thank you for your purchase of a Nikon COOLPIX L23 digital camera. This manual was written to help you enjoy taking pictures with your Nikon digital camera. Read this manual thoroughly before use, and keep it where all those who use the product will read it.

### Symbols and Conventions

To make it easier to find the information you need, the following symbols and conventions are used:



This icon marks cautions, information that should be read before use, to prevent damage to the camera.



This icon marks tips, additional information that may be helpful when using the camera.



This icon marks notes, information that should be read before using the camera.



This icon indicates that more information is available elsewhere in this manual or in the *Quick Start Guide*.

### Notations

- Secure Digital (SD) memory card, SDHC memory card, and SDXC memory card are referred to as “memory card.”
- The setting at the time of purchase is referred to as the “default setting.”
- The names of menu items displayed in the camera monitor, and the names of buttons or messages displayed in the computer monitor appear in bold.

### Screen Samples

In this manual, images are sometimes omitted from monitor display samples so that monitor indicators can be more clearly shown.

### Illustrations and Screen Display

Illustrations and text displays shown in this manual may differ from actual appearance or display.

### Memory Cards

Pictures taken with this camera can be stored in the camera’s internal memory or on removable memory cards. If a memory card is inserted, all new pictures will be stored on the memory card and delete, playback and format operations will apply only to the pictures on the memory card. The memory card must be removed before the internal memory can be formatted or used to store, delete or view pictures.

# Information and Precautions

## Life-Long Learning

As part of Nikon's "Life-Long Learning" commitment to ongoing product support and education, continually updated information is available online at the following sites:

- For users in the U.S.A.: <http://www.nikonusa.com/>
- For users in Europe and Africa: <http://www.europe-nikon.com/support/>
- For users in Asia, Oceania, and the Middle East: <http://www.nikon-asia.com/>

Visit these sites to keep up-to-date with the latest product information, tips, answers to frequently asked questions (FAQs), and general advice on digital imaging and photography. Additional information may be available from the Nikon representative in your area. See the URL below for contact information:

<http://imaging.nikon.com/>

## Use Only Nikon Brand Electronic Accessories

Nikon COOLPIX cameras are designed to the highest standards and include complex electronic circuitry. Only Nikon brand electronic accessories (including battery chargers, batteries and AC adapters) certified by Nikon specifically for use with this Nikon digital camera are engineered and proven to operate within the operational and safety requirements of this electronic circuitry.

THE USE OF NON-NIKON ELECTRONIC ACCESSORIES COULD DAMAGE THE CAMERA AND MAY VOID YOUR NIKON WARRANTY.

For more information about Nikon brand accessories, contact a local authorized Nikon dealer.

## Before Taking Important Pictures

Before taking pictures on important occasions (such as at weddings or before taking the camera on a trip), take a test shot to ensure that the camera is functioning normally. Nikon will not be held liable for damages or lost profits that may result from product malfunction.

## About the Manuals

- No part of the manuals included with this product may be reproduced, transmitted, transcribed, stored in a retrieval system, or translated into any language in any form, by any means, without Nikon's prior written permission.
- Nikon reserves the right to change the specifications of the hardware and software described in these manuals at any time and without prior notice.
- Nikon will not be held liable for any damages resulting from the use of this product.
- While every effort was made to ensure that the information in these manuals is accurate and complete, we would appreciate it were you to bring any errors or omissions to the attention of the Nikon representative in your area (address provided separately).

## Notice Concerning Prohibition of Copying or Reproduction

Note that simply being in possession of material that was digitally copied or reproduced by means of a scanner, digital camera or other device may be punishable by law.

- **Items prohibited by law from being copied or reproduced**

Do not copy or reproduce paper money, coins, securities, government bonds or local government bonds, even if such copies or reproductions are stamped "Sample". The copying or reproduction of paper money, coins, or securities which are circulated in a foreign country is prohibited. Unless the prior permission of the government was obtained, the copying or reproduction of unused postage stamps or post cards issued by the government is prohibited. The copying or reproduction of stamps issued by the government and of certified documents stipulated by law is prohibited.

- **Cautions on certain copies and reproductions**

The government has issued cautions on copies or reproductions of securities issued by private companies (shares, bills, checks, gift certificates, etc.), commuter passes or coupon tickets, except when a minimum of necessary copies are to be provided for business use by a company. Also, do not copy or reproduce passports issued by the government, licenses issued by public agencies and private groups, ID cards and tickets, such as passes and meal coupons.

- **Comply with copyright notices**

The copying or reproduction of copyrighted creative works such as books, music, paintings, woodcut prints, maps, drawings, movies and photographs is governed by national and international copyright laws. Do not use this product for the purpose of making illegal copies or to infringe copyright laws.

## Disposing of Data Storage Devices



Please note that deleting images or formatting data storage devices such as memory cards or built-in camera memory does not completely erase the original image data. Deleted files can sometimes be recovered from discarded storage devices using commercially available software, potentially resulting in the malicious use of personal image data. Ensuring the privacy of such data is the user's responsibility.

Before discarding a data storage device or transferring ownership to another person, erase all data using commercial deletion software, or format the device and then completely refill it with images containing no private information (for example, pictures of empty sky). Be sure to also replace any pictures selected for the welcome screen (📖 93). Care should be taken to avoid injury or damage to property when physically destroying data storage devices.

# Parts of the Camera

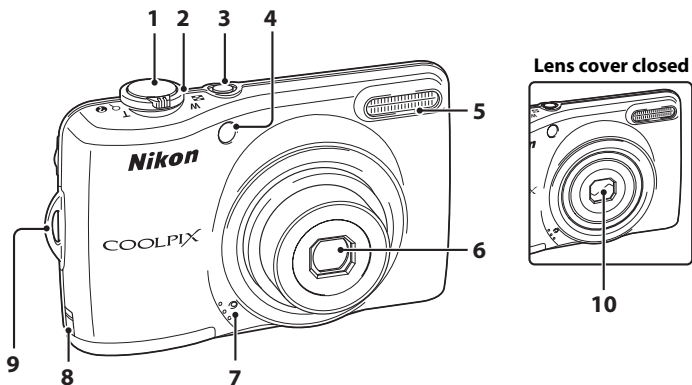
## The Camera Body



<b>1</b>	Shutter-release button .....	22
<b>2</b>	Zoom control .....	21
	<b>W</b> : Wide .....	21
	<b>T</b> : Tele .....	21
	 : Thumbnail playback .....	57
	 : Playback zoom .....	59
 : Help .....	32	
<b>3</b>	Power switch/Power-on lamp ....	18, 104
<b>4</b>	Self-timer lamp .....	28
	AF-assist illuminator .....	23, 103

<b>5</b>	Flash .....	26
<b>6</b>	Lens .....	114, 128
<b>7</b>	Built-in microphone .....	75
<b>8</b>	Power connector cover (for connecting optional AC adapter) .....	116
<b>9</b>	Eyelet for camera strap .....	4
<b>10</b>	Lens cover .....	112

## Attaching the Camera Strap

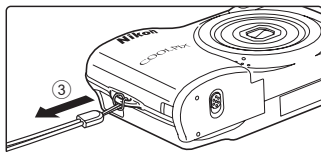
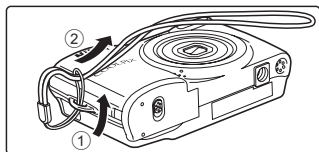

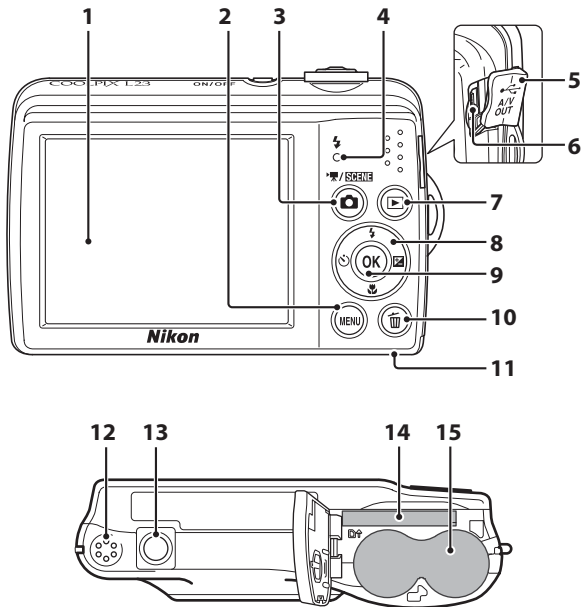

<b>1</b>	Monitor .....	6
<b>2</b>	<b>MENU</b> button .....	10, 48, 60, 76, 92
<b>3</b>	<b>Ⓢ</b> (shooting mode) button .....	8
<b>4</b>	Flash lamp .....	27
<b>5</b>	Pin cover .....	79, 81, 86
<b>6</b>	USB connector and audio/video output .....	79, 81, 86
<b>7</b>	<b>▶</b> (playback) button .....	8, 24
<b>8</b>	Multi selector .....	9

<b>9</b>	<b>OK</b> (apply selection) button .....	9
<b>10</b>	<b>ⓓ</b> (delete) button .....	25, 78
<b>11</b>	Battery-chamber/ memory card slot cover .....	12, 16
<b>12</b>	Speaker .....	78
<b>13</b>	Tripod socket	
<b>14</b>	Memory card slot .....	16
<b>15</b>	Battery-chamber .....	12

## The Monitor

The following indicators may appear in the monitor during shooting and playback (actual display varies with current camera settings).

The indicators and photo info displayed during shooting and playback will turn off after a few seconds (📖 98).

### Shooting

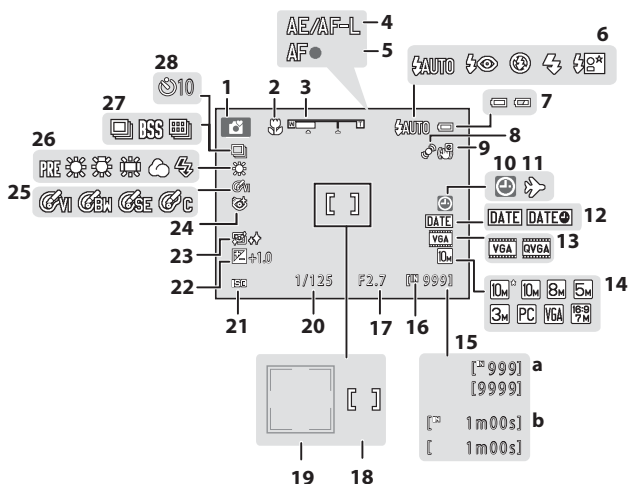

<b>1</b>	Shooting mode* .....	18, 30, 43, 46, 75	<b>15</b>	<b>a</b> Number of exposures remaining (still images) ...	18
<b>2</b>	Macro mode .....	47	<b>b</b>	Movie length .....	75
<b>3</b>	Zoom indicator .....	21, 47	<b>16</b>	Internal memory indicator .....	19
<b>4</b>	AE/AF-L indicator .....	42	<b>17</b>	Aperture .....	22
<b>5</b>	Focus indicator .....	22	<b>18</b>	Focus area .....	20, 22
<b>6</b>	Flash mode .....	26	<b>19</b>	Focus area (Face Detection) .....	20, 22
<b>7</b>	Battery level indicator .....	18	<b>20</b>	Shutter speed .....	22
<b>8</b>	Motion detection indicator .....	19, 102	<b>21</b>	ISO sensitivity .....	27
<b>9</b>	Electronic VR .....	101	<b>22</b>	Exposure compensation value .....	29
<b>10</b>	"Date not set" indicator .....	94, 119	<b>23</b>	Skin softening .....	45
<b>11</b>	Travel destination indicator .....	94	<b>24</b>	Blink proof .....	45
<b>12</b>	Print date .....	100	<b>25</b>	Color options .....	54
<b>13</b>	Movie options .....	77	<b>26</b>	White balance mode .....	51
<b>14</b>	Image mode .....	49	<b>27</b>	Continuous shooting mode .....	53
			<b>28</b>	Self-timer indicator .....	28

6 \* The displayed icons vary with the shooting mode.

## Playback

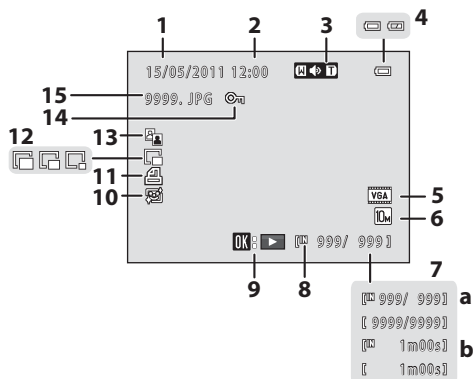



<b>1</b>	Date of recording .....	14	<b>8</b>	Internal memory indicator .....	24
<b>2</b>	Time of recording .....	14	<b>9</b>	Movie playback indicator .....	78
<b>3</b>	Volume .....	78	<b>10</b>	Skin softening icon .....	71
<b>4</b>	Battery level indicator .....	18	<b>11</b>	Print order icon .....	61
<b>5</b>	Movie options* .....	77	<b>12</b>	Small picture .....	72
<b>6</b>	Image mode* .....	49	<b>13</b>	D-Lighting icon .....	70
<b>7</b>	<b>a</b> Current frame number/ total number of frames .....	24	<b>14</b>	Protect icon .....	65
	<b>b</b> Movie length .....	78	<b>15</b>	File number and type .....	118

\* The displayed icons vary with the shooting mode.

## Basic Operations



### (Shooting Mode) Button



- When the  button is pressed in playback mode, the camera enters shooting mode.
- When the  button is pressed in shooting mode, the shooting-mode selection menu is displayed, which allows you to change the shooting mode ( 30).

### (Playback) Button



- During shooting mode, the camera enters the playback mode when the  button is pressed.
- If the camera is turned off, hold down the  button to turn the camera on in playback mode.

## The Multi Selector

Operate the multi selector by pressing it up ▲, down ▼, left ◀, right ▶ or by pressing the **OK** button.

### For Shooting

Display ⚡ (flash mode) menu (📖 26)/select the item above.

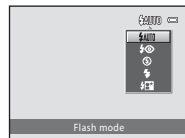
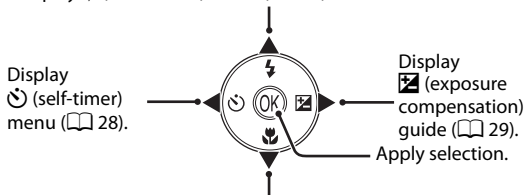

### For Playback

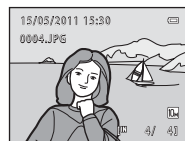
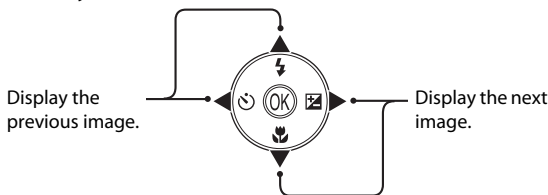

### For the Menu Screen

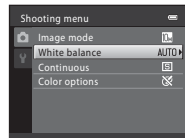
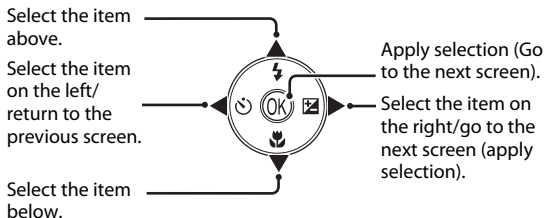

## Using Camera Menus

Press the **MENU** button (📖 5) to display the menu for the selected mode.

Use the multi selector (📖 9) to navigate the menus.

△ is displayed when previous menu items are available.

Tab for the menus available for the current mode

Tab for displaying the setup menu

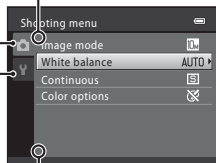

▽ is displayed when there are one or more menu items to follow.

### 1 Press the **MENU** button.

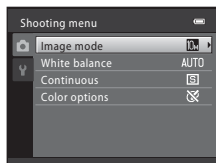
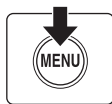

### 2 Press the multi selector ▲ or ▼ to choose an item, and then press ► or the **OK** button.

To change tabs, press ◀ (📖 11).

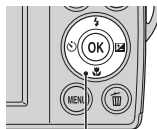

Multi selector

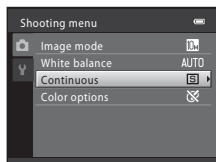

### 3 Press ▲ or ▼ to choose an item and press the **OK** button.

The setting is applied.

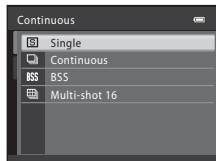

### 4 When setting is finished, press the **MENU** button.

The camera exits the menu display.

## Switching Between Tabs of Menu Screen

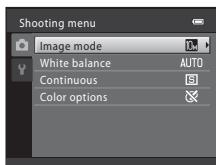

Press the multi selector ◀ to highlight the tab.

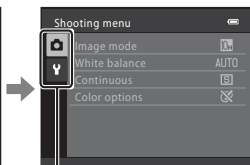

Press the multi selector ▲▼ to select a tab and press the  button or ▶.

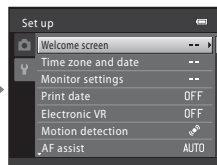

The selected menu will be displayed.

When using the following modes, you can display the tabs by pressing the multi selector ◀ while the menu is displayed.

- Easy auto mode, scene mode, and movie mode

## The Shutter-release Button

The camera features a two-stage shutter-release button. To set focus and exposure, press the shutter-release button halfway, stopping when you feel resistance. When the shutter-release button is pressed halfway, focus and exposure (shutter speed and aperture value) are set. Focus and exposure remain locked while the shutter-release button is pressed halfway.

While the shutter-release button is held in this position, release the shutter and take a picture by pressing the shutter-release button the rest of the way down. Do not use force when pressing the shutter-release button, as this may result in camera shake and blurred images.



Press halfway to set focus and exposure



Press the rest of the way down to take a picture

## Inserting the Batteries

### 1 Open the battery-chamber/memory card slot cover.

Before opening the battery-chamber/memory card slot cover, hold the camera upside down to prevent the batteries from falling out.

The camera, batteries or memory card may be hot immediately after using the camera. Observe caution when removing the batteries or memory card.

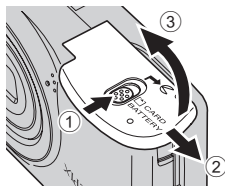

### 2 Inserting the Batteries.

Confirm that the positive (+) and negative (-) terminals are oriented correctly as described on the label at the entrance of the battery chamber, and insert the batteries.

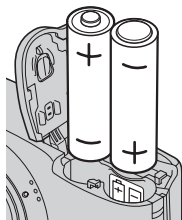

### 3 Close the battery-chamber/memory card slot cover.

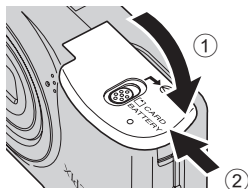

## Applicable Batteries



- Two LR6/L40 (AA-size) alkaline batteries (batteries supplied)
- Two FR6/L91 (AA-size) lithium batteries
- Two EN-MH2 Ni-MH (nickel metal hydride) rechargeable batteries

## Turning On and Off the Camera

Press the power switch to turn on the camera.

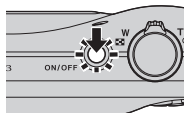
The power-on lamp (green) lights, and then the monitor turns on (the power-on lamp turns off when the monitor turns on). To turn off the camera, press the power switch again. When the camera turns off, both the power-on lamp and monitor turn off.



- If the camera is turned off, hold down the  button to turn the camera on in playback mode ( 24).

## ✓ Removing the Batteries

Turn the camera off and be sure that the power-on lamp and the monitor have turned off before opening the battery-chamber/memory card slot cover.

## ✓ Additional Precautions Regarding Batteries

- Read and follow the warnings and cautions (📖 iii, 113).
- Be sure to read and follow the warnings for the battery on page iii and the section, “The Battery” (📖 113), before using the battery.
- Do not combine old and new batteries or batteries of different makes or types.
- Batteries with the following defects cannot be used:



Batteries with peeling



Batteries with insulation that does not cover the area around the negative terminal

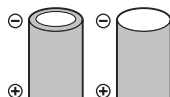

Batteries with a flat negative terminal

## ✓ Note for EN-MH1 Rechargeable Batteries, MH-70/71 Battery Charger

This camera can also use EN-MH1 Ni-MH rechargeable batteries.

Be sure to read and follow the warnings for the battery found in the section, “The Battery” (📖 113), before using the battery.

## ✓ Battery Type

By setting **Battery type** (📖 111) in the setup menu (📖 91) to match the type of batteries inserted in the camera, the batteries can perform more efficiently.

The default setting is the type of battery supplied with purchase. When any other type of battery is used, turn the camera on and change the setting (📖 111).

## 📎 Alkaline Batteries

Performance of alkaline batteries may vary greatly depending on the manufacturer. Choose a reliable brand.

## 📎 Alternative Power Sources

To power the camera continuously for extended periods, use an AC Adapter EH-65A (available separately) (📖 116). **Do not, under any circumstances, use another make or model of AC adapter.** Failure to observe this precaution could result in overheating or in damage to the camera.

## 📎 Power Saving Function (Auto Off)

If no operations are performed for a while, the monitor will turn off, the camera will enter standby mode, and the power-on lamp will blink. If no operations are performed for another three minutes, the camera will turn off automatically.

When the power-on lamp is blinking, pressing the following button will turn the monitor back on.

→ Power switch, shutter-release button, 📷 button or ▶ button

- In shooting or playback mode, the camera will enter standby mode in about 30 seconds (default setting).
- The time allowed to elapse before the camera enters standby mode can be changed from the **Auto off** option (📖 104) in the setup menu (📖 91).

# Setting Display Language, Date and Time

When the first time the camera is turned on, the language-selection screen and the date and time setting screen for the camera clock are displayed.

## 1 Press the power switch to turn on the camera.

The power-on lamp (green) will light, and then the monitor will turn on (the power-on lamp turns off when the monitor turns on).

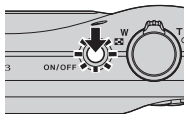

## 2 Press the multi selector ▲ or ▼ to choose the desired language and press the OK button.

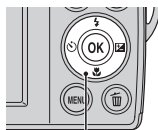

Multi selector

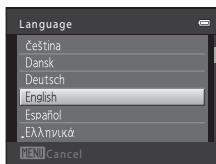

## 3 Press ▲ or ▼ to choose Yes and press the OK button.

To cancel the time zone and date setting, select **No**.

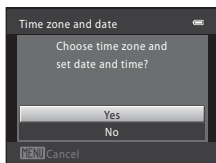

## 4 Press ◀ or ▶ to choose your home time zone (📖 97) and press the OK button.

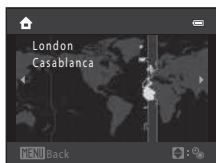

## 🔔 Daylight Saving Time

If daylight saving time is in effect, press ▲ to enable the daylight saving time function while setting the region in step 4.

When the daylight saving time function is enabled, 🌞 is displayed at the top of the monitor. Press ▼ to disable the daylight saving time function.

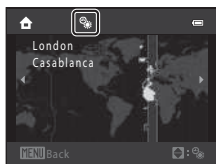

- 5** Press ▲ or ▼ to choose the date format and press the **OK** button or ►.

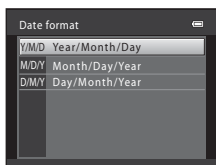

- 6** Press ▲, ◀, ▼, or ► to set the date and time and press the **OK** button.

Choose an item: Press ► or ◀ (to change between **D**, **M**, **Y**, **Hour**, or **Minute**).

Edit the highlighted item: Press ▲ or ▼.

Apply the setting: Choose **Minute** and press the **OK** button.

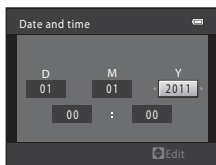

- 7** Press the **Ⓜ** button.

The lens extends and the shooting-mode selection screen is displayed.



- 8** When **Easy auto mode** is displayed, press the **OK** button.

The camera enters the shooting mode and you can take pictures in Easy auto mode (📖 18).

Press the multi selector ▲ or ▼ before pressing the **OK** button, to switch to another shooting mode (📖 30).

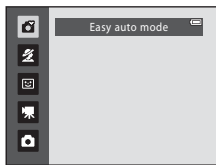

## **📌 Print date and Changing the Date and Time**

- To imprint the date on images while taking pictures, set **Print date** (📖 100) in the setup menu (📖 91) after the date and time have been set.
- To change the date and time settings of the camera clock, select **Time zone and date** (📖 94) in the setup menu (📖 91).

## Inserting Memory Cards

Data is saved in the camera's internal memory (approximately 22 MB) or on removable Secure Digital (SD) memory cards (commercially available;  117).

*If a memory card is inserted in the camera, images are automatically saved on the memory card and images saved to the memory card can be played back, deleted or transferred. Remove the memory card to save images in the internal memory, or play back, delete or transfer images from the internal memory.*

- 1** Confirm the power-on lamp and the monitor are off and open the battery-chamber/memory card slot cover.

Be sure to turn off the camera before opening the battery-chamber/memory card slot cover.

Before opening the battery-chamber/memory card slot cover, hold the camera upside down to prevent the batteries from falling out.

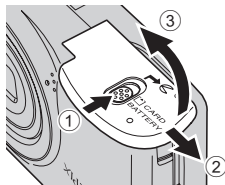

- 2** Insert the memory card.

Slide the memory card in until it clicks into place.

### Inserting Memory Cards

**Inserting the memory card upside down or backwards could damage the camera or the memory card.** Make sure that the memory card is correctly oriented.

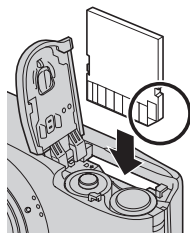

- 3** Close the battery-chamber/memory card slot cover.

## Removing Memory Cards

Turn the camera off and be sure that the power-on lamp and the monitor have turned off before opening the battery-chamber/memory card slot cover.

Press the card in (1) to partially eject the card, then remove the card by hand while being careful not to remove it at an angle (2).

- The camera, batteries or memory card may be hot immediately after using the camera. Observe caution when removing the batteries or memory card.

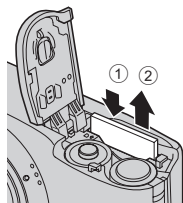

## ✓ Formatting Memory Cards

If the message shown on the right is displayed, the memory card must be formatted before use. **Note that formatting permanently deletes all images and other data on the memory card.** Be sure to make copies of any images you wish to keep before formatting the memory card.

To format, use the multi selector to select **Yes** and press the **OK** button. The confirmation dialog will be displayed. To start formatting, choose **Format** and press the **OK** button.

- Do not turn the camera off or open the battery-chamber/memory card slot cover until formatting is complete.
- **The first time you insert the memory cards used in other devices into the camera, be sure to format them using this camera** (📖 105).

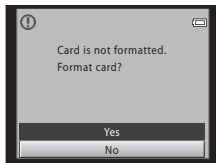

## ✓ The Write Protect Switch

When memory card switch is in the lock position, data cannot be written to, or deleted from, the memory card. If the switch is in the lock position, unlock it by sliding the switch to the write position to save or delete images, or to format the memory card.

Write protect switch

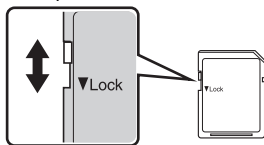

## ✓ Memory Cards

- Use only Secure Digital memory cards.
- Do not perform the following during formatting, while data is being written to or deleted from the memory card, or during data transfer to a computer. Failure to observe this precaution could result in the loss of data or in damage to the camera or memory card:
  - Insert or remove the card
  - Remove the batteries
  - Turn off the camera
  - Disconnect the AC adapter
- Do not format the memory card using a computer.
- Do not disassemble or modify.
- Do not drop, bend, or expose to water or strong physical shocks.
- Do not touch the metal terminals with your fingers or metal objects.
- Do not affix labels or stickers to the memory card.
- Do not leave in direct sunlight, closed vehicles or areas exposed to high temperatures.
- Do not expose to humidity, dust, or to corrosive gases.

## Step 1 Turn the Camera On and Select (Easy Auto) Mode

In (easy auto) mode, the camera automatically determines an appropriate shooting mode when you frame a picture, allowing you to easily take pictures using a shooting mode that suits the scene ( 31).

### 1 Press the power switch.

The lens extends and the monitor turns on.

Easy auto mode is set at the time of purchase. Proceed to step 4.

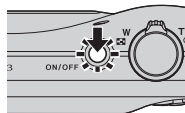

### 2 Press the button.



### 3 Press the multi selector or to choose Easy auto mode and press the button.

The camera enters (easy auto) mode.

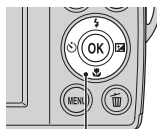

Multi selector

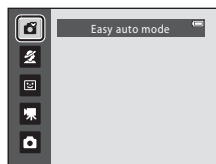

### 4 Check the battery level and the number of exposures remaining.

Battery level indicator

Display	Description
	Battery level high.
	Battery level low. Prepare to replace batteries.
Battery exhausted.	Cannot take pictures. Replace the batteries.

Battery level indicator

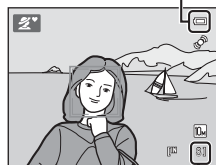

Number of exposures remaining







Number of Exposures Remaining

The number of pictures that can be taken is displayed.

The number of exposures remaining depends on the capacity of the internal memory or memory card and image mode setting ( 49).

## Indicators Displayed in (Easy Auto) Mode

### Shooting mode

In easy auto mode, the camera automatically selects , , , , , , or  mode according to the current subject and framing.

**Motion detection indicator**  
Reduce the blurring caused by subject or camera shake.

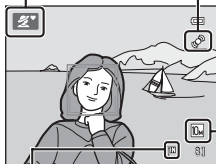

### Internal memory indicator

Images will be saved to internal memory (approximately 22 MB).  
When memory card is inserted,  is not displayed and images will be saved to memory card.

### Image mode

Display image size and quality set in the image mode menu.  
The default setting is  **3648x2736**.

- The indicators and photo info displayed during shooting and playback will turn off after a few seconds (📖 98).
- When the monitor has turned off in standby mode to save power (the power-on lamp is blinking), press any of the following buttons to turn it back on.  
→ Power switch, shutter-release button, or  button





## Functions Available in Easy Auto Mode

- When the camera is pointed at a person's face, the camera automatically detects the face and focuses on it (📖 22, 31).
- The flash setting can be set to  (off) (📖 26).
- The self-timer (📖 28) and exposure compensation (📖 29) are available.
- The macro mode button on the multi selector (📖 9, 47) is disabled. Changes to macro mode when the camera selects close-up scene mode.
- Press the **MENU** button to change the combination of image quality (compression) and image size in **Image mode** (📖 49).

## Motion Detection

See **Motion detection** (📖 102) in the setup menu (📖 91) for more information.

## Electronic Vibration Reduction

When the flash mode (📖 26) is set to  (off) or  (slow sync) while **Electronic VR** (📖 101) in the setup menu (📖 91) is set to **Auto**, the  icon may be displayed in the monitor. When shooting in conditions that lead to blurring caused by camera shake,  is displayed to indicate that the camera will reduce the effects of camera shake before saving images.

## Step 2 Frame a Picture

### 1 Ready the camera.

Hold the camera steadily in both hands.  
Keep fingers, hair and other objects away from the lens, flash, AF assist-illuminator and microphone.



When taking pictures in “tall” orientation, turn the camera so that the built-in flash is above the lens.



### 2 Frame the picture.

When the camera determines the scene mode, the shooting mode icon will change (📖 31).

When the camera detects a human face, that face will be framed by a yellow double border (AF area).

Up to 12 faces can be detected. If more than one face is detected, the face closest to the camera will be framed in the focus area by a double border, and the other faces will be framed by a single border.

When shooting non-human subjects or when no faces are detected, the camera will focus on the subject in the center of the frame. Position the main subject near the center of the monitor.

Shooting mode icon



### ✓ Easy Auto Mode

- The desired scene mode may not be selected in certain conditions. In this case, select another shooting mode.
- When digital zoom is in effect, the shooting mode is 📷.

## Using the Zoom

Use the zoom control to activate optical zoom.

Rotate the zoom control to **T** to zoom in on the subject.

Rotate the zoom control to **W** to zoom out.

- When the camera is turned on, the zoom is at the widest position.
- The zoom indicator is displayed at the top of the monitor when the zoom control is rotated.

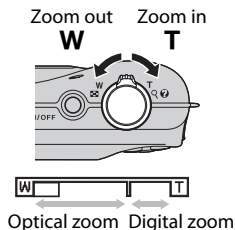

## Digital Zoom

When the camera is zoomed in to the maximum optical zoom position, rotating and holding the zoom control at **T** triggers digital zoom.

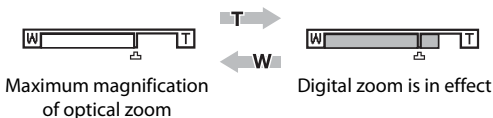

Digital zoom can magnify the subject up to about 4x beyond the maximum magnification of the optical zoom.



- The camera focuses in the center of the frame and the focus area is not displayed when digital zoom is in effect.

## Digital Zoom and Interpolation

Unlike optical zoom, digital zoom uses a digital imaging process known as interpolation to magnify images, resulting in slight deterioration of picture quality according to the image mode (📖 49) and digital zoom magnification.

Interpolation is applied at zoom positions beyond  when taking still images. When zoom is increased beyond the  position, interpolation is initiated and the zoom indicator turns yellow to indicate that interpolation is being applied.

The position of  moves to the right as image size decreases, allowing for confirmation of the zoom positions at which shooting without interpolation is possible at the current image mode setting.



## Step 3 Focus and Shoot

### 1 Press the shutter-release button halfway.

When the shutter-release button is pressed halfway (📖 11), the camera sets focus and exposure (shutter speed and aperture value). Focus and exposure remain locked while the shutter-release button is pressed halfway.

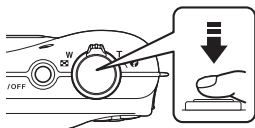

When a face is detected:

- The camera focuses on the face framed by the double border. When the subject is in focus, the double border glows green.



Shutter speed Aperture

When a face is not detected:

- The camera focuses on the subject in the center of the frame. When the subject is in focus, the focus area glows green.

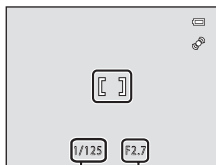

Shutter speed Aperture

The camera focuses in the center of the frame and the focus area is not displayed when digital zoom is in effect. Once focus has been acquired, the focus indicator (📖 6) glows green.

While the shutter-release button is pressed halfway, the focus area or focus indicator may blink red. This indicates that the camera is unable to focus. Modify the composition and press the shutter-release button halfway again.

### 2 Press the shutter-release button the rest of the way down.

The shutter is released and the image will be saved to the memory card or internal memory.



### ✔ During Saving

While images are being saved, the number of exposures remaining display will blink. **Do not open the battery-chamber/memory card slot cover.**

Removing the memory card or the batteries during saving may result in loss of data or in damage to the saved data, camera or card.

### ✔ Autofocus Performance

Autofocus may not perform as expected in the following situations. In some rare cases, the subject may not be in focus despite the fact that the focus area or the focus indicator glows green:

- Subject is very dark
- Objects of sharply differing brightness are included in the scene (e.g. the sun is behind the subject and the subject is in deep shadow)
- No contrast between the subject and surroundings (e.g. when the subject is standing in front of a white wall, wearing a white shirt)
- Several objects are at different distances from the camera (e.g. the subject is inside a cage)
- Subjects with repeating patterns (window blinds, buildings with multiple rows of similarly shaped windows, etc.)
- Subject is moving rapidly

In these situations, try pressing the shutter-release button halfway again to refocus, several times if necessary. If the subject is still not in focus, select auto mode and use focus lock (📖 46) to take the picture by first focusing on an object that is the same distance from the camera as the desired subject.

### ✔ Note on Face Detection

See “Notes on Face Detection” (📖 31) for more information.

### ✍ AF-assist Illuminator and Flash





If the subject is dimly lit, the AF-assist illuminator (📖 103) may light when the shutter-release button is pressed halfway, and the flash (📖 26) may fire when the shutter-release button is pressed all the way down.

## Step 4 Viewing and Deleting Images

### Viewing Images (Playback Mode)



Press the  (playback) button.

The last image captured will be displayed in full-frame playback mode.

Press the multi selector  or  to display the previous image. Press  or  to display the next image.

Images may be displayed briefly at low resolution while being read from the memory card or internal memory.

Press the  button to switch to shooting mode.

When  is displayed, images saved in the internal memory will be displayed. When memory card is inserted,  is not displayed and images saved on the memory card will be displayed.

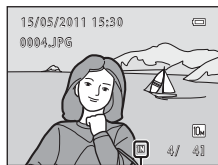
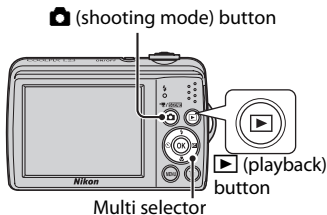

Internal memory indicator

#### When the Monitor Has Turned Off to Save Power

When the power-on lamp is blinking, pressing the  button will turn the monitor back on ( 104).

#### Playback Mode

See "More on Playback" ( 56) and "Editing Image" ( 69) for more information.

#### Power On by Pressing the Button

When the camera is off, hold down the  button to turn on the camera in playback mode. The lens will not extend.

#### Viewing Images



Images captured using face detection ( 22) will be rotated and displayed automatically according to the orientation of the faces detected, in full-frame playback mode.

## Deleting Unwanted Images

- 1 Press the  button to delete the image currently displayed in the monitor.

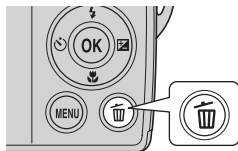
To exit without deleting, press the **MENU** button.



- 2 Press the multi selector  or  to choose the desired deletion method and press the **OK** button.



**Current image:** The image currently displayed is deleted.

**Erase selected images:** Multiple images can be selected and deleted.

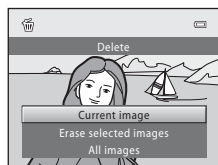

→ “Operating the Erase Selected Images Screen”

**All images:** All images are deleted.





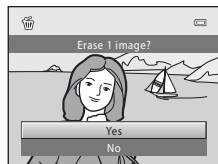

- 3 Press  or  to choose **Yes** and press the **OK** button.

Deleted images cannot be recovered.

To cancel, press  or  to select **No** and press the **OK** button.





## Operating the Erase Selected Images Screen

- 1 Press the multi selector  or  to choose an image to be deleted and press  to add  to the image and mark it for deletion.

To undo the selection, press  to remove .

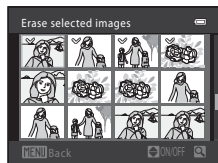
Rotate the zoom control ( 4) to **T** () to switch back to full-frame playback or **W** () to display thumbnails.



- 2 Add  to all desired images and then press the **OK** button to confirm the selection.

A confirmation dialog is displayed. Follow the instructions displayed in the monitor.

### Notes on Deletion

- Deleted images cannot be restored. Transfer important images to a computer before deleting them.
- Protected images cannot be deleted ( 65).

### Deleting the Last Image Captured While in Shooting Mode

In shooting mode, press the  button to delete the last image captured.

# Using the Flash

The flash mode allows you to specify the settings according to shooting conditions.

- The flash has a range of approx. 0.3-5.0 m (1 ft.-16 ft.) when the camera is zoomed out all the way, and 0.6-2.0 m (2 ft.-6 ft. 7 in.) when the maximum optical zoom is applied.
- Note that when using easy auto mode (📖 18), only **⚡AUTO Auto** (default setting) and **🚫 Off** are available. When **⚡AUTO Auto** is applied, the camera automatically selects the optimum flash mode setting for the scene mode it has selected.
- When using Auto mode (📖 46), certain scene modes (📖 32), or smart portrait mode (📖 43), the following flash modes are available.

<b>⚡AUTO</b>	<b>Auto</b>
	Flash fires automatically when lighting is poor.
<b>👁️</b>	<b>Auto with red-eye reduction</b>
	Reduces “red-eye” in portraits (📖 27).
<b>🚫</b>	<b>Off</b>
	Flash will not fire even when lighting is poor.
<b>🔋</b>	<b>Fill flash</b>
	Flash fires when a picture is taken. Use to “fill-in” (illuminate) shadows and back-lit subjects.
<b>📷</b>	<b>Slow sync</b>
	Auto flash mode is combined with slow shutter speed. Suitable for taking portraits with the night landscape as the background. Flash illuminates main subject; slow shutter speeds are used to capture background at night or under dim light.

## Selecting a Flash Mode

- 1 Press **⚡** (flash mode) on the multi selector.  
The flash mode menu is displayed.



- 2 Press the multi selector **▲** or **▼** to select a mode and press the **OK** button.

The icon for the selected flash mode is displayed.

When **⚡AUTO** (auto) is applied, **⚡AUTO** is only displayed for a few seconds, regardless of the **Photo info** settings (📖 98).

If a setting is not applied by pressing the **OK** button within a few seconds, the selection will be cancelled.

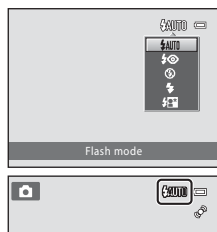

## ✔ Shooting When Lighting Is Poor and the Flash Is Disabled (🔋)

- Use of a tripod is recommended to stabilize the camera during shooting and avoid the effects of camera shake.
- **ISO** may be displayed in the monitor. When **ISO** is displayed, images captured may be slightly mottled due to increased ISO sensitivity.

## ✔ Note on Using the Flash

When using the flash, reflections from dust particles in the air may appear as bright spots in images. To reduce these reflections, set the flash to 🚫 (Off).

## 📌 The Flash Lamp

The flash lamp indicates flash status when the shutter-release button is pressed halfway.

- **On:** Flash will fire when picture is taken.
- **Blinks:** Flash charging. Wait a few seconds and try again.
- **Off:** Flash will not fire when picture is taken.

If the battery is low, the monitor display will turn off, and remain off, until the flash is fully charged.

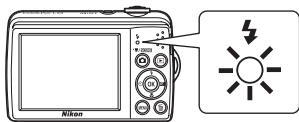

## 📌 The Flash Mode Setting

The default flash mode setting varies with shooting mode (📖 30).

- 📷 (easy auto) mode: ⚡AUTO Auto
- Scene mode: Varies with the selected scene mode (📖 32)
- 📷 (Smart portrait) mode: ⚡AUTO Auto (when blink proof is turned off), fixed at 🚫 Off (when blink proof is turned on) (📖 43)
- 📷 (auto) mode: ⚡AUTO Auto

Flash cannot be used simultaneously with certain features. → “Camera Settings that Cannot Be Set at the Same Time” (📖 55)

When the shooting mode is 📷 (auto) mode (📖 46), the changed flash setting is saved even if the camera is turned off.

## 📌 Red-eye Reduction

This camera uses advanced red-eye reduction (“In-Camera Red-Eye Fix”).

Pre-flashes are fired repeatedly at low intensity before the main flash, reducing the red-eye effect. Additionally, if the camera detects red eye while saving an image, the affected area will be processed to reduce red-eye before the image is saved.

Note the followings when shooting.

- Because pre-flashes are fired, there is a slight lag between when the shutter-release button is pressed and when the shutter is released.
- More time than usual is required to save images.
- Red-eye reduction may not produce the desired results in some situations.
- In extremely rare instances, areas not subject to red-eye may be affected by red-eye reduction processing; in these cases, choose another flash mode and try again.

## Taking Pictures with the Self-timer

The self-timer is useful for self-portraits or reducing the effects of camera shake that occur when the shutter-release button is pressed.

When using the self-timer, pictures are taken 10 seconds after the shutter-release button is pressed. When using the self-timer, use of a tripod is recommended.

### 1 Press (self-timer) on the multi selector.

The self-timer menu is displayed.



### 2 Press the multi selector or to select **ON** and press the button.

The self-timer icon () 10 is displayed.

If a setting is not applied by pressing the  button within a few seconds, the selection will be cancelled.

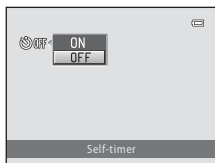

### 3 Frame the picture and press the shutter-release button halfway.

Focus and exposure will be set.



### 4 Press the shutter-release button the rest of the way down.

The self-timer starts and the number of seconds remaining until the shutter is released is displayed in the monitor. The self-timer lamp blinks while the timer is counting down. About one second before the shutter is released, the lamp stops blinking and glows steadily.

When the shutter is released, the self-timer will be set to **OFF**.

To stop the timer before a picture is taken, press the shutter-release button again.





# Adjusting the Brightness: Exposure Compensation

The brightness of the entire image can be increased or decreased by setting the exposure compensation when taking a picture.

- 1** Press  (exposure compensation) on the multi selector.

The exposure compensation guide is displayed.



- 2** Press the multi selector  or  to select a compensation value.

To make the subject brighter, adjust the exposure compensation to the "+" side.

To make the subject darker, adjust the exposure compensation to the "-" side.

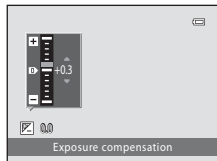

- 3** Press the  button.

If a setting is not applied by pressing the  button within a few seconds, the selection will be cancelled.

When set to any value other than **0.0**,  and the value are displayed.

- 4** Press the shutter-release button to shoot.

To turn off exposure compensation, repeat from step 1 and set the value to **0.0**, then press the  button.

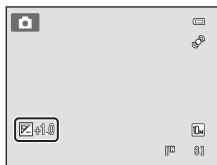

## Exposure Compensation Value

The exposure compensation setting applied in  (auto) mode ( 46) is saved in the camera's memory even after the camera is turned off.

## Selecting Shooting Mode

The following shooting modes can be selected.

 **Easy auto mode**  18



By simply framing a picture, the camera automatically selects the optimum scene mode for simpler shooting.

 **Scene**  32

Camera settings are automatically optimized for the selected scene type.

 **Smart portrait**  43

The camera detects a smiling face to shoot the face automatically. The skin softening option can be used to smooth skin tones of human faces.

 **Movie**  75

Movies with sound can be recorded.

 **Auto mode**  46





You can change the flash mode, use macro mode (for close-ups), etc., and take pictures. You can also select to shoot bursts of pictures continuously.

### 1 Press in shooting mode.

The shooting-mode selection menu is displayed.



### 2 Press the multi selector or to select a shooting mode.

When a scene mode is selected (the second icon from the top), the scene type can be changed by pressing the  button. Press , , , or  to select a scene.

To return to the current shooting mode without switching shooting modes, press  or the shutter-release button.

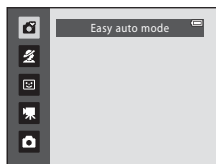







### 3 Press the button.

The camera enters the selected shooting mode.

# Easy Auto Mode

## Automatic Scene Selection

The camera automatically selects one of the following scenes when you point the camera at a subject.

-  Auto mode (general use)
-  Portrait (📖 33)
-  Landscape (📖 33)
-  Night portrait (📖 34)
-  Night landscape (📖 36)
-  Close-up (📖 37)
-  Backlighting (📖 39)

## Notes on Face Detection

- Depending on shooting conditions, such as whether or not the subject is facing the camera, faces may not be detected.

The camera may be unable to detect faces in the following situations:

- When faces are partially hidden by sunglasses or other obstructions
- When faces take up too much or too little of the frame
- When there are multiple people in the frame, the face on which the camera focuses depends on a variety of shooting conditions, such as whether or not the subject is facing the camera.
- In some cases, included those noted in “Autofocus Performance” (📖 23), autofocus may not perform as expected, and the subject may not be in focus despite the fact that the double border glows green. When the camera is unable to focus, use another mode, such as  (auto) mode, focus on another subject positioned at the same distance from the camera as the actual portrait subject, and use focus lock (📖 46).

## Shooting Suited for the Scene (Scene Mode)

Camera settings are automatically optimized for the selected subject type. The following scene modes are available.

Portrait	Landscape	Sports	Night portrait
Party/indoor	Beach	Snow	Sunset
Dusk/dawn	Night landscape	Close-up	Food
Museum	Fireworks show	Black and white copy	Backlighting
Panorama assist			

### Selecting a Scene Mode

- 1 Press the button in shooting mode and press the multi selector or to select scene mode.

The icon of the last scene mode used is displayed. (Portrait) is the default setting (📖 33).

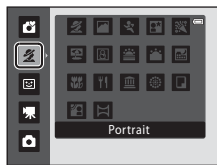

- 2 Press , press , , , or to select a scene mode, then press the button.

The shooting mode screen for the selected scene is displayed.

Scene mode types and characteristics → 📖 33

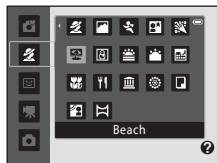

- 3 Frame the subject and shoot.







### Image Mode

Press the **MENU** button to set the combination of image quality (compression) and image size in **Image mode** (📖 49). If the image mode setting is changed, the new image mode setting is also applied to other shooting modes (except movie mode).

### Viewing the Description of Each Scene (Help)

Choose a scene type from the scene selection screen (step 2) and rotate the zoom control (📖 4) to **T** (🔍) to view a description of that scene. To return to the original screen, rotate the zoom control to **T** (🔍) again.

## Choosing a Scene and Shooting (Scene Mode Types and Characteristics)

The following icons are used for descriptions in this section: , flash mode (📖 26), , self-timer (📖 28), , macro mode (📖 47), , exposure compensation (📖 29).

### Portrait

Use this mode for portraits.

- If the camera detects a face, it focuses on the face. See “Face Detection” (📖 22) for more information.
- If more than one face is detected, the camera focuses on the face closest to the camera.
- The camera softens skin tones (in up to three faces) by applying the skin softening function before saving images (📖 45).
- If no faces are detected, the camera focuses on the subject in the center of the frame.
- Digital zoom is not available.



\* Default setting can be modified.

### Landscape

Use this mode for vivid landscapes and cityscapes.

- Camera focuses at infinity. The focus area or focus indicator (📖 6) always glows green when the shutter-release button is pressed halfway. Note, however, that objects in the foreground may not always be in focus.
- The AF-assist illuminator (📖 103) does not light.





\* Default setting can be modified.

## Shooting Suited for the Scene (Scene Mode)

### Sports

Use this mode when taking sports-related pictures at a sporting event, etc. Use this mode to capture the instantaneous movements in moving subjects by shooting a continuous series of images (burst).



- The camera focuses on the subject in the center of the frame. The camera focuses continuously until the shutter-release button is pressed halfway to lock the focus. The sound of lens drive movement will be heard while the camera focuses.
- While the shutter-release button is held all the way down, images can be continuously captured at approximately 1.4 frame per second up to four frames (when image mode is set to  **3648x2736**).
- The focus, exposure, and white balance settings are fixed at the values for the first image in each series.
- The maximum frame rate with continuous shooting may vary depending upon the current image mode setting and the memory card used.
- The AF-assist illuminator ( 103) does not light.

			Off		Off		0.0*
---	---	---	-----	---	-----	---	------



\* Default setting can be modified.

### Night portrait



Use this mode to achieve a natural balance between the main subject and background lighting in portraits taken at night. Flash is used to illuminate the subject while maintaining the mood of the background.



- If the camera detects a person's face, the camera will focus on that person (face detection:  22).
- If more than one face is detected, the camera focuses on the face closest to the camera.
- The camera softens skin tones (in up to three faces) by applying the skin softening function before saving images ( 45).
- If no faces are detected, the camera focuses on the subject in the center of the frame.
- Digital zoom is not available.

	 <sup>1</sup>		Off <sup>2</sup>		Off		0.0 <sup>2</sup>
---	--	---	------------------	---	-----	---	------------------

<sup>1</sup> The flash mode setting is fixed at fill flash with slow sync with red-eye reduction.

<sup>2</sup> Default setting can be modified.

### Party/indoor

Suitable for taking pictures in parties. Captures the effects of candlelight and other indoor background lighting.

- The camera focuses on the subject in the center of the frame.
- As images are easily affected by camera shake, hold the camera steadily. In a dark place, the use of a tripod is recommended.



<sup>1</sup> Slow sync with red-eye reduction flash mode may be used. Default setting can be modified.

<sup>2</sup> Default setting can be modified.

### Beach

Captures the brightness of such subjects as beaches or sunlit expanses of water.

- The camera focuses on the subject in the center of the frame.



\* Default setting can be modified.

### Snow

Captures the brightness of sunlit snow.

- The camera focuses on the subject in the center of the frame.



\* Default setting can be modified.

## Shooting Suited for the Scene (Scene Mode)

### Sunset



Preserves the deep hues seen in sunsets and sunrises.

- The camera focuses on the subject in the center of the frame.





\* Default setting can be modified.

### Dusk/dawn



Preserves the colors seen in the weak natural light before sunrise or after sunset.

- Camera focuses at infinity. The focus area or focus indicator ( 6) always glows green when the shutter-release button is pressed halfway. Note, however, that objects in the foreground may not always be in focus.
- The AF-assist illuminator ( 103) does not light.





\* Default setting can be modified.

### Night landscape



Slow shutter speeds are used to produce stunning night landscapes.

- Camera focuses at infinity. The focus area or focus indicator ( 6) always glows green when the shutter-release button is pressed halfway. Note, however, that objects in the foreground may not always be in focus.
- The AF-assist illuminator ( 103) does not light.







\* Default setting can be modified.

: For those scene modes with , use of a tripod is recommended.

 Close-up

Photograph flowers, insects and other small objects at close range.

- Macro mode ( 47) will turn on and the zoom will automatically move to the closest possible shooting position.
- The closest distance at which the camera can focus varies depending on the zoom position. Use this mode in the zoom range where  or the zoom indicator glows green. The camera can focus on objects as close as about 10 cm (4 in.) at the widest zoom position, and as close as about 3 cm (1.2 in.) at the position where  is displayed.
- The camera focuses on the subject in the center of the frame. Use focus lock to frame the picture on an object not in the center of the frame ( 46).
- The camera focuses continuously until the shutter-release button is pressed halfway to lock the focus.
- As images are easily affected by camera shake, hold the camera steadily.



	 AUTO*		Off*		On		0.0*
---	---	---	------	---	----	---	------

\* Default setting can be modified. Note that the flash may be unable to light entire subject at distances of less than 60 cm (2 ft.).

## Shooting Suited for the Scene (Scene Mode)

### Food

Use this mode when taking pictures of food.

- Macro mode (📖 47) will turn on and the zoom will automatically move to the closest possible shooting position.
- The closest distance at which the camera can focus varies depending on the zoom position. Use this mode in the zoom range where 📷 or the zoom indicator glows green. The camera can focus on objects as close as about 10 cm (4 in.) at the widest zoom position, and as close as about 3 cm (1.2 in.) at the position where 📷 is displayed.
- You can adjust the hue using the slider displayed on the left side of the monitor. Press the multi selector ▲ to increase the amount of red, or ▼ to increase the amount of blue. Adjustments made to the hue setting are saved in the camera's memory even after the camera is turned off.
- The camera focuses on the subject in the center of the frame. Use focus lock to frame the picture on an object not in the center of the frame (📖 46).
- The camera focuses continuously until the shutter-release button is pressed halfway to lock the focus.
- As images are easily affected by camera shake, hold the camera steadily.

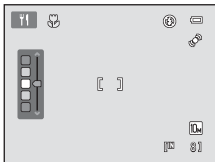

\* Default setting can be modified.

### Museum

Use indoors where flash photography is prohibited (for example, in museums and art galleries) or in other settings in which you do not want to use the flash.

- The camera focuses on the subject in the center of the frame.
- BSS (best shot selector) can be used to shoot (📖 53).
- As images are easily affected by camera shake, hold the camera steadily.
- The AF-assist illuminator (📖 103) does not light.



\* Default setting can be modified.

### Fireworks show



Slow shutter speeds are used to capture the expanding burst of light from fireworks.

- Camera focuses at infinity. When the shutter-release button is pressed halfway, the focus indicator (📖 6) always glows green. Note, however, that objects in the foreground may not always be in focus.
- The AF-assist illuminator (📖 103) does not light.



### Black and white copy

Provides clear images of text or drawings on a white board or in print.

- The camera focuses on the subject in the center of the frame.
- Use macro mode (📖 47) to focus at short ranges.
- Colored text and drawings may not show up well.



\* Default setting can be modified.

### Backlighting

Use when light is coming from behind your subject, throwing features or details into shadow. The flash fires automatically to “fill in” (illuminate) shadows.

- The camera focuses on the subject in the center of the frame.



\* Default setting can be modified.

: For those scene modes with , use of a tripod is recommended.

## Shooting Suited for the Scene (Scene Mode)

### Panorama assist





Use when taking a series of pictures that will later be joined to form a single panorama using the supplied Panorama Maker 5 software. See “Taking Pictures for a Panorama” (📖 41) for details.



\* Default setting can be modified.

## Taking Pictures for a Panorama





The camera focuses on the subject in the center of the frame. Use a tripod for best results.



- 1** Press the  button in shooting mode and then press the multi selector to select  **Panorama assist** (📖 32).

The panorama direction icon () is displayed to show the direction in which images will be joined.



- 2** Use the multi selector to choose the direction and press the  button.

Select how images will be joined together in the completed panorama; right () , left () , up () or down () .

The yellow panorama direction icon () is displayed to the direction pressed and the direction is fixed when the  button is pressed. The white fixed direction  is displayed.

Apply flash mode (📖 26), self-timer (📖 28), macro mode (📖 47) and exposure compensation (📖 29) settings with this step, if necessary.

Press the  button to reselect the direction.



- 3** Frame the first portion of the panorama scene and take the first picture.

The first image is superimposed in the first third of the monitor.



- 4** Take the second picture.

Frame the next image so that one third of the frame overlaps the first image, and press the shutter-release button.

Repeat until you have taken the necessary number of pictures to complete the scene.



### 5 Press the **OK** button when shooting is completed.

The camera returns to step 2.



### **✔** Panorama Assist

Set flash mode, self-timer, macro mode and exposure compensation before taking the first picture. They cannot be changed after the first picture is taken. Images cannot be deleted, nor can zoom or **Image mode** setting (📖 49) be adjusted after the first picture is taken.

The panorama series is terminated if the camera enters standby mode with the auto off function (📖 104) during shooting. Setting the time allowed to elapse before the auto off function is enabled to a longer setting is recommended.

### **💡** Note on AE/AF-L

When using panorama assist mode, all images captured in a panorama series have the same white balance, exposure, and focus settings as the first image captured.

When the first picture is taken, AE/AF-L is displayed to indicate that exposure, white balance, and focus are locked.



### **💡** Panorama Maker 5

Install Panorama Maker 5 from the supplied ViewNX 2 CD.





Transfer images to a computer (📖 81) and use Panorama Maker 5 (📖 84) to join them in a single panorama.

### **💡** More Information

See, "File and Folder Names" (📖 118) for more information.

## Capturing Smiling Faces Automatically (Smart Portrait Mode)

The camera detects a smiling face to shoot the face automatically. The skin softening option can be used to smooth skin tones of human faces.

- 1** Press the  button and then press the multi selector  or  to select , and press the  button.

The camera enters smart portrait mode.

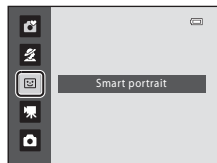

- 2** Frame the picture.

Point the camera at the subject.

If the camera detects a person's face, the face will be framed by a double yellow border in the focus area, and when the face comes into focus, the double border will for a moment turn green and the focus will be locked.

Up to three faces will be detected. When the camera detects more than one face, the double border (focus area) is displayed around the face closest to the center of the frame, and single borders around the others.

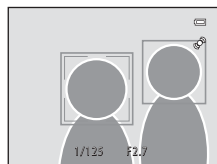

- 3** The shutter is automatically released.

If the camera detects the smiling face of the person framed by a double border, the shutter is automatically released.

Each time the shutter is released, the camera repeats automatic shooting by face detection and smile detection.

- 4** Exit this shooting mode.

Exit automatic shooting with the smile detection feature by turning the power off or by pressing the  button to change to another shooting mode.

## Capturing Smiling Faces Automatically (Smart Portrait Mode)

### Notes on Smart Portrait

- Digital zoom is not available.
- Under some shooting conditions, the camera may be unable to detect faces or detect smiles.
- See “Notes on Face Detection” (📖 31) for more information.

### Notes on Skin Softening

- When taking pictures with skin softening, more time than usual may be required to save images.
- In some shooting conditions, facial skin tones may not be smoothed or parts other than face may be modified even though the camera detects a face. If the desired results cannot be achieved, set **Skin softening** to **Off** and try again.
- The skin softening function cannot be set to Off in Portrait and Night portrait scene modes.
- Skin softening can also be applied on saved images (📖 71).

### Auto Off (Standby Mode) When Using Smart Portrait Mode

When using smart portrait mode, auto off (📖 104) will turn the camera off if no operations are performed in the following situations:

- The camera does not detect any faces.
- The camera detected the face but cannot detect a smiling face.

### Self-Timer Lamp Blinking

The self-timer lamp blinks when the camera detects a face, and it flickers immediately after the shutter is released.

### Releasing the Shutter Manually

Pictures can also be taken by pressing the shutter-release button. If the camera does not detect any faces, the camera focuses on the subject in the center of the frame.

### Functions Available in Smart Portrait Mode

- The flash cannot be used when **Blink proof** is set to **On**. When **Blink proof** is set to **Off**, a flash mode (📖 26) is set to **⚡AUTO** (auto) (this can be changed).
- The self-timer and macro mode are not available.
- The exposure compensation (📖 29) is available.
- Press the **MENU** button to display the  (smart portrait) menu and adjust **Image mode**, **Skin softening** or **Blink proof** (📖 45).

### More Information

See, “Autofocus” (📖 23) for more information.

## Changing the Smart Portrait Settings

After displaying the 😊 (smart portrait) mode shooting screen (📖 43), press the **MENU** button (📖 10) to set the following options in the smart portrait menu.

- Use the multi selector to choose and apply settings (📖 9).
- To exit the shooting menu, press the **MENU** button.

### Image mode

Choose the image mode (combination of image size and compression rate) at which images are saved (📖 49).

Changes made to the image mode setting apply to all shooting modes (except movie mode).

### Skin softening

- **On** (default setting): When the shutter is released, the camera detects a human face (up to three faces) and softens skin tones through image enhancement before saving images.
- **Off**: The skin softening function is set to Off.
- Skin softening settings can be confirmed by the icon displayed on the shooting screen (📖 6). When **Off** is selected, no icon is displayed. The degree of skin softening effect cannot be confirmed on the subject on the shooting screen. View the image to confirm it after shooting.







### Blink proof

When **On** is selected, the camera releases the shutter twice every time an image is captured and saves only one image in which the subject's eyes are open compared to the other.

- If an image in which the subject's eyes may have closed is saved, the message on the right is displayed for a few seconds.
- If **On** is selected, the flash is disabled.
- The default setting is **Off**.
- Blink proof settings can be confirmed in the monitor when shooting (📖 6). When **Off** is selected, no icon is displayed.



# Auto Mode

In  (auto) mode, macro mode ( 47) and exposure compensation ( 29) can be applied and pictures can be taken using the flash mode ( 26) and self-timer ( 28). Pressing the **MENU** button in  (auto) mode allows you to set the items in the shooting menu ( 48) according to shooting conditions.





## 1 Press the button.

The shooting-mode selection menu will be displayed.



## 2 Press the multi selector or to choose and press the button.

The camera enters  (auto) mode.

Set the flash ( 26), self-timer ( 28), exposure compensation ( 29) and macro mode ( 47) according to shooting conditions.

By pressing the **MENU** button, you can also set the items in the shooting menu ( 48) according to shooting conditions.

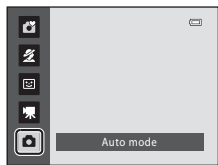

## 3 Frame the subject and shoot.

Camera focuses on subject in center of frame.

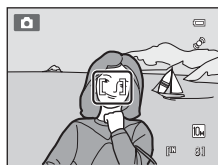

### Focus Lock

When the camera focuses on an object in the center of the frame, you can use focus lock to focus on an off-center subject.

- Be sure that the distance between the camera and the subject does not change while focus is locked.
- When the shutter-release button is pressed halfway, exposure is locked.



Position the subject in the center of the frame.



Press the shutter-release button halfway.



Confirm that the focus area is green.





Continue holding down the shutter-release button halfway and recompose the picture.



Press the shutter-release button the rest of the way down.

## Macro Mode

Macro mode is used for taking pictures of objects as close as 3 cm (1.2 in.). Note that the flash may be unable to light entire subject at distances of less than 60 cm (2 ft.).

When using  (auto) mode, follow the procedure below. Macro mode can also be used with some scene modes ( 37, 38, 39).

### 1 Press (macro mode) on the multi selector.

The macro mode menu is displayed.



### 2 Press the multi selector or to select **ON** and press the .

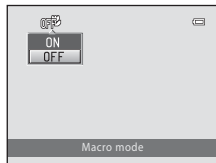

The macro mode icon () is displayed.

If a setting is not applied by pressing the  button within a few seconds, the selection will be cancelled.



### 3 Rotate the zoom control until the zoom position reaches the position where and the zoom indicator glow green.

The closest distance at which the camera can focus varies depending on the zoom position.



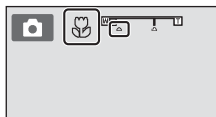



Use this mode in the zoom range where  or the zoom indicator glows green. The camera can focus on objects as close as about 10 cm (4 in.) at the widest zoom position, and as close as about 3 cm (1.2 in.) at the position where  is displayed.



## Autofocus

When using macro mode, the camera focuses continuously until the shutter-release button is pressed halfway to lock the focus. A sound will be heard while the camera focuses.

## The Macro Mode Setting

-  (easy auto) mode: Changes to macro mode when the camera selects . The macro mode button cannot be used.
- Scene mode: Varies with the selected scene mode ( 32). Macro mode is turned on when  **Close-up** or  **Food** is selected in scene mode.
-  (smart portrait) mode: Macro mode cannot be used.
- The macro mode setting applied in  (auto) mode is saved in the camera's memory even after the camera is turned off.

## Changing (Auto) Mode Settings (Shooting Menu)

While shooting in  (auto) mode ( 46), the shooting menu contains the following options.

### Image mode 49

Choose the image mode (combination of image size and compression rate) at which images are saved. This setting can be changed when using any shooting mode.

### White balance 51

In order to make the colors in images appear as they do to the eye, set white balance to suit the light source.



### Continuous 53

Change settings to Continuous or BSS (best shot selector).

### Color options 54

Make colors more vivid or save images in monochrome.

## Displaying the Shooting Menu

Set the camera to  (auto) mode ( 46).

Press the **MENU** button to display the shooting menu.

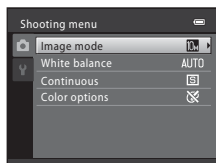
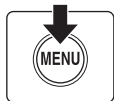

- Use the multi selector to choose and apply settings ( 9).
- To exit the shooting menu, press the **MENU** button.









## Camera Settings That Cannot Be Applied at the Same Time

Some functions may not be set at the same time ( 55).

## Image Mode (Image Quality/Image Size)

 (auto) → MENU (shooting menu) → Image mode

Image mode refers to the combination of image size and image quality (compression) at which images are saved. Choose the image mode best suited to the manner in which images will be used and the capacity of the internal memory or memory card. The higher the image mode setting, the larger the size at which it can be printed or displayed without appearing noticeably grainy, but limiting the number of images that can be saved.

Setting	Size (pixels)	Description
 3648×2736★	3648 × 2736	Highest quality; suitable for enlargements or high-quality prints. The compression ratio is approximately 1:4.
 3648×2736 (default setting)	3648 × 2736	Best choice in most situations. The compression ratio is approximately 1:8.
 3264×2448	3264 × 2448	
 2592×1944	2592 × 1944	
 2048×1536	2048 × 1536	Smaller size allows more images to be saved. The compression ratio is approximately 1:8.
 1024×768	1024 × 768	Suited to display on a computer monitor. The compression ratio is approximately 1:8.
 640×480	640 × 480	Suited to full-screen display on a television with an aspect ratio of 4:3, or distribution by e-mail. The compression ratio is approximately 1:8.
 3584×2016	3584 × 2016	Images with an aspect ratio of 16:9 can be captured. The compression ratio is approximately 1:8.









The icon for the current setting is displayed in the monitor in shooting and playback modes (📖 6, 7).

### Image Mode

- When using shooting modes other than  (auto) mode, this setting can be changed by pressing the MENU button. The setting is also applied to other shooting modes (except movie mode).
- This feature cannot be used simultaneously with certain features. → “Camera Settings that Cannot Be Set at the Same Time” (📖 55)

## Number of Exposures Remaining

The following table lists the approximate number of images that can be saved in internal memory and on a 4 GB memory card. Note that the number of images that can be saved will differ depending on the composition of the image (due to JPEG compression). In addition, this number may differ depending on the make of memory card, even if the capacity for the memory card is the same.

Image mode	Internal memory (Approx. 22 MB)	Memory card <sup>1</sup> (4 GB)	Print size <sup>2</sup> (cm/in.)
 3648×2736★	4	780	31 × 23/12 × 9
 3648×2736	8	1540	31 × 23/12 × 9
 3264×2448	11	1910	28 × 21/11 × 8.3
 2592×1944	17	2980	22 × 16/8.7 × 6.3
 2048×1536	27	4640	17 × 13/6.7 × 5.1
 1024×768	90	15000	9 × 7/3.5 × 2.8
 640×480	167	27700	5 × 4/2 × 1.6
 3584×2016	12	2110	30 × 17/12 × 6.5

<sup>1</sup> If the number of exposures remaining is 10,000 or more, the number of exposures remaining display shows "9999."

<sup>2</sup> When the printer resolution is set to 300 dpi.

Print sizes are calculated by dividing the number of pixels by printer resolution (dpi) and multiplying by 2.54 cm (1 in.). However, at the same image size, images printed at higher resolutions will print smaller than the size indicated, and those printed at lower resolutions will print larger than the size indicated.

## White Balance (Adjusting Hue)

 (auto) → MENU (shooting menu) → White balance

The color of light reflected from an object varies with the color of the light source. The human brain is able to adapt to changes in the color of the light source, with the result that white objects appear white whether seen in the shade, direct sunlight, or under incandescent lighting. Digital cameras can mimic this adjustment by processing images according to the color of the light source. This is known as “white balance”.

Although the default setting, **Auto**, can be used under most types of lighting, you can apply the white balance setting suited to a particular light source to achieve more accurate results.

### **AUTO** Auto (default setting)

White balance automatically adjusted to suit lighting conditions. Best choice in most situations.

### **PRE** Preset manual

Useful when shooting under unusual lighting. See “Preset Manual” for more information( 52).

### Daylight

White balance adjusted for direct sunlight.

### Incandescent

Use under incandescent lighting.

### Fluorescent

Use under most types of fluorescent lighting.

### Cloudy



Use when taking pictures under overcast skies.

### Flash

Use with the flash mode.

The icon for the current setting is displayed in the monitor ( 6). No icon is displayed when **Auto** is selected.

## White Balance

- This feature cannot be used simultaneously with certain features. → “Camera Settings that Cannot Be Set at the Same Time” ( 55)
- At white-balance settings other than **Auto** or **Flash**, turn the flash off (  26).

## Preset Manual

Preset manual is used with mixed lighting or to compensate for light sources with a strong color cast when the desired effect has not been achieved with white balance settings like **Auto** and **Incandescent** (for example, to make images shot under a lamp with a red shade look as though they had been shot under white light).

Use the procedure below to measure the white balance value under the lighting used during shooting.

- 1 Place a white or gray reference object under the lighting that will be used during shooting.

- 2 Display the shooting menu (📖 48), use the multi selector to set **White balance to PRE Preset manual**, then press the **OK** button.

The camera zooms in to the position for measuring white balance.

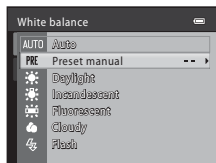

- 3 Choose **Measure**.

To apply the most recently measured white balance value, choose **Cancel** and press the **OK** button. The white balance setting will not be measured again and the most recently measured value will be set.

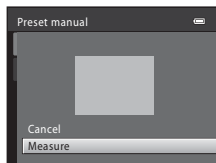

- 4 Frame the reference object in the measuring window.

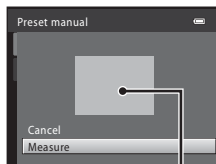

Reference object frame

- 5 Press the **OK** button to measure a value for preset manual.

The shutter is released and the new white balance value is set (no image is saved).

### ✔ Note on Preset Manual

The camera cannot measure a white balance value for when the flash fires. When shooting with the flash, set **White balance to Auto or Flash**.

## Continuous

 (auto) → MENU (shooting menu) → Continuous

Change settings to Continuous or BSS (best shot selector).

### Single (default setting)

One image is captured each time shutter-release button is pressed.

### Continuous

While the shutter-release button is held all the way down, images can be continuously captured at approximately 1.4 frames per second up to four frames (when image mode is set to  **3648×2736**).

### BSS (Best Shot Selector)

The “best shot selector” is recommended when shooting with the flash off or the camera zoomed in, or in other situations in which inadvertent motion can result in blurred images.

When BSS is on, the camera shoots up to ten images while the shutter-release button is held down. The sharpest image in the series is automatically selected and saved.

### Multi-shot 16

Each time the shutter-release button is pressed all the way down, 16 images are captured at about 30 frames per second (fps) and the camera arranges them in a single image. Images are captured with the **Image mode** fixed at  (image size is 2560 × 1920 pixels).

- Digital zoom is not available.

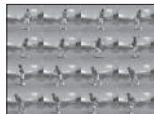

The icon for the current setting is displayed in the monitor when the camera is in shooting mode ( 6). No icon is displayed when **Single** is selected.

## Notes on Continuous Shooting

- If set to **Continuous**, **BSS**, or **Multi-shot 16**, the flash cannot be used. The focus, exposure, and white balance settings are fixed at the values for the first image in each series.
- The maximum frame rate with continuous shooting may vary, depending upon the current image mode setting, the memory card used, and shooting conditions.
- This feature cannot be used simultaneously with certain features. → “Camera Settings that Cannot Be Set at the Same Time” ( 55)

## Note on BSS

**BSS** is best suited to situations where the subject is not moving. When shooting moving subjects or when the composition of the picture changes while shooting, the desired results may not be achieved.

### **Note on Multi-shot 16**

Smear (📖 115) visible in the monitor when shooting with **Multi-shot 16** is visible in the saved image. Avoiding bright objects such as the sun, reflections of the sun, and electric lights is recommended to avoid smear effects.

---

## Color Options

 (auto) → MENU (shooting menu) → Color options

Make colors more vivid or save images in monochrome.

 **Standard color (default setting)**  
Use for images exhibiting natural color.

 **Vivid color**  
Use to achieve a vivid, “photoprint” effect.

 **Black-and-white**  
Save images in black-and-white.

 **Sepia**  
Save images in sepia tones.

 **Cyanotype**  
Save images in cyan-blue monochrome.

The icon for the current setting is displayed in the monitor when the camera is in shooting mode (📖 6). No icon is displayed when **Standard color** is selected. Monitor color tones also change depending upon the setting.

### **Note on Color Options**



This feature cannot be used simultaneously with certain features. → “Camera Settings that Cannot Be Set at the Same Time” (📖 55)

## Camera Settings that Cannot Be Set at the Same Time

Certain settings in the shooting menu cannot be used with other functions.







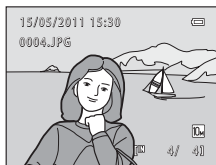











Restricted Functions	Setting	Description
Flash mode	Continuous (📖 53)	When using <b>Continuous</b> , <b>BSS</b> , or <b>Multi-shot 16</b> , the flash cannot be used.
Digital zoom	Continuous (📖 53)	When using <b>Multi-shot 16</b> , the digital zoom cannot be used.
Image mode	Continuous (📖 53)	When using <b>Multi-shot 16</b> , <b>Image mode</b> is fixed at <b>5M</b> (image size is 2560 × 1920 pixels).
White balance	Color options (📖 54)	When using <b>Black-and-white</b> , <b>Sepia</b> , or <b>Cyanotype</b> , the <b>White balance</b> setting is fixed at <b>Auto</b> .
Continuous	Self-timer (📖 28)	When using the self-timer, the setting is fixed at <b>Single</b> .
Electronic VR	Continuous (📖 53)	When using <b>Continuous</b> , <b>BSS</b> , or <b>Multi-shot 16</b> , electronic VR is disabled.
Motion detection	Continuous (📖 53)	When using <b>Multi-shot 16</b> , <b>Motion detection</b> is not enabled.

## Full-frame Operation



Press  button during shooting to switch to playback mode and view images ( 24).



The following operations can be performed while viewing images in full-frame.

Function	Control	Description	
Choose images		Press    or  to view the previous or next image. Hold down the multi-selector  ,  ,  or  to quickly scan through images.	9
Switch to thumbnail playback/calendar playback mode	<b>W</b> 	Display 4, 9, or 16 image thumbnails. While viewing 16 image thumbnails, rotate the zoom control to <b>W</b>  to switch to calendar display.	57, 58
Playback zoom	<b>T</b> 	The image can be enlarged up to about 10x. Press  to return to full-frame playback.	59
Movie Playback		Play the selected movie.	78
Deleting Images		Select a deletion method and delete images.	25
Menu Display	<b>MENU</b>	Display the playback menu.	60
Switch to shooting mode		Press the  button.	8

### Changing the Orientation (Vertical/Horizontal) of Images

Image orientation can be changed after taking a picture using **Rotate image** ( 67) in the playback menu ( 60).

## Viewing Multiple Images: Thumbnail Playback

Rotate the zoom control to **W** (📐) in full-frame playback mode (📖 56) to display images in “contact sheets” of thumbnail images.

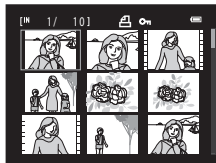

The following operations can be performed while thumbnails are displayed.

Function	Control	Description	📖
Choose images		Press the multi selector ▲, ▼, ◀ or ▶.	9
Increase the number of images displayed/ apply the calendar display	<b>W</b> (📐)	Rotate the zoom control to <b>W</b> (📐) to change the number of frames displayed from 4 → 9 → 16, or to display the calendar. When the calendar is displayed, you can select images to view based on the day they were captured (📖 58). Rotate the zoom control to <b>T</b> (📷) to return to thumbnail display mode.	—
Reduce the number of frames displayed	<b>T</b> (📷)	Rotate the zoom control to <b>T</b> (📷) to change the number of frames displayed from 16 → 9 → 4. While 4 frames are displayed, rotate the zoom control to <b>T</b> (📷) again to return to full-frame display mode.	—
Deleting Images		Select a deletion method and delete images.	25
Switch to full-frame playback		Press the <b>OK</b> button.	24
Switch to shooting mode		Press the <b>📷</b> button.	8

## Thumbnail Playback Mode Display

While images selected for **Print order** (📖 61) and **Protect** (📖 65) are chosen, the icons shown on the right are displayed with them. Movies are displayed as film frames.

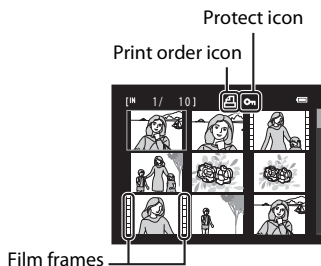



## Calendar Display

Rotate the zoom control to **W** (🗄️) when the images are displayed in 16-thumbnail (📖 57) in playback mode to switch to calendar display.

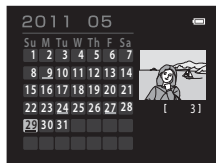
You can select images to view based on the day they were captured. Days containing images have a yellow line under them.



The following operations are available in calendar display.

Function	Control	Description	
Choose date		Press the multi selector ▲, ▼, ◀, or ▶.	9
Switch to full-frame playback		The first image for that date will be displayed full-frame.	24
Switch to thumbnail display	<b>T</b> (🗄️)	Rotate the zoom control to <b>T</b> (🗄️).	–

## Calendar Display

- Images captured when the camera's date is not set are treated as images captured on January 1, 2011.
- The  and **MENU** buttons are not available during calendar display.

## Taking a Closer Look: Playback Zoom

Rotating the zoom control to **T** (Q) during full-frame playback mode (📖 24) zooms the current image, with the center of the image displayed in the monitor.

- The guide displayed in the right bottom in the monitor will show which part of the image is currently displayed.



The following operations can be performed while images are zoomed in.

Function	Control	Description	📖
Zoom in	<b>T</b> (Q)	Rotate the zoom control to <b>T</b> (Q). Images can be magnified by up to 10x.	–
Zoom out	<b>W</b> (📐)	Rotate the zoom control to <b>W</b> (📐). When the magnification ratio reaches 1x, the display returns to full-frame playback mode.	–
View other areas of image		Press the multi selector <b>▲</b> , <b>▼</b> , <b>◀</b> , or <b>▶</b> to scroll to areas of the image not visible in the monitor.	9
Switch to full-frame playback	<b>OK</b>	Press the <b>OK</b> button.	24
Crop image	<b>MENU</b>	Create a cropped copy with only the enlarged portion and save the copy as a separate file.	73
Deleting Images		Select a deletion method and delete images.	25
Switch to shooting mode		Press the  button.	8

### Images Captured Using Face Detection









When zooming in on an image captured using face detection (📖 22) by rotating the zoom control to **T** (Q) in full-frame playback mode, the image will be enlarged with the face detected during shooting at the center of the monitor.

- If several faces are detected, the image will be enlarged using the face which was focused on during shooting time as the centralized point, and pressing the multi selector **▲**, **▼**, **◀** or **▶** will enable you to switch between the people's faces.
- Rotating the zoom control to **T** (Q) or **W** (📐) further can change the magnification ratio and the images will be zoomed in as usual.



# Playback Menu

The following functions are available in playback mode.

	<b>D-Lighting</b> <span style="float: right;">70</span>
	Enhances brightness and contrast in dark portions of images.
	<b>Skin softening</b> <span style="float: right;">71</span>
	Make facial skin tones softer.
	<b>Print order</b> <span style="float: right;">61</span>
	Select images to print and the number of copies for each.
	<b>Slide show</b> <span style="float: right;">64</span>
	View images saved in the internal memory or on a memory card in an automatic slide show.
	<b>Protect</b> <span style="float: right;">65</span>
	Protect selected images from accidental deletion.
	<b>Rotate image</b> <span style="float: right;">67</span>
	Change the orientation of an image.
	<b>Small picture</b> <span style="float: right;">72</span>
	Create a small-sized copy of the current image.
	<b>Copy</b> <span style="float: right;">68</span>
	Copy files between memory card and internal memory.

More on Playback

## Displaying the Playback Menu

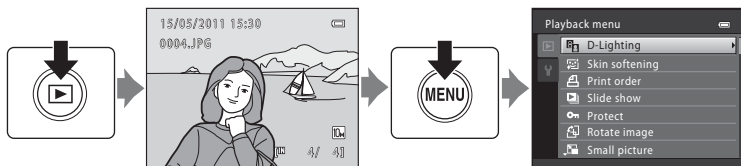

Press the  button to enter playback mode (76).

Display the playback menu by pressing the **MENU** button.





- Use the multi selector to choose and apply settings (79).
- To exit the playback menu, press the **MENU** button.

## Print Order

 button (playback mode) → MENU (playback menu) →  Print order

Before printing images saved on a memory card using one of the methods listed below, you can create a digital “print order” that specifies which images should be printed and how many copies of each image should be printed, and save this information on the memory card.

- Printing with a DPOF-compatible ( 131) printer that features a memory card slot
- Printing using a digital photo lab that supports DPOF
- Printing by connecting the camera ( 85) to a PictBridge-compatible ( 131) printer (If the memory card is removed from the camera, you can create the print order for images saved in the internal memory and print images according to the print order.)

### 1 Press the MENU button in playback mode.

The playback menu is displayed.

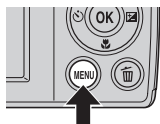

### 2 Use the multi selector to choose **Print order** and press the button.

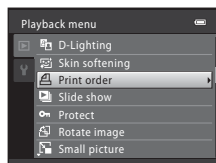

### 3 Choose **Select images** and press the button.

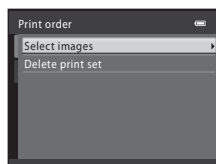

## 4 Choose the images (up to 99) and the number of copies (up to nine) for each.

Press the multi selector ◀ or ▶ to choose the desired images. Press ▲ or ▼ to set the number of copies for each.

Images selected for printing can be identified by the check mark and the numeral indicating the number of copies to be printed. Images for which no copies have been specified will not be printed.

Rotate the zoom control to **T** (Q) to switch back to full-frame playback or **W** (Q) to display 12 thumbnails.

Press the **OK** button when setting is complete.





## 5 Choose whether or not to also print shooting date and shooting information.

Choose **Date** and press the **OK** button to print date of recording on all images in the print order.

Choose **Info** and press the **OK** button to print shooting information (shutter speed and aperture) on all images in the print order.

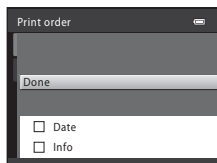
Choose **Done** and press the **OK** button to complete the print order and exit.



Images specified for **Print order** are indicated during playback by the  icon.

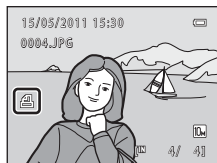

## ✓ Notes on Printing Shooting Date and Shooting Information

When the **Date** and **Info** options are enabled in the print order menu, shooting date and shooting information are printed on images when a DPOF-compatible printer (📖 131) which supports printing of shooting date and shooting information is used.

- Shooting information cannot be printed when the camera is connected directly to a printer, via the supplied USB cable, for DPOF printing (📖 89).
- Note that **Date** and **Info** settings are reset each time the **Print order** option is displayed.
- The date and time printed on images with DPOF printing when **Time zone and date** in the print order menu is enabled, are those recorded with the image when it was captured. Changing the **Date and time** or **Time zone** using the **Time zone and date** option in the setup menu after an image has been captured has no effect on the date printed on the image.





## ✎ Deleting All Print Orders

Choose **Delete print set** in step 3 (📖 61) of the print order procedure and press the **OK** button to delete print orders for all images.

## 🕒 Print Date



The shooting date and time can be imprinted in images at the time of shooting by using **Print date** (📖 100) in the setup menu. This information can be printed even from printers that do not support printing of date and time (📖 62). Only the date of print date and time on images will be printed, even if **Print order** is enabled with date selected in the print order screen.

## Slide Show

 button (playback mode) → MENU (playback menu) →  Slide show



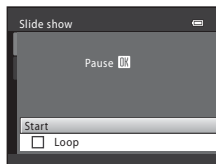

View images saved in the internal memory or on a memory card in an automatic slide show.

### 1 Use the multi selector to choose **Start** and press the button.

To repeat the slide show automatically, select **Loop** and press the  button before selecting **Start**. The check mark () will be added to the loop option when enabled.



### 2 The slide show begins.

During playback, press the multi selector  to display the next image and  to display the previous image (press and hold  or  to fast-forward or rewind, respectively).

To end or pause the slide show, press the  button.



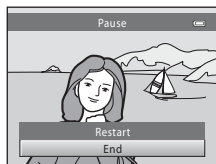

### 3 Choose **End** or **Restart**.

The screen shown on the right is displayed when the slide show has ended or is paused. Choose **End** and press the  button to return to the playback menu. Choose **Restart** to play the slide show again.



## Notes on Slide Show

- Only the first frame of movies ( 78) included in slide shows is displayed.
- Even if **Loop** is selected, the monitor can continuously display the slide show for up to 30 minutes ( 104).

## Protect

 button (playback mode) → MENU (playback menu) →  Protect

Protect selected images from accidental deletion.

You can turn protection on and off for images selected in the image selection screen.

→ “Selecting Multiple Images” (📖 66)

Note, however, that formatting the camera’s internal memory or the memory card will permanently erase protected files (📖 105).

Protected images can be identified by the  icon (📖 7, 57) in playback mode.

## Selecting Multiple Images

When using one of the following features, a screen shown on the right is displayed when selecting images.

- Print order: **Select images** (📖 61)
- Protect (📖 65)
- Rotate image (📖 67)
- Copy: **Selected images** (📖 68)
- Welcome screen: **Select an image** (📖 93)
- Delete image: **Erase selected images** (📖 25)



Follow the procedure described below to choose the images.

- 1 Press the multi selector ◀ or ▶ to choose the desired image.

Rotate the zoom control to **T** (🔍) to switch to full-frame playback. Rotate the zoom control to **W** (📄) to switch back to 12 thumbnail display.

Only one image can be selected for **Welcome screen** and **Rotate image**. Proceed to step 3.



- 2 Press ▲ or ▼ to select or deselect (or specify the number of copies).



When **ON** is selected, a check mark (☑) is displayed. Repeat steps 1 and 2 to select additional images.



- 3 To fix the selection of images, press the **OK** button.

When **Selected images** is selected, a confirmation dialog is displayed. Follow the instructions displayed in the monitor.





## Rotate Image

 button (playback mode) → MENU (playback menu) →  Rotate image

Set the image orientation (vertical or horizontal frame) displayed on the camera monitor after the images are captured.

Images can be rotated 90° clockwise or counterclockwise.

Images that were saved in the portrait (vertical) orientation can be rotated up to 180° in either direction.

Select an image in the image selection screen ( 66), and press the  button to display the Rotate image screen. Press the multi selector  or  to rotate the image 90°.



Press the  button to select the displayed direction and the vertical / horizontal position data will be saved on the image.

## Copy: Copying Between Memory Card and Internal Memory

button (playback mode) → MENU (playback menu) → Copy

Copy images between the internal memory and a memory card.

- 1 Select an option from the copy screen using the multi selector and press the **OK** button.

 → : Copy images from internal memory to memory card.

 → : Copy images from memory card to internal memory.

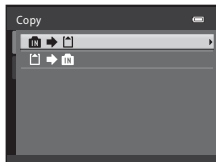

- 2 Choose the copy option and press the **OK** button.

**Selected images:** Copy images selected from the image selection screen ( 66).

**All images:** Copy all images.

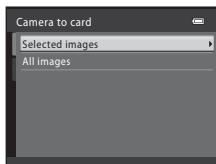

### Notes on Copying Images

- JPEG- and AVI-format files can be copied. Files saved in any other format cannot be copied.
- Images captured with another make of camera or that have been modified on a computer cannot be copied.
- When copying images for which **Print order** ( 61) options are enabled, the print order settings are not copied. However, when copying images for which **Protect** ( 65) is enabled, the protect setting is copied.

### Memory contains no images. Message

If there are no images saved on a memory card inserted in the camera when playback mode is applied, the message **Memory contains no images.** will be displayed. Press the **MENU** button to display the copy option screen, and copy the images saved in the camera's internal memory to the memory card.

### More Information

File and Folder Names → 118

## Image Editing Function

The editing features described below are available. Use the camera to edit images in-camera and save them as separate files (📖 118).

Editing function	Description
D-Lighting (📖 70)	Create a copy of the current image with enhanced brightness and contrast, brightening dark portions of the image.
Skin softening (📖 71)	Make facial skin tones softer.
Small picture (📖 72)	Create a small copy of images suitable for use as e-mail attachments, etc.
Crop (📖 73)	Crop a portion of the image. Use to zoom in on a subject or arrange a composition.

### ✔ Notes on In-camera Editing

- Only images captured with the COOLPIX L23 can be edited with this camera.
- Images captured at an **Image mode** (📖 49) setting of **3584x2016** cannot be edited using the skin softening (📖 71) and small picture (📖 72) functions.
- If no face is detected in an image, a copy cannot be created using the skin softening function (📖 71).
- When using a different model of digital camera, images edited with this camera may not be displayed properly and may not be able to be transferred to a computer.
- Editing functions are not available when there is not enough free space in the internal memory or on the memory card.

### 🔪 Restrictions on Image Editing

The following limitations apply when editing images that were created by editing.

Copies Created By:	Can Be Edited By:
D-Lighting	The skin softening, small picture, or crop function can be added.
Skin softening	The D-Lighting, small picture, or crop function can be added.
Small picture Crop	Additional editing is not possible.

- Copies created by the editing functions cannot be edited again using the same edit function.
- When combining the small picture or crop function and another editing function, use the small picture and crop functions after other editing functions have been applied.
- Skin softening can also be applied on images captured with the skin softening option (📖 45).



### 📁 Original Images and Edited Copies

- Copies created with editing functions are not deleted even if the original images are deleted. The original images are not deleted even if copies created with editing functions are deleted.
- Edited copies are saved with the same shooting date and time as the original.
- Edited copies do not retain the **Print order** (📖 61) and **Protect** (📖 65) settings of the original.

## Editing Images

### **D-Lighting: Enhancing Brightness and Contrast**

D-Lighting can be used to create copies with enhanced brightness and contrast, brightening dark portions of an image. Enhanced copies are saved as separate files.

- 1** Choose the desired image in full-frame playback mode ( 56) or thumbnail playback mode ( 57) and press the **MENU** button.

The playback menu will be shown.

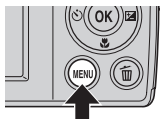

- 2** Use the multi selector to choose  **D-Lighting** and press the **OK** button.

The original version will be shown on the left and the edited version will be shown on the right.

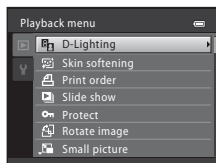

- 3** Choose **OK** and press the **OK** button.

A new, edited copy is created.

To cancel, select **Cancel** and press the **OK** button.

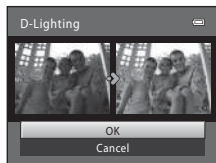

D-Lighting copies can be identified by the  icon displayed during playback.





### **More Information**

See, "File and Folder Names" ( 118) for more information.

## Skin Softening: Softening Skin Tones

The camera detects faces in images and creates a copy with softer facial skin tones. Copies created using the skin softening function are saved as separate files.

- 1 Choose the desired image in full-frame playback mode ( 56) or thumbnail playback mode ( 57) and press the **MENU** button.

The playback menu is displayed.

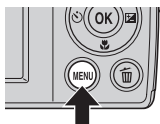



- 2 Use the multi selector to choose  **Skin softening** and press the **OK** button.

The screen for selecting the degree of softening is displayed.

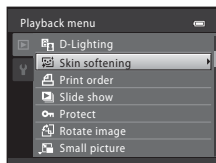
If no faces are detected in the image, an alert is displayed and the camera returns to the playback menu.



- 3 Press the multi selector  or  to choose the degree of softening and press the **OK** button.

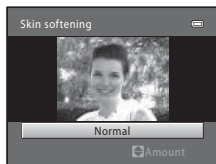

The confirmation dialog is displayed with the face to which skin softening was applied enlarged at the center of the monitor.

To exit without saving the copy, press the **MENU** button.



- 4 Check the preview of the copy.

Skin tones in up to 12 faces, in the order of that closest to the center of the frame, are softened.

If more than one face was softened, press the multi selector  or  to display a different face.

Press the **MENU** button to adjust the degree of softening. The monitor display returns to that shown in step 3.

When the **OK** button is pressed, a new, edited copy is created.

Copies created with the skin softening function can be recognized by the  icon displayed in playback mode.

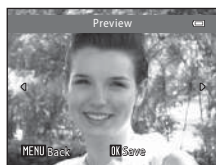



### **Note on Skin Softening**



Depending upon the direction in which faces are looking, or the brightness of faces, the camera may be unable to accurately recognize faces, or the skin softening function may not perform as expected.

### **More Information**

See "File and Folder Names" ( 118) for more information.

## **Small Picture: Decreasing Image Size**

Create a small copy of the current image. Suitable for uploading to web sites or sending by e-mail. The following sizes are available:  **640×480**,  **320×240**, and  **160×120**. Small copies are saved as JPEG files with a compression ratio of 1:16.

- 1 Choose the desired image in full-frame playback mode ( 56) or thumbnail playback mode ( 57) and press the **MENU** button.

The playback menu will be shown.

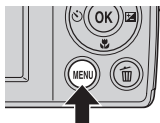

- 2 Use the multi selector to choose  **Small picture** and press the **OK** button.

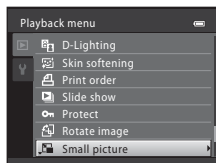

- 3 Choose the desired copy size and press the **OK** button.

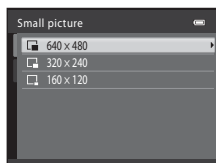

- 4 Choose **Yes** and press the **OK** button.

A new, smaller copy is created.

To cancel, select **No** and press the **OK** button.

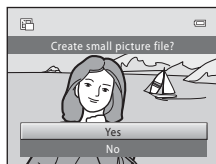

The copy is displayed with a black frame.



### **More Information**

## ✂ Crop: Creating a Cropped Copy

This function is only available when **MENU**  is displayed in the monitor with playback zoom ( 59) enabled. Cropped copies are saved as separate files.

- 1 Rotate the zoom control to **T** () in full-frame playback ( 56) mode to zoom in on an image.

To crop an image captured with an **Image mode** set to  **3584×2016**, zoom in on the image until the black bars displayed at the top and bottom of the monitor both disappear. The cropped image will be displayed in the aspect ratio of 4:3.

To crop an image displayed in "tall" (portrait) orientation, zoom in on the image until the black bars displayed on the both sides of the monitor disappear.

The cropped image will be displayed in landscape orientation. If you want to crop the portrait image in the captured position, use **Rotate image** ( 67) to change the position of the portrait image to landscape before cropping it, and then return the image to the captured position.

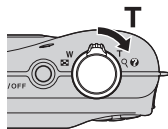

- 2 Refine copy composition.

Rotate the zoom control to **T** () or **W** () to adjust the zoom ratio.

Press the multi selector , ,  or  to scroll the image until only the portion you want to copy is visible in the monitor.



- 3 Press the **MENU** button.

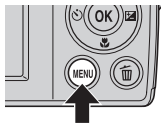



- 4 Use the multi selector to select **Yes** and press the **OK** button.

A cropped copy is created.

To exit without saving the copy, choose **No** and press the **OK** button.



### **About the Size of the Original Image**

As the area to be saved is reduced, the image size (pixels) of the cropped copy is also reduced. When the image is cropped and the size of the cropped copy is 320 × 240 or 160 × 120, the image is displayed with a black border on the playback screen, and the small picture icon  or  is displayed on the left of the playback screen.





### **More Information**

See, “File and Folder Names” ( 118) for more information.

## Recording Movies

Movies with sound can be recorded.

The maximum size for a single movie is 2 GB, and the maximum movie length for a single movie is 29 minutes, even when there is sufficient free space on the memory card (📖 77).

- 1 Press the  button and then press the multi selector  or  to select , and press the  button.

The camera enters movie mode.

The maximum length of the movie that can be recorded is displayed in the monitor (📖 77).

The current movie options setting is displayed. The default setting is  **VGA (640×480)** (📖 77).



Movie options

- 2 Press the shutter-release button all the way down to start recording a movie.

The camera focuses when the shutter-release button is pressed halfway, and the focus remains locked while the shutter-release button is pressed halfway. Focus is locked while recording.

The approximate remaining movie length is displayed during recording. If recording time runs out, recording stops automatically.



- 3 Press the shutter-release button to end recording.



### While the Camera Is Saving Movies

After movie recording stops, the camera saves the movie and then switches to the shooting screen when saving is complete. **Do not open the battery-chamber/memory card slot cover before the camera switches to the shooting screen.** Removing the memory card or the batteries while a movie is being saved may result in loss of the movie data or damage to the camera or the memory card.

## Recording Movies

- The optical zoom magnification ratio cannot be changed once recording starts.
- Use the zoom control to operate digital zoom while recording movies. The zoom range is between the optical zoom magnification ratio before recording a movie and up to 2×.
- There may be some degradation in image quality when digital zoom is used. When recording ends, digital zoom turns off.
- Operation sounds from the time of recording (the zoom control being rotated, and autofocus being used, etc.) may be heard when playing back movies.
- Smear (📖 115) visible in the monitor when recording movies is visible in the saved movie file. Avoiding bright objects such as the sun, reflections of the sun, and electric lights is recommended to avoid smear effects.

## Options Available When Recording Movies

- The current exposure compensation setting is applied when recording movies. When macro mode is enabled, movies of subjects closer to the camera can be recorded.
- The self-timer (📖 28) can be used. The camera focuses when the shutter-release button is pressed, then begins recording after ten seconds.
- Flash will not fire when picture is taken.
- Press the **MENU** button before starting movie recording to display the 🎬 (movie) menu and set the **Movie options** (Movie type) (📖 77).

## Changing Movie Recording Settings

**Movie options** setting can be changed from the movie menu.

### Displaying the Movie Menu

Press the 📷 button in shooting mode to enter 🎬 (movie) mode (📖 75).

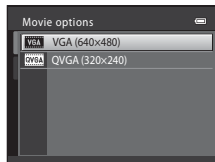
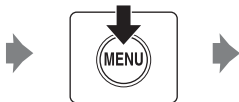

Press the **MENU** button to display the movie menu.



- Use the multi selector to choose and apply settings (📖 9).
- To exit the menu, press the **MENU** button.



## Movie Options

The movie menu offers the options shown below. Higher resolutions mean greater image quality and larger movie file sizes.

Option	Resolution and Frame Rate
 VGA (640×480) (default setting)	Resolution: 640 × 480
 QVGA (320×240)	Resolution: 320 × 240

- The frame rate is approximately 30 frames per second in any options.

### Movie Options and Maximum Movie Length

Option	Internal memory (Approx. 22 MB)	Memory card (4 GB)*
 VGA (640×480) (default setting)	12 s	40 min
 QVGA (320×240)	40 s	2 h 10 min

All figures are approximate. Maximum movie length or frames varies with make of memory card.

\* The maximum size for a single movie is 2 GB, and the maximum movie length for a single movie is 29 minutes, even when there is sufficient free space on the memory card. The maximum recording time that is displayed is the maximum recording time for one movie.

### More Information

See, “File and Folder Names” ( 118) for more information.

# Movie Playback

In full-frame playback mode (📖 24), movies can be identified by the Movie options icon (📖 77). To play a movie, display it in full-frame playback mode and press the **OK** button.

Use the zoom control **T/W** to adjust playback volume. Playback controls appear at the top of the monitor. Press the multi selector **◀** or **▶** to choose a control and press the **OK** button to perform the following operations.

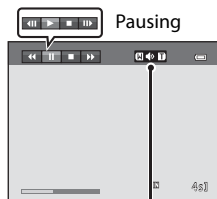

During playback      Volume indicator

Function	Icon	Description	
Rewind	⏮	Rewind movie. Playback resumes when the <b>OK</b> button is released.	
Advance	⏭	Advance movie. Playback resumes when the <b>OK</b> button is released.	
Pause	⏸	⏮	Rewind movie by one frame. Rewind continues while the <b>OK</b> button is pressed.
		⏭	Advance movie by one frame. Advance continues while the <b>OK</b> button is pressed.
		▶	Resume playback
End	⏹	End playback and return to full-frame playback.	

## ✓ Playing Back Movies

Only movies recorded with COOLPIX L23 can be played back.

## Deleting Movies

Select a movie and press the **🗑** button in full-frame playback mode (📖 24) or thumbnail playback mode (📖 57).

See “Deleting Unwanted Images” (📖 25) for more information.

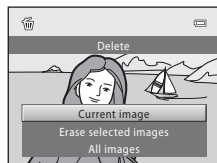

## Connecting to a TV

Connect the camera to a television using an optional audio/video cable (📖 116) to play back images on a television.

### 1 Turn off the camera.

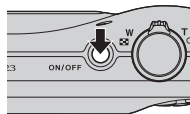

### 2 Connect the camera to the TV.

Connect the yellow plug of the audio/video cable to the video-in jack on the TV, and the white plug to the audio-in jack.

Be sure that the connectors are oriented correctly. Do not use force when connecting the cable. When disconnecting the audio/video cable, do not pull the connector at an angle.

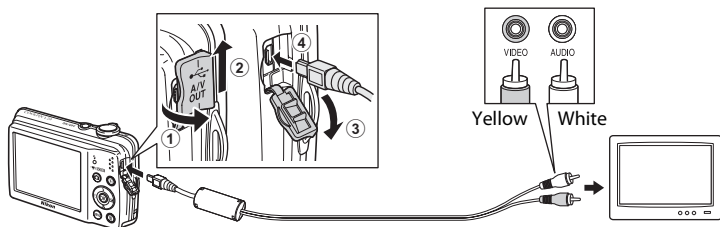

### 3 Tune the television to the video channel.

See the documentation provided with your television for details.

### 4 Hold down the button to turn on the camera.

The camera enters playback mode, and the images captured will be displayed on the television.

While connected to the TV, the camera monitor will remain off.



### If the Images Are Not Displayed on the Television

Be sure that the camera's video mode setting in the **Set up** menu (📖 91) → **Video mode** (📖 106) conforms to the standard used by your television.

## Connecting to a Computer

Use the supplied USB cable to connect the camera to a computer and copy (transfer) images to the computer.

### Before Connecting the Camera

#### Install the Software

Use the supplied ViewNX 2 CD and install the following software on the computer. For more information on installing the software, refer to the *Quick Start Guide*.

- ViewNX 2: Use the image transfer feature “Nikon Transfer 2” to save images that were captured with the camera on the computer. Saved images can be viewed and printed. Image and movie editing features are also supported.
- Panorama Maker 5: This software can join a series of images to create a single panorama image.

#### Compatible Operating Systems

##### Windows

Windows 7 Home Basic/Home Premium/Professional/Enterprise/Ultimate, Windows Vista Home Basic/Home Premium/Business/Enterprise/Ultimate (Service Pack 2), or Windows XP Home Edition/Professional (Service Pack 3)

##### Macintosh

Mac OS X (version 10.4.11, 10.5.8, 10.6.5)

Refer to the Nikon website for the latest information on operating system compatibility.

#### Notes on Power Source

- When connecting the camera to a computer, use batteries with a sufficient amount of charge remaining to prevent the camera from turning off unexpectedly.
- To power the camera continuously for extended periods, use an AC Adapter EH-65A (available separately) (☐ 116). Do not, under any circumstances, use another make or model of AC adapter. Failure to observe this precaution could result in overheating or in damage to the camera.

## Transferring Images from a Camera to a Computer

- 1 Start the computer to which ViewNX 2 was installed.
- 2 Be sure that the camera is off.
- 3 Connect the camera to the computer using the supplied USB cable.

Be sure that connectors are properly oriented. Do not attempt to insert connectors at an angle, and do not use force when connecting or disconnecting the USB cable.

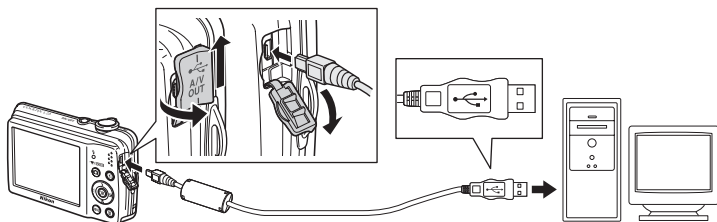

- 4 Turn on the camera.

The power-on lamp will light. The camera monitor will remain off.

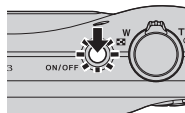

### ✓ Connecting the USB Cable

The connection may not be recognized if the camera is connected to the computer via a USB hub.

## 5 Start the ViewNX 2 image transfer feature “Nikon Transfer 2” installed on the computer.

### • Windows 7

When the **Devices and Printers** ► **L23** screen is displayed, click **Change program** under **Import pictures and videos**. Select **Import File using Nikon Transfer 2** in the **Change program** dialog and click **OK**.

Double-click **Import File** on the **Devices and Printers** ► **L23** screen.

### • Windows Vista

When the **AutoPlay** dialog is displayed, click **Import File using Nikon Transfer 2**.

### • Windows XP

When the action selection dialog is displayed, select **Nikon Transfer 2 Import File**, and click **OK**.

### • Mac OS X

Nikon Transfer 2 will start automatically when the camera is connected to the computer if **Yes** was selected in the **Auto-Launch setting** dialog when ViewNX 2 was first installed.

- See “Starting Nikon Transfer 2 Manually” (📖 84) for more information.

- If there are a large number of images on the memory card, it may take some time for Nikon Transfer 2 to start.

## 6 Confirm that the source device is displayed in the transfer options **Source** panel and click **Start Transfer**.

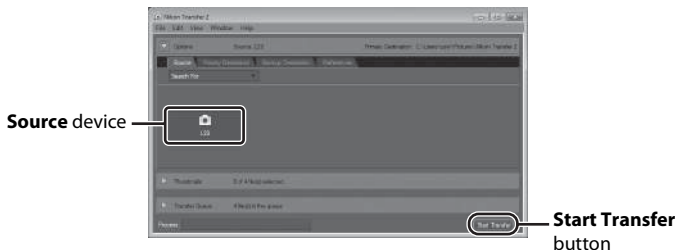

Any images that have not been transferred to the computer will be transferred (default setting of ViewNX 2).

When transfer is complete, the ViewNX 2 screen is displayed (ViewNX 2 default setting) and transferred images are displayed.

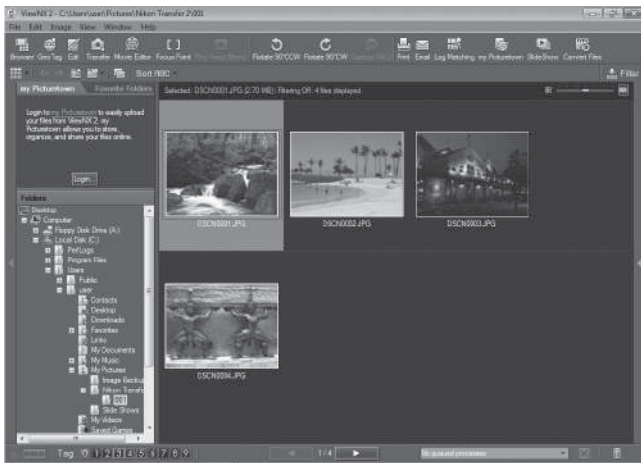

For more information on using ViewNX 2, refer to the ViewNX 2 help information (84).

## Disconnecting the Camera

Do not turn off the camera or disconnect the camera from the computer during transfer.

When transfer is complete, turn off the camera and disconnect the USB cable.

### **Transferring Images Using a Computer's Card Slot or a Commercially-available Card Reader**

When the memory card is inserted into a computer's card slot or into a commercially-available card reader, the images can be transferred using "Nikon Transfer 2", the image transfer feature of ViewNX 2.

- Make sure that the memory card being used is supported by the card reader or other card reading device.
- To transfer images, insert the memory card into the card reader or card slot and follow the procedure from step 5 (📖 82).
- To transfer images saved in the camera's internal memory, the images must first be copied to a memory card using the camera (📖 68).

### **Starting ViewNX 2 Manually**

#### **Windows**

Choose **Start** menu > **All Programs** > **ViewNX 2** > **ViewNX 2**.

Double-clicking the **ViewNX 2** shortcut icon on the desktop will also start ViewNX 2.

#### **Mac OS X**

Open the **Applications** folder, open the **Nikon Software** > **ViewNX 2** folders in that order, and then double-click the **ViewNX 2** icon. Clicking the **ViewNX 2** icon on the Dock will also start ViewNX 2.

### **Starting Nikon Transfer 2 Manually**

To start Nikon Transfer 2, first start ViewNX 2, and then click the **Transfer** icon at the top of the screen or select **Launch Transfer** from the **File** menu.

### **For More Information on Using ViewNX 2 and Nikon Transfer 2**

For more information on ViewNX 2 or Nikon Transfer 2, start ViewNX 2 or Nikon Transfer 2 and select **ViewNX 2 Help** from the **Help** menu.

### **Panorama Creation with Panorama Maker 5**

- Use a series of images captured in **Panorama assist** scene mode (📖 41) to create a single panorama photo with Panorama Maker 5.
- Panorama Maker 5 can be installed on a computer using the supplied ViewNX 2 CD.
- After installation is complete, follow the procedure described below to start Panorama Maker 5.

#### **Windows**

Choose **Start** menu > **All Programs** > **ArcSoft Panorama Maker 5** > **Panorama Maker 5**.

#### **Mac OS X**

Open **Applications** and double-click the **Panorama Maker 5** icon.

- For more information on using Panorama Maker 5, refer to the on-screen instructions and help information contained in Panorama Maker 5.

### **Image File Names and Folder Names**

See "File and Folder Names" (📖 118) for more information.

## Connecting to a Printer

Users of PictBridge-compatible (📖 131) printers can connect the camera directly to the printer and print images without using a computer. Follow the procedures below to print images.

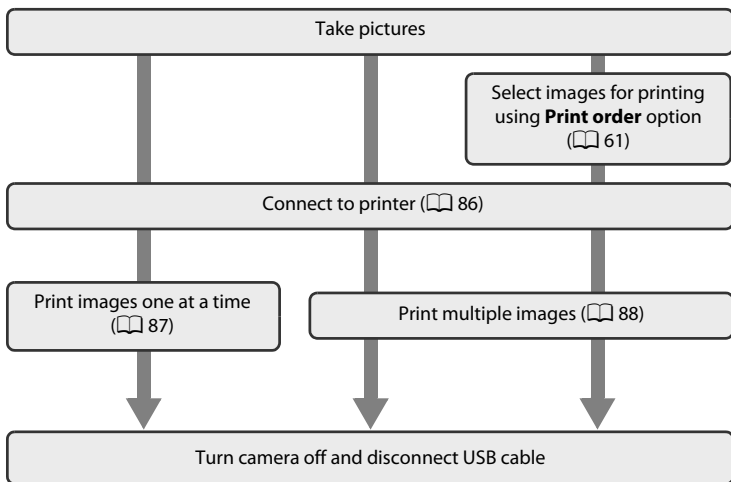

### ✔ Note on Power Source

When connecting the camera to a printer, use a fully charged batteries to prevent the camera from turning off unexpectedly.

To power the camera continuously for extended periods, use an AC Adapter EH-65A (available separately) (📖 116). Do not, under any circumstances, use another make or model of AC adapter. Failure to observe this precaution could result in overheating or in damage to the camera.

### 🔍 Printing Images

In addition to printing images transferred to a computer from your personal printer and printing over a direct camera-to-printer connection, the following options are also available for printing images:

- Insert a memory card into a DPOF-compatible printer's card slot.
- Take a memory card to a digital photo lab.

For printing using these methods, you can specify the images and the number of prints each using **Print order** in the playback menu (📖 61).

## Connecting the Camera and Printer

- 1 Turn off the camera.

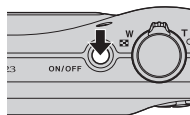

- 2 Turn on the printer.

Check printer settings.

- 3 Connect the camera to the printer using the supplied USB cable.

Be sure that connectors are properly oriented. Do not attempt to insert connectors at an angle, and do not use force when connecting or disconnecting the USB cable.

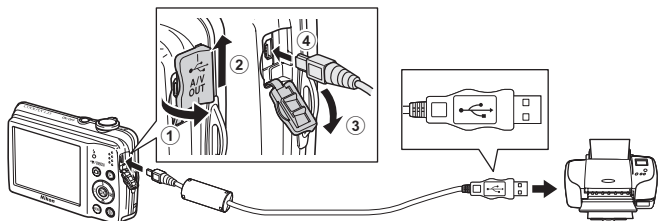

- 4 Turn on the camera.

When connected correctly, the **PictBridge** startup screen (1) is displayed in the camera monitor, then the **Print selection** screen (2) is displayed.

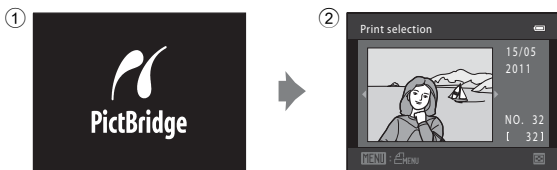
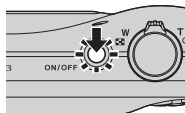

## Printing Images One at a Time

After connecting the camera to the printer correctly (📖 86), print images by following the procedure below.

- 1 Use the multi selector to choose the desired image and press the **OK** button.

Rotate the zoom control to **W** (📐) to display 12 thumbnails, and to **T** (📺) to switch back to full-frame playback.

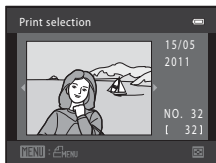

- 2 Choose **Copies** and press the **OK** button.

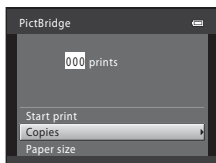

- 3 Choose the number of copies (up to nine) and press the **OK** button.

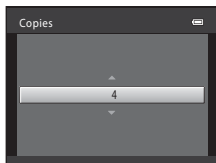

- 4 Choose **Paper size** and press the **OK** button.

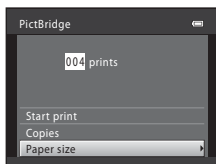

- 5 Choose the desired Paper size and press the **OK** button.

To specify paper size using printer settings, choose **Default** in the paper size menu.

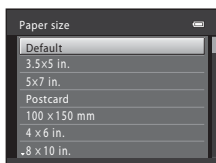

- 6** Choose **Start print** and press the **OK** button.

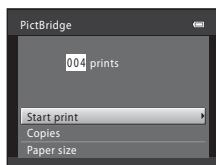

- 7** Printing starts.

Monitor display returns to that shown in step 1 when printing is complete.

To cancel before all copies have been printed, press the **OK** button.

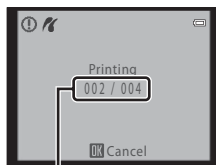

Current print/ total number of prints

## Printing Multiple Images

After connecting the camera to the printer correctly (86), print images by following the procedure below.

- 1** When the **Print selection** screen is displayed, press the **MENU** button.

The **Print menu** is displayed.

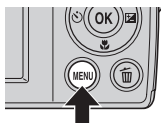

- 2** Use the multi selector to choose **Paper size** and press the **OK** button.

Press the **MENU** button to exit the print menu.

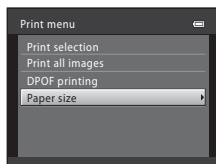

- 3** Choose the desired Paper size and press the **OK** button.

To specify paper size using printer settings, choose **Default** in the paper size menu.

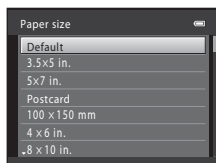

#### 4 Choose **Print selection**, **Print all images** or **DPOF printing** and press the **OK** button.

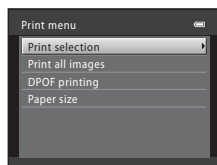

##### Print selection

Select the images (up to 99) and the number of copies (up to nine) of each image.

Press the multi selector ◀ or ▶ to select images, and press ▲ or ▼ to set the number of copies for each.

Images selected for printing can be identified by the check mark ✓ and the numeral indicating the number of copies to be printed. Images for which no copies have been specified will not be printed.

Rotate the zoom control to **W** (🗪) to display 12 thumbnails, and **T** (📷) to switch back to full-frame playback.

Press the **OK** button when setting is complete.



When the menu shown on the right is displayed, select **Start print** and press the **OK** button to start printing. Choose **Cancel** and press the **OK** button to return to the print menu.

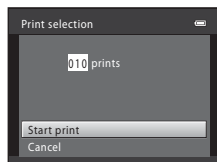

##### Print all images

All images saved in the internal memory, or on the memory card, are printed one at a time.

When the menu shown on the right is displayed, select **Start print** and press the **OK** button to start printing. Choose **Cancel** and press the **OK** button to return to the print menu.

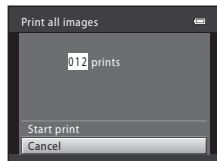

## DPOF printing

Print images for which a print order was created in **Print order** (61).

- When the menu shown on the right is displayed, select **Start print** and press the **OK** button to start printing. Choose **Cancel** and press the **OK** button to return to the print menu.
- To view the current print order, choose **View images** and press the **OK** button. To print images, press the **OK** button again.

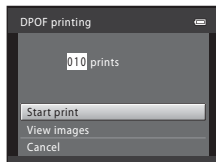

## 5 Printing starts.

Monitor display returns to the print menu (step 2) when printing is complete.

To cancel before all copies have been printed, press the **OK** button.

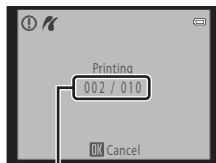

















Current print/ total number of prints

## Paper Size

The camera supports the following paper sizes: **Default** (the default paper size for the current printer), **3.5x5 in.**, **5x7 in.**, **100x150 mm**, **4x6 in.**, **8x10 in.**, **Letter**, **A3**, and **A4**. Only sizes supported by the current printer will be displayed.

## Setup Menu

The setup menu contains the following settings.

<b>Welcome screen</b>	 93
Specify the welcome screen displayed when the camera is turned on.	
<b>Time zone and date</b>	 94
Set camera clock and choose home and destination time zones.	
<b>Monitor settings</b>	 98
Adjust photo information display and monitor brightness settings.	
<b>Print date</b>	 100
Imprint the shooting date and time on images.	
<b>Electronic VR</b>	 101
Specify the electronic vibration reduction setting for taking still images.	
<b>Motion detection</b>	 102
Set whether or not the camera automatically increases the shutter speed to reduce blurring when motion is detected while taking still images.	
<b>AF assist</b>	 103
Enable or disable AF-assist illumination.	
<b>Sound settings</b>	 103
Adjust sound settings.	
<b>Auto off</b>	 104
Set the amount of time that passes before the monitor turns off to save power.	
<b>Format memory/Format card</b>	 105
Format internal memory or memory card.	
<b>Language</b>	 106
Choose the language used for camera monitor display.	
<b>Video mode</b>	 106
Adjust settings for connection to a television.	
<b>Blink warning</b>	 107
Set whether or not to detect human subjects with eyes closed when taking pictures using face detection.	
<b>Reset all</b>	 109
Restore camera settings to their default values.	
<b>Battery type</b>	 111
Select the type of batteries used.	
<b>Firmware version</b>	 111
Display camera firmware version.	

## Displaying the Setup Menu

### 1 Press the **MENU** button.

The menu is displayed.

When using easy auto mode, scene mode, or movie mode, press ◀ on the multi selector (📖 9) to display the tab.

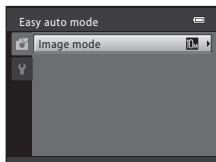
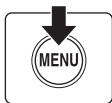

### 2 Press the multi selector ◀ to enter the menu.

You can now select a tab.

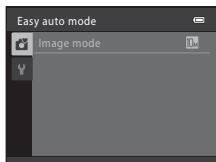

### 3 Press ▲ or ▼ to select the 📖 tab.

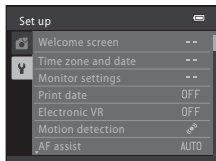

### 4 Press ▶ or the **OK** button.

You can now select an item from the setup menu.

Use the multi selector to choose and apply settings (📖 9).

To exit the setup menu, press the **MENU** button or press ◀ and select another tab.

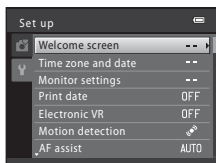

## Welcome Screen

MENU button →  (setup menu) (📖 92) → Welcome screen

Specify the welcome screen displayed when the camera is turned on.

### None (default setting)

The welcome screen is not displayed when the camera is turned on; the shooting mode or playback mode screen is displayed.

### COOLPIX

The welcome screen is displayed when the camera is turned on, then the shooting mode or playback mode screen is displayed.



### Select an image

An image captured with this camera is used as the welcome screen.

When the image selection screen is displayed (📖 66), select the desired image and press the  button to register the image as the welcome screen.

- As the selected image is saved in the camera, the image will appear in the welcome screen even if the original image is deleted.
- Images captured at an **Image mode** setting (📖 49) of  **3584x2016**, and images created by using small picture (📖 72) or crop (📖 73) that are 320 x 240 or smaller, cannot be used.







## Time Zone and Date

MENU button →  (setup menu) ( 92) → Time zone and date

Set the camera clock.

### Date and time

Set camera clock to current date and time.  
Use the multi selector to set the date and time.

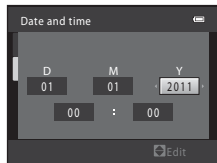

- Choose an item: Press  or  (to change between **D**, **M**, **Y**, **Hour**, and **Minute**).
- Edit the highlighted item: Press  or .
- Apply the setting: Choose **Minute** and press the  button or .



### Date format

The available date formats are **Year/Month/Day**, **Month/Day/Year**, and **Day/Month/Year**.

### Time zone

Set the home () time zone (district) or daylight saving time. When the destination () time zone is selected, the time difference ( 97) is automatically calculated and the date and time in the selected region are recorded. Useful when travelling.

## Setting Travel Destination Time Zone

- 1** Use the multi selector to choose **Time zone** and press the **OK** button.

The **Time zone** menu is displayed.

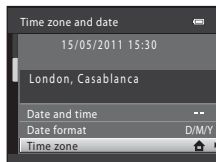

- 2** Choose **Travel destination** and press the **OK** button.

The date and time displayed on the monitor changes according to the region currently selected.

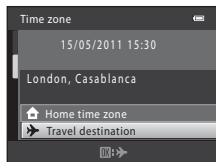

- 3** Press **▶**.

The time zone selection screen is displayed.

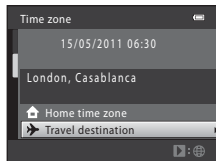

- 4** Press **◀** or **▶** to select the travel destination region (time zone).

When using the camera in an area where daylight saving time is in effect, press **▲** to adjust the camera's time for daylight saving time.  will be displayed in the top of the monitor and the time will advance one hour. To turn off the daylight saving time setting, press **▼**.

Press the **OK** button to enter the travel destination.

While the travel destination time zone is selected, the  icon will be displayed in the monitor when the camera is in shooting mode.

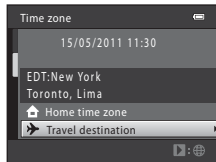
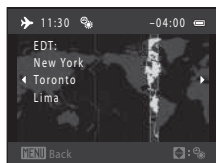

### **The Clock Battery**

The camera's clock is powered by a clock battery that is independent of the batteries that power the camera. The clock battery charges when the main batteries are installed or an AC adapter is connected, and can provide several days of backup power after about ten hours of charging.

### **🏠 (Home Time Zone)**

- To switch to the home time zone, choose **🏠 Home time zone** in step 2 and press the **OK** button.
- To change the home time zone, choose **🏠 Home time zone** in step 2 and perform steps 3 and 4, to set the home time zone.

### **Daylight Saving Time**

When the daylight saving time begins or ends, turn the daylight saving time option on or off using the time zone selection screen in Step 4.

### **Imprinting the Date on Images**

After setting the date and time, set the **Print date** setting in the setup menu (📖 100). Once **Print date** is set, the shooting date and time can be imprinted on the image data when taking pictures.



 **Time Zones**

The camera supports the time zones listed below.

For time zones not listed below, set the camera's clock manually to local time using **Date and time** in the setup menu.

UTC +/-	Time zone	UTC +/-	Time zone
-11	Midway, Samoa	+1	Madrid, Paris, Berlin
-10	Hawaii, Tahiti	+2	Athens, Helsinki, Ankara
-9	Alaska, Anchorage	+3	Moscow, Nairobi, Riyadh, Kuwait, Manama
-8	PST (PDT): Los Angeles, Seattle, Vancouver	+4	Abu Dhabi, Dubai
-7	MST (MDT): Denver, Phoenix	+5	Islamabad, Karachi
-6	CST (CDT): Chicago, Houston, Mexico City	+5.5	New Delhi
-5	EST (EDT): New York, Toronto, Lima	+6	Colombo, Dhaka
-4.5	Caracas	+7	Bangkok, Jakarta
-4	Manaus	+8	Beijing, Hong Kong, Singapore
-3	Buenos Aires, Sao Paulo	+9	Tokyo, Seoul
-2	Fernando de Noronha	+10	Sydney, Guam
-1	Azores	+11	New Caledonia
±0	London, Casablanca	+12	Auckland, Fiji

## Monitor Settings

MENU button →  (setup menu)  92 → Monitor settings

The following settings are available.

### Photo info

Choose information displayed in monitor during shooting and playback mode.

→  99







### Brightness

Choose from five settings for monitor brightness. The default setting is **3**.

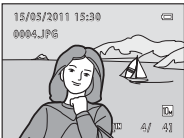
## Photo Info

Select whether or not photo info is displayed.

See “The Monitor” (📖 6, 7) for information on indicators in the monitor.

	Shooting mode	Playback mode
Show info		
Auto info (default setting)	The same information as in <b>Show info</b> is displayed. If no operations are performed after a few seconds, the display will be the same as <b>Hide info</b> . The information is displayed again when an operation is performed.	
Hide info		
Framing grid+auto info	 <p>In the following shooting modes, a framing grid is displayed to help frame pictures, in addition to the information displayed in <b>Auto info</b>.</p> <ul style="list-style-type: none"> <li>•  (Easy auto)</li> <li>•  (Auto)</li> </ul> <p>In other shooting modes, the same information as in <b>Auto info</b> is displayed.</p>	 <p>The same information as in <b>Auto info</b> is displayed.</p>

## Print Date

MENU button →  (setup menu) ( 92) → Print date

The shooting date and time can be imprinted on images at the time of shooting. This shooting date and time will be imprinted on images when printing, even if the printer does not support date printing ( 62).



### Date

Date is imprinted on images.

### Date and time



Date and time are imprinted on images.

### OFF Off (default setting)

Date and time are not imprinted on images.

At settings other than **Off**, the icon for the current setting is displayed in the monitor ( 6).

## Print Date

- Imprinted dates form a permanent part of image data and cannot be deleted. The date and time cannot be imprinted on images after they have been captured.
- Date imprint is disabled in the following situations.
  - When using the **Sports**, **Museum**, or **Panorama assist** scene modes
  - When shooting movies
- Dates imprinted at an **Image mode** setting ( 49) of **VGA 640×480** may be difficult to read. Choose **PC 1024×768** or larger when using print date.
- The date is recorded using the format selected in the setup menu's **Time zone and date** item ( 14, 94).

## Print Date and Print Order

When images are printed from DPOF-compatible printers that can print date and shooting information, you can use **Print order** ( 61) and print the shooting date and shooting information on the images. In such a case, it is unnecessary to imprint date and time on images beforehand using **Print date**.

## Electronic VR

MENU button →  (setup menu) (📖 92) → Electronic VR

Choose whether to use electronic VR (vibration reduction) when taking still pictures.

### Auto

In the following conditions, electronic VR is applied and the effects of camera shake are reduced when shooting still images.

- The flash is turned off or set to slow sync mode
- The shutter speed is slow
- The **Continuous** setting is set to **Single**
- When the subject is dark

### OFF Off (default setting)

Electronic VR is disabled.

When **Auto** is selected,  appears on the monitor (📖 6), and electronic VR is applied depending on shooting conditions.

## Notes on Electronic Vibration Reduction

- Electronic VR is disabled while the flash is used, except when using slow sync mode. Note that Electronic VR is disabled even when flash mode is slow sync with red-eye reduction (📖 34, 35).
- If the exposure period exceeds a certain period of time, electronic VR will not function.
- Electronic VR cannot be used if **Blink proof** (📖 45) in smart portrait mode is set to **On**.
- Electronic VR cannot be used when using the following scene modes.
  - Sports (📖 34)
  - Night portrait (📖 34)
  - Dusk/dawn (📖 36)
  - Night landscape (📖 36)
  - Museum (📖 38)
  - Fireworks show (📖 39)
  - Backlighting (📖 39)
- The effectiveness of electronic VR decreases as camera shake increases.
- The images captured may become somewhat grainy.

## Motion Detection

MENU button →  (setup menu) (📖 92) → Motion detection

Set whether or not the camera automatically increases the shutter speed to reduce blurring when motion is detected while taking still pictures.

### Auto (default setting)

In order to reduce the effects of camera shake or subject movement, ISO sensitivity and shutter speed are increased when the camera detects camera shake or subject movement.

However, motion detection does not function in the following situations.

- When the flash mode is set to **Fill flash**
- When **Continuous** (📖 53) is set to **Multi-shot 16**
- When scene mode is set to **Sports** (📖 34), **Night portrait** (📖 34), **Dusk/dawn** (📖 36), **Night landscape** (📖 36), **Museum** (📖 38), **Fireworks show** (📖 39), or **Backlighting** (📖 39)

### OFF Off

Motion detection is disabled.

The icon for the current setting is displayed in the monitor when the camera is in shooting mode (📖 19). When the camera detects shaking and increases shutter speed, the motion detection indicator turns green. No icon is displayed when **Off** is selected.

### Notes on Motion Detection

- Blurring caused by camera shake or subject movement may not be eliminated in some situations.
- Motion detection may not function if camera shake or subject movement is excessive, or if there is insufficient lighting.
- The images captured may become somewhat grainy.

## AF Assist

MENU button →  (setup menu) (📖 92) → AF assist

Enable or disable AF-assist illuminator, which assists autofocus operation when the subject is dimly lit.

### Auto (default setting)

AF-assist illumination will be used to assist the focus operation when the subject is poorly lit. The illuminator has a range of about 1.9 m (6 ft. 3 in.) at the maximum wide-angle position and 1.1 m (3 ft. 7 in.) at the maximum telephoto position. However, the AF-assist illumination will not turn on in some scene modes even if **Auto** is selected.

### Off

AF-assist illuminator is disabled. The camera may be unable to focus if lighting is poor.

## Sound Settings

MENU button →  (setup menu) (📖 92) → Sound settings

Adjust the following sound settings.

### Button sound

Choose button sound from **On** (default setting) or **Off**. When **On** is selected, a beep will sound once when operations are completed successfully, two times when the focus has been locked, and three times when an error is detected, and welcome sound is played when the camera is turned on.

### Shutter sound

Choose shutter sound from **On** (default setting) or **Off**.  
Even when set to **On**, the shutter sound is not heard in the following situations.

- When using **Continuous**, **BSS**, or **Multi-shot 16**
- When using **Sports** or **Museum**
- When shooting movies

## Auto Off

MENU button →  (setup menu) (📖 92) → Auto off

If no operations are performed for a specified amount of time, the monitor turns off and the camera enters standby mode (📖 13).

Use this option to set the amount of time that passes before the camera enters standby mode.



### Auto off

Choose from **30 s** (default setting), **1 min**, **5 min**, and **30 min**.

### Sleep mode

If **On** (default setting) is selected, the camera will enter standby mode when there is no change in the brightness of the subject, even before the time selected in the auto off menu has elapsed. The camera will enter sleep mode after 30 seconds when **Auto off** is set to **1 min** or less, or after 1 minute when **Auto off** is set to **5 min** or more.

## When the Monitor Has Turned Off to Save Power



- When the camera is in standby mode, the power-on lamp blinks.
- If no operations are performed for another three minutes, the camera will turn off automatically.
- When the power-on lamp is blinking, pressing the following buttons will turn the monitor back on.  
→ Power switch, shutter-release button,  button, or  button

## Auto Off

The time allowed to elapse before the camera enters standby mode is fixed in the following situations:

- While menus are displayed: Auto off is extended to three minutes if it is set to **30 s** or **1 min**.
- During slide show playback: Up to 30 minutes

## Format Memory/Format Card

MENU button →  (setup menu) ( 92) → Format memory/Format card

Use this option to format the internal memory or a memory card.

**Formatting the internal memory or memory cards permanently deletes all data. Deleted images cannot be restored.** Be sure to transfer important images to a computer before formatting.

### Formatting Internal Memory

To format the internal memory, remove the memory card from the camera.

The **Format memory** option appears in the setup menu.

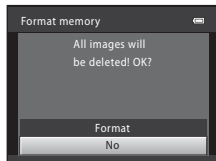

### Formatting a Memory Card

When the memory card is inserted in the camera, the **Format card** option appears in the setup menu.

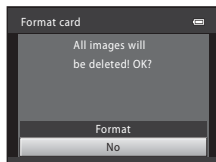

### Formatting Internal Memory and Memory Cards

- Do not turn the camera off or open the battery-chamber/memory card slot cover during formatting.
- The first time you insert the memory cards used in other devices into this camera, be sure to format them using this camera.

## Language

MENU button →  (setup menu) (📖 92) → Language

Select the language used for camera monitor display.

Čeština	Czech
Dansk	Danish
Deutsch	German
English	(default setting)
Español	Spanish
Ελληνικά	Greek
Français	French
Indonesia	Indonesian
Italiano	Italian
Magyar	Hungarian
Nederlands	Dutch
Norsk	Norwegian
Polski	Polish

Português	Portuguese
Русский	Russian
Română	Romanian
Suomi	Finnish
Svenska	Swedish
Türkçe	Turkish
Українська	Ukrainian
عربي	Arabic
简体中文	Simplified Chinese
繁體中文	Traditional Chinese
日本語	Japanese
한글	Korean
ภาษาไทย	Thai

## Video Mode

MENU button →  (setup menu) (📖 92) → Video mode

Adjust settings for connection to a television. Choose from **NTSC** and **PAL**.

## Blink Warning

MENU button →  (setup menu) (📖 92) → Blink warning

Choose whether or not blinking eyes are detected when using face detection (📖 22) in the following shooting modes.

-  (easy auto) mode
- **Portrait** (📖 33) and **Night portrait** (📖 34) scene modes

### On

When the camera detects that one or more human subjects may have blinked in an image captured using face detection, the **Did someone blink?** screen will appear on the monitor.

The face of the human subject that may have closed his/her eyes is framed by a yellow border. In such a case, you can check the captured image and determine if you take the picture again. → “Operating the **Did someone blink?** Screen” (📖 108)

### Off (default setting)

Blink warning is disabled.

## Operating the Did someone blink? Screen

The following operations are available while the **Did someone blink?** screen is displayed.

If no operations are performed for a few seconds, the screen automatically returns to the shooting mode screen.



Function	Control	Description
Enlarge and display the face of the person who blinked	<b>T</b> (Q)	Rotate the zoom control to <b>T</b> (Q).
Switch to full-frame playback	<b>W</b> (checkered flag)	Rotate the zoom control to <b>W</b> (checkered flag).
Select the face to be displayed		If the camera detects more than one human subjects with their eyes closed, press ▲▼◀▶ during the enlarged display to switch over the face displayed.
Delete the captured image		Press the  button.
Switch to shooting mode		Press the  button or the shutter-release button.

## Reset All

MENU button →  (setup menu) (📖 92) → Reset all

When **Reset** is selected, the camera's settings will be restored to their default values.

## Pop-up Menu

Option	Default value
Flash mode (📖 26)	Auto
Self-timer (📖 28)	Off
Macro mode (📖 47)	Off
Exposure compensation (📖 29)	0.0

## Scene Mode

Option	Default value
Scene mode (📖 32)	Portrait
Hue adjustment in food mode (📖 38)	Center

## Movie Menu

Option	Default value
Movie options (📖 77)	 VGA (640×480)

## Shooting Menu

Option	Default value
Image mode (📖 49)	 3648×2736
White balance (📖 51)	Auto
Continuous (📖 53)	Single
Color options (📖 54)	Standard color

## Smart Portrait Menu

Option	Default value
Skin softening (📖 45)	On
Blink proof (📖 45)	Off

## Setup Menu

Option	Default value
Welcome screen (📖 93)	None
Photo info (📖 98)	Auto info
Brightness (📖 98)	3
Print date (📖 100)	Off
Electronic VR (📖 101)	Off
Motion detection (📖 102)	Auto
AF assist (📖 103)	Auto
Button sound (📖 103)	On
Shutter sound (📖 103)	On
Auto off (📖 104)	30 s
Sleep mode (📖 104)	On
Blink warning (📖 107)	Off

## Others

Option	Default value
Paper size (📖 87, 88)	Default

- Choosing **Reset all** also clears the current file number (📖 118) from the memory. Numbering will continue from the lowest number available. To reset file numbering to "0001", delete all images (📖 25) before selecting **Reset all**.
- The following settings in the menus will remain unaffected even if **Reset all** is performed.

Shooting menu:

Preset manual in the **White balance** menu (📖 52)

Setup menu:

Settings for image registered for **Welcome screen** (📖 93), **Time zone and date** (📖 94), **Language** (📖 106), **Video mode** (📖 106), and **Battery type** (📖 111)

## Battery Type

MENU button →  (setup menu) (📖 92) → Battery type

To ensure that the camera shows the correct battery level (📖 18), choose the type that matches the batteries currently in use.

Alkaline (default setting)	LR6/L40 (AA-size) Alkaline batteries
COOLPIX (Ni-MH)	Nikon EN-MH2 Ni-MH (nickel metal hydride) rechargeable batteries
Lithium	FR6/L91 (AA-size) lithium batteries

## Firmware Version

MENU button →  (setup menu) (📖 92) → Firmware version

View the current camera firmware version.

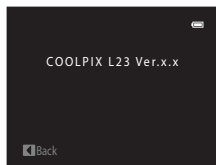

### Caring for the Camera

To ensure continued enjoyment of this Nikon product, observe the following precautions when using or storing the device:

#### **Keep dry**

The device will be damaged if immersed in water or subjected to high humidity.

#### **Do not drop**

The product may malfunction if subjected to strong shock or vibration.

#### **Handle the lens and all moving parts with care**

Do not apply force to the lens, lens cover, monitor, memory card slot or battery chamber. These parts are easily damaged. Applying force to the lens cover could result in camera malfunction or damage to the lens. Should the monitor break, care should be taken to avoid injury caused by broken glass and to prevent the liquid crystal from the display touching the skin or entering the eyes or mouth.

#### **Do not point the lens at strong light sources for extended periods**

Avoid pointing the lens at the sun or other strong light sources for extended periods when using or storing the camera. Intense light may cause deterioration of the image sensor, producing a white blur effect in photographs.

#### **Keep away from strong magnetic fields**

Do not use or store this device in the vicinity of equipment that generates strong electromagnetic radiation or magnetic fields. Strong static charges or the magnetic fields produced by equipment such as radio transmitters could interfere with the monitor, damage data stored on the memory card, or affect the product's internal circuitry.

#### **Avoid sudden changes in temperature**

Sudden changes in temperature, such as when entering or leaving a heated building on a cold day, can cause condensation to form inside the device. To prevent condensation, place the device in a carrying case or a plastic bag before exposing it to sudden changes in temperature.

#### **Turn the product off before removing or disconnecting the power source**

Do not remove the batteries while the product is on, or while images are being recorded or deleted. Forcibly cutting power in these circumstances could result in loss of data or in damage to product memory or internal circuitry.

 **The Battery**

- Check the battery level when taking the camera out, and replace the batteries if necessary (📖 18). If possible, carry spare batteries when taking pictures on important occasions.
- When recharging rechargeable batteries, do not recharge batteries that contain a different amount of charge, or batteries of different model numbers.
- When charging EN-MH2 batteries using Battery Charger MH-72, charge two batteries at a time. When charging EN-MH2 batteries using Battery Charger MH-73, charge two or four batteries at a time. To charge EN-MH2 batteries, use only Battery Charger MH-72 or MH-73. Do not use these battery chargers to charge any other type of battery.
- Do not use any battery charger other than the MH-70/71 to recharge EN-MH1 batteries. Do not use the MH-70/71 to charge any batteries other than EN-MH1 batteries. Set the Battery type setting (📖 111) to **COOLPIX (Ni-MH)**.
- Battery capacity tends to decrease on cold days. Be sure that the batteries are fresh before heading outside to take pictures in cold weather. Keep spare batteries in a warm place and exchange as necessary. Once warmed, a cold battery may recover some of its charge.
- Dirt on the battery terminals can prevent the camera from functioning.
- Used batteries are a valuable resource. Please recycle used batteries in accordance with local regulations.

## Cleaning

<b>Lens</b>	Avoid touching glass parts with your fingers. Remove dust or lint with a blower (typically a small device with a rubber bulb attached to one end that is pumped to produce a stream of air out the other end). To remove fingerprints or other stains that cannot be removed with a blower, wipe the lens with a soft cloth, using a spiral motion that starts at the center of the lens and working toward the edges. If this fails, clean the lens using a cloth lightly dampened with commercial lens cleaner.
<b>Monitor</b>	Remove dust or lint with a blower. To remove fingerprints and other stains, clean the monitor with a soft, dry cloth, being careful not to apply pressure.
<b>Body</b>	Use a blower to remove dust, dirt or sand, then wipe gently with a soft, dry cloth. After using the camera at the beach or seaside, wipe off any sand or salt with a dry cloth lightly dampened with fresh water, then dry thoroughly. Note that foreign matter inside the camera could cause damage not covered by the warranty.

Do not use alcohol, thinner, or other volatile chemicals.

## Storage

Turn the camera off when not in use. Check that the power-on lamp is off before putting the camera away. Remove the batteries if the camera will not be used for an extended period. Do not store the camera with naphtha or camphor moth balls, or in any of the following locations:

- Next to equipment that produces strong electromagnetic fields, such as televisions or radios
- Exposed to temperatures below  $-10^{\circ}\text{C}$  ( $14^{\circ}\text{F}$ ) or above  $50^{\circ}\text{C}$  ( $122^{\circ}\text{F}$ )
- Poorly ventilated or subject to humidities of over 60%

To prevent mold or mildew, take the camera out of storage at least once a month. Turn the camera on and release the shutter a few times before putting the camera away again.

### Notes on the Monitor

- The monitor may contain a few pixels that are always lit or that do not light. This is a characteristic common to all TFT LCD displays, and does not indicate a malfunction. Images saved using the product will not be affected.
- When framing bright subjects, vertical comet-like streaks that whiten toward either end may appear in the display. This phenomenon, known as “smear”, does not indicate a malfunction. In shooting modes other than movie mode, smear has no effect on the images that are saved.
- Images in the monitor may be difficult to see under bright lighting.
- The monitor is lit by an LED backlight. Should the monitor begin to dim or flicker, contact your Nikon-authorized service representative.

### Note on Smear

White or colored streaks may be visible when bright subjects are framed in the monitor. This phenomenon, known as “smear,” occurs when extremely bright light strikes the image sensor; it is characteristic of image sensors and does not indicate a malfunction. Smear may also take the form of partial discoloration in the monitor during shooting. It does not appear in images saved with the camera except in the cases of movies and of images saved with **Multi-shot 16** selected for **Continuous**. When shooting in these modes, we recommend that you avoid bright subjects such as the sun, reflected sunlight, and electric lights.

## Optional Accessories

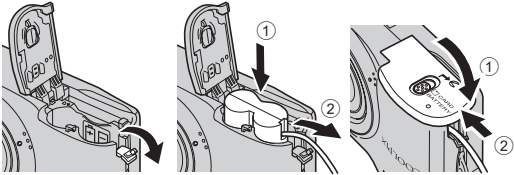
<p><b>Rechargeable battery</b></p>	<p>Rechargeable Ni-MH batteries EN-MH2-B2 (set of two EN-MH2 batteries)<sup>1</sup>                  Rechargeable Ni-MH batteries EN-MH2-B4 (set of four EN-MH2 batteries)<sup>1</sup></p>
<p><b>Battery charger</b></p>	<p>Battery Charger MH-72 (includes two rechargeable Ni-MH batteries EN-MH2)<sup>1</sup>                  Battery Charger MH-73 (includes four rechargeable Ni-MH batteries EN-MH2)<sup>1</sup></p>
<p><b>AC adapter</b></p>	<p>AC Adapter EH-65A (connect as shown)</p>  <p>AC Adapter EH-62B cannot be used.</p>
<p><b>USB Cable</b></p>	<p>USB Cable UC-E6<sup>2</sup></p>
<p><b>Audio/video cable</b></p>	<p>Audio Video Cable EG-CP14</p>

<sup>1</sup> To charge EN-MH2 batteries, use only Battery Charger MH-72 or MH-73. Do not use these battery chargers to charge any other type of battery.

<sup>2</sup> Supplied with this camera (→ Page 3 of the Quick Start Guide).

## Approved Memory Cards

The following Secure Digital (SD) memory cards have been tested and approved for use in this camera.

All cards of the designated make and capacity listed below can be used, regardless of the speed for transferring internal data.

	SD memory card	SDHC memory card <sup>2</sup>	SDXC memory card <sup>3</sup>
SanDisk	2 GB <sup>1</sup>	4 GB, 8 GB, 16 GB, 32 GB	64 GB
TOSHIBA	2 GB <sup>1</sup>	4 GB, 8 GB, 16 GB, 32 GB	64 GB
Panasonic	2 GB <sup>1</sup>	4 GB, 8 GB, 12 GB, 16 GB, 24 GB, 32 GB	48 GB, 64 GB
Lexar	2 GB <sup>1</sup>	4 GB, 8 GB, 16 GB, 32 GB	–

<sup>1</sup> If the memory card will be used with a card reader or similar device, check that device supports 2 GB cards.

<sup>2</sup> SDHC compliant.

If the memory card will be used with a card reader or similar device, check that device supports SDHC.



<sup>3</sup> SDXC compliant.

If the memory card will be used with a card reader or similar device, check that device supports SDXC.





- Contact the manufacturer for details on the above cards.

## File and Folder Names

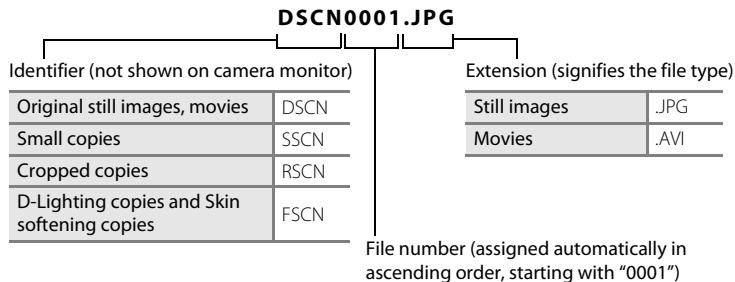









Images and movies are assigned file names as follows.









- Files are saved in folders named with a folder number followed by a five-character identifier: "P\_" plus a three-digit sequence number for images captured using panorama assist (e.g. "101P\_001";  41) and "NIKON" for all other images (e.g. "100NIKON"). When the number of files within a folder reaches 9999, a new folder will be created. File numbers will be assigned automatically starting with "0001".
- Files copied using **Copy > Selected images** are copied to the current folder, where they are assigned new file numbers in ascending order starting from the largest file number in memory. **Copy > All images** copies all folders from the source medium; file names do not change but new folder numbers are assigned in ascending order, starting from the largest folder number on the destination medium ( 68).
- Folders can hold up to 200 images; if an image is captured when the current folder contains 200 images, a new folder will be created by adding one to the current folder number. If an image is captured when the current folder is numbered 999 and contains 200 images or an image numbered 9999, no further images can be captured until the medium is formatted ( 105) or a new memory card inserted.







## Error Messages

The following table lists the error messages and other warnings displayed in the monitor, as well as the solutions for dealing with them.









Display	Problem	Solution	
 (blinks)	Clock not set.	Set clock.	94
 Battery exhausted.	Battery exhausted.	Replace the batteries.	12, 111
 (blinks red)	Camera cannot focus.	<ul style="list-style-type: none"> <li>• Refocus.</li> <li>• Use focus lock.</li> </ul>	22, 23, 46
 Please wait for the camera to finish recording.	Camera cannot perform other operations until saving is complete.	Wait until message clears from display automatically when saving is complete.	23
 Memory card is write protected.	Write-protect switch is in "lock" position.	Slide write-protect switch to "write" position.	17
 This card cannot be used.	Error accessing memory card.	<ul style="list-style-type: none"> <li>• Use approved card.</li> <li>• Check that connectors are clean.</li> <li>• Confirm that memory card is correctly inserted.</li> </ul>	117
 This card cannot be read.			16
 Card is not formatted. Format card?  Yes No	Memory card has not been formatted for use in COOLPIX L23.	All data saved on the memory card will be deleted. If there is any data on the card that you want to keep, select <b>No</b> , and backup the data to a computer before formatting the memory card. To format the memory card, select <b>Yes</b> and press  .	17
 Out of memory.	Memory card is full.	<ul style="list-style-type: none"> <li>• Choose smaller image mode.</li> <li>• Delete images.</li> <li>• Insert new memory card.</li> <li>• Remove memory card and use internal memory.</li> </ul>	49 25, 78 16 16

## Error Messages

Display	Problem	Solution	
 Image cannot be saved.	Error occurred while saving images.	Format internal memory or memory card.	105
	Camera has run out of file numbers.	<ul style="list-style-type: none"> <li>• Replace the memory card.</li> <li>• Format internal memory or memory card.</li> </ul>	16 105
	Image cannot be used for welcome screen.	Image copies created using crop or small picture that are 320 × 240 or smaller, or images captured at an <b>Image mode</b> setting of  <b>3584×2016</b> cannot be selected.	93
	There is not enough memory to copy the image.	Delete images from destination.	25
 A blink was detected in the picture just taken.	The image saved may contain a subject who have blinked.	View the image to confirm it.	45
 Image cannot be modified.	You are trying to edit an image that cannot be edited.	<ul style="list-style-type: none"> <li>• Confirm the conditions that are required for editing.</li> <li>• These options cannot be used with movies.</li> </ul>	69 –
 Cannot record movie.	Time out error while recording movie.	Choose memory card with faster write speed.	16
 Memory contains no images.	No images in the internal memory or memory card.	<ul style="list-style-type: none"> <li>• Remove memory card to play back images from internal memory.</li> <li>• To copy image from internal memory to memory card, press the <b>MENU</b> button. The copy screen will be displayed and images in the internal memory can be copied to memory card.</li> </ul>	16
			68

Display	Problem	Solution	
 File contains no image data.	File not created with COOLPIX L23.	File cannot be viewed on this camera. View file using the computer or any other devices which was used to create or edit this file.	–
 This file cannot be played back.			
 All images are hidden.	No images available for a slide show.	–	64
 This image cannot be deleted.	Image is protected.	Disable protection.	65
 Travel destination is in the current time zone.	Destination in same time zone as home.	–	94
Lens error 	Lens error.	Turn camera off and then on again. If error persists, contact retailer or Nikon-authorized service representative.	18
 Communications error	Error occurred during communication with printer.	Turn camera off, reconnect USB cable.	86
System error 	Error has occurred in camera's internal circuitry.	Turn camera off, remove and reinsert batteries, and turn camera on. If error persists, contact retailer or Nikon-authorized service representative.	12, 18
 Printer error: check printer status.	Printer error.	Check printer. After checking the ink or solving the problem, select <b>Resume</b> and press the  button to resume printing.*	–
 Printer error: check paper	Specified size of paper is not loaded in printer.	Load the specified paper, select <b>Resume</b> and press the  button to resume printing.*	–
 Printer error: paper jam	Paper has jammed in the printer.	Eject the jammed paper, select <b>Resume</b> and press the  button to resume printing.*	–

## Error Messages

Display	Problem	Solution	
 Printer error: out of paper	No paper is loaded in printer.	Load the specified paper, select <b>Resume</b> and press the  button to resume printing.*	–
 Printer error: check ink	Ink error.	Check ink, select <b>Resume</b> and press the  button to resume printing.*	–
 Printer error: out of ink	Ink cartridge is empty.	Replace ink, select <b>Resume</b> and press the  button to resume printing.*	–
 Printer error: file corrupt	An error caused by the image file has occurred.	Select <b>Cancel</b> and press the  button to cancel printing.	–

\* See the documentation provided with your printer for further guidance and information.

# Troubleshooting

If the camera fails to function as expected, check the list of common problems below before consulting your retailer or Nikon-authorized service representative. Refer to the page numbers in the right-most column for more information.



## Display, Settings, and Power Supply



Problem	Cause/Solution	
Monitor is blank.	• Camera is off.	18
	• Battery exhausted.	18
	• Standby mode for saving power: Press the shutter-release button halfway.	13, 22
	• When flash lamp blinks red, wait until flash has charged.	27
	• Camera and computer are connected via USB cable.	81
Monitor is hard to read.	• Camera and TV are connected via audio/video cable.	79
	• Adjust monitor brightness.	98
Camera turns off without warning.	• Monitor is dirty. Clean monitor.	114
	• Battery exhausted.	18
Date and time of shooting are not correct.	• Camera has turned off automatically to save power.	104
	• Battery is cold.	113
	• If camera clock has not been set, Date not set indicator blinks with shooting and movie recording. Images and movies saved before clock is set are dated "00/00/0000 00:00" or "01/01/2011 00:00" respectively. Set the correct date and time using <b>Time zone and date</b> in the setup menu.	14
No indicators displayed in monitor.	• Check camera clock regularly against more accurate timepieces and reset as required.	94
	<b>Hide info</b> is selected for <b>Photo info</b> . Select <b>Show info</b> .	98
<b>Print date</b> not available.	<b>Time zone and date</b> has not been set.	14, 94
Date not appearing on images even when <b>Print date</b> is enabled.	• The current shooting mode is one that does not support Print date. • The date cannot be imprinted on movies.	100
Screen for setting the time zone and date is displayed when the camera is turned on.	The clock battery is exhausted; all settings were restored to their default values.	96
Camera settings reset.		





## Electronically Controlled Cameras

In extremely rare instances, unusual characters may appear in the monitor and the camera may stop functioning. In most cases, this phenomenon is caused by a strong external static charge. Turn the camera off, remove and replace the battery, then turn the camera on again. In the event of continued malfunction, contact your retailer or Nikon-authorized service representative. Note that disconnecting the power source as described above may result in the loss of any data not saved to internal memory or the memory card at the time the problem occurred. Data already saved will not be affected.

## Shooting

Problem	Cause/Solution	
No image captured when shutter-release button is pressed.	• When camera is in playback mode, press the  button.	30
	• When menus are displayed, press the <b>MENU</b> button.	10
	• Battery exhausted.	18
	• When flash lamp blinks, flash is charging.	27
Cannot switch to shooting mode.	Disconnect the USB cable.	79, 81, 86
Camera cannot focus.	• The subject is too close to the camera. Try shooting with easy auto mode, <b>Close-up</b> scene mode, or macro mode.	18, 31, 37, 47
	• The intended subject is one with which autofocus does not perform well.	23
	• Set <b>AF assist</b> in the setup menu to <b>Auto</b> .	103
	• Focus error. Turn camera off and then on again.	18
Images are blurred.	• Use flash.	26
	• Use electronic vibration reduction or motion detection.	101, 102
	• Use <b>BSS</b> (Best Shot Selector).	53
	• Use tripod and self-timer.	5, 28
Streaks of light or partial discoloration are visible in the monitor.	Smear may occur when the camera is aimed at a bright subject. When using Multi-shot 16 or when recording movies, avoid bright objects such as the sun, reflections of the sun, and electric lights.	53, 75, 115
Bright specks appear in images captured with flash.	Flash is reflecting off particles in air. Set the flash mode setting to  (off).	26

Problem	Cause/Solution	
Flash does not fire.	<ul style="list-style-type: none"> <li>• The flash mode is set to  (off).</li> <li>• Scene mode in which flash does not fire is selected.</li> <li>• <b>Blink proof</b> is set to <b>On</b> in the smart portrait menu.</li> <li>• Another function that restricts flash is enabled.</li> </ul>	26 32 45 55
Optical zoom cannot be used.	Optical zoom cannot be used while recording movies.	76
Digital zoom cannot be used.	Digital zoom cannot be used in the following situations. <ul style="list-style-type: none"> <li>• When <b>Portrait</b> or <b>Night portrait</b> is selected for Scene mode</li> <li>• When using smart portrait mode</li> <li>• When <b>Multi-shot 16</b> is selected for <b>Continuous</b></li> <li>• Just before recording a movie (up to 2x can be applied while recording movies)</li> </ul>	33, 34 43 53 75
<b>Image mode</b> not available.	Another function that restricts the <b>Image mode</b> option is enabled.	55
No sound when shutter is released.	<ul style="list-style-type: none"> <li>• <b>Off</b> is selected for <b>Sound settings &gt; Shutter sound</b> in setup menu. Depending on the current shooting mode or settings, the shutter sound is not heard even when set to <b>On</b>.</li> <li>• Do not block the speaker.</li> </ul>	103 5
AF-assist illuminator does not light.	<b>Off</b> is selected for the <b>AF assist</b> option in the setup menu. AF-assist illuminator may not light depending on the position of the focus area or the current scene mode, even when <b>Auto</b> is selected.	103 33-40
Images appear smeared.	Lens is dirty. Clean lens.	114
Hues are unnatural.	White balance does not match light source.	51
Randomly spaced bright pixels ("noise") appear in image.	The subject is dark, so shutter speed is too slow or ISO sensitivity is too high. <ul style="list-style-type: none"> <li>• Use the flash.</li> </ul>	26
Images are too dark (underexposed).	<ul style="list-style-type: none"> <li>• Flash is off.</li> <li>• Flash window is blocked.</li> <li>• Subject is beyond flash range.</li> <li>• Adjust exposure compensation.</li> <li>• Subject is backlit. Select the <b>Backlighting</b> scene mode, or set the flash mode to  (fill flash).</li> </ul>	26 20 26 29 26, 39

Problem	Cause/Solution	
Images are too bright (overexposed).	Adjust exposure compensation.	29
Unexpected results when flash set to  (auto with red-eye reduction).	When taking pictures with  (auto with red-eye reduction), or when taking pictures with <b>Night portrait</b> (either in easy auto mode or the Night portrait scene mode) and the fill flash with slow sync and red-eye reduction is used, red-eye reduction may be applied, in rare cases, to areas not affected by red-eye. Use any auto mode or scene mode other than <b>Night portrait</b> , and change the flash to any other settings other than  (auto with red-eye reduction) and try shooting again.	31, 26, 34
The skin softening function does not produce the desired result.	<ul style="list-style-type: none"> <li>The desired level of skin softening effect may not be achieved in some shooting conditions.</li> <li>Use <b>Skin softening</b> in the playback menu for images in which four or more faces were captured.</li> </ul>	44 71
Saving images takes time.	<ul style="list-style-type: none"> <li>When the flash mode is set to  (auto with red-eye reduction), it may take more time to save images.</li> <li>When images were captured using the skin softening function</li> </ul>	26 33, 34, 45

## Playback

Problem	Cause/Solution	
File cannot be played back.	<ul style="list-style-type: none"> <li>File was overwritten or renamed by computer or other make of camera.</li> <li>Only movies recorded with COOLPIX L23 can be played back.</li> </ul>	– 75
Cannot zoom in on image.	<ul style="list-style-type: none"> <li>Playback zoom cannot be used with movies, small pictures, or images that have been cropped to 320 × 240 or smaller.</li> <li>The COOLPIX L23 may not be able to zoom in on images captured with another make or model of digital camera.</li> </ul>	–

Problem	Cause/Solution	
Cannot use the D-Lighting, skin softening, small picture or crop options.	<ul style="list-style-type: none"> <li>• These options cannot be used with movies.</li> <li>• Select images that support D-Lighting, skin softening, small picture or crop.</li> <li>• Camera is unable to edit images captured with other cameras.</li> </ul>	78 69 69
Images not displayed on television.	<ul style="list-style-type: none"> <li>• Choose correct <b>Video mode</b>.</li> <li>• Memory card contains no images. Replace memory card. Remove memory card to play back images from internal memory.</li> </ul>	106 16
Nikon Transfer 2 does not start when camera is connected.	<ul style="list-style-type: none"> <li>• Camera is off.</li> <li>• Battery exhausted.</li> <li>• USB cable is not correctly connected.</li> <li>• Camera is not recognized by the computer.</li> <li>• Computer is not set to launch Nikon Transfer 2 automatically. For more information about Nikon Transfer 2, refer to help information contained in ViewNX 2.</li> <li>• Confirm system requirements.</li> </ul>	18 18 81 – 84 80
Images to be printed are not displayed.	Memory card contains no images. Replace memory card. Remove memory card to print images from internal memory.	16
Cannot select paper size with camera.	Even when using a PictBridge compatible printer, paper size cannot be selected from the camera in the following situations. Use the printer to select paper size. <ul style="list-style-type: none"> <li>• The printer does not support the paper sizes used by the camera.</li> <li>• The printer automatically selects the paper size.</li> </ul>	87, 88

# Specifications

## Nikon COOLPIX L23 Digital Camera

Type	Compact digital camera
Effective pixels	10.1 million
Image sensor	1/2.9-in. type CCD; 10.34 million total pixels
Lens	5x optical zoom, NIKKOR lens
Focal length	4.0-20.0mm (angle of view equivalent to that of 28-140 mm lens in 35mm [135] format)
f/-number	f/2.7-6.8
Construction	6 elements in 5 groups
Digital zoom	Up to 4x (angle of view equivalent to that of approx. 560 mm lens in 35mm [135] format)
Vibration reduction	Electronic VR (still pictures)
Autofocus (AF)	Contrast-detect AF
Focus range (from lens)	<ul style="list-style-type: none"><li>• Approx. 30 cm (1 ft.) to ∞ (W); approx. 60 cm (2 ft.) to ∞ (T)</li><li>• Macro mode: 3 cm (1.2 in.) to ∞ (maximum wide-angle position)</li></ul>
Focus-area selection	Center, face detection
Monitor	6.7 cm (2.7-in.), approx. 230k-dot, TFT LCD with 5-level brightness adjustment
Frame coverage (shooting mode)	Approx. 98% horizontal and 98% vertical (compared to actual picture)
Frame coverage (playback mode)	Approx. 100% horizontal and 100% vertical (compared to actual picture)
Storage	
Media	Internal memory (Approx. 22 MB), SD/SDHC/SDXC memory card
File system	DCF, Exif 2.3, and DPOF compliant
File formats	Still pictures: JPEG Movies: AVI (Motion-JPEG compliant)
Image size (pixels)	<ul style="list-style-type: none"><li>• 10M (High) [<b>3648 × 2736 ★</b>]</li><li>• 10M [<b>3648 × 2736</b>]</li><li>• 8M [<b>3264 × 2448</b>]</li><li>• 5M [<b>2592 × 1944</b>]</li><li>• 3M [<b>2048 × 1536</b>]</li><li>• PC [<b>1024 × 768</b>]</li><li>• VGA [<b>640 × 480</b>]</li><li>• 16:9 [<b>3584 × 2016</b>]</li></ul>
ISO sensitivity (Standard output sensitivity)	Auto (ISO 80-1600)

<b>Exposure</b>	
<b>Metering</b>	256-segment matrix, center-weighted (when using a digital zoom setting below 2x), spot (digital zoom 2x or more)
<b>Exposure control</b>	Programmed auto exposure with motion detection and exposure compensation (-2 to +2 EV in steps of 1/3 EV)
<b>Shutter</b>	Mechanical and charge-coupled electronic shutter
<b>Speed</b>	1/2000 - 1 s, 4 s ( <b>Fireworks show</b> scene mode)
<b>Aperture</b>	Electronically-controlled ND filter (-2AV) selection
<b>Range</b>	2 steps (f/2.7 and f/5.4 [W])
<b>Self-timer</b>	Approx. 10 seconds
<b>Built-in flash</b>	
<b>Range (approx.) (ISO sensitivity: Auto)</b>	[W]: 0.3 to 5.0 m (1 ft. to 16 ft.), [T]: 0.6 to 2.0 m (2 ft. to 6 ft. 7 in.)
<b>Flash control</b>	TTL auto flash with monitor preflashes
<b>Interface</b>	Hi-Speed USB
<b>Data transfer protocol</b>	MTP, PTP
<b>Video output</b>	Can be selected from NTSC and PAL
<b>I/O terminal</b>	Audio video output/digital I/O (USB)
<b>Supported languages</b>	Arabic, Chinese (Simplified and Traditional), Czech, Danish, Dutch, English, Finnish, French, Greek, German, Hungarian, Indonesian, Italian, Japanese, Korean, Polish, Portuguese, Norwegian, Romanian, Russian, Spanish, Swedish, Thai, Turkish, Ukrainian
<b>Power sources</b>	<ul style="list-style-type: none"> <li>• Two LR6/L40 (AA-size) alkaline batteries</li> <li>• Two FR6/L91 (AA-size) lithium batteries</li> <li>• Two EN-MH2 rechargeable Ni-MH batteries (available separately)</li> <li>• AC Adapter EH-65A (available separately)</li> </ul>
<b>Battery life</b>	<p>Still pictures*:</p> <ul style="list-style-type: none"> <li>• Approx. 250 shots when using alkaline batteries</li> <li>• Approx. 660 shots when using lithium batteries</li> <li>• Approx. 420 shots when using EN-MH2 batteries</li> </ul> <p>Movies:</p> <ul style="list-style-type: none"> <li>• Approx. 1 h when using alkaline batteries (<b>VGA (640x480)</b>)</li> <li>• Approx. 3 h 45 min when using lithium batteries (<b>VGA (640x480)</b>)</li> <li>• Approx. 2 h 35 min when using EN-MH2 batteries (<b>VGA (640x480)</b>)</li> </ul>
<b>Tripod socket</b>	1/4 (ISO 1222)

## Specifications

Dimensions (W × H × D)	Approx. 96.7 × 59.9 × 29.3 mm (3.9 × 2.4 × 1.2 in.) (excluding projections)
Weight	Approx. 170 g (6.0 oz.) (including batteries and SD memory card)
Operating environment	
Operating temperature	0 to 40°C (32 to 104°F)
Humidity	Less than 85% (no condensation)

- Unless otherwise stated, all figures are for a camera with fully-charged LR6/L40 (AA-size) alkaline batteries operated at an ambient temperature of 25°C (77°F).
- \* Based on Camera and Imaging Products Association (CIPA) standards for measuring the life of camera batteries. Measured at 23 (±2) °C (69 to 77°F); zoom adjusted with each shot, flash fired with every other shot, image mode set to **0. 3648x2736**. Battery life may vary depending on shooting interval and length of time menus and images are displayed. Supplied batteries are for trial use only.

### Specifications

Nikon will not be held liable for any errors this manual may contain.

















The appearance of this product and its specifications are subject to change without notice.

## Supported Standards

- **DCF:** Design Rule for Camera File System is a standard widely used in the digital camera industry to ensure compatibility among different makes of camera.
- **DPOF:** Digital Print Order Format is an industry-wide standard that allows images to be printed from print orders saved on the memory card.
- **Exif version 2.3:** This camera supports Exif (Exchangeable Image File Format for Digital Still Cameras) version 2.3, a standard that allows information saved with photographs to be used for optimal color reproduction when images are output from Exif-compliant printers.
- **PictBridge:** A standard developed cooperatively by the digital camera and printer industries, allowing photographs to be output directly to a printer without connecting the camera to a computer.

# Index

## Symbols

-  (apply selection) button 5, 9
-  (Playback) button 5, 8
-  Auto mode 46
-  Delete button 5, 25, 78
-  D-Lighting 70
-  Easy auto mode 18, 31
-  Exposure compensation 29
-  Flash mode 26
-  Macro mode 47
- MENU** button 5, 10
-  Movie mode 75
-  Playback mode 24
-  Scene mode 32
-  Self-timer 28
-  Smart portrait mode 43
- AE/AF-L** 42
- W** Wide 21
-  Thumbnail playback 57, 58
- T** Tele 21
-  Playback zoom 59
-  Help 32

## A



- AC adapter 13, 116
- AF-assist illumination 4, 23, 103
- Alkaline 13
- Alkaline batteries 12
- Aperture 22
- Audio Video/USB cable 79, 86
- Audio/video cable 79
- Audio-in/Video-in jack 79
- Auto flash 26
- Auto off 13, 104
- Autofocus 23, 46, 47
- AVI 118

## B

- Backlighting  39
- Batteries 12, 96
- Battery level 18

- Battery type 13, 111
- Battery-chamber 5
- Battery-chamber/memory card slot cover 5, 12, 16
- Beach  35
- Best shot selector 53
- Black-and-white 54
- Blink proof 45
- Blink warning 107
- Brightness 98
- BSS 53
- Built-in microphone 4
- Button sound 103

## C

- Calendar display 58
- Close-up  37
- Cloudy 51
- Color options 54
- Compression ratio 49
- Computer 80
- Continuous 53
- Copy  39
- Copying images 68
- Crop 73
- Cyanotype 54



## D

- Date 14, 94
- Date format 15
- Daylight 51
- Daylight saving time 14, 96
- Delete 25, 78
- Digital zoom 21
- Direct print 85
- D-Lighting 69, 70
- DPOF 131
- DPOF printing 90
- DSCN 118
- Dusk/dawn  36

**E**

Easy auto mode 18, 31  
 EH-65A 13  
 Electronic VR 101  
 EN-MH1 13, 116  
 EN-MH2 12, 111, 113, 116  
 Exposure compensation 29  
 Extension 118  
 Eyelet for camera strap 4

**F**

File names 118  
 Fill flash 26  
 Fireworks show  39  
 Firmware version 111  
 Flash 4, 26, 27  
 Flash lamp 5, 27  
 Flash off 26  
 Fluorescent 51  
 Focus 22  
 Focus lock 23, 46  
 Folder names 118  
 Food  38  
 Format 17, 105  
 Format memory card 17, 105  
 Formatting internal memory 105  
 FSCN 118  
 Full-frame playback mode 24

**I**

Identifier 118  
 Image mode 19, 32, 49  
 Incandescent 51  
 Indicator lamp 5  
 Internal memory 16  
 ISO sensitivity 27

**J**

JPG 118



**L**

Landscape  33  
 Language 106  
 Lens 4, 128  
 Lithium batteries 12

**M**

Macro mode 47  
 Memory capacity 18  
 Memory card 16, 117  
 Memory card slot 5, 16  
 Monitor 5, 6, 114  
 Monitor settings 98  
 Motion detection 102  
 Movie menu 75, 76  
 Movie playback 78  
 Movie settings 76  
 Multi selector 5, 9  
 Multi-shot 16 53  
 Museum  38



**N**

Nickel-metal hydride batteries 12  
 Night landscape  36  
 Night portrait  34  
 Nikon Transfer 2 80, 82, 84  
 Number of exposures remaining 18, 50

**O**

Optical zoom 21  
 Optional accessories 116

**P**

Panorama assist  40, 41  
 Panorama Maker 5 80, 84  
 Paper size 87, 88  
 Party/indoor  35  
 Photo info 98  
 PictBridge 85, 131  
 Playback 24, 56, 57, 59, 78  
 Playback button 5, 8

Playback menu 60  
Playback zoom 59  
Portrait  33  
Power 12, 14, 18  
Power switch 4, 12, 18  
Power-on lamp 12, 18  
Preset manual 52  
Print 61, 87, 88  
Print date 100  
Print order 61  
Print order (Date) 62  
Printer 85  
Protect 65

### **Q**



QVGA (320x240) 77

### **R**

Recording movies 75  
Red-eye reduction 26, 27  
Reset all 109  
Rotate image 67  
RSCN 118

### **S**

Scene mode 32, 33  
Self-timer 28  
Self-timer lamp 4, 28  
Sepia 54  
Setup menu 91  
Shooting 18, 20, 22  
Shooting menu 48  
Shooting mode button 5, 8  
Shooting-mode selection menu 30  
Shutter sound 103  
Shutter speed 22  
Shutter-release button 4, 11, 22  
Single 53  
Skin softening 45, 71  
Sleep mode 104  
Slide show 64

Slow sync 26  
Small picture 72  
Smart portrait mode 43  
Snow  35  
Sound settings 103  
Speaker 4  
Sports  34  
SSCN 118  
Standard color 54  
Strap 4  
Sunset  36

### **T**

Tabs 11  
Thumbnail playback 57  
Time zone 14, 94, 97  
Time zone and date 94  
Tripod socket 5  
TV 79

### **U**

USB cable 81  
USB connector and audio/video output 5, 79, 86  
USB/audio/video output connector 80, 81

### **V**

VGA (640x480) 77  
Video mode 106  
ViewNX 2 80, 84  
Vivid color 54  
Volume 78

### **W**

Welcome screen 93  
White balance 51

### **Z**

Zoom button 4, 78



# ***Nikon***

No reproduction in any form of this manual, in whole or in part (except for brief quotation in critical articles or reviews), may be made without written authorization from NIKON CORPORATION.



**NIKON CORPORATION**

---

© 2011 Nikon Corporation

CT1A01(11)  
6MM03911-01