

Nikon

DIGITAL CAMERA

COOLPIX A300

Reference Manual



Quick Topic Search

-
- Read this manual thoroughly before using the camera.
 - To ensure proper use of the camera, be sure to read "For Your Safety" (page vi).
 - After reading this manual, keep it in a readily accessible place for future reference.

En

Quick Topic Search

You can return to this page by tapping or clicking  in the lower right of any page.

Main Topics

Introduction	iii
Table of Contents	ix
Parts of the Camera	1
Getting Started.....	7
Basic Shooting and Playback Operations	14
Connecting to a Smart Device (SnapBridge).....	21
Shooting Features.....	30
Playback Features.....	64
Movies	75
Connecting the Camera to a TV, Printer, or Computer.....	80
Using the Menu.....	90
Technical Notes.....	133

Common Topics



For Your Safety



Connecting to a
Smart Device



Selecting a
Shooting Mode



Special Effects
Mode



Smart Portrait
Mode



Editing Images
(Still Images)



Troubleshooting



Index



Introduction

Read This First

Thank you for purchasing the Nikon COOLPIX A300 digital camera.

Symbols and Conventions Used in This Manual

- Tap or click  in the lower right of each page to display “Quick Topic Search” (ii).
- Symbols

Symbol	Description
	This icon marks cautions and information that should be read before using the camera.
	This icon marks notes and information that should be read before using the camera.
	This icon marks other pages containing relevant information.

- SD, SDHC, and SDXC memory cards are referred to as “memory cards” in this manual.
- Smartphones and tablets are referred to as “smart device” in this manual.
- The setting at the time of purchase is referred to as the “default setting.”
- The names of menu items displayed on the camera screen, and the names of buttons or messages displayed on a computer monitor appear in bold.
- In this manual, images are sometimes omitted from screen display samples so that screen indicators can be more clearly shown.



Information and Precautions

Life-Long Learning

As part of Nikon's "Life-Long Learning" commitment to ongoing product support and education, continually updated information is available online at the following websites:

- For users in the U.S.A.: <http://www.nikonusa.com/>
- For users in Europe: <http://www.europe-nikon.com/support/>
- For users in Asia, Oceania, the Middle East, and Africa: <http://www.nikon-asia.com/>

Visit these websites to keep up-to-date with the latest product information, tips, answers to frequently asked questions (FAQs), and general advice on digital imaging and photography. Additional information may be available from the Nikon representative in your area. Visit the website below for contact information.

<http://imaging.nikon.com/>

Use Only Nikon Brand Electronic Accessories

Nikon COOLPIX cameras are designed to the highest standards and include complex electronic circuitry. Only Nikon brand electronic accessories (including battery chargers, batteries, AC adapters, and USB cables) certified by Nikon specifically for use with this Nikon digital camera are engineered and proven to operate within the operational and safety requirements of this electronic circuitry.

THE USE OF NON-NIKON ELECTRONIC ACCESSORIES COULD DAMAGE THE CAMERA AND MAY VOID YOUR NIKON WARRANTY.

The use of third-party rechargeable Li-ion batteries not bearing the Nikon holographic seal could interfere with normal operation of the camera or result in the batteries overheating, igniting, rupturing, or leaking.

Holographic seal: Identifies this device as an authentic Nikon product.



For more information about Nikon brand accessories, contact a local authorized Nikon dealer.

Before Taking Important Pictures

Before taking pictures on important occasions (such as at weddings or before taking the camera on a trip), take a test shot to ensure that the camera is functioning normally. Nikon will not be held liable for damages or lost profits that may result from product malfunction.



About the Manuals

- No part of the manuals included with this product may be reproduced, transmitted, transcribed, stored in a retrieval system, or translated into any language in any form, by any means, without Nikon's prior written permission.
- Illustrations and screen content shown in this manual may differ from the actual product.
- Nikon reserves the right to change the specifications of the hardware and software described in these manuals at any time and without prior notice.
- Nikon will not be held liable for any damages resulting from the use of this product.
- While every effort was made to ensure that the information in these manuals is accurate and complete, we would appreciate it were you to bring any errors or omissions to the attention of the Nikon representative in your area (address provided separately).

Comply with Copyright Notices

Under copyright law, photographs or recordings of copyrighted works made with the camera can not be used without the permission of the copyright holder. Exceptions apply to personal use, but note that even personal use may be restricted in the case of photographs or recordings of exhibits or live performances.

Disposing of Data Storage Devices

Please note that deleting images or formatting data storage devices such as memory cards or built-in camera memory does not completely erase the original image data. Deleted files can sometimes be recovered from discarded storage devices using commercially available software, potentially resulting in the malicious use of personal image data. Ensuring the privacy of such data is the user's responsibility.

Before discarding a data storage device or transferring ownership to another person, be sure to perform **Reset all** in the setup menu (📖91) to reset camera settings. After that, erase all data using commercial deletion software or perform **Format card/Format memory** in the setup menu to format the device, then completely refill it with images containing no private information (for example, images of empty sky).

Care should be taken to avoid injury or damage to property when physically destroying memory cards.

Conformity Marking

Follow the procedure below to display some of the conformity markings that the camera complies with.

Press the **MENU** button → **Y** menu icon → Conformity marking → **OK** button



For Your Safety

To prevent damage to property or injury to yourself or to others, read "For Your Safety" in its entirety before using this product.

Keep these safety instructions where all those who use this product will read them.



DANGER

Failure to observe the precautions marked with this icon carries a high risk of death or severe injury.



WARNING

Failure to observe the precautions marked with this icon could result in death or severe injury.



CAUTION

Failure to observe the precautions marked with this icon could result in injury or property damage.



WARNING

- Do not use while walking or operating a motor vehicle. Failure to observe this precaution could result in accidents or injury.
- Do not disassemble or modify this product. Do not touch internal parts that become exposed as the result of a fall or other accident. Failure to observe these precautions could result in electric shock or other injury.
- Should you notice any abnormalities such as the product producing smoke, heat, or unusual odors, immediately disconnect the battery or power source. Continued operation could result in fire, burns or other injury.
- Keep dry. Do not handle with wet hands. Do not handle the plug with wet hands. Failure to observe these precautions could result in fire or electric shock.
- Do not let your skin remain in prolonged contact with this product while it is on or plugged in. Failure to observe this precaution could result in low-temperature burns.
- Do not use this product in the presence of flammable dust or gas such as propane, gasoline or aerosols. Failure to observe this precaution could result in explosion or fire.
- Do not aim the flash at the operator of a motor vehicle. Failure to observe this precaution could result in accidents.



- Keep this product out of reach of children. Failure to observe this precaution could result in injury or product malfunction. In addition, note that small parts constitute a choking hazard. Should a child swallow any part of this product, seek immediate medical attention.
- Do not entangle, wrap or twist the straps around your neck. Failure to observe this precaution could result in accidents.
- Do not use batteries, chargers, or AC adapters not specifically designated for use with this product. When using batteries, chargers, and AC adapters designated for use with this product, do not:
 - Damage, modify, forcibly tug or bend the cords or cables, place them under heavy objects, or expose them to heat or flame.
 - Use travel converters or adapters designed to convert from one voltage to another or with DC-to-AC inverters.Failure to observe these precautions could result in fire or electric shock.
- Do not handle the plug when charging the product or using the AC adapter during thunderstorms. Failure to observe this precaution could result in electric shock.
- Do not handle with bare hands in locations exposed to extremely high or low temperatures. Failure to observe this precaution could result in burns, or frostbite.



CAUTION

- Turn this product off when its use is prohibited. Disable wireless features when the use of wireless equipment is prohibited. The radio-frequency emissions produced by this product could interfere with equipment onboard aircraft or in hospitals or other medical facilities.
- Remove the battery and disconnect the AC adapter if this product will not be used for an extended period. Failure to observe this precaution could result in fire or product malfunction.
- Do not touch moving parts of the lens or other moving parts. Failure to observe this precaution could result in injury.
- Do not fire the flash in contact with or in close proximity to the skin or objects. Failure to observe this precaution could result in burns or fire.
- Do not leave product where it will be exposed to extremely high temperatures, for an extended period such as in an enclosed automobile or in direct sunlight. Failure to observe this precaution could result in fire or product malfunction.





DANGER for Rechargeable Batteries

- Do not mishandle batteries. Failure to observe the following precautions could result in the batteries leaking, overheating, rupturing, or catching fire:
 - Use only rechargeable batteries approved for use in this product.
 - Do not expose batteries to flame or excessive heat.
 - Do not disassemble.
 - Do not short circuit the terminals by touching them to necklaces, hairpins, or other metal objects.
 - Do not expose batteries or the products in which they are inserted to powerful physical shocks.
- Do not attempt to recharge the EN-EL19 rechargeable batteries by using a camera or charger that is not specifically designed to recharge the EN-EL19. Failure to observe this precaution could result in the batteries leaking, overheating, rupturing, or catching fire.
- If battery liquid comes into contact with the eyes, rinse with plenty of clean water and seek immediate medical attention. Delaying action could result in eye injuries.



WARNING for Rechargeable Batteries

- Keep batteries out of reach of children. Should a child swallow a battery, seek immediate medical attention.
- Do not immerse batteries in water or expose to rain. Failure to observe this precaution could result in fire or product malfunction. Immediately dry the product with a towel or similar object should it become wet.
- Discontinue use immediately should you notice any changes in the batteries, such as discoloration or deformation. Cease charging EN-EL19 rechargeable batteries if they do not charge in the specified period of time. Failure to observe this precaution could result in the batteries leaking, overheating, rupturing, or catching fire.
- Prior to disposal, insulate battery terminals with tape. Overheating, rupture, or fire may result should metal objects come into contact with the terminals. Recycle or dispose of batteries in accord with local regulations.
- If battery liquid comes into contact with a person's skin or clothing, immediately rinse the affected area with plenty of clean water. Failure to observe this precaution could result in skin irritation.



Table of Contents

Quick Topic Search	ii
Main Topics.....	ii
Common Topics	ii
Introduction	iii
Read This First	iii
Symbols and Conventions Used in This Manual	iii
Information and Precautions.....	iv
For Your Safety	vi
Parts of the Camera	1
The Camera Body.....	2
The Monitor	4
For Shooting.....	4
For Playback.....	6
Getting Started.....	7
How to Attach the Camera Strap	8
Inserting the Battery and Memory Card.....	9
Removing the Battery or Memory Card	9
Memory Cards and Internal Memory	9
Charging the Battery	10
Camera Setup.....	12
Basic Shooting and Playback Operations	14
Shooting Images.....	15
Recording Movies	17
Playing Back Images	18
Deleting Images	19
The Image Selection Screen for Deletion	20
Connecting to a Smart Device (SnapBridge).....	21
Installing the SnapBridge App.....	22
Connecting the Camera and a Smart Device	23
Disabling or Enabling the Wireless Connection	26
Image Upload and Remote Photography.....	27
Image Upload.....	27
Remote Photography	28



If a Dialog Related to Wi-Fi Connections Is Displayed in iOS.....	28
If Images Cannot Be Uploaded Successfully.....	29
Shooting Features.....	30
Selecting a Shooting Mode.....	31
📷 (Auto) Mode.....	32
Using the Creative Slider.....	32
📷 (Scene Auto Selector) Mode.....	34
Scene Mode (Shooting Suited to the Shooting Conditions).....	35
Tips and Notes About Scene Mode.....	36
Using Skin Softening.....	38
Shooting with Panorama Assist.....	39
Playback with Panorama Assist.....	41
Special Effects Mode (Applying Effects When Shooting).....	42
Smart Portrait Mode (Enhancing Human Faces When Shooting).....	44
Using Smile Timer.....	46
Using Self-Collage.....	47
Setting Shooting Functions with the Multi Selector.....	49
Flash Mode.....	50
Self-timer.....	52
Macro Mode (Taking Close-up Pictures).....	54
Exposure Compensation (Adjusting Brightness).....	55
Using the Zoom.....	56
Focusing.....	57
The Shutter-release Button.....	57
Using Target Finding AF.....	57
Using Face Detection.....	58
Subjects Not Suitable for Autofocus.....	59
Focus Lock.....	60
Default Settings (Flash, Self-timer, Etc.).....	61
Functions That Cannot Be Used Simultaneously When Shooting.....	63
Playback Features.....	64
Playback Zoom.....	65
Thumbnail Playback/Calendar Display.....	66
List by Date Mode.....	67
Editing Images (Still Images).....	68
Before Editing Images.....	68
Quick Effects: Changing Hue or Mood.....	68
Quick Retouch: Enhancing Contrast and Saturation.....	69
D-Lighting: Enhancing Brightness and Contrast.....	69
Red-eye Correction: Correcting Red-eye When Shooting with the Flash.....	70



Glamour Retouch: Enhancing Human Faces.....	71
Small Picture: Reducing the Size of an Image.....	73
Crop: Creating a Cropped Copy.....	74
Movies.....	75
Basic Operations of Movie Recording and Movie Playback.....	76
Operations During Movie Playback.....	79
Connecting the Camera to a TV, Printer, or Computer.....	80
Utilizing Images.....	81
Viewing Images on a TV.....	82
Printing Images Without a Computer.....	83
Connecting the Camera to a Printer.....	83
Printing Images One at a Time.....	84
Printing Multiple Images.....	85
Transferring Images to a Computer (ViewNX-i).....	87
Installing ViewNX-i.....	87
Transferring Images to a Computer.....	87
Using the Menu.....	90
Menu Operations.....	91
The Image Selection Screen.....	93
Menu Lists.....	94
The Shooting Menu.....	94
The Smart Portrait Menu.....	95
The Movie Menu.....	95
The Playback Menu.....	96
The Network Menu.....	96
The Setup Menu.....	97
The Shooting Menu (The Common Shooting Options).....	98
Image Mode (Image Size and Quality).....	98
The Shooting Menu (📷 (Auto) Mode).....	100
White Balance (Adjusting Hue).....	100
Continuous Shooting.....	102
ISO Sensitivity.....	103
AF Area Mode.....	104
Autofocus Mode.....	107
The Smart Portrait Menu.....	108
Self-Collage.....	108
Blink Proof.....	109
The Playback Menu.....	110
Mark for Upload.....	110



Slide Show	111
Protect.....	112
Rotate Image.....	112
Copy (Copy Between the Memory Card and Internal Memory).....	113
The Movie Menu	114
Movie Options.....	114
Autofocus Mode.....	115
Movie VR	116
Wind Noise Reduction	116
The Network Menu	117
Operating the Text Input Keyboard.....	118
The Setup Menu	119
Time Zone and Date	119
Monitor Settings.....	121
Date Stamp	123
Photo VR	124
AF Assist	125
Digital Zoom	125
Sound Settings.....	126
Auto Off.....	126
Format Card/Format Memory	127
Language	128
Image Comment	128
Copyright Information	129
Location Data	130
Video Mode.....	130
Charge by Computer	131
Reset All.....	132
Conformity Marking.....	132
Firmware Version.....	132
Technical Notes.....	133
Notices.....	134
Notes About Wireless Communication Functions	136
Caring for the Product	139
The Camera.....	139
The Battery	140
The Charging AC Adapter.....	141
Memory Cards.....	142
Cleaning and Storage.....	143
Cleaning.....	143
Storage.....	143



Error Messages.....	144
Troubleshooting.....	148
File Names.....	157
Optional Accessories.....	158
Specifications.....	159
Memory Cards That Can Be Used.....	163
Index.....	165



Parts of the Camera

The Camera Body	2
The Monitor	4



The Camera Body

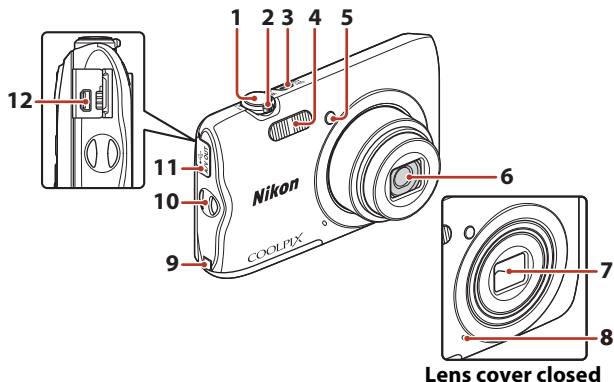

Lens cover closed

1	Shutter-release button.....	16	6	Lens
	Zoom control.....	56	7	Lens cover
	W : Wide-angle.....	56	8	Built-in microphone
2	T : Telephoto.....	56	9	Power connector cover (for connection with optional AC adapter)
	: Thumbnail playback.....	66	10	Eyelet for camera strap.....
	: Playback zoom.....	65	11	Connector cover.....
3	Power switch/power-on lamp.....	12	12	USB/audio/video output connector.....
4	Flash.....	50		81
5	Self-timer lamp.....	53		
	AF-assist illuminator			



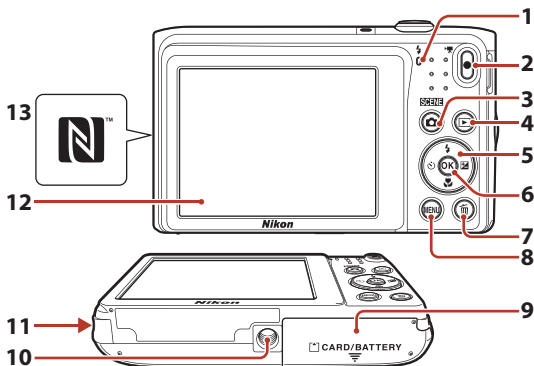

1	Charge lamp.....	10	8	MENU (menu) button.....	91
	Flash lamp.....	50	9	Battery-chamber/ memory card slot cover.....	9
2	● (movie-record) button.....	17	10	Tripod socket.....	161
3	📷 (shooting mode) button	31, 32, 35, 42, 44	11	Speaker	
4	▶ (playback) button.....	18	12	Monitor.....	4
5	Multi selector.....	91	13	N-Mark (NFC antenna).....	23
6	OK (apply selection) button.....	91			
7	🗑️ (delete) button.....	19			



The Monitor

The information that is displayed on the shooting or playback screen changes depending on the camera's settings and state of use.

By default, information is displayed when the camera is turned on and when you operate the camera, and turns off after a few seconds (when **Photo info** is set to **Auto info** in **Monitor settings** (📖121)).

For Shooting

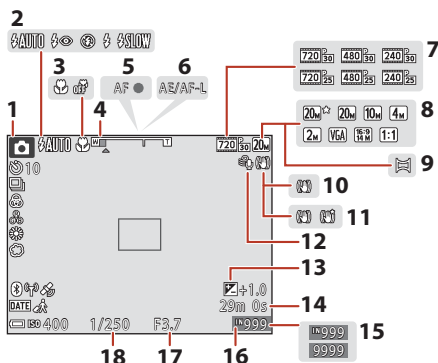

1	Shooting mode	31, 32, 35, 42, 44	11	Movie VR icon.....	116
2	Flash mode.....	50	12	Wind noise reduction	116
3	Macro mode.....	54	13	Exposure compensation value	55
4	Zoom indicator	54, 56	14	Remaining movie recording time	76, 77
5	Focus indicator.....	16	15	Number of exposures remaining (still images).....	16
6	AE/AF-L indicator	40	16	Internal memory indicator	16
7	Movie options	114	17	F-number	57
8	Image mode.....	98	18	Shutter speed.....	57
9	Panorama assist.....	39			
10	Photo VR icon	124			



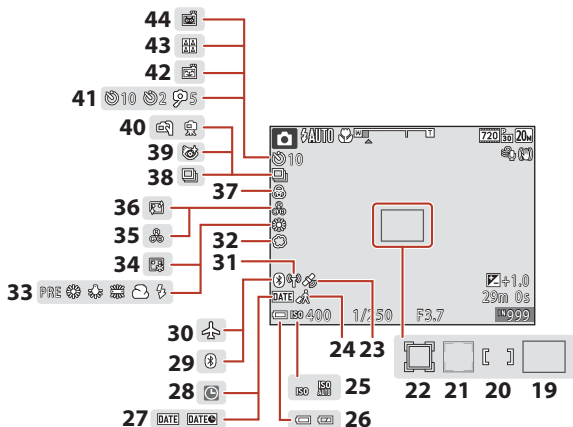

19	Focus area (target finding AF)57, 105	30	Airplane mode117
20	Focus area (manual or center)60, 104	31	Wi-Fi communication indicator117
21	Focus area (face detection, pet detection).....38, 44, 58, 104	32	Soft.....44
22	Focus area (subject tracking)105, 106	33	White balance100
23	Location data130	34	Foundation makeup.....44
24	Travel destination icon119	35	Hue.....32
25	ISO sensitivity103	36	Skin softening.....44
26	Battery level indicator16	37	Vividness.....32, 44
27	Date stamp123	38	Continuous shooting mode102
28	"Date not set" indicator149	39	Blink proof icon109
29	Bluetooth communication indicator117	40	Hand-held/tripod.....36
		41	Self-timer indicator.....52
		42	Smile timer46
		43	Self-Collage47
		44	Pet portrait auto release.....37



For Playback

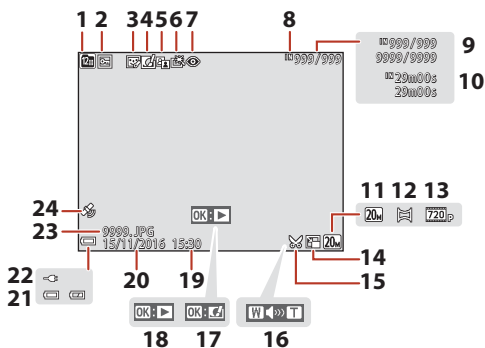

1	List by date icon	67	13	Movie options	114
2	Protect icon	112	14	Small picture icon	73
3	Glamour retouch icon	71	15	Crop icon	65, 74
4	Quick effects icon	68	16	Volume indicator	79
5	D-Lighting icon	69	17	Quick effects guide	
6	Quick retouch icon	69	18	Panorama assist playback guide	
7	Red-eye correction icon	70		Movie playback guide	
8	Internal memory indicator	16	19	Time of recording	
9	Current image number/ total number of images		20	Date of recording	
10	Movie length or elapsed playback time		21	Battery level indicator	16
11	Image mode	98	22	Charging AC Adapter connection indicator	
12	Panorama assist	39	23	File number and type	157
24	Recorded location data indicator	130			



Getting Started

How to Attach the Camera Strap.....	8
Inserting the Battery and Memory Card.....	9
Charging the Battery.....	10
Camera Setup.....	12



How to Attach the Camera Strap

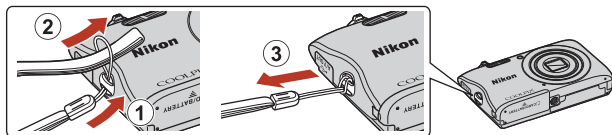

Inserting the Battery and Memory Card

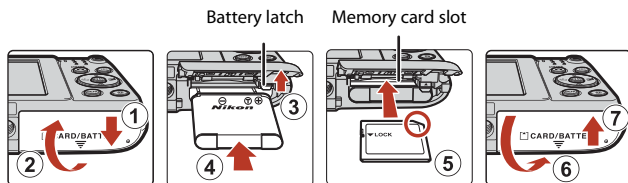

- With the battery's positive and negative terminals oriented correctly, move the orange battery latch (③), and fully insert the battery (④).
- Slide the memory card in until it clicks into place (⑤).
- Be careful not to insert the battery or memory card upside-down or backward, as this could cause a malfunction.

✓ Formatting a Memory Card

The first time you insert a memory card that has been used in another device into this camera, make sure to format it with this camera.

- **Note that formatting a memory card permanently deletes all images and other data on the memory card.** Be sure to make copies of any images you wish to keep before formatting the memory card.
- Insert the memory card into the camera, press the **MENU** button, and select **Format card** in the setup menu (📖91).

Removing the Battery or Memory Card

Turn the camera off and make sure that the power-on lamp and screen have turned off, and then open the battery-chamber/memory card slot cover.

- Move the battery latch to eject the battery.
- Gently push the memory card into the camera to partially eject the memory card.
- Be careful when handling the camera, battery, and memory card immediately after using the camera, as they may be hot.

Memory Cards and Internal Memory

Camera data, including images and movies, can be saved either on a memory card or in the camera's internal memory. To use the camera's internal memory, remove the memory card.



Charging the Battery

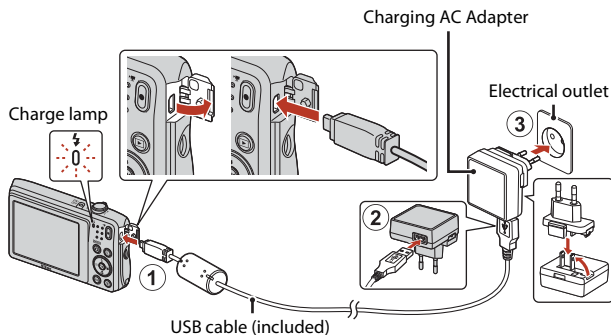

If a plug adapter* is included with your camera, securely connect it to the Charging AC Adapter. Once the two are connected, attempting to forcibly remove the plug adapter could damage the product.

- * The shape of the plug adapter varies according to the country or region in which the camera was purchased. This step can be omitted if the plug adapter comes permanently bonded to the Charging AC Adapter.
- Charging starts when the camera is connected to an electrical outlet while the battery is inserted, as shown in the illustration. The charge lamp slowly flashes while the battery is charging.
- When charging is complete, the charge lamp turns off. Unplug the Charging AC Adapter from the electrical outlet, and disconnect the USB cable. Charging time is about 2 hours and 40 minutes for a fully exhausted battery.
- The battery cannot be charged when the charge lamp quickly flashes, possibly due to one of the reasons described below.
 - The ambient temperature is not suited to charging.
 - The USB cable or Charging AC Adapter is not properly connected.
 - The battery is damaged.



Notes About the USB Cable

Check the shape and direction of the plugs and do not insert or remove the plugs at an angle.

Turning the Camera On While Charging

If you press the power switch while charging with the Charging AC Adapter, the camera turns on in playback mode, and captured images can be played back. Shooting is not possible.

Charging Using a Computer or Battery Charger

- You can also charge the battery by connecting the camera to a computer.
- You can use the MH-66 Battery Charger (available separately) to charge the battery without using the camera.



Camera Setup

1 Press the power switch to turn the camera on.

- Use the multi selector to select and adjust settings.

Power switch

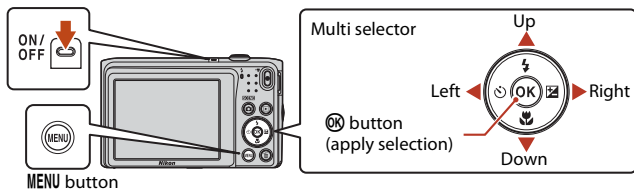

- A language selection dialog will be displayed. Use ▲▼ on the multi selector to highlight a language and press the OK button to select.
- The language can be changed at any time using the **Language** option in the setup menu (📖91).

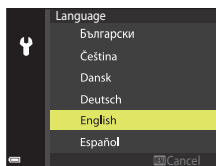

2 When the dialog shown on the right is displayed, press the MENU or OK button as indicated below.

- When not wirelessly connecting to a smart device: Press **MENU** to proceed to step 3.
- When wirelessly connecting to a smart device: Press the **OK** button. See “Connecting to a Smart Device (SnapBridge)” (📖21) for details on the setup procedure.

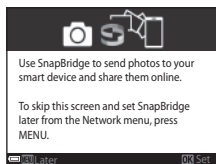

3 Use ▲▼ to choose **Yes** when **Choose time zone and set date and time?** is displayed, and press the OK button.



4 Highlight your home time zone and press the **OK** button.

- To turn daylight saving time on, press ▲. The clock is set ahead one hour and ☀ is displayed at the top of the map. Press ▼ to turn daylight saving time off.

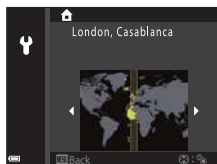

5 Use ▲▼ to choose a date format and press the **OK** button.

6 Enter the current date and time and press the **OK** button.

- Use ◀▶ to highlight items and use ▲▼ to change.
- Press the **OK** button to set the clock.

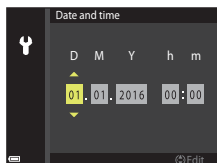

7 When prompted, choose **Yes** and press the **OK** button.

- The shooting screen is displayed when setup is complete.
- You can change the time zone and set the camera clock in **Time zone and date** in the setup menu (📖91).



Basic Shooting and Playback Operations

Shooting Images.....	15
Recording Movies.....	17
Playing Back Images.....	18
Deleting Images.....	19



Shooting Images

SCN (scene auto selector) mode is used here as an example. In **SCN** (scene auto selector) mode, the camera automatically recognizes the shooting scene when you frame a picture, making it easier to take pictures using settings that suit the scene.

1 Hold the camera steady.

- Keep fingers and other objects away from the lens, flash, AF assist-illuminator, microphone, and speaker.
- When taking pictures in portrait (“tall”) orientation, turn the camera so that the flash is above the lens.

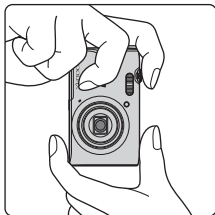
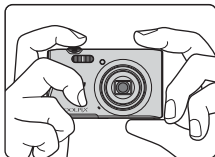



2 Frame the picture.

- Move the zoom control to change the zoom lens position.

Zoom out Zoom in



- When the camera recognizes the shooting scene, the shooting mode icon changes accordingly.
- Battery level indicator
 - : The battery level is high.
 - : The battery level is low.
- Number of exposures remaining
 -  is displayed when no memory card is inserted in the camera, and images are saved in the internal memory.

Shooting mode icon

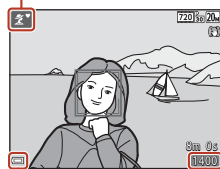

Battery level indicator

Number of exposures remaining

3 Press the shutter-release button halfway.

- To press the shutter-release button "halfway" means to press and hold the button at the point where you feel a slight resistance.
- When the subject is in focus, the focus area or focus indicator is displayed in green.
- When you are using digital zoom, the camera focuses in the center of the frame and the focus area is not displayed.
- If the focus area or focus indicator flashes, the camera is unable to focus. Modify the composition and try pressing the shutter-release button halfway again.

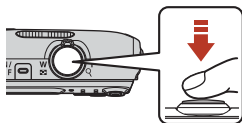

4 Without lifting your finger, press the shutter-release button all the way down.



Notes About Saving Images or Movies

The indicator showing the number of exposures remaining or the indicator showing the remaining recording time flashes while images or movies are being saved. **Do not open the battery-chamber/memory card slot cover or remove the battery or memory card** while an indicator is flashing. Doing this could result in loss of data, or in damage to the camera or the memory card.





The Auto Off Function

- When no operations are performed for about one minute, the screen turns off, the camera enters standby mode, and then the power-on lamp flashes. The camera turns off after remaining in standby mode for about three minutes.
- To turn the screen back on while the camera is in standby mode, perform an operation such as pressing the power switch or shutter-release button.

When Using a Tripod

- We recommend using a tripod to stabilize the camera in the following situations:
 - When shooting in dim lighting with the flash mode (📖49) set to  (off)
 - When the zoom is at a telephoto position
- When using a tripod to stabilize the camera during shooting, set **Photo VR** to **Off** in the setup menu (📖91) to prevent potential errors caused by this function.

Recording Movies

Display the shooting screen and press the  (▶🎥 movie-record) button to start recording a movie. Press the  (▶🎥) button again to end recording.

- To play back a movie, select a movie in full-frame playback mode and press the  button.

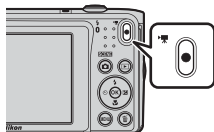

Playing Back Images

1 Press the (playback) button to enter playback mode.

- If you press and hold down the  button while the camera is turned off, the camera turns on in playback mode.





2 Use the multi selector to select an image to display.

- Press and hold down    to scroll through the images quickly.
- To return to shooting mode, press the  button or shutter-release button.

Display the previous image



Display the next image

- When   is displayed in full-frame playback mode, you can press the  button to apply an effect to the image.



- Move the zoom control toward **T** () in full-frame playback mode to zoom in on an image.







- In full-frame playback mode, move the zoom control toward **W** () to switch to thumbnail playback mode and display multiple images on the screen.

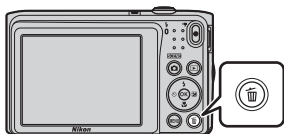

Deleting Images

- 1 Press the  (delete) button to delete the image currently displayed on the screen.



- 2 Use the multi selector   to select the desired deletion method and press the  button.

- To exit without deleting, press the **MENU** button.

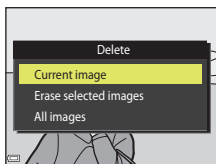

- 3 Select **Yes** and press the  button.

- Deleted images cannot be recovered.

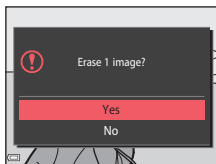

Deleting the Image Captured While in Shooting Mode

When using shooting mode, press the  button to delete the last image that was saved.



The Image Selection Screen for Deletion

1 Use the multi selector ◀▶ to select the image that you want to delete.

- Move the zoom control (📖) toward **T** (🔍) to switch to full-frame playback, or **W** (📐) to switch to thumbnail playback.

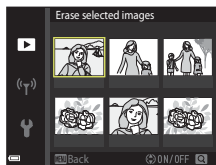

2 Use ▲▼ to select **ON** or **OFF**.

- When **ON** is selected, an icon is displayed under the selected image. Repeat steps 1 and 2 to select additional images.

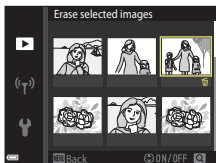

3 Press the **OK** button to apply the image selection.

- A confirmation dialog is displayed. Follow the on-screen instructions to operate.



Connecting to a Smart Device (SnapBridge)

Installing the SnapBridge App.....	22
Connecting the Camera and a Smart Device	23
Image Upload and Remote Photography	27



Installing the SnapBridge App

When you install the SnapBridge app on your smart device and establish a wireless connection between the smart device and a SnapBridge-supported camera, you can upload images captured with the camera to the smart device, or use the smart device to release the camera shutter (📖27).



- This manual describes the procedures for version 2.0 of the SnapBridge app. Use the latest version of the SnapBridge app. The operating procedures may vary depending on the camera's firmware, version of the SnapBridge app, or OS of the smart device.
- See the manual of your smart device for details on how to operate the smart device.

1 Install the SnapBridge app on the smart device.

- Download the app from the Apple App Store® for iOS, and from Google Play™ for Android™. Search for "snapbridge" and then install it.



- Visit the applicable download site for more information about supported OS versions.
- The "SnapBridge 360/170 app" cannot be used with this camera.

2 Enable Bluetooth and Wi-Fi on the smart device.

- **Use the SnapBridge app to connect to the camera. You cannot connect from the Bluetooth settings screen on the smart device.**

Screens in the SnapBridge App

- ① You can view notices from Nikon and the SnapBridge app Help, as well as configure the app's settings.
- ② Primarily perform connection settings for smart devices and cameras.
- ③ You can view, delete, or share the images that are downloaded from the camera.

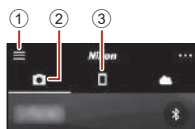

Connecting the Camera and a Smart Device

- Use a sufficiently charged battery so that the camera does not turn off during the procedure.
- Insert a memory card with sufficient free space into the camera.

1 Camera: Select **Network** menu (📖91) → **Connect to smart device**, and press the **OK** button.

- The screen in step 2 is displayed when you turn the camera on for the first time. This step is unnecessary in such cases.

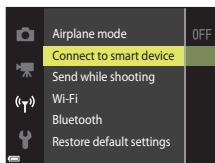

2 Camera: Press the **OK** button when the screen shown on the right is displayed.

- A dialog prompting you whether to use the NFC function is displayed. If you will use the NFC function, touch the NFC antenna of the smart device to **N** (N-mark) on the camera. When **Start pairing?** is displayed on the smart device, tap **OK** and proceed to step 7. If you will not use the NFC function, press the **OK** button.

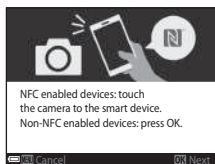
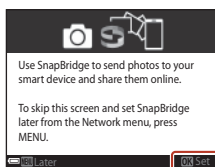

3 Camera: Confirm that the screen shown on the right is displayed.

- Prepare the smart device and proceed to the next step.

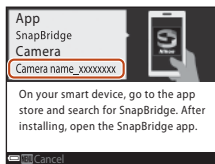

4 Smart device: Launch the SnapBridge app and tap **Pair with camera**.

- When the dialog to select a camera is displayed, tap the camera you want to connect to.
- If you did not connect to the camera by tapping **Skip** at the upper-right of the screen when launching the SnapBridge app for the first time, tap **Pair with camera** in the  tab and proceed to step 5.



5 Smart device: In the **Pair with camera** screen, tap the camera name.

- For iOS, if a dialog explaining the procedure is displayed when connecting, confirm the details and tap **Understood** (if it is not displayed, scroll down the screen). Tap the camera name again when the screen to select an accessory is displayed (it may take some time for the camera name to be displayed).

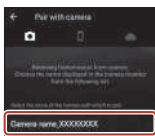

6 Camera/smart device: Confirm that the camera and smart device display the same number (six digits).

- For iOS, the number may not be displayed on the smart device depending on the OS version. Proceed to step 7 in such cases.

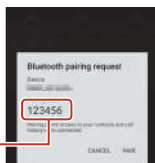
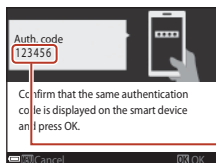

7 Camera/smart device: Press the button on the camera and tap **PAIR** in the SnapBridge app.

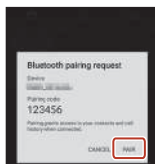



8 Camera/smart device: Finish the connection settings.

Camera: Press the **OK** button when the screen shown on the right is displayed.

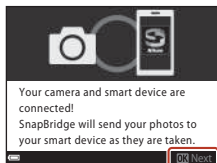
Smart device: Tap **OK** when the dialog indicating that pairing is complete is displayed.



9 Camera: Follow the on-screen instructions to complete the setup process.

- To record location data with photographs, select **Yes** when **Download location data from smart device?** is displayed. Enable the location data functions on the smart device, and enable **Synchronize location data** in the  tab → **Auto link options** in the SnapBridge app.
- You can synchronize the camera clock to the time reported by the smart device by selecting **Yes** when **Sync clock with smart device?** is displayed. Enable **Synchronize clocks** in the  tab → **Auto link options** in the SnapBridge app.

Connecting the camera and smart device is complete.

Still images captured with the camera are automatically uploaded to the smart device.

To Learn More About Using the SnapBridge App

See the online help for details on how to use the SnapBridge app (after connecting, refer to the SnapBridge app menu → **Help**).

<http://nikonimglib.com/snbr/onlinehelp/en/index.html>



If the Connection Is Unsuccessful

- If the camera displays **Could not connect.** when connecting.
 - Press the **OK** button and repeat the procedure from step 2 in "Connecting the Camera and a Smart Device" (📖23) to connect again.
 - Press the **MENU** button to cancel the connection.
- The issue may be solved by relaunching the app. Close the SnapBridge app completely and then tap the app icon again to launch it. When the app launches, repeat the procedure from step 1 in "Connecting the Camera and a Smart Device" (📖23).
- If the camera cannot connect and an error occurs in iOS, the camera may be registered as a device in iOS. Launch the iOS settings app and deregister the device (camera name) in such cases.

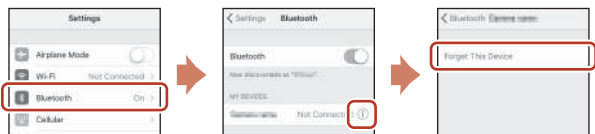

Disabling or Enabling the Wireless Connection

Use any of the following methods to disable or enable the connection.

- Switch the setting in **Network menu → Airplane mode** in the camera. You can set it to **On** to turn off all communication functions in places where wireless communication is prohibited.
- Switch the setting in **Network menu → Bluetooth → Connection** in the camera.
- Switch the setting in the  tab → **Auto link options → Auto link** in the SnapBridge app.
You can reduce battery consumption of the smart device by disabling this setting.



Image Upload and Remote Photography

Image Upload

There are three ways to upload images.

- Movies recorded with this camera cannot be uploaded.



Automatically upload images to the smart device every time they are captured. ^{1,2}	Network menu in the camera → Send while shooting → set Still images to Yes .
Select images in the camera and upload them to the smart device. ^{1,2}	Playback menu in the camera → use Mark for upload to select images.
Use the smart device to select images in the camera and download them to the smart device.	 tab in the SnapBridge app → tap Download pictures . A dialog related to Wi-Fi connections is displayed. Tap OK ³ and select images.

¹ The size of images that are uploaded is 2 megapixels.

² When **Network menu** → **Bluetooth** → **Send while off** in the camera is set to **On**, images are uploaded to the smart device automatically even when the camera is turned off.

³ Depending on the iOS version, you must select the camera SSID when you tap **OK**. See "If a Dialog Related to Wi-Fi Connections Is Displayed in iOS" (📖28) for more information.

Notes About When in a Wi-Fi Connection

- If the smart device enters sleep mode or you switch from the SnapBridge app to another app, the Wi-Fi connection will be disconnected.
- Some functions of the SnapBridge app cannot be used during a Wi-Fi connection. To cancel a Wi-Fi connection, tap the  **tab** →  → **Yes**.



Remote Photography

You can tap the  tab in the SnapBridge app → **Remote photography** to release the camera shutter using a smart device.

- Follow the instructions in the SnapBridge app to switch to a Wi-Fi connection. In iOS, a dialog related to Wi-Fi connections may be displayed. In such cases, see “If a Dialog Related to Wi-Fi Connections Is Displayed in iOS” (📖28).

If a Dialog Related to Wi-Fi Connections Is Displayed in iOS

The SnapBridge app normally connects the camera and smart device via Bluetooth. However, switch to a Wi-Fi connection when using **Download pictures** or remote photography. Depending on the iOS version, you must switch the connection manually. In such cases, use the following procedure to set the connection.

- 1** Write down the camera SSID (camera name at default) and password displayed on the screen in the smart device, and then tap **View options**.

- You can change the SSID or password by using **Network menu → Wi-Fi → Network settings** in the camera. To protect your privacy, we recommend that you change the password regularly. Disable the wireless connection when changing the password (📖26).



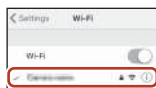

- 2** Select the SSID you wrote down in step 1 from the list of connections.

- When you establish a wireless connection for the first time, input the password you wrote down in step 1 while making sure to enter the uppercase and lowercase characters correctly. Inputting the password is unnecessary after the first time connecting.
- The Wi-Fi connection is complete when ✓ is displayed next to the camera SSID, as shown on the screen at right. Return to the SnapBridge app and operate the app.



If Images Cannot Be Uploaded Successfully



- If the connection is disconnected while uploading images through the **Send while shooting** or **Mark for upload** function in the camera, the connection and image upload may resume when you turn the camera off and then on again.
- You may be able to upload by canceling the connection and then establishing a connection again. Tap the  tab in the SnapBridge app →  → **Forget camera** → camera whose connection you want to cancel → **Yes*** to cancel the connection, and then follow the instructions in “Connecting the Camera and a Smart Device” (📖23) to establish a connection again.

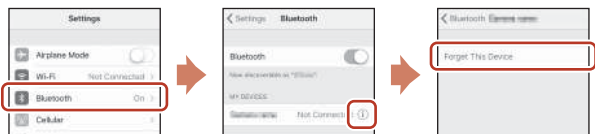

- * For iOS, a dialog about device registration will be displayed. Launch the iOS settings app and deregister the device (camera name).





✓ Notes About Image Upload and Remote Photography

- While the camera is being operated, uploading may be canceled or you may not be able to upload images or perform remote photography.
- When the settings listed below are configured on the camera, you cannot upload images or perform remote photography. Change the settings or switch to playback mode.
 - **Continuous** in  (auto) mode
 - **Sports, Panorama assist**, or **Pet portrait** (when set to  **Continuous**) in scene mode
 - **Self-Collage** or when **Blink proof** is set to **On** in smart portrait mode







Shooting Features

Selecting a Shooting Mode	31
 (Auto) Mode.....	32
 (Scene Auto Selector) Mode	34
Scene Mode (Shooting Suited to the Shooting Conditions)	35
Special Effects Mode (Applying Effects When Shooting)	42
Smart Portrait Mode (Enhancing Human Faces When Shooting)	44
Setting Shooting Functions with the Multi Selector	49
Flash Mode.....	50
Self-timer	52
Macro Mode (Taking Close-up Pictures)	54
Exposure Compensation (Adjusting Brightness).....	55
Using the Zoom	56
Focusing	57
Default Settings (Flash, Self-timer, Etc.)	61
Functions That Cannot Be Used Simultaneously When Shooting	63





Selecting a Shooting Mode



The shooting modes described below are available.

-  **Scene auto selector**
The camera automatically recognizes the shooting scene when you frame a picture, making it easier to take pictures using settings that suit the scene.
-  **Scene mode**
Camera settings are optimized according to the scene that you select.
- **S0 Special effects**
Apply effects to images during shooting.
-  **Smart portrait**
Use glamour retouch to enhance human faces during shooting, and use the smile timer or self-collage function to take pictures.
-  **Auto mode**
Used for general shooting. Settings can be changed to suit the shooting conditions and the type of shot that you want to capture.

- 1 When the shooting screen is displayed, press the  (shooting mode) button.



- 2 Use the multi selector   to select a shooting mode and press the  button.

- When scene mode or special effects mode is selected, press  to select a scene mode or effect before pressing the  button.

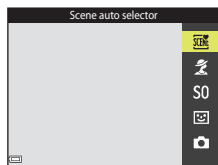

Help Display



The descriptions of functions are displayed while changing the shooting mode or while the setting screen is displayed.



You can show or hide the descriptions using **Help display** in **Monitor settings** in the setup menu.







(Auto) Mode

Used for general shooting. Settings can be adjusted to suit the shooting conditions and the type of shot you want to capture.

Enter shooting mode →  (shooting mode) button →  (auto) mode →  button



- You can change how the camera selects the area of the frame to focus on by changing the **AF area mode** setting (104). The default setting is **Target finding AF** (57).

Functions Available in (Auto) Mode

- Creative slider (32)
- Flash mode (50)
- Self-timer (52)
- Macro mode (54)
- Shooting menu (98)

Using the Creative Slider

You can adjust the brightness (exposure compensation), vividness, and hue when shooting.

Enter shooting mode →  (shooting mode) button →  (auto) mode →  button

- 1 Press the multi selector .



2 Use ◀▶ to select an item.

- **Hue**: Adjust the hue (reddish/bluish) of the entire image.
- **Vividness**: Adjust the vividness of the entire image.
- **Brightness (Exp. +/-)**: Adjust the brightness of the entire image.

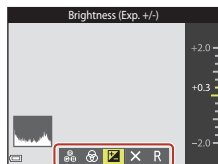

3 Use ▲▼ to adjust the level.

- You can preview the results on the screen.
- To set another item, return to step 2.
- Select **Exit** to hide the slider.
- To cancel all settings, select **R Reset** and press the **OK** button. Return to step 2 and adjust the settings again.

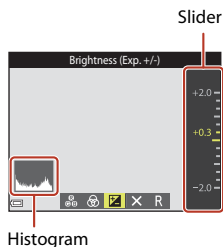

4 Press the **OK** button when setting is complete.

- The settings are applied and the camera returns to the shooting screen.



Creative Slider Settings

- This function may not be available to use in combination with other functions (📖63).
- The settings for brightness (exposure compensation), vividness and hue are saved in the camera's memory even after the camera is turned off.
- See "Using the Histogram" (📖55) for more information.













(Scene Auto Selector) Mode



The camera automatically recognizes the shooting scene when you frame a picture, making it easier to take pictures using settings that suit the scene.

Enter shooting mode →  (shooting mode) button →  (scene auto selector) mode →  button





When the camera automatically recognizes the shooting scene, the shooting mode icon displayed on the shooting screen changes accordingly.

	Portrait (for taking close-up portraits of one or two people)
	Portrait (for taking portraits of large numbers of people, or images in which the background takes up a large portion of the frame)
	Landscape
	Night portrait (for taking close-up portraits of one or two people)
	Night portrait (for taking portraits of large numbers of people, or images in which the background takes up a large portion of the frame)
	Night landscape
	Close-up
	Backlighting (for taking pictures of subjects other than people)
	Backlighting (for taking portrait pictures)
	Other scenes

Notes About (Scene Auto Selector) Mode

- Under some shooting conditions, the camera may not select the desired settings. In this case, select another shooting mode (31).
- When the digital zoom is in effect, the shooting mode icon changes to .





Functions Available in (Scene Auto Selector) Mode

- Flash mode (50)
- Self-timer (52)
- Exposure compensation (55)
- Image mode (98)



















Scene Mode (Shooting Suited to the Shooting Conditions)

When a scene is selected, camera settings are automatically optimized for the selected scene.

Enter shooting mode →  (shooting mode) button →  (second icon from the top*) →  →  → select a scene →  button

* The icon of the last scene selected is displayed.

 Portrait (default setting)	 Dusk/dawn ^{1, 2, 3}
 Landscape ^{1, 2}	 Night landscape ^{1, 2, 3} (📖36)
 Sports ² (📖36)	 Close-up (📖36)
 Night portrait ³	 Food (📖36)
 Party/indoor ² (📖36)	 Fireworks show ^{1, 3} (📖37)
 Beach ²	 Backlighting ² (📖37)
 Snow ²	 Panorama assist (📖39)
 Sunset ^{2, 3}	 Pet portrait (📖37)

¹ The camera focuses at infinity.

² The camera focuses on the area in the center of the frame.

³ Use of a tripod is recommended, because the shutter speed is slow. Set **Photo VR** (📖124) to **Off** in the setup menu when using a tripod to stabilize the camera during shooting.



Tips and Notes About Scene Mode







Sports

- While the shutter-release button is held all the way down, the camera shoots up to about 6 images continuously at a rate of about 1.1 fps (when image mode is set to **20M**).
- The frame rate for continuous shooting may vary depending on the current image mode setting, the memory card used, or shooting conditions.
- Focus, exposure, and hue are fixed at the values determined with the first image in each series.





Party/indoor

- To avoid the effects of camera shake, hold the camera steady. Set **Photo VR** (124) to **Off** in the setup menu when using a tripod to stabilize the camera during shooting.





Night landscape

- On the screen displayed when  **Night landscape** is selected, select  **Hand-held** or  **Tripod**.
-  **Hand-held** (default setting): Select this option to produce shots with reduced blurring and noise even when the camera is hand-held.
-  **Tripod**: Select this option when using a tripod or other means to stabilize the camera when shooting.
 - Vibration reduction is disabled even when **Photo VR** (124) in the setup menu is set to **On**.

Close-up

- Macro mode (54) is enabled and the camera automatically zooms to the closest position at which it can focus.
- You can move the focus area. Press the  button, use the multi selector  to move the focus area, and press the  button to apply the setting.

Food

- Macro mode (54) is enabled and the camera automatically zooms to the closest position at which it can focus.
- You can adjust hue by using the multi selector . The hue setting is saved in the camera's memory even after the camera is turned off.
- You can move the focus area. Press the  button, use the multi selector  to move the focus area, and press the  button to apply the setting.

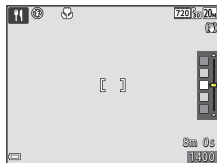





Fireworks show

- The shutter speed is fixed at four seconds.
- The zoom is restricted to four fixed positions.





Backlighting

- The flash always fires.

Pet portrait

- When you point the camera at a dog or cat, the camera detects the pet's face and focuses on it. By default, the shutter is automatically released when a dog or cat face is detected (pet portrait auto release).
- On the screen displayed when  **Pet portrait** is selected, select  **Single** or  **Continuous**.
 -  **Single**: Whenever a dog or cat face is detected, the camera captures one image.
 -  **Continuous**: Whenever a dog or cat face is detected, the camera captures three images continuously.

Pet Portrait Auto Release and Self-portrait Timer

- Press the multi selector  to change the **Pet portrait auto release** and **Self-portrait timer** settings.
 - : The camera detects a dog or cat face and automatically releases the shutter.
 -  **5s**: The camera detects a dog, cat, or human face. The shutter is automatically released 5 seconds after the shutter-release button is pressed.
 - **OFF**: The camera does not release the shutter automatically, even if a dog, cat, or human face is detected. Press the shutter-release button.
- **Pet portrait auto release** is set to **OFF** after five bursts have been taken.
- Shooting is also possible by pressing the shutter-release button, regardless of the **Pet portrait auto release** setting. When  **Continuous** is selected, you can take pictures continuously while holding down the shutter-release button all the way.



✓ Focus Area

- When the camera detects a face, the face is displayed inside a yellow border. When the camera acquires focus on a face displayed inside a double border (focus area), the double border changes to green. If no faces are detected, the camera focuses on the subject in the center of the frame.
- Under some shooting conditions, the pet face may not be detected and other subjects may be displayed inside a border.

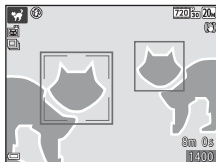

Using Skin Softening

When the shutter is released while using one of the shooting modes listed below, the camera detects human faces and processes the image to soften facial skin tones (up to three faces).

- Smart portrait mode (📖44)
 - The amount of the **Skin softening** effect can be adjusted.
- **SCN** (scene auto selector) mode (📖34)
- **Portrait** or **Night portrait** scene mode (📖35)

Editing functions such as **Skin softening** can be applied to saved images by using **Glamour retouch** (📖71) even after shooting.

✓ Notes About Skin Softening

- It may take more time than usual to save images after shooting.
- Under some shooting conditions, the desired skin softening results may not be achieved, and skin softening may be applied to areas of the image where there are no faces.



Shooting with Panorama Assist

The use of a tripod makes it easier to frame a picture. When using a tripod to stabilize the camera during shooting, set **Photo VR** (📖124) to **Off** in the setup menu.

Enter shooting mode → 📷 (shooting mode) button → 📷 (second icon from the top*) → ▶ → ▲▼ → 📷 (Panorama assist) → OK button

* The icon of the last scene selected is displayed.

1 Use the multi selector ◀▶ to select the direction in which images are joined, and press the OK button.

- If necessary, apply flash mode (📖50), self-timer (📖52), macro mode (📖54) and exposure compensation (📖55) settings in this step.
- Press the OK button to reselect the direction.



2 Frame the first portion of the panorama scene and take the first picture.

- The camera focuses on the subject in the center of the frame.
- About one third of the image is displayed as translucent.
- To cancel shooting, press the OK button.



3 Take the next picture.

- Match the outline of the next image so that one third of the frame overlaps the previous image, and press the shutter-release button.



4 Press the **OK** button when shooting is complete.

- The camera returns to step 1.



✓ Notes About Panorama Assist

- Up to three images can be taken and combined in a panorama series. Shooting automatically ends after the third image is taken.
- A panorama image may not be saved if the translucent portion of an image is not properly aligned with the subject when taking the next image.
- The range of the image seen in the saved image is narrower than that seen on the screen at the time of shooting.
- If shooting ends after only the first image is taken, the camera cannot scroll the playback of the image (📖41).
- Shooting for the panorama series is terminated if the auto off function (📖126) initiates standby mode during shooting. Setting the time allowed to elapse before the auto off function is enabled to a longer setting is recommended.
- Images cannot be deleted while shooting in panorama assist mode. When shooting a new image, return to step 1 and start over again.

📎 AE/AF-L Indicator

In panorama assist scene mode, exposure, white balance, and focus for all images in a panorama are fixed at the values for the first image in each series.

When the first image is taken, **AE/AF-L** is displayed to indicate that exposure, white balance, and focus are locked.

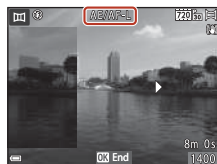

Playback with Panorama Assist

Switch to playback mode (📖18), display an image captured using panorama assist in full-frame playback mode, and then press the **OK** button to scroll the image in the direction that was used when shooting.

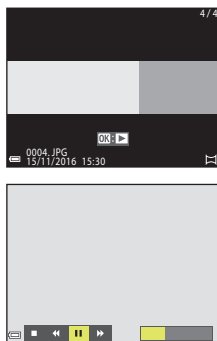

Playback controls are displayed on the screen during playback.

Use the multi selector **◀▶** to select a control, and then press the **OK** button to perform the operations described below.

Function	Icon	Description	
Rewind	◀◀	Hold down the OK button to scroll backward quickly.	
Advance	▶▶	Hold down the OK button to scroll forward quickly.	
Pause	⏸	Pause playback. The operations listed below can be performed while paused.	
		◀◀	Hold down the OK button to rewind.
		▶▶	Hold down the OK button to scroll.
		▶	Resume automatic scrolling.
End	■	Switch to full-frame playback mode.	

✓ Notes About Panorama Assist Images

- The images cannot be edited on this camera.
- This camera may not be able to scroll the playback of, or zoom in on, panorama assist images captured with another make or model of digital camera.





✓ Notes About Printing Panorama Images

The entire image may not be able to be printed depending on the printer's settings. Additionally, printing may not be possible depending on the printer.











Special Effects Mode (Applying Effects When Shooting)

Apply effects to images during shooting.

Enter shooting mode →  (shooting mode) button → S0 (third icon from the top*) →  →  → select an effect →  button

* The icon of the last effect selected is displayed.

Type	Description
S0 Soft (default setting)	Softens the image by adding a slight blur to the entire image.
SE Nostalgic sepia	Adds a sepia tone and reduces the contrast to simulate the qualities of an old photograph.
 High-contrast monochrome	Changes the image to black and white and gives it sharp contrast.
 Selective color	Creates a black and white image in which only the specified color remains.
POP Pop	Increases the color saturation of the entire image to create a bright look.
 Cross process	Gives the image a mysterious appearance based on a specific color.
 Toy camera effect 1	Gives the entire image a yellowish hue and darkens the image periphery.
 Toy camera effect 2	Decreases the color saturation of the entire image and darkens the image periphery.
 Mirror	Creates a bilaterally symmetric image whose right half is an inverted mirror image of the left half.

- The camera focuses on the area in the center of the frame.
- When **Selective color** or **Cross process** is selected, use the multi selector  to select the desired color, and press the  button to apply the color. To change the color selection, press the  button again.





Functions Available in Special Effects Mode

- Flash mode (📖50)
- Self-timer (📖52)
- Macro mode (📖54)
- Exposure compensation (📖55)
- Image mode (📖98)



Smart Portrait Mode (Enhancing Human Faces When Shooting)











You can take a picture with the glamour retouch function to enhance human faces.

Enter shooting mode →  (shooting mode) button →  Smart portrait mode →  button

1 Press the multi selector .



2 Apply an effect.

- Use   to select the desired effect.
- Use   to select the amount of effect.
- You can simultaneously apply multiple effects.
 **Skin softening**,  **Foundation makeup**,  **Soft**,  **Vividness**,  **Brightness (Exp. +/-)**
- Select  **Exit** to hide the slider.
- After configuring the desired effects, press the  button to apply them.

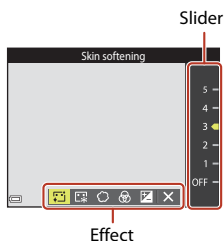

3 Frame the picture and press the shutter-release button.

Notes About Smart Portrait Mode

The amount of effect may differ between the image on the shooting screen and the saved image.









Functions Available in Smart Portrait Mode

- Glamour retouch (📖44)
- Smile timer (📖46)
- Self-Collage (📖47)
- Flash mode (📖50)
- Self-timer (📖52)
- Smart portrait menu (📖108)



Using Smile Timer

Enter shooting mode →  (shooting mode) button →  Smart portrait mode
→  button

When you press the multi selector  to select 
Smile timer and press the  button, the camera automatically releases the shutter whenever a smiling face is detected.

- Set the glamour retouch function before selecting smile timer (44).
- When you press the shutter-release button to take a picture, smile timer is terminated.

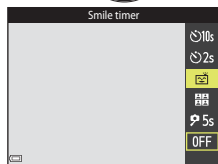

Notes About Smile Timer

Under some shooting conditions, the camera may be unable to detect faces or smiles (58). The shutter-release button can also be used for shooting.

When the Self-timer Lamp Flashes



When using smile timer, the self-timer lamp flashes when the camera detects a face and flashes quickly immediately after the shutter is released.



Using Self-Collage

The camera can capture a series of four or nine images at intervals and save them as a one-frame image (a collage image).



Enter shooting mode →  (shooting mode) button →  Smart portrait mode →  button

1 Press the multi selector to select **Self-Collage**, and press the button.

- A confirmation dialog is displayed.
- When you press the **MENU** button and select **Self-Collage** before pressing , you can configure the settings for **Number of shots**, **Interval**, and **Shutter sound** (📖108).
- If you want to apply glamour retouch when shooting, set the effect before selecting self-collage (📖44).

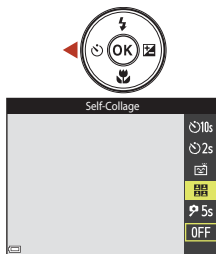

2 Take a picture.

- When you press the shutter-release button, a countdown starts (about five seconds) and the shutter is automatically released.
- The camera automatically releases the shutter for the remaining pictures. A countdown starts about three seconds before shooting.
- The number of shots is indicated by  on the screen. It is displayed in green during shooting and it changes to white after shooting.

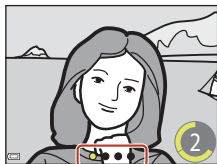

3 Select **Yes** and press the button.

- The collage image is saved.
- Each captured image is saved as an individual image separate from the collage image.

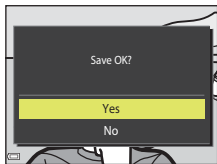

Notes About Self-Collage

- If you press the shutter-release button before the camera captures the specified number of shots, shooting is canceled and the collage image is not saved. The pictures that were taken before shooting was canceled are saved as individual images.
- This function may not be available to use in combination with other functions (63).



Setting Shooting Functions with the Multi Selector

When the shooting screen is displayed, you can press the multi selector ▲ (⚡) ◀ (⌚) ▼ (🌸) ▶ (📷) to set the functions described below.



- **⚡ Flash mode**
You can select a flash mode to match the shooting conditions.
- **⌚ Self-timer**
The camera releases the shutter 10, 2, or 5 seconds after you press the shutter-release button.
- **🌸 Macro mode**
Use macro mode when you take close-up pictures.
- **📷 Exposure compensation**
You can adjust overall image brightness.

The functions that can be set vary depending on the shooting mode.



Flash Mode

You can select a flash mode to match the shooting conditions.

- 1 Press the multi selector ▲ (⚡).



- 2 Select the desired flash mode (📖51) and press the OK button.

- If the OK button is not pressed, the selection will be canceled.



The Flash Lamp

- The status of the flash can be confirmed by pressing the shutter-release button halfway.
 - On: The flash fires when you press the shutter-release button all the way down.
 - Flashing: The flash is charging. The camera cannot shoot images.
 - Off: The flash does not fire when a picture is taken.
- If the battery level is low, the screen turns off while the flash is charging.

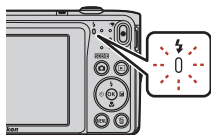

Available Flash Modes

AUTO Auto

The flash fires when necessary, such as in dim lighting.

- The flash mode indicator is only displayed immediately after setting on the shooting screen.

Auto with red-eye reduction

Reduce red-eye in portraits caused by the flash.

Off

The flash does not fire.

- We recommend using a tripod to stabilize the camera when shooting in dark surroundings.

Fill flash

The flash fires whenever a picture is taken. Use to “fill-in” (illuminate) shadows and backlit subjects.

SLOW Slow sync

Suited to evening and night portraits that include background scenery. Fill flash fires to illuminate the main subject; slow shutter speeds are used to capture background at night or under dim lighting.

Notes About Using the Flash

If you use the flash while the zoom is at the wide-angle position, the image periphery may appear dark depending on the distance to the subject.

Try moving the zoom slightly toward telephoto to correct the problem.

The Flash Mode Setting

- The setting may not be available with some shooting modes (61).
- The setting applied in  (auto) mode is saved in the camera’s memory even after the camera is turned off.

Red-eye Reduction

If the camera detects red eye while saving an image, the affected area is processed to reduce red-eye before the image is saved.

Note the following when shooting:

- More time than usual is required to save images.
- Red-eye reduction may not produce the desired results in some situations.
- In rare cases, red-eye reduction may be applied unnecessarily to other areas of the image. In these cases, select another flash mode and take the picture again.



Self-timer

The camera is equipped with a self-timer that releases the shutter 10, 2, or 5 seconds after you press the shutter-release button.

Set **Photo VR** (📖124) to **Off** in the setup menu when using a tripod to stabilize the camera during shooting.

1 Press the multi selector ◀ (🕒).



2 Select 🕒10s, 🕒2s, or 🕒5s, and press the OK button.

- 🕒10s (10 seconds): Use on important occasions, such as weddings.
- 🕒2s (2 seconds): Use to prevent camera shake.
- 🕒5s (5 seconds): Use to take self-portraits (self-portrait timer).
- If the OK button is not pressed, the selection will be canceled.
- When the shooting mode is **Pet portrait** scene mode, 🐾 (pet portrait auto release) and 🕒5s (self-portrait timer) are displayed (📖37). 🕒10s and 🕒2s cannot be used.
- When the shooting mode is smart portrait mode, you can also use 📷 **Smile timer** (📖46), 📷 **Self-Collage** (📖47) or 🕒5s **Self-portrait timer** in addition to 🕒10s and 🕒2s.

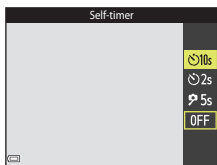

3 Frame the picture and press the shutter-release button halfway.

- Focus and exposure are set.



4 Press the shutter-release button all the way down.

- Countdown starts. The self-timer lamp flashes and then glows steadily about one second before the shutter is released.
- When the shutter is released, the self-timer is set to **OFF**.
- To stop the countdown, press the shutter-release button again.

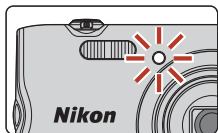

Macro Mode (Taking Close-up Pictures)

Use macro mode when taking close-up pictures.

- 1 Press the multi selector ▼ (🌿).



- 2 Select **ON** and press the (OK) button.

- If the (OK) button is not pressed, the selection will be canceled.

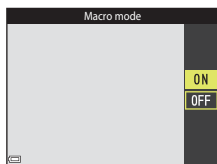

- 3 Move the zoom control to set the zoom ratio to a position where 🌿 and the zoom indicator are displayed in green.



- When the zoom ratio is set to a position where the zoom indicator is displayed in green, the camera can focus on subjects as close as approximately 9 cm (3.6 in.) from the lens.
When the zoom is at the position where 🏠 is displayed, the camera can focus on subjects as close as approximately 2 cm (0.8 in.) from the lens.

The Macro Mode Setting

- The setting may not be available with some shooting modes (📖61).
- If the setting is applied in 📷 (auto) mode, it will remain saved in the camera's memory even after the camera is turned off.



Exposure Compensation (Adjusting Brightness)

You can adjust overall image brightness.

- 1 Press the multi selector ► (Z).



- 2 Select a compensation value and press the OK button.

- To brighten the image, set a positive (+) value.
- To darken the image, set a negative (-) value.
- The compensation value is applied, even without pressing the OK button.
- When the shooting mode is smart portrait mode, the glamour retouch screen is displayed instead of the exposure compensation screen (44).
- When the shooting mode is (auto) mode, the creative slider is displayed instead of the exposure compensation screen (32).

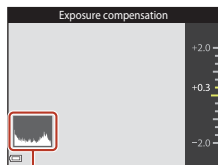

Histogram

Exposure Compensation Value

- The setting may not be available with some shooting modes (61).
- If the setting is applied in (auto) mode, it will remain saved in the camera's memory even after the camera is turned off.

Using the Histogram

A histogram is a graph showing the distribution of tones in the image. Use as a guide when using exposure compensation and shooting without the flash.

- The horizontal axis corresponds to pixel brightness, with dark tones to the left and bright tones to the right. The vertical axis shows the number of pixels.
- Increasing the exposure compensation value shifts tone distribution to the right, and decreasing it shifts tone distribution to the left.



Using the Zoom

When you move the zoom control, the zoom lens position changes.

- To zoom in: Move toward **T**
- To zoom out: Move toward **W**

When you turn the camera on, the zoom moves to the maximum wide-angle position.

- A zoom indicator is displayed on the shooting screen when the zoom control is moved.
- Digital zoom, which allows you to further magnify the subject up to approximately 4x the maximum optical zoom ratio, can be activated by moving and holding the zoom control toward **T** when the camera is zoomed in to the maximum optical zoom position.

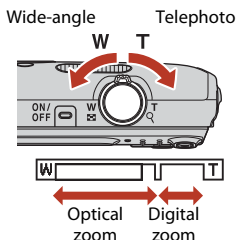

Digital Zoom

The zoom indicator changes to blue when the digital zoom is activated, and it changes to yellow when the zoom magnification is increased further.



- Zoom indicator is blue: Image quality is not noticeably reduced by using the Dynamic Fine Zoom.
- Zoom indicator is yellow: There may be cases in which image quality is noticeably reduced.
- The indicator remains blue across a wider area when the image size is smaller.
- The zoom indicator may not change to blue when using certain continuous shooting settings or other settings.



Focusing

The focus area varies depending on the shooting mode.

The Shutter-release Button

<p>Press halfway</p> 	<p>To set focus and exposure (shutter speed and F-number), press the shutter-release button lightly until you feel a slight resistance. Focus and exposure remain locked while the shutter-release button is pressed halfway.</p>
<p>Press all the way</p> 	<p>Press the shutter-release button all the way to release the shutter and take a picture. Do not use force when pressing the shutter-release button, as this may result in camera shake and blurred images. Press the button gently.</p>

Using Target Finding AF

When **AF area mode** (📖104) in 📷 (auto) mode is set to **Target finding AF**, the camera focuses in the manner described below when you press the shutter-release button halfway.

- The camera detects the main subject and focuses on it. When the subject is in focus, the focus area is displayed in green. If a human face is detected, the camera automatically sets focus priority on it.

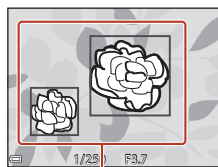

Focus areas

- If no main subject is detected, the camera automatically selects one or more of the nine focus areas containing the subject closest to the camera. When the subject is in focus, the focus areas that are in focus are displayed in green.

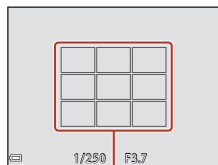

Focus areas



✓ Notes About Target Finding AF

- Depending on shooting conditions, the subject that the camera determines to be the main subject may vary.
- The main subject may not be detected when using certain **White balance** settings.
- The camera may not detect the main subject appropriately in the following situations:
 - When the subject is very dark or bright
 - When the main subject lacks clearly defined colors
 - When the shot is framed so that the main subject is at the edge of the screen
 - When the main subject is composed of a repeating pattern

Using Face Detection

In the following shooting modes, the camera uses face detection to automatically focus on human faces.

- **Portrait**, **Night portrait**, or **Backlighting** in **SCN** (scene auto selector) mode (📖34)
- **Portrait** or **Night portrait** scene mode (📖35)
- Smart portrait mode (📖44)
- When **AF area mode** (📖104) in **☑** (auto) mode (📖32) is set to **Face priority**.

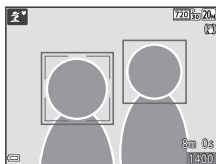

If the camera detects more than one face, a double border is displayed around the face that the camera focuses on, and single borders are displayed around the other faces.

If the shutter button is pressed halfway when no faces are detected:

- In **SCN** (scene auto selector) mode, the focus area changes depending on the scene.
- In **Portrait** and **Night portrait** scene modes or in smart portrait mode, the camera focuses in the center of the frame.
- In **☑** (auto) mode, the camera selects the focus area containing the subject closest to the camera.

✓ Notes About Face Detection

- The camera's ability to detect faces depends on a variety of factors, including the direction in which the faces are looking.
- The camera cannot detect faces in the following situations:
 - When faces are partially hidden by sunglasses or otherwise obstructed
 - When faces take up too much or too little of the frame



Subjects Not Suitable for Autofocus

The camera may not focus as expected in the following situations. In rare cases, the subject may not be in focus despite the fact that the focus area or the focus indicator is displayed in green:

- Subject is very dark
- Objects of sharply differing brightness are included in the shooting conditions (e.g. the sun behind the subject makes that subject appear very dark)
- No contrast between the subject and surroundings (e.g. a portrait subject wearing a white shirt is standing in front of a white wall)
- Several objects are at different distances from the camera (e.g. the subject is inside a cage)
- Subjects with repeating patterns (window blinds, buildings with multiple rows of similarly shaped windows, etc.)
- Subject is moving rapidly

In the situations noted above, try pressing the shutter-release button halfway to refocus several times, or focus on another subject positioned at the same distance from the camera as the actual desired subject, and use focus lock ()60).



Focus Lock

Focus lock shooting is recommended when the camera does not activate the focus area that contains the desired subject.

1 Set **AF area mode to Center** in  (auto) mode ( 104).

2 Position the subject in the center of the frame and press the shutter-release button halfway.

- The camera focuses on the subject and the focus area is displayed in green.
- Exposure is also locked.

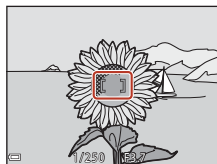

3 Without lifting your finger, recompose the picture.

- Make sure to maintain the same distance between the camera and the subject.

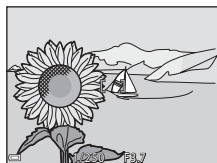









































4 Press the shutter-release button all the way down to take the picture.



Default Settings (Flash, Self-timer, Etc.)

Default settings for each shooting mode are listed below.

	Flash ( 50)	Self-timer ( 52)	Macro ( 54)	Exposure compensation ( 55)
 (scene auto selector)	 AUTO ¹	Off	Off ²	0.0
 (scene)				
 (portrait)		Off	Off ³	0.0
 (landscape)	 ³	Off	Off ³	0.0
 (sports)	 ³	Off ³	Off ³	0.0
 (night portrait)	 ⁴	Off	Off ³	0.0
 (party/indoor)	 ⁵	Off	Off ³	0.0
 (beach)	 AUTO	Off	Off ³	0.0
 (snow)	 AUTO	Off	Off ³	0.0
 (sunset)	 ³	Off	Off ³	0.0
 (dusk/dawn)	 ³	Off	Off ³	0.0
 (night landscape)	 ³	Off	Off ³	0.0
 (close-up)	 ³	Off	On ³	0.0
 (food)	 ³	Off	On ³	0.0
 (fireworks show)	 ³	Off ³	Off ³	0.0 ³
 (backlighting)	 ³	Off	Off ³	0.0
 (panorama assist)	 ³	Off	Off	0.0
 (pet portrait)	 ³	 ⁶	Off	0.0



	Flash (📖50)	Self-timer (📖52)	Macro (📖54)	Exposure compensation (📖55)
🎭 (special effects)	🚫	Off	Off	0.0
😊 (smart portrait)	⚡AUTO	Off ⁷	Off ³	– ⁸
📷 (auto)	⚡AUTO	Off	Off	– ⁹

- ¹ The camera automatically selects the flash mode appropriate for the scene it has selected. 🚫 (off) can be selected manually.
- ² Cannot be changed. The camera enters macro mode when 🎭 is selected.
- ³ Cannot be changed.
- ⁴ Cannot be changed. The flash mode setting is fixed at fill flash with red-eye reduction.
- ⁵ May switch to slow sync with red-eye reduction flash mode.
- ⁶ The 🕒10s and 🕒2s self-timer cannot be used. Pet portrait auto release (📖37) and self-portrait timer (📖37) can be turned on or off.
- ⁷ 📷 Smile timer (📖46), 📷 Self-Collage (📖47), or 🕒5s Self-portrait timer can be used in addition to the 🕒10s and 🕒2s self-timer.
- ⁸ The glamour retouch screen is displayed (📖44).
- ⁹ Creative slider is displayed (📖32).



Functions That Cannot Be Used Simultaneously When Shooting

Some functions cannot be used with other menu options.

Restricted function	Option	Description
Flash mode	Continuous (📖102)	When Continuous is selected, the flash cannot be used.
	Blink proof (📖109)	When Blink proof is set to On , the flash cannot be used.
Self-timer	AF area mode (📖104)	When Subject tracking is selected, the self-timer cannot be used.
Macro mode	AF area mode (📖104)	When Subject tracking is selected, macro mode cannot be used.
Image mode	ISO sensitivity (📖103)	When 3200 is selected, the image mode setting of only 4M 2272×1704 , 2M 1600×1200 , or VGA 640×480 can be selected. If any image mode setting other than above is selected, the image mode setting is automatically changed to 4M 2272×1704 when ISO sensitivity is set to 3200 .
White balance	Hue (Using the creative Slider) (📖32)	When Hue is adjusted using the creative slider, White balance setting is not available in the shooting menu.
AF area mode	Digital zoom (📖125)	When digital zoom is in effect, the camera focuses in the center of the frame regardless of the AF area mode setting.
Blink proof	Self-Collage (📖47)	When Self-Collage is set, Blink proof is disabled.
Digital zoom	AF area mode (📖104)	When Subject tracking is selected, digital zoom cannot be used.

✓ Notes About Digital Zoom

- Depending on the shooting mode or the current settings, digital zoom may not be available (📖125).
- When digital zoom is in effect, the camera focuses in the center of the frame.



Playback Features

Playback Zoom.....	65
Thumbnail Playback/Calendar Display.....	66
List by Date Mode	67
Editing Images (Still Images).....	68



Playback Zoom

Moving the zoom control toward **T** (Q playback zoom) in full-frame playback mode (📖18) zooms in on the image.

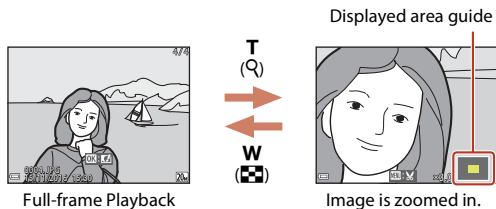

- You can change the magnification rate by moving the zoom control toward **W** (📐) or **T** (Q).
- To view a different area of the image, press the multi selector ▲▼◀▶.
- When a zoomed image is displayed, press the **OK** button to return to full-frame playback mode.

Cropping Images

When a zoomed image is displayed, you can press the **MENU** button to crop the image to include only the visible portion and save it as a separate file (📖74).



Thumbnail Playback/Calendar Display

Moving the zoom control toward **W** (🗪 thumbnail playback) in full-frame playback mode (📖18) displays images as thumbnails.







- You can change the number of thumbnails displayed by moving the zoom control toward **W** (🗪) or **T** (🕒).
- While using thumbnail playback mode, press the multi selector ▲▼◀▶ to select an image and then press the **OK** button to display that image in full-frame playback mode.
- While using calendar display mode, press ▲▼◀▶ to select a date and then press the **OK** button to display the images captured on that day.

✓ Notes About Calendar Display



Images captured when the camera's date is not set are treated as images captured on January 1, 2016.







List by Date Mode

Press the  button (playback mode) →  button →  List by date →  button

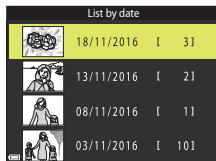
Use the multi selector ▲▼ to select a date and then press the  button to play back the images captured on the selected date.

- Functions in the playback menu ( 110) can be used for the images in the selected shooting date (except **Copy**).
- The following operations are available while the shooting date selection screen is displayed.
 - **MENU** button: The functions listed below are available.
 - Slide show
 - Protect*
 - * The same settings can be applied to all images captured on the selected date.
 -  button: Deletes all images captured on the selected date.



List by date		
	18/11/2016	[3]
	13/11/2016	[2]
	08/11/2016	[1]
	03/11/2016	[10]

Notes About List by Date Mode

- Up to the most recent 29 dates can be selected. If images exist for more than 29 dates, all images saved earlier than the most recent 29 dates will be combined under **Others**.
- The 9,000 most recent images can be displayed.
- Images captured when the camera's date is not set are treated as images captured on January 1, 2016.



Editing Images (Still Images)

Before Editing Images

You can easily edit images on this camera. Edited copies are saved as separate files. Edited copies are saved with the same shooting date and time as the original.

Restrictions on Image Editing

- An image can be edited up to 10 times.
- You may not be able to edit images of a certain size or with certain editing functions.

Quick Effects: Changing Hue or Mood

Process images with a variety of effects.

Painting, Photo illustration, Soft portrait, Portrait (color + B&W), Fisheye, Cross screen, or **Miniature effect** can be selected.

- 1 Display the image to which you want to apply an effect in full-frame playback mode and press the **OK** button.



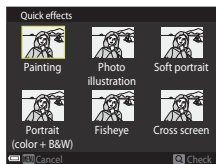

- 2 Use the multi selector **▲▼◀▶** to select the desired effect and press the **OK** button.
 - Move the zoom control (**Ⓜ**) toward **T** (**🔍**) to switch to full-frame playback or **W** (**📄**) to switch to thumbnail playback.
 - To exit without saving the edited image, press the **MENU** button.



- 3 Select **Yes** and press the **OK** button.
 - An edited copy is created.



Quick Retouch: Enhancing Contrast and Saturation



Press the  button (playback mode) → select an image → MENU button → Quick retouch →  button

Use the multi selector ▲▼ to select the amount of effect applied and press the  button.

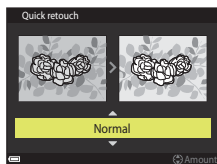
- The edited version is displayed on the right.
- To exit without saving the copy, press ◀.



D-Lighting: Enhancing Brightness and Contrast



Press the  button (playback mode) → select an image → MENU button → D-Lighting →  button

Use the multi selector ▲▼ to select **OK** and press the  button.

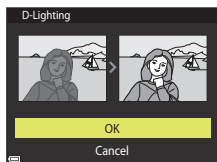
- The edited version is displayed on the right.
- To exit without saving the copy, select **Cancel** and press the  button.



Red-eye Correction: Correcting Red-eye When Shooting with the Flash

Press the  button (playback mode) → select an image → MENU button → Red-eye correction →  button

Preview the result and press the  button.

- To exit without saving the copy, press the multi selector 

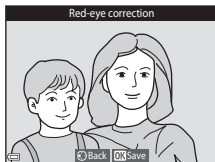







Notes About Red-eye Correction

- Red-eye correction can only be applied to images when red-eye is detected.
- Red-eye correction can be applied to pets (dogs or cats) even if their eyes are not red.
- Red-eye correction may not produce the desired results in some images.
- In rare cases, red-eye correction may be applied unnecessarily to other areas of the image.









Glamour Retouch: Enhancing Human Faces

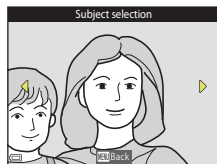











Press the  button (playback mode) → select an image → MENU button → Glamour retouch →  button

1 Use the multi selector     to select the face that you want to retouch and press the  button.

- When only one face is detected, proceed to step 2.



2 Use   to select the effect, use   to select the effect level, and press the  button.

- You can simultaneously apply multiple effects. Adjust or check the settings for all effects before pressing the  button.
 (Small face),  (Skin softening),  (Foundation makeup),  (Glare reduction),  (Hide eye bags),  (Big eyes),  (Whiten eyes),  (Eye shadow),  (Mascara),  (Whiten teeth),  (Lipstick),  (Redden cheeks)
- Press the MENU button to return to the screen for selecting a person.

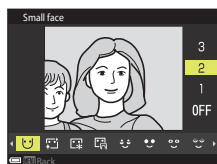

3 Preview the result and press the  button.

- To change the settings, press  to return to step 2.
- To exit without saving the edited image, press the MENU button.

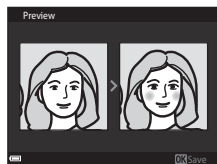

4 Select **Yes** and press the **OK** button.

- An edited copy is created.

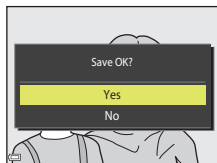





✓ **Notes About Glamour Retouch**



- Only one face at a time can be edited. To retouch another face in the same image, select the edited copy of the image and make additional changes.
- Depending on the direction in which faces are looking, or the brightness of faces, the camera may be unable to accurately detect faces, or the glamour retouch function may not perform as expected.
- If no faces are detected, a warning is displayed and the screen returns to the playback menu.
- The glamour retouch function is available only for images captured at an ISO sensitivity of 1600 or lower, and the image size of 640 × 480 or larger.





Small Picture: Reducing the Size of an Image

Press the  button (playback mode) → select an image → MENU button → Small picture →  button

1 Use the multi selector   to select the desired copy size and press the  button.

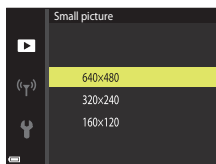
- Images captured at an image mode setting of  are saved at a size of 640 × 360, and images captured at an image mode setting of  are saved at 480 × 480. Press the  button to proceed to step 2.



2 Select **Yes** and press the  button.

- An edited copy is created (compression ratio of approximately 1:8).

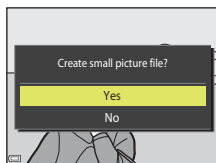

Crop: Creating a Cropped Copy

1 Move the zoom control to enlarge the image (📖65).

2 Adjust the image so that only the portion that you want to keep is displayed, and then press the **MENU** (menu) button.

- Move the zoom control toward **T** (🔍) or **W** (📐) to adjust the magnification rate. Set a magnification rate at which **MENU** : ✂️ is displayed.
- Use the multi selector ▲▼◀▶ to scroll to the portion of the image that you want to display.



3 Check that the desired cropping area is displayed, and then press the **OK** button.

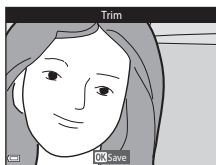

4 Select **Yes** and press the **OK** button.

- An edited copy is created.



Image Size

- The aspect ratio (horizontal and vertical ratio) of a cropped image is the same as that of the original image.
- An image that is cropped to a size of 320 × 240 or smaller is displayed at a small size on the playback screen.



Movies

Basic Operations of Movie Recording and Movie Playback.....	76
Operations During Movie Playback.....	79



Basic Operations of Movie Recording and Movie Playback

1 Display the shooting screen.

- Check the remaining amount of movie recording time.

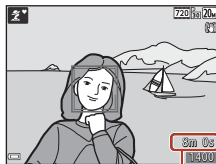

Remaining movie recording time

2 Press the movie-record) button to start movie recording.

- The camera focuses on the subject in the center of the frame.

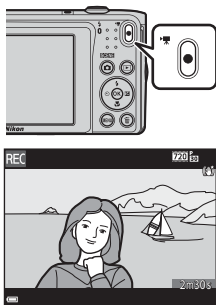

3 Press the movie-record) button again to end recording.

4 Select a movie in full-frame playback mode and press the button to play it back.

- An image with a movie options icon is a movie.



Movie options



Movie Frame

- The area that is captured in a movie varies depending on the **Movie options** settings in the movie menu.
- If **Photo info** in **Monitor settings** (📖121) in the setup menu is set to **Movie frame+auto info**, you can confirm the area that will be captured in a movie before you start recording.

Maximum Movie Recording Time

Individual movie files cannot exceed 2 GB in size or 29 minutes in length, even when there is sufficient free space on the memory card for longer recording.

- The remaining recording time for a single movie is displayed on the shooting screen.
- The actual remaining recording time may vary depending on the movie content, subject movement, or type of memory card.
- Memory cards with an SD Speed Class rating of 6 or faster are recommended when recording movies (📖163). Movie recording may stop unexpectedly when a memory card with a lower Speed Class rating is used.

✔ Camera Temperature

- The camera may become hot when shooting movies for an extended period of time or when the camera is used in a hot area.
- If the inside of the camera becomes extremely hot when recording movies, the camera will automatically stop recording.
The amount of time remaining until the camera stops recording (🕒10s) is displayed. After the camera stops recording, it turns itself off.
Leave the camera off until the inside of the camera has cooled.



Notes About Movie Recording

✔ Notes About Saving Images or Movies

The indicator showing the number of exposures remaining or the indicator showing the remaining recording time flashes while images or movies are being saved. **Do not open the battery-chamber/memory card slot cover or remove the battery or memory card** while an indicator is flashing. Doing this could result in loss of data, or in damage to the camera or the memory card.

✔ Notes About Recorded Movies

- There may be some degradation in image quality when digital zoom is used.
- The sounds of zoom control operation, zoom, autofocus lens drive movement, movie vibration reduction, and aperture operation when brightness changes may be recorded.
- Smear (📖140) visible on the screen with movie recording will be recorded with movies. Avoiding bright objects such as the sun, reflections of the sun, and electric lights when recording movies is recommended.
- Depending on the distance to the subject or the amount of zoom applied, colored stripes may appear on subjects with repeating patterns (fabrics, lattice windows, etc.) during movie recording and playback. This occurs when the pattern in the subject and the layout of the image sensor interfere with each other; it is not a malfunction.

✔ Notes About Vibration Reduction During Movie Recording

- When **Movie VR** (📖116) in the movie menu is set to **On (hybrid)**, the angle of view (i.e., the area visible in the frame) becomes narrower during movie recording.
- When using a tripod to stabilize the camera during shooting, set **Movie VR** to **Off** to prevent potential errors caused by this function.

✔ Notes About Autofocus for Movie Recording

Autofocus may not perform as expected (📖59). Should this occur, try the following:

1. Set **Autofocus mode** in the movie menu to **Single AF** (default setting) before starting movie recording.
2. Frame another subject (positioned at the same distance from the camera as the intended subject) in the center of the frame, press the ● (📹 movie-record) button to start recording, and modify the composition.



Operations During Movie Playback

To adjust the volume, move the zoom control while a movie is playing (📖2).

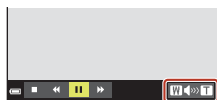

Volume indicator

Playback controls are displayed on the screen. The operations described below can be performed by using the multi selector ◀▶ to select a control and then pressing the Ⓚ button.



When paused

Function	Icon	Description	
Rewind	◀◀	Hold down the Ⓚ button to rewind the movie.	
Fast-forward	▶▶	Hold down the Ⓚ button to fast-forward the movie.	
Pause	⏸	Pause playback. The operations listed below can be performed while paused.	
		◀◀	Rewind the movie one frame. Hold down the Ⓚ button for continuous rewinding.
		▶▶	Advance the movie one frame. Hold down the Ⓚ button for continuous advancing.
	▶	Resume playback.	
End	■	Return to full-frame playback mode.	



Connecting the Camera to a TV, Printer, or Computer

Utilizing Images	81
Viewing Images on a TV	82
Printing Images Without a Computer	83
Transferring Images to a Computer (ViewNX-i)	87



Utilizing Images

In addition to using the SnapBridge app to enjoy the captured images, you can also utilize the images in various ways by connecting the camera to the devices described below.

Viewing Images on a TV



Images and movies captured with the camera can be viewed on a TV. Connection method: Connect the video and audio plugs of an optional audio video cable to the TV's input jacks.

Printing Images Without Using a Computer



If you connect the camera to a PictBridge-compatible printer, you can print images without using a computer. Connection method: Connect the camera directly to the printer's USB port with the USB cable.

Transferring Images to a Computer (ViewNX-i)



You can transfer images and movies to a computer for viewing and editing. Connection method: Connect the camera to the computer's USB port with the USB cable.

- Before connecting to a computer, install ViewNX-i on the computer.

✓ Notes About Connecting Cables to the Camera

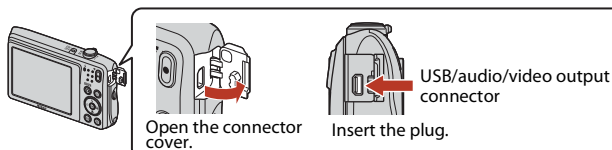

- Make sure to turn the camera off before connecting or disconnecting cables. Check the shape and direction of the plugs and do not insert or remove the plugs at an angle.
- Make sure that the camera battery is sufficiently charged. If the EH-62G AC Adapter (available separately) is used, this camera can be powered from an electrical outlet. Do not, under any circumstances, use an AC adapter other than the EH-62G. Failure to observe this precaution could result in overheating or damage to the camera.
- For information about the connection methods and subsequent operations, refer to the documentation included with the device in addition to this document.



Viewing Images on a TV

1 Turn off the camera and connect it to the TV.

- Connect the yellow plug to the video-in jack and the white plug to the audio-in jack on the TV.
- Check the shape and direction of the plugs and do not insert or remove the plugs at an angle.

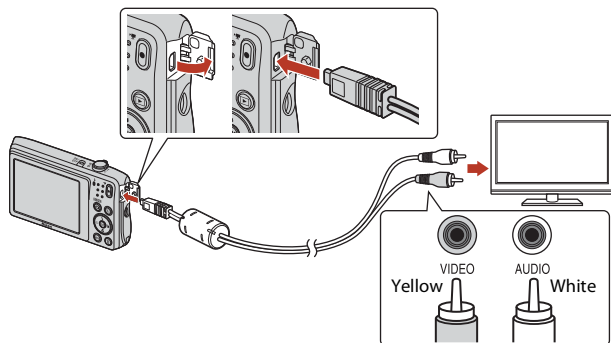

2 Set the TV's input to external video input.

- See the documentation provided with your TV for details.

3 Press and hold down the (playback) button to turn on the camera.

- Images are displayed on the TV.
- The camera screen does not turn on.

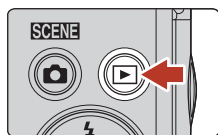

Printing Images Without a Computer

Users of PictBridge-compatible printers can connect the camera directly to the printer and print images without using a computer.

Connecting the Camera to a Printer

- 1 Turn on the printer.
- 2 Turn off the camera and connect it to the printer using the USB cable.
 - Check the shape and direction of the plugs and do not insert or remove the plugs at an angle.

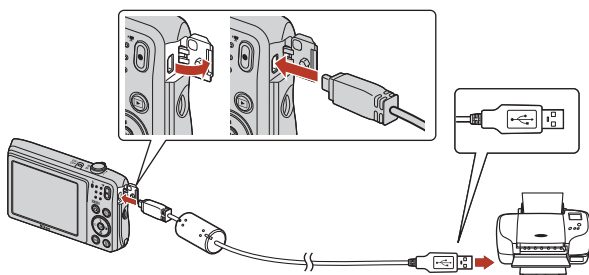

- 3 The camera is automatically turned on.
 - The **PictBridge** startup screen (①) is displayed on the camera screen, followed by the **Print selection** screen (②).

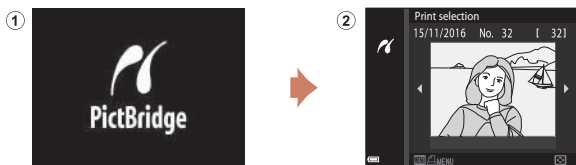

✓ If the PictBridge Startup Screen Is Not Displayed

When **Auto** is selected for **Charge by computer** (131), it may be impossible to print images with direct connection of the camera to some printers. If the PictBridge startup screen is not displayed after the camera is turned on, turn the camera off and disconnect the USB cable. Set **Charge by computer** to **Off** and reconnect the camera to the printer.

Printing Images One at a Time

1 Use the multi selector ◀▶ to select the desired image and press the OK button.

- Move the zoom control toward **W** (⊞) to switch to thumbnail playback or **T** (Ⓚ) to switch to full-frame playback.

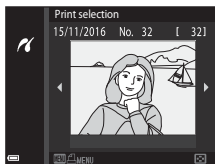

2 Use ▲▼ to select **Copies** and press the OK button.

- Use ▲▼ to set the desired number of copies (up to nine) and press the OK button.

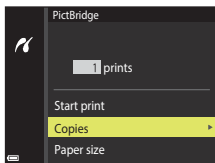

3 Select **Paper size** and press the OK button.

- Select the desired paper size and press the OK button.
- To print with the paper size setting configured on the printer, select **Default**.
- The paper size options available on the camera vary depending on the printer that you use.

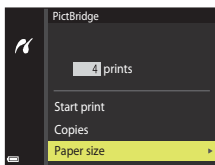

4 Select **Start print** and press the OK button.

- Printing starts.

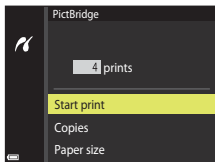

Printing Multiple Images

- 1 When the **Print selection** screen is displayed, press the **MENU** (menu) button.

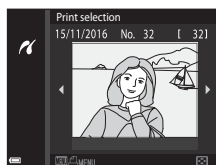

- 2 Use the multi selector ▲▼ to select **Paper size** and press the **OK** button.
 - Select the desired paper size and press the **OK** button.
 - To print with the paper size setting configured on the printer, select **Default**.
 - The paper size options available on the camera vary depending on the printer that you use.
 - To exit the print menu, press the **MENU** button.

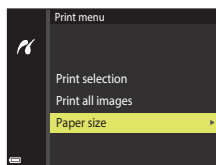

- 3 Select **Print selection** or **Print all images** and press the **OK** button.

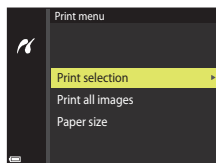

Print selection

Select images (up to 99) and the number of copies (up to 9) of each.

- Use the multi selector ◀▶ to select images, and use ▲▼ to specify the number of copies to be printed.
- Images selected for printing are indicated by 🖨️ and the number of copies to be printed. To cancel the print selection, set the number of copies to 0.
- Move the zoom control toward **T** (🔍) to switch to full-frame playback or **W** (🔲) to switch to thumbnail playback.
- Press the **OK** button when setting is complete. When the screen for confirming the number of print copies is displayed, select **Start print** and press the **OK** button to start printing.

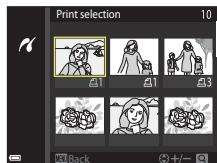

Print all images

One copy each of all images saved in the internal memory, or on the memory card, is printed.

- When the screen for confirming the number of print copies is displayed, select **Start print** and press the **OK** button to start printing.



Transferring Images to a Computer (ViewNX-i)

Installing ViewNX-i

ViewNX-i is free software that enables you to transfer images and movies to your computer for viewing and editing.

To install ViewNX-i, download the latest version of the ViewNX-i installer from the following website and follow the on-screen instructions to complete installation.

ViewNX-i: <http://downloadcenter.nikonimglib.com>

For system requirements and other information, see the Nikon website for your region.

Transferring Images to a Computer

1 Prepare a memory card that contains images.

You can use any of the methods below to transfer images from the memory card to a computer.

- **SD memory card slot/card reader:** Insert the memory card into the card slot of your computer or the card reader (commercially available) that is connected to the computer.
- **Direct USB connection:** Turn the camera off and ensure that the memory card is inserted in the camera. Connect the camera to the computer using the USB cable. The camera automatically turns on.

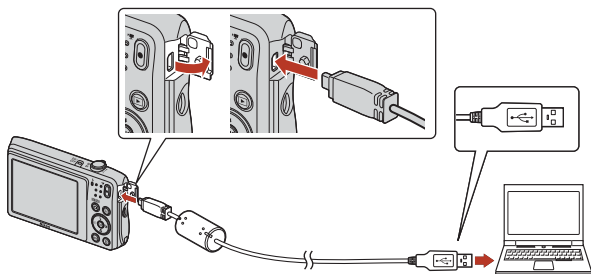

✓ Notes About Connecting the Camera to a Computer

Disconnect all other USB-powered devices from the computer. Connecting the camera and other USB-powered devices to the same computer simultaneously may cause a camera malfunction or excessive power supply from the computer, which could damage the camera or memory card.



If a message is displayed prompting you to choose a program, select Nikon Transfer 2.

- **When using Windows 7**

If the dialog shown on the right is displayed, follow the steps below to select Nikon Transfer 2.

- 1 Under **Import pictures and videos**, click **Change program**. A program selection dialog will be displayed; select Nikon Transfer 2 and click **OK**.
- 2 Double-click the Nikon Transfer 2 icon.



- **When using Windows 10 or Windows 8.1**

If the dialog shown on the right is displayed, click the dialog and then click **Import File/ Nikon Transfer 2**.

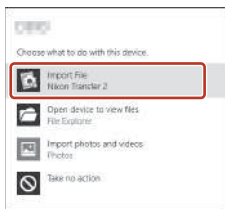

- **When using OS X or macOS**

If Nikon Transfer 2 does not automatically start, launch the **Image Capture** application that comes bundled with Mac while the camera and your computer are connected, and select Nikon Transfer 2 as the default application to open when the camera is connected to your computer.

If the memory card contains a large number of images, it may take a while for Nikon Transfer 2 to start. Wait until Nikon Transfer 2 starts.

Notes About Connecting the USB Cable

Operation is not guaranteed if the camera is connected to the computer via a USB hub.

For More Information on Using ViewNX-i

Consult online help of ViewNX-i.



2 After Nikon Transfer 2 starts, click **Start Transfer**.

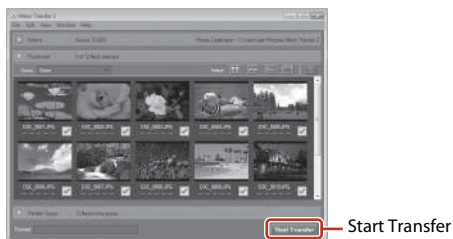

- Image transfer begins. When image transfer is complete, ViewNX-i starts and the transferred images are displayed.

3 Terminate the connection.

- If you are using a card reader or card slot, choose the appropriate option in the computer operating system to eject the removable disk corresponding to the memory card and then remove the memory card from the card reader or card slot.
- If the camera is connected to the computer, turn the camera off and disconnect the USB cable.



Using the Menu

Menu Operations.....	91
Menu Lists	94
The Shooting Menu (The Common Shooting Options)	98
The Shooting Menu (📷 (Auto) Mode)	100
The Smart Portrait Menu	108
The Playback Menu.....	110
The Movie Menu	114
The Network Menu	117
The Setup Menu.....	119



Menu Operations

You can set the menus listed below by pressing the **MENU** (menu) button.

- **Shooting menu**^{1,2}
- **Movie menu**¹
- **Playback menu**³
- **Network menu**
- **Setup menu**

¹ Press the **MENU** button when the shooting screen is displayed.

² Menu icons and available setting options vary depending on the shooting mode.

³ Press the **MENU** button when the playback screen is displayed.

1 Press the **MENU** (menu) button.

- The menu is displayed.

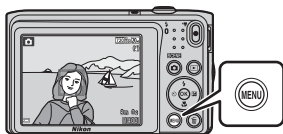

2 Press the multi selector ◀.

- The current menu icon is displayed in yellow.

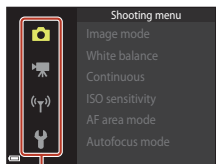

Menu icons

3 Select a menu icon and press the **OK** button.

- The menu options become selectable.

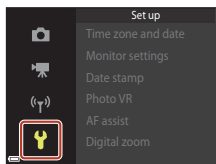

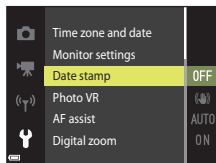

4 Select a menu option and press the **OK** button.

- Certain menu options cannot be set depending on the current shooting mode or the state of the camera.



5 Select a setting and press the **OK** button.

- The setting you selected is applied.
- When you are finished using the menu, press the **MENU** button.
- When a menu is displayed, you can switch to shooting mode by pressing the shutter-release button,  button, or  button.

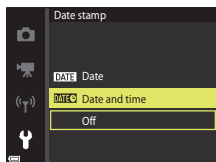

The Image Selection Screen

When an image selection screen such as the one shown on the right is displayed while operating the camera, follow the procedures described below to select the images.



1 Use the multi selector ◀▶ to select the desired image.

- Move the zoom control (📖2) toward **T** (📷) to switch to full-frame playback, or **W** (📱) to switch to thumbnail playback.
- Only one image can be selected for **Rotate image**. Proceed to step 3.

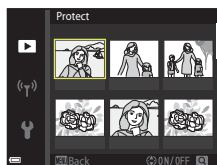

2 Use ▲▼ to select **ON** or **OFF**.

- When **ON** is selected, an icon is displayed below the image. Repeat steps 1 and 2 to select additional images.



3 Press the (OK) button to apply image selection.

- When a confirmation dialog is displayed, follow the on-screen instructions to operate.





Menu Lists

The Shooting Menu

Enter shooting mode → MENU button

Common Shooting Options



Option	Default setting	
Image mode	 5152×3864	98

Auto Mode

Option	Default setting	
White balance	Auto	100
Continuous	Single	102
ISO sensitivity	Auto	103
AF area mode	Target finding AF	104
Autofocus mode	Single AF	107





The Smart Portrait Menu

Enter shooting mode → MENU button →  menu icon →  button

Option		Default setting	
Self-Collage	Number of shots	4	108
	Interval	Medium	108
	Shutter sound	Magic	108
Blink proof		Off	109

The Movie Menu

Enter shooting mode → MENU button →  menu icon →  button

Option	Default setting	
Movie options	 720/30p or  720/25p	114
Autofocus mode	Single AF	115
Movie VR	On (hybrid)	116
Wind noise reduction	Off	116



The Playback Menu

Press the  button (playback mode) → MENU button

Option	
Mark for upload ¹	110
Quick retouch ²	69
D-Lighting ²	69
Red-eye correction	70
Glamour retouch ²	71
Slide show	111
Protect ¹	112
Rotate image ¹	112
Small picture ²	73
Copy ¹	113

¹ Select an image on the image selection screen. See "The Image Selection Screen" (93) for more information.

² Edited images are saved as separate files. Some images may not be edited.

The Network Menu

Press the MENU button →  menu icon →  button

Option	
Airplane mode	117
Connect to smart device	117
Send while shooting	117
Wi-Fi	117
Bluetooth	117
Restore default settings	117



The Setup Menu

Press the MENU button →  menu icon →  button

Option	
Time zone and date	119
Monitor settings	121
Date stamp	123
Photo VR	124
AF assist	125
Digital zoom	125
Sound settings	126
Auto off	126
Format card/Format memory	127
Language	128
Image comment	128
Copyright information	129
Location data	130
Video mode	130
Charge by computer	131
Reset all	132
Conformity marking	132
Firmware version	132



The Shooting Menu (The Common Shooting Options)









Image Mode (Image Size and Quality)

Enter shooting mode* → MENU button → Image mode → 

* This setting can also be changed in shooting modes other than auto. The changed setting is also applied to other shooting modes.

Select the combination of image size and compression ratio to be used when saving images.

The higher the image mode setting, the larger the size at which it can be printed, and the lower the compression ratio, the higher the quality of the images, but the number of images that can be saved is reduced.

Option*	Compression ratio	Aspect ratio (horizontal to vertical)
 20 _M * 5152×3864★	Approx. 1:4	4:3
 20 _M 5152×3864 (default setting)	Approx. 1:8	4:3
 10 _M 3648×2736	Approx. 1:8	4:3
 4 _M 2272×1704	Approx. 1:8	4:3
 2 _M 1600×1200	Approx. 1:8	4:3
VGA 640×480	Approx. 1:8	4:3
 16:9  HiM 5120×2880	Approx. 1:8	16:9
 1:1 3864×3864	Approx. 1:8	1:1

* The numerical values indicate the number of pixels that are captured.
Example:  20_M 5152×3864 = approx. 20 megapixels, 5152 × 3864 pixels



Notes About Printing Images at 1:1 Aspect Ratio

Change the printer setting to “Border” when printing images at a 1:1 aspect ratio. Some printers may not be able to print images at a 1:1 aspect ratio.

Notes About Image Mode

This function may not be available to use in combination with other functions ( 63).

Number of Images That Can Be Saved

- The approximate number of images that can be saved can be checked on the screen when shooting ( 16).
- Note that due to JPEG compression, the number of images that can be saved may vary greatly depending on the image content, even when using memory cards with the same capacity and the same image mode setting. In addition, the number of images that can be saved may vary depending on the make of the memory card.
- If the number of exposures remaining is 10,000 or more, the number of exposures remaining display shows “9999”.



The Shooting Menu (📷 (Auto) Mode)

White Balance (Adjusting Hue)

Enter shooting mode → 📷 (shooting mode) button → 📷 (auto) mode → Ⓜ button → MENU button → White balance → Ⓜ button

Adjust white balance to suit the light source or weather conditions in order to make the colors in images match what you see with your eyes.

Option	Description
AUTO Auto (default setting)	White balance is automatically adjusted.
PRE Preset manual	Use when the desired result is not achieved with Auto , Incandescent , etc. (📖101).
☀ Daylight	Use under direct sunlight.
💡 Incandescent	Use under incandescent lighting.
💡 Fluorescent	Use under fluorescent lighting.
☁ Cloudy	Use under overcast skies.
⚡ Flash	Use with the flash.

✔ Notes About White Balance

- Set the flash to Ⓜ (off) when white balance is set to any setting other than **Auto** and **Flash** (📖50).
- This function may not be available to use in combination with other functions (📖63).



Using Preset Manual

Follow the procedures described below to measure the white balance value under the lighting used during shooting.

1 Place a white or gray reference object under the lighting that will be used during shooting.

2 Use the multi selector ▲▼ to select **Preset manual** in the **White balance** menu, and press the **OK** button.

- The lens extends to the zoom position for measurement.

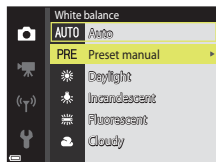

3 Select **Measure**.

- To apply the last measured value, select **Cancel** and press the **OK** button.

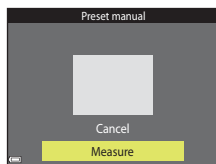

4 Frame the white or gray reference object in the measuring window, and press the **OK** button to measure the value.

- The shutter is released and measurement is complete (no image is saved).

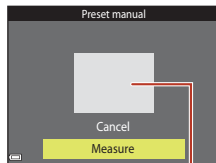





Measuring window



✓ Notes About Preset Manual

A value for flash lighting cannot be measured with **Preset manual**. When shooting using the flash, set **White balance** to **Auto** or **Flash**.



Continuous Shooting

Enter shooting mode →  (shooting mode) button →  (auto) mode → 
button → MENU button → Continuous →  button





Option	Description
 Single (default setting)	One image is captured each time the shutter-release button is pressed.
 Continuous	While the shutter-release button is held all the way down, images are captured continuously. <ul style="list-style-type: none">The frame rate for continuous shooting is about 1.1 fps and the maximum number of continuous shots is about 6 (when image mode is set to  5152x3864).

Notes About Continuous Shooting

- Focus, exposure, and white balance are fixed at the values determined with the first image in each series.
- It may take some time to save the images after shooting.
- This function may not be available to use in combination with other functions ( 63).



ISO Sensitivity

Enter shooting mode →  (shooting mode) button →  (auto) mode →  button → MENU button → ISO sensitivity →  button

A higher ISO sensitivity allows darker subjects to be captured. Additionally, even with subjects of similar brightness, pictures can be taken at faster shutter speeds, and blurring caused by camera shake and subject movement can be reduced.

- When a higher ISO sensitivity is set, images may contain noise.

Option	Description
AUTO Auto (default setting)	Sensitivity is automatically selected from the range of ISO 80 to 1600.
ISO Fixed range auto	The range in which the camera automatically adjusts ISO sensitivity can be selected from ISO 80-400 or ISO 80-800 .
80, 100, 200, 400, 800, 1600, 3200	ISO sensitivity is fixed at the specified value.

Notes About ISO Sensitivity

This function may not be available to use in combination with other functions ( 63).

Notes About ISO 3200

When **ISO sensitivity** is set to **3200**, the available **Image mode** settings are limited to **4M 2272×1704**, **2M 1600×1200**, and **VGA 640×480**.  is displayed next to the ISO sensitivity indicator on the screen.







ISO Sensitivity Display on the Shooting Screen





- When **Auto** is selected, **ISO** is displayed when the ISO sensitivity increases.
- When **Fixed range auto** is selected, the maximum value for ISO sensitivity is displayed.





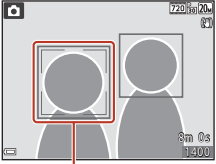
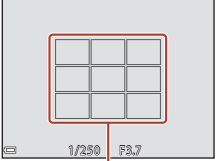

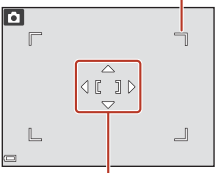

AF Area Mode

Enter shooting mode →  (shooting mode) button →  (auto) mode →  button → MENU button → AF area mode →  button

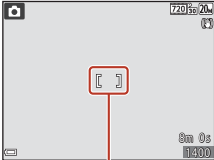
Set how the camera selects the focus area for autofocus.

Option	Description
 Face priority	<p>When the camera detects a human face, it focuses on that face. See “Using Face Detection” (📖58) for more information.</p>  <p>Focus area</p> <p>When framing a composition with no human subjects or detected faces, the camera automatically selects one or more of the nine focus areas containing the subject closest to the camera when the shutter-release button is pressed halfway.</p>  <p>Focus areas</p>
 Manual	<p>Use the multi selector  to move the focus area to where you want to focus.</p> <ul style="list-style-type: none"> To use the multi selector to configure the flash mode or other settings, press the  button. To return to moving the focus area, press the  button again.  <p>Scope of movable focus area</p> <p>Focus area</p>



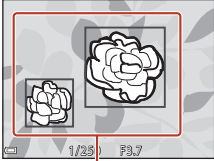





Option	Description
<p>[] Center</p>	<p>The camera focuses on the subject in the center of the frame.</p>  <p style="text-align: center;">Focus area</p>
<p> Subject tracking</p>	<p>Use this function to take pictures of moving subjects. Register the subject on which the camera focuses. The focus area automatically moves to track the subject. See “Using Subject Tracking” ( 106) for more information.</p> 
<p>[] Target finding AF (default setting)</p>	<p>When the camera detects the main subject, it focuses on that subject. See “Using Target Finding AF” ( 57) for more information.</p>  <p style="text-align: center;">Focus areas</p>

Notes About AF Area Mode



- When digital zoom is in effect, the camera focuses in the center of the frame regardless of the **AF area mode** setting.
- This function may not be available to use in combination with other functions ( 63).



Using Subject Tracking

Enter shooting mode →  (shooting mode) button →  (auto) mode →  button → MENU button → AF area mode →  button →  Subject tracking →  button → MENU button

1 Register a subject.

- Align the subject that you want to track with the border in the center of the frame and press the  button.
- When the subject is registered, a yellow border (focus area) is displayed around it and the camera begins tracking the subject.
- If the subject cannot be registered, the border is displayed in red. Change the composition and try registering the subject again.
- To cancel subject registration, press the  button.
- If the camera can no longer track the registered subject, the focus area disappears. Register the subject again.

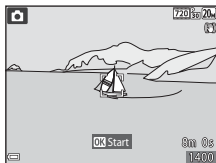

2 Press the shutter-release button all the way to take the picture.

- If the shutter-release button is pressed while the focus area is not displayed, the camera focuses on the subject in the center of the frame.

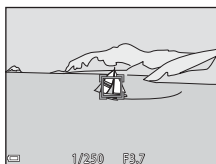





Notes About Subject Tracking

- If you perform operations such as zooming while the camera is tracking the subject, the registration is canceled.
- Subject tracking may not be possible in certain shooting conditions.



Autofocus Mode

Enter shooting mode →  (shooting mode) button →  (auto) mode →  button → MENU button → Autofocus mode →  button

Set how the camera focuses when shooting still images.

Option	Description
AF-S Single AF (default setting)	The camera focuses only when the shutter-release button is pressed halfway.
AF-F Full-time AF	The camera continues focusing even when the shutter-release button is not pressed halfway. The sound of lens drive movement is heard while the camera focuses.

Autofocus Mode for Movie Recording

Autofocus mode for movie recording can be set with **Autofocus mode** (115) in the movie menu.



The Smart Portrait Menu

- See “Image Mode (Image Size and Quality)” (📖98) for information about **Image mode**.





Self-Collage

Enter shooting mode → 📷 (shooting mode) button → 😊 Smart portrait mode → Ⓞ button → MENU button → Self-Collage → Ⓞ button

Option	Description
Number of shots	Set the number of shots that the camera automatically captures (number of captured images for an aggregated image). <ul style="list-style-type: none">• 4 (default setting) or 9 can be selected.
Interval	Set the interval time between each shot. <ul style="list-style-type: none">• Short, Medium (default setting), or Long can be selected.
Shutter sound	Set whether to activate the shutter sound when shooting with the self-collage function. <ul style="list-style-type: none">• Standard, SLR, Magic (default setting), or Off can be selected.• The same setting that is specified for Shutter sound in Sound settings in the setup menu is not applied to this setting.



Blink Proof

Enter shooting mode →  (shooting mode) button →  Smart portrait mode
→  button → MENU button → Blink proof →  button

Option	Description
 On	<p>The camera automatically releases the shutter twice with every shot and saves one image in which the subject's eyes are open.</p> <ul style="list-style-type: none">• If the camera saved an image in which the subject's eyes may have been closed, the dialog shown on the right is displayed for a few seconds.• The flash cannot be used.
Off (default setting)	Turns the blink proof off.

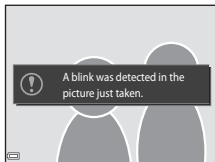

Notes About Blink Proof



This function may not be available to use in combination with other functions ( 63).



The Playback Menu

- See “Editing Images (Still Images)” (📖68) for information about image editing functions.

Mark for Upload

Press the  button (playback mode) → MENU button → Mark for upload →  button



Select still images in the camera to upload them to a wirelessly connected smart device using the SnapBridge app.

On the image selection screen (📖93), select or deselect images for the **Mark for upload** function.

- The image size that can be uploaded is restricted to 2 megapixels. Use **Download pictures** in the SnapBridge app to upload images at their original size.
- Movies cannot be selected for upload.
- Note that when you select **Reset all** (📖132) in the setup menu or **Restore default settings** (📖118) in the network menu, the Mark for upload settings that you made are canceled.





Slide Show

Press the  button (playback mode) → MENU button → Slide show →  button



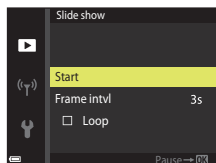

Play back images one by one in an automated “slide show.” When movie files are played back in the slide show, only the first frame of each movie is displayed.

1 Use the multi selector to select **Start** and press the button.

- The slide show begins.
- To change the interval between images, select **Frame intvl**, press the  button, and specify the desired interval time before selecting **Start**.
- To repeat the slide show automatically, select **Loop** and press the  button before selecting **Start**.
- The maximum playback time is up to about 30 minutes even if **Loop** is enabled.





2 End or restart the slide show.

- The screen shown on the right is displayed after the slide show ends or is paused. To exit the show, select  and then press the  button. To resume the slide show, select  and then press the  button.





Operations During Playback

- Use the multi selector  to display the previous/next image. Press and hold to rewind/fast forward.
- Press the  button to pause or end the slide show.



Protect



Press the  button (playback mode) → MENU button → Protect →  button

The camera protects selected images from accidental deletion.

Select images to protect or cancel protection from the image selection screen (93).

Note that formatting the memory card or the camera's internal memory permanently deletes all data including protected files (127).

Rotate Image

Press the  button (playback mode) → MENU button → Rotate image →  button

Specify the orientation in which saved images are displayed during playback. Still images can be rotated 90 degrees clockwise or 90 degrees counterclockwise.

Select an image from the image selection screen (93). When the Rotate image screen is displayed, press the multi selector  to rotate the image 90 degrees.



Rotate 90 degrees
counterclockwise





Rotate 90 degrees
clockwise

Press the  button to finalize display orientation, and save orientation information with the image.





Copy (Copy Between the Memory Card and Internal Memory)

Press the  button (playback mode) → MENU button → Copy →  button

Images can be copied between a memory card and the internal memory.

- When a memory card that contains no images is inserted and the camera is switched to playback mode, **Memory contains no images.** is displayed. In that case, press the MENU button to select **Copy**.

- 1 Use the multi selector   to select a destination option to which images are copied and press the  button.

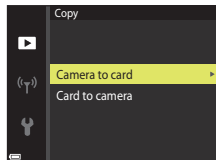

- 2 Select a copy option and press the  button.

- When you choose **Selected images**, use the image selection screen to specify images (93).

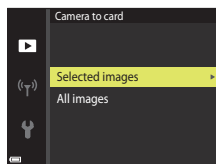



Notes About Copying Images

- Only files in formats that this camera can record can be copied.
- Operation is not guaranteed with images captured with another make of camera or that have been modified on a computer.









The Movie Menu





Movie Options

Enter shooting mode → MENU button →  menu icon → Movie options →  button

Select the desired movie option to record. The movie options that can be selected vary depending on the **Video mode** setting ([130](#)).



- Memory cards with an SD Speed Class rating of 6 or faster are recommended for recording movies ([163](#)).

Option (Image size/ Frame rate)	Image size	Aspect ratio (horizontal to vertical)
 720/30p  720/25p (default setting*)	1280 × 720	16:9
 480/30p  480/25p	640 × 480	4:3
 240/30p  240/25p	320 × 240	4:3

* When recording in the internal memory, the default setting is  **480/30p** or  **480/25p**, and  **720/30p** or  **720/25p** cannot be selected.



Autofocus Mode

Enter shooting mode → MENU button →  menu icon → Autofocus mode →  button

Set how the camera focuses in movie mode.

Option	Description
AF-S Single AF (default setting)	Focus is locked when movie recording starts. Select this option when the distance between the camera and subject will remain fairly consistent during movie recording.
AF-F Full-time AF	The camera focuses continuously during movie recording. Select this option when the distance between the camera and subject will change significantly during recording. The sound of the camera focusing may be heard in the recorded movie. Use of Single AF is recommended to prevent the sound of the camera focusing from interfering with recording.





Movie VR

Enter shooting mode → MENU button →  menu icon → Movie VR →  button

Select the vibration reduction setting used when recording movies.



Select **Off** when using a tripod to stabilize the camera during shooting.

Option	Description
 * On (hybrid) (default setting)	Performs optical compensation for camera shake using lens shift VR and simultaneously performs electronic VR using image processing. The angle of view (i.e., the area visible in the frame) becomes narrower.
 On	Performs compensation for camera shake using lens shift VR.
Off	Compensation is not performed.

Notes About Movie VR

- The effects of camera shake may not be completely eliminated in some situations.

Wind Noise Reduction

Enter shooting mode → MENU button →  menu icon → Wind noise reduction →  button

Option	Description
 On	Reduces the sound that is produced when wind passes over the microphone during movie recording. Other sounds may become difficult to hear during playback.
Off (default setting)	Wind noise reduction is disabled.



The Network Menu

Press the **MENU** button → «T» menu icon → Ⓞ button

Configure the wireless network settings to connect the camera and a smart device.

- Some settings cannot be changed while a wireless connection is established. To change the settings, disable the wireless connection.

Option	Description
Airplane mode	Select On to turn off all wireless connections.
Connect to smart device	Select when connecting the camera and a smart device by using the SnapBridge app (📖23).
Send while shooting	Set the conditions for automatically sending images to a smart device. <ul style="list-style-type: none"> • The image size that can be uploaded is restricted to 2 megapixels. Use Download pictures in the SnapBridge app to upload images at their original size.
Wi-Fi	Network settings SSID* : Change the SSID. Set a 1- to 32-character alphanumeric SSID. Auth./encrypt. : Select whether or not to encrypt the communications between the camera and the connected smart device. Communications are not encrypted when Open is selected. Password* : Set the password. Set an 8- to 36-character alphanumeric password. Channel : Select the channel used for wireless connections.
	Current settings Display the current settings.
	Connection Select Disable to turn off Bluetooth communication.
	Paired devices Change the smart device to connect with, or delete the connected smart device. Up to five smart devices can be registered in the camera, but the camera can connect to only one device at a time.
Bluetooth	Send while off Set whether or not to allow the camera to communicate with the smart device when the camera is off or in standby mode (📖17).



Option	Description
Restore default settings	Restore all network menu settings to their default values.

* See “Operating the Text Input Keyboard” (118) for information on how to enter alphanumeric characters.

Operating the Text Input Keyboard

- Use the multi selector ▲▼◀▶ to select alphanumeric characters. Press the **OK** button to enter the selected character in the text field and move the cursor to the next space.
- To move the cursor in the text field, select ← or → on the keyboard, and press the **OK** button.
- To delete one character, press the **🗑** button.
- To apply the setting, select ↵ on the keyboard and press the **OK** button.

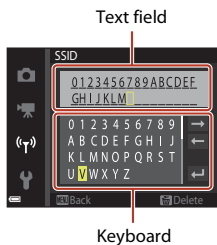

The Setup Menu

Time Zone and Date

Press the **MENU** button → **Y** menu icon → Time zone and date → **OK** button

Set the camera clock.

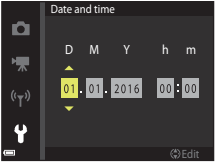
Option	Description
Sync with smart device	Select On to synchronize the date and time setting with a smart device. Enable the clock synchronization function of the SnapBridge app.
Date and time*	<ul style="list-style-type: none">Select a field: Press the multi selector ◀▶.Edit the date and time: Press ▲▼.Apply the setting: Select the minute setting and press the OK button. 
Date format	Select Year/Month/Day , Month/Day/Year , or Day/Month/Year .
Time zone*	Set time zone and daylight saving time. <ul style="list-style-type: none">When Travel destination (🏠) is set after having set the home time zone (🏠), the time difference between the travel destination and the home time zone is automatically calculated, and the date and time are saved for the selected region.

* Can be set only when **Sync with smart device** is set to **Off**.

Setting the Time Zone

1 Use the multi selector ▲▼ to select **Time zone** and press the **OK** button.

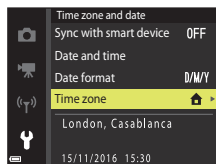

2 Select Home time zone or Travel destination and press the button.



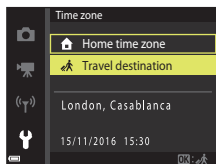

- The date and time displayed on the screen changes depending on whether the home time zone or travel destination is selected.

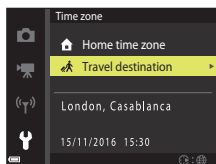

3 Press .



4 Use to select the time zone.

- Press  to enable daylight saving time function, and  is displayed. Press  to disable the daylight saving time function.
- Press the  button to apply the time zone.
- If the correct time is not displayed for the home or travel destination time zone setting, set the appropriate time in **Date and time**.

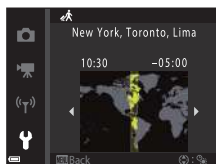





Monitor Settings



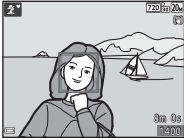

Press the MENU button →  menu icon → Monitor settings →  button

Option	Description
Photo info	Set whether or not to display information on the screen.
Help display	The descriptions of functions are displayed while changing the shooting mode or while the setting screen is displayed. <ul style="list-style-type: none">• Default setting: On
Image review	Set whether or not to display the captured image immediately after shooting. <ul style="list-style-type: none">• Default setting: On
Brightness	Adjust the brightness. <ul style="list-style-type: none">• Default setting: 3

Photo Info

	Shooting mode	Playback mode
Show info		
Auto info (default setting)	The same information as shown in Show info is displayed, and it is hidden as shown in Hide info if no operations are performed for a few seconds. The information is displayed again when an operation is performed.	
Hide info		



	Shooting mode	Playback mode
Framing grid+auto info	 <p>In addition to the information shown in Auto info, a framing grid is displayed to help frame pictures. The framing grid is not displayed while recording movies.</p>	 <p>Same as Auto info.</p>
Movie frame+auto info	 <p>In addition to the information shown in Auto info, a frame is displayed before movie recording begins that represents the area that will be captured when recording movies. The movie frame is not displayed while recording movies.</p>	 <p>Same as Auto info.</p>



Date Stamp

Press the **MENU** button → **Y** menu icon → Date stamp → **OK** button

The shooting date and time can be stamped on images when shooting. The information can be printed even when using a printer that does not support the date imprinting function.



Option	Description
DATE Date	Date is stamped on images.
DATE  Date and time	Date and time are stamped on images.
Off (default setting)	Date and time are not stamped on images.

Notes About Date Stamp

- Stamped date and time form a permanent part of image data and cannot be deleted. The date and time cannot be stamped on images after they have been captured.
- The date and time cannot be stamped in the following situations:
 - When using **Panorama assist** scene mode
 - When shooting movies
- The stamped date and time may be difficult to read when using a small image size.

Printing a Shooting Date and Time on Images Without a Date Stamp





You can transfer images to a computer and use the ViewNX-i software ( 87) to imprint the shooting date and time on the images when they are printed.



Photo VR

Press the **MENU** button →  menu icon → Photo VR →  button

Select the vibration reduction setting used when shooting still images.
Select **Off** when using a tripod to stabilize the camera during shooting.



Option	Description
 On (default setting)	Compensation for camera shake is performed using lens shift VR.
Off	Compensation is not performed.

Notes About Photo VR

- After turning on the camera or after switching from playback mode to shooting mode, wait until the shooting screen is ready before taking pictures.
- Images on the screen may be displayed blurry immediately after shooting.
- The effects of camera shake may not be completely eliminated in some situations.





AF Assist

Press the MENU button →  menu icon → AF assist →  button

Option	Description
AUTO Auto (default setting)	The AF-assist illuminator automatically lights up when you press the shutter-release button under dim lighting. The illuminator has a range of about 2.0 m (6 ft 6 in.) at the maximum wide-angle position and about 1.5 m (4 ft 11 in.) at the maximum telephoto position. <ul style="list-style-type: none">Note that for some scene modes or focus areas, the AF-assist illuminator may not light.
Off	The AF-assist illuminator does not light.

Digital Zoom

Press the MENU button →  menu icon → Digital zoom →  button

Option	Description
On (default setting)	Digital zoom is enabled.
Off	Digital zoom is disabled.

Notes About Digital Zoom

- Digital zoom cannot be used in the following shooting modes:
 - Portrait**, **Night portrait**, or **Pet portrait** scene mode
 - Smart portrait mode
- Digital zoom cannot be used in other shooting modes when using certain settings (63).





Sound Settings

Press the MENU button →  menu icon → Sound settings →  button

Option	Description
Button sound	When On (default setting) is selected, the camera produces one beep when operations are performed, two beeps when focus is acquired on the subject, and three beeps when an error occurs. The start-up sound is also produced. <ul style="list-style-type: none">• Sounds are disabled when using Pet portrait scene mode.
Shutter sound	When On (default setting) is selected, the shutter sound is produced when the shutter is released. <ul style="list-style-type: none">• The shutter sound is not produced when recording movies or when using Pet portrait scene mode.

Auto Off

Press the MENU button →  menu icon → Auto off →  button

Set the amount of time that elapses before the camera enters standby mode ( 17). You can select **30 s**, **1 min** (default setting), **5 min**, or **30 min**.



Setting the Auto Off Function

The time that passes before the camera enters standby mode is fixed in the following situations:

- When a menu is displayed: 3 minutes (when auto off is set to **30 s** or **1 min**)
- When shooting using **Pet portrait auto release**: 5 minutes (when auto off is set to **30 s** or **1 min**)
- When shooting using **Smile timer**: 5 minutes (when auto off is set to **30 s** or **1 min**)
- When the EH-62G AC Adapter is connected: 30 minutes
- When an audio video cable is connected: 30 minutes
- When **Connect to smart device** is selected in the network menu: 30 minutes
- When a wireless connection is established after the camera is turned on for the first time: 30 minutes



Format Card/Format Memory

Press the MENU button →  menu icon → Format card/Format memory →  button

Use this option to format a memory card or the internal memory.

Formatting the memory cards or internal memory permanently deletes all data. Data that has been deleted cannot be recovered. Make sure to save important images to a computer before formatting.

Formatting a Memory Card

- Insert a memory card into the camera.
- Select **Format card** in the setup menu and then press the  button.

Formatting the Internal Memory

- Remove the memory card from the camera.
- Select **Format memory** in the setup menu and then press the  button.

To start formatting, select **Format** on the screen that is displayed and press the  button.

- Do not turn the camera off or open the battery-chamber/memory card slot cover during formatting.
- You may not be able to select this setting while a wireless connection is established.



Language

Press the MENU button → Y menu icon → Language → OK button

Select a language for display of camera menus and messages.

Image Comment

Press the MENU button → Y menu icon → Image comment → OK button

Attach a comment that was previously registered to images that will be captured. You can imprint the attached comment to images that will be sent to a smart device using the SnapBridge app. See the SnapBridge app online help for more information. You can also check the attached comment with ViewNX-i metadata.

Option	Description
Attach comment	<p>A comment registered with Input comment is attached to images.</p> <ul style="list-style-type: none">• Select Attach comment, press ►, and set the check box to on (✔). When you press the OK button, the setting is enabled, and the comment will be attached to the images captured afterwards.
Input comment	<p>You can register a comment of up to 36 alphanumeric characters.</p> <ul style="list-style-type: none">• Select Input comment, press ►, and the input screen is displayed. See “Operating the Text Input Keyboard” (📖118) for information about the input method.

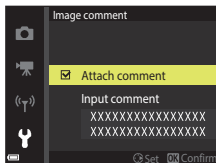

Image Comments Display

Image comments are not displayed even if images are played back on the camera.



Copyright Information

Press the **MENU** button → **Y** menu icon → Copyright information → **OK** button

Attach the copyright information that was previously registered to images that will be captured.

You can imprint the attached copyright information to images that will be sent to a smart device using the SnapBridge app. See the SnapBridge app online help for more information.

You can also check the attached copyright information with ViewNX-i metadata.

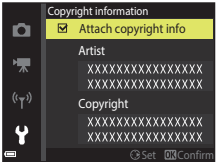
Option	Description
Attach copyright info	<p>Copyright information registered with Artist and Copyright is attached to the images.</p> <ul style="list-style-type: none">Select Attach copyright info, press ▶, and set the check box to on (✓). When you press the OK button, the setting is enabled, and the copyright information will be attached to the images captured afterwards. 
Artist	<p>You can register an artist name of up to 36 alphanumeric characters.</p> <ul style="list-style-type: none">Select Artist, press ▶, and the input screen is displayed. See “Operating the Text Input Keyboard” (📖118) for information about the input method.
Copyright	<p>You can register a copyright owner name of up to 54 alphanumeric characters.</p> <ul style="list-style-type: none">Select Copyright, press ▶, and the input screen is displayed. See “Operating the Text Input Keyboard” (📖118) for information about the input method.

✓ Notes About Copyright Information



- To prevent illegal use of artist names and copyright owner names when lending or transferring ownership of the camera, make sure to disable the **Attach copyright info** setting. Also, make sure that the artist name and copyright owner name are blank.
- Nikon is not responsible for any kind of trouble or damage resulting from the use of **Copyright information**.

📎 Copyright Information Display

- Copyright information is not displayed even if images are played back on the camera.
- When copyright information is entered for both **Artist** and **Copyright**, only the **Copyright** entry is attached to the images in the SnapBridge app.





Location Data

Press the **MENU** button →  menu icon → Location data →  button

Set whether or not to add shooting location information to the images that you take.

Option	Description
Download from device	Select Yes to add location information from a smart device to the images that you take. Enable the location information function of the SnapBridge app.
Position	Display the obtained location information. <ul style="list-style-type: none">• The information is not updated while it is being displayed. To update it, perform Position again.

Video Mode

Press the **MENU** button →  menu icon → Video mode →  button

Adjust settings necessary for connection to a TV.



Select from **NTSC** and **PAL**.

Both **NTSC** and **PAL** are standards for analog color television broadcasting.

- The available frame rates in **Movie options** ( 114) vary depending on the video mode setting.



Charge by Computer

Press the MENU button →  menu icon → Charge by computer →  button

Option	Description
AUTO Auto (default setting)	When the camera is connected to a computer that is running (81), the battery inserted into the camera is automatically charged using power supplied by the computer.
Off	The battery inserted into the camera is not charged when the camera is connected to a computer.

Notes About Charging with a Computer

- When connected to a computer, the camera turns on and starts charging. If the camera is turned off, charging stops.
- About 3 hours are required to charge a fully exhausted battery. Charging time increases when images are transferred while the battery is charging.
- The camera turns off automatically if there is no communication with the computer for 30 minutes after the battery has finished charging.



When the Charge Lamp Quickly Flashes Green

Charging cannot be performed, possibly due to one of the reasons described below.

- The ambient temperature is not suited to charging. Charge the battery indoors with an ambient temperature of 5°C to 35°C (41°F to 95°F).
- The USB cable is not connected correctly, or the battery is faulty. Make sure that the USB cable is connected correctly or replace the battery if necessary.
- The computer is in sleep mode and is not supplying power. Wake up the computer.
- The battery cannot be charged because the computer cannot supply power to the camera due to the computer's settings or its specifications.



Reset All

Press the **MENU** button →  menu icon → **Reset all** →  button



When **Reset** is selected, the camera's settings are restored to their default values.

- The network menu settings are also restored to their default values.
- Some settings, such as **Time zone and date** or **Language**, are not reset.
- You may not be able to select this setting while a wireless connection is established.

Resetting File Numbering

To reset file numbering to "0001", delete all images saved on the memory card or in the internal memory (19) before selecting **Reset all**.

Conformity Marking

Press the **MENU** button →  menu icon → **Conformity marking** →  button

View some of the conformity markings that the camera complies with.

Firmware Version

Press the **MENU** button →  menu icon → **Firmware version** →  button

View the current camera firmware version.

- You may not be able to select this setting while a wireless connection is established.



Technical Notes

Notices.....	134
Notes About Wireless Communication Functions	136
Caring for the Product	139
The Camera	139
The Battery	140
The Charging AC Adapter.....	141
Memory Cards.....	142
Cleaning and Storage	143
Cleaning	143
Storage	143
Error Messages	144
Troubleshooting	148
File Names.....	157
Optional Accessories.....	158
Specifications.....	159
Memory Cards That Can Be Used.....	163
Index	165



Notices

Notices for Customers in the U.S.A.

IMPORTANT SAFETY INSTRUCTIONS - SAVE THESE INSTRUCTIONS.

DANGER - TO REDUCE THE RISK OF FIRE OR ELECTRIC SHOCK, CAREFULLY FOLLOW THESE INSTRUCTIONS

For connection to a supply not in the U.S.A., use an attachment plug adapter of the proper configuration for the power outlet if needed.

The power supply unit is intended to be correctly orientated in a vertical or floor mount position.

Federal Communications Commission (FCC) Radio Frequency Interference Statement

This equipment has been tested and found to comply with the limits for a Class B digital device, pursuant to Part 15 of the FCC rules. These limits are designed to provide reasonable protection against harmful interference in a residential installation.

This equipment generates, uses, and can radiate radio frequency energy and, if not installed and used in accordance with the instructions, may cause harmful interference to radio communications. However, there is no guarantee that interference will not occur in a particular installation. If this equipment does cause harmful interference to radio or television reception, which can be determined by turning the equipment off and on, the user is encouraged to try to correct the interference by one or more of the following measures:

- Reorient or relocate the receiving antenna.
- Increase the separation between the equipment and receiver.
- Connect the equipment into an outlet on a circuit different from that to which the receiver is connected.
- Consult the dealer or an experienced radio/television technician for help.



CAUTIONS

Modifications

The FCC requires the user to be notified that any changes or modifications made to this device that are not expressly approved by Nikon Corporation may void the user's authority to operate the equipment.

Interface Cables

Use the interface cables sold or provided by Nikon for your equipment. Using other interface cables may exceed the limits of Class B Part 15 of the FCC rules.



Notice for Customers in the State of California

WARNING

Handling the cord on this product will expose you to lead, a chemical known to the State of California to cause birth defects or other reproductive harm.

Wash hands after handling.

Nikon Inc.,

1300 Walt Whitman Road, Melville, New York 11747-3064, U.S.A.

Tel: 631-547-4200

Notice for Customers in Canada

CAN ICES-3 B / NMB-3 B

Notices for Customers in Europe

CAUTIONS

RISK OF EXPLOSION IF BATTERY IS REPLACED BY AN INCORRECT TYPE.

DISPOSE OF USED BATTERIES ACCORDING TO THE INSTRUCTIONS.

This symbol indicates that electrical and electronic equipment is to be collected separately.

The following apply only to users in European countries:

- This product is designated for separate collection at an appropriate collection point. Do not dispose of as household waste.
- Separate collection and recycling helps conserve natural resources and prevent negative consequences for human health and the environment that might result from incorrect disposal.
- For more information, contact the retailer or the local authorities in charge of waste management.



This symbol on the battery indicates that the battery is to be collected separately.

The following apply only to users in European countries:

- All batteries, whether marked with this symbol or not, are designated for separate collection at an appropriate collection point. Do not dispose of as household waste.
- For more information, contact the retailer or the local authorities in charge of waste management.



Notes About Wireless Communication Functions

Restrictions on Wireless Devices

The wireless transceiver included in this product conforms to wireless regulations in the country of sale and is not for use in other countries (products purchased in the EU or EFTA can be used anywhere within the EU and EFTA). Nikon does not accept liability for use in other countries. Users who are unsure as to the original country of sale should consult with their local Nikon service center or Nikon-authorized service representative. This restriction applies to wireless operation only and not to any other use of the product.

Security

Although one of the benefits of this product is that it allows others to freely connect for the wireless exchange of data anywhere within its range, the following may occur if security is not enabled:

- Data theft: Malicious third-parties may intercept wireless transmissions to steal user IDs, passwords, and other personal information.
- Unauthorized access: Unauthorized users may gain access to the network and alter data or perform other malicious actions. Note that due to the design of wireless networks, specialized attacks may allow unauthorized access even when security is enabled. Nikon is not responsible for data or information leaks that may occur during data transfer.
- Do not access networks that you are not permitted to use, even if they are displayed on your smartphone or tablet. Doing so may be regarded as unauthorized access. Only access networks that you are permitted to use.

Personal Information Management and Disclaimer

- User information registered and configured on the product, including wireless LAN connection settings and other personal information, is susceptible to alteration and loss resulting from operational error, static electricity, accident, malfunction, repair or other handling. Always keep separate copies of important information. Nikon is not responsible for any direct or indirect damages or lost profits resulting from alteration or loss of content that is not attributable to Nikon.
- Before discarding this product or transferring it to another owner, perform **Reset all** in the setup menu (📖91) to delete all user information registered and configured with the product, including wireless LAN connection settings and other personal information.
- Nikon is not responsible for any damages resulting from unauthorized use of this product by third parties in the event that the product is stolen or lost.



Precautions when Exporting or Carrying This Product Abroad

This product is controlled by the United States Export Administration Regulations (EAR). The permission of the United States government is not required for export to countries other than the following, which as of this writing are subject to embargo or special controls: Cuba, Iran, North Korea, Sudan, and Syria (list subject to change).

Notice for Customers in the U.S.A. and Canada

Federal Communications Commission (FCC) and Industry of Canada (IC)

Declaration of Conformity

This device complies with Part 15 of FCC Rules and Industry Canada licence-exempt RSS standard(s). Operation is subject to the following two conditions: (1) this device may not cause interference, and (2) this device must accept any interference, including interference that may cause undesired operation of this device.

FCC/IC RF Exposure Statement

This transmitter must not be co-located or operated in conjunction with any other antenna or transmitter.

The available scientific evidence does not show that any health problems are associated with using low power wireless devices. There is no proof, however, that these low power wireless devices are absolutely safe. Low power wireless devices emit low levels of radio frequency energy (RF) in the microwave range while being used. Whereas high levels of RF can produce health effects (by heating tissue), exposure of low-level RF that does not produce heating effects causes no known adverse health effects. Many studies of low-level RF exposures have not found any biological effects. Some studies have suggested that some biological effects might occur, but such findings have not been confirmed by additional research.

COOLPIX A300, which is equipped with a WM-BN-BM-26_A (FCC ID:2AAD3JA1D0J0 / IC ID:4634A-3152EC) Wireless LAN Module, has been tested and found to comply with FCC/IC radiation exposure limits set forth for an uncontrolled environment and meets the FCC radio frequency (RF) Exposure Guidelines in Supplement C to OET65 and RSS-102 of the IC radio frequency (RF) Exposure rules. Please refer to the SAR test report that was uploaded to FCC website.



Notice for Customers in Europe

Declaration of Conformity (Europe)

Hereby, Nikon Corporation declares that the radio equipment type COOLPIX A300 is in compliance with Directive 2014/53/EU.

The full text of the EU declaration of conformity is available at the following internet address:

http://imaging.nikon.com/support/pdf/DoC_A300.pdf.

- Maximum output power: 11.36 dBm (EIRP)
- Operating frequency:
 - Wi-Fi: 2412–2462 MHz (1-11 channels)
 - Bluetooth: 2402–2480 MHz
 - Bluetooth Low Energy: 2402–2480 MHz
 - NFC: 13.56 MHz



Caring for the Product

Observe the precautions described below in addition to the warnings in “For Your Safety” (📖vi–viii) when using or storing the device.

The Camera

Do Not Apply Strong Impact to the Camera

The product may malfunction if subjected to strong shock or vibration. In addition, do not touch or apply force to the lens or lens cover.

Keep Dry

The device will be damaged if immersed in water or subjected to high humidity.

Avoid Sudden Changes in Temperature

Sudden changes in temperature, such as when entering or leaving a heated building on a cold day, can cause condensation to form inside the device. To prevent condensation, place the device in a carrying case or a plastic bag before exposing it to sudden changes in temperature.

Keep Away from Strong Magnetic Fields

Do not use or store this device in the vicinity of equipment that generates strong electromagnetic radiation or magnetic fields. Doing so could result in loss of data or camera malfunction.

Do Not Point the Lens at Strong Light Sources for Extended Periods

Avoid pointing the lens at the sun or other strong light sources for extended periods when using or storing the camera. Intense light may cause the image sensor to deteriorate or produce a white blur effect in photographs.

Turn the Product Off Before Removing or Disconnecting the Power Source or Memory Card

Do not remove the battery while the product is on, or while images are being saved or deleted. Forcibly cutting power in these circumstances could result in loss of data or in damage to the memory card or internal circuitry.



Notes About the Monitor

- Monitors (including electronic viewfinders) are constructed with extremely high precision; at least 99.99% of pixels are effective, with no more than 0.01% being missing or defective. Hence while these displays may contain pixels that are always lit (white, red, blue, or green) or always off (black), this is not a malfunction and has no effect on images recorded with the device.
- Images in the monitor may be difficult to see under bright lighting.
- Do not apply pressure to the monitor, as this could cause damage or malfunction. Should the monitor break, care should be taken to avoid injury caused by broken glass and to prevent the liquid crystal from the display touching the skin or entering the eyes or mouth.

Notes About Smear

White or colored streaks may be visible when bright subjects are framed in the monitor. This phenomenon, known as "smear," occurs when extremely bright light strikes the image sensor; it is characteristic of image sensors and does not indicate a malfunction. Smear may also take the form of partial discoloration in the monitor during shooting. It does not appear in images saved with the camera except in the cases of movies. When recording movies, we recommend that you avoid bright subjects such as the sun, reflected sunlight, and electric lights.

The Battery

Precautions for Use

- Note that the battery may become hot after use.
- Do not use the battery at ambient temperatures below 0°C (32°F) or above 40°C (104°F) as this could cause damage or malfunction.
- If you notice any abnormalities such as excessive heat, smoke, or an unusual smell coming from the battery, immediately discontinue use and consult your retailer or Nikon-authorized service representative.
- After removing the battery from the camera or optional battery charger, put the battery in a plastic bag, etc. in order to insulate it.

Charging the Battery

Check the battery level before using the camera and replace or charge the battery if necessary.

- Charge the battery indoors with an ambient temperature of 5°C to 35°C (41°F to 95°F) before use.
- A high battery temperature may prevent the battery from charging properly or completely, and may reduce battery performance. Note that the battery may become hot after use; wait for the battery to cool before charging.
When charging the battery inserted into this camera using the Charging AC Adapter or a computer, the battery is not charged at battery temperatures below 0°C (32°F) or above 45°C (113°F).
- Do not continue charging once the battery is fully charged as this will result in reduced battery performance.
- The battery temperature may increase during charging. However, this is not a malfunction.



Carrying Spare Batteries

Whenever possible, carry fully charged spare batteries when taking pictures on important occasions.

Using the Battery When Cold

On cold days, the capacity of batteries tends to decrease. If an exhausted battery is used at a low temperature, the camera may not turn on. Keep spare batteries in a warm place and exchange as necessary. Once warmed, a cold battery may recover some of its charge.

Battery Terminals

Dirt on the battery terminals may prevent the camera from functioning. Should the battery terminals become dirty, wipe them off with a clean, dry cloth before use.

Charging an Exhausted Battery

Turning the camera on or off while an exhausted battery is inserted in the camera may result in reduced battery life. Charge the exhausted battery before use.

Storing the Battery

- Always remove the battery from the camera or optional battery charger when it is not being used. Minute amounts of current are drawn from the battery while it is in the camera, even when not in use. This may result in excessive battery drain and complete loss of function.
- Recharge the battery at least once every six months and completely exhaust it before returning it to storage.
- Put the battery in a plastic bag, etc. in order to insulate it and store it in a cool place. The battery should be stored in a dry location with an ambient temperature of 15°C to 25°C (59°F to 77°F). Do not store the battery in hot or extremely cold locations.

Battery Life

A marked drop in the time a fully charged battery retains its charge, when used at room temperature, indicates that the battery needs to be replaced. Purchase a new battery.

Recycling Used Batteries

Replace the battery when it no longer holds a charge. Used batteries are a valuable resource. Please recycle used batteries in accordance with local regulations.

The Charging AC Adapter

- The EH-72P/EH-72PCH Charging AC Adapter is for use only with compatible devices. Do not use with another make or model of device.
- Do not, under any circumstances, use another make or model of AC adapter other than the EH-72P/EH-72PCH Charging AC Adapter or USB-AC adapter. Failure to observe this precaution could result in overheating or in damage to the camera.
- The EH-72P/EH-72PCH is compatible with AC 100–240 V, 50/60 Hz electrical outlets. When using in other countries, use a plug adapter (commercially available) as necessary. For more information about plug adapters, consult your travel agency.



Memory Cards

Precautions for Use

- Use only Secure Digital memory cards (📖163).
- Be sure to follow the precautions described in the documentation included with the memory card.
- Do not put labels or stickers on memory cards.

Formatting

- Do not format the memory card using a computer.
- The first time you insert a memory card that has been used in another device into this camera, be sure to format it with this camera. We recommend formatting new memory cards with this camera before using them with this camera.
- **Note that formatting a memory card permanently deletes all images and other data on the memory card.** Be sure to make copies of any images you wish to keep before formatting the memory card.
- If the message **Card is not formatted. Format card?** is displayed when the camera is turned on, the memory card must be formatted. If there is data that you do not want to delete, select **No**. Copy the necessary data to a computer, etc. If you want to format the memory card, select **Yes**. The confirmation dialog will be displayed. To start formatting, press the  button.
- Do not perform the following during formatting, while data is being written to or deleted from the memory card, or during data transfer to a computer. Failure to observe this precaution could result in the loss of data or in damage to the camera or memory card:
 - Open the battery-chamber/memory card slot cover to remove/insert the battery or memory card.
 - Turn off the camera.
 - Disconnect the AC adapter.



Cleaning and Storage

Cleaning

Do not use alcohol, thinner, or other volatile chemicals.

Lens	Avoid touching glass parts with your fingers. Remove dust or lint with a blower (typically a small device with a rubber bulb attached to one end that is pumped to produce a stream of air out the other end). To remove fingerprints or other stains that cannot be removed with a blower, wipe the lens with a soft cloth, using a spiral motion that starts at the center of the lens and working toward the edges. If this fails, clean the lens using a cloth lightly dampened with commercial lens cleaner.
Monitor	Remove dust or lint with a blower. To remove fingerprints and other stains, clean the monitor with a soft, dry cloth, being careful not to apply pressure.
Body	Use a blower to remove dust, dirt, or sand, then wipe gently with a soft, dry cloth. After using the camera at the beach or other sandy or dusty environment, wipe off any sand, dust, or salt with a dry cloth lightly dampened with fresh water and dry thoroughly. Note that foreign matter inside the camera could cause damage not covered by the warranty.

Storage

Remove the battery if the camera will not be used for an extended period. To prevent mold or mildew, take the camera out of storage at least once a month. Turn the camera on and release the shutter a few times before putting the camera away again. Do not store the camera in any of the following locations:



- Places that are poorly ventilated or subject to humidity of over 60%
- Exposed to temperatures above 50°C (122°F) or below -10°C (14°F)
- Next to equipment that produces strong electromagnetic fields, such as televisions or radios

For storing the battery, follow the precautions in “The Battery” (📖140) in “Caring for the Product” (📖139).



Error Messages





Refer to the table below if an error message is displayed.

Display	Cause/Solution	
Battery temperature is elevated. The camera will turn off. The camera will turn off to prevent overheating.	The camera turns off automatically. Wait until the camera or battery temperature has cooled before resuming use.	-
Memory card is write protected.	The write-protect switch is in the "lock" position. Slide the write-protect switch to the "write" position.	-
This card cannot be used. This card cannot be read.	An error occurred while accessing the memory card. <ul style="list-style-type: none"> • Use an approved memory card. • Check that the terminals are clean. • Confirm that the memory card is correctly inserted. 	9, 163
Card is not formatted. Format card?	The memory card has not been formatted for use in the camera. Formatting deletes all data saved on the memory card. If you need to keep copies of any images, make sure to select No and save the copies to a computer or other medium before formatting the memory card. Select Yes and press the  button to format the memory card.	142
Out of memory.	Delete images or insert a new memory card.	9, 19







Display	Cause/Solution	
Image cannot be saved.	An error occurred while saving the image. Insert a new memory card or format the memory card or internal memory.	127
	The camera has run out of file numbers. Insert a new memory card or format the memory card or internal memory.	127
	There is insufficient space to save the copy. Delete images from the destination.	19
Image cannot be modified.	Check that the images can be edited.	68, 153
Cannot record movie.	A time-out error occurred while saving the movie on the memory card. Select a memory card with a faster write speed.	78, 163
Memory contains no images.	There are no images in the internal memory or on the memory card.	9
	<ul style="list-style-type: none"> Remove the memory card to play back images in the internal memory. To copy the images saved in the camera's internal memory to the memory card, press the MENU button to select Copy in the playback menu. 	113
File contains no image data.	The file was not created or edited with this camera.	-
This file cannot be played back.	The file cannot be viewed on this camera. View the file using a computer or the device used to create or edit this file.	
All images are hidden.	There are no images available for a slide show, etc.	111
This image cannot be deleted.	The image is protected. Disable protection.	112



Display	Cause/Solution	
No access.	The camera could not receive the signal from the smart device. Wirelessly connect the camera and smart device again. <ul style="list-style-type: none"> • Touch an NFC-compatible smart device to the camera. • Select Connect to smart device in the network menu. 	23, 117
Wi-Fi connection terminated.	The Wi-Fi connection is terminated in the following situations: <ul style="list-style-type: none"> • Poor connectivity. • The battery level is low. • A cable or a memory card is inserted or removed. Use a sufficiently charged battery, disconnect the TV, computer or printer and establish the wireless connection again.	12, 117
Turn the camera off and then on again.	If the error persists, contact your retailer or Nikon-authorized service representative.	148
Communications error	An error occurred while communicating with the printer. Turn the camera off and reconnect the USB cable.	83
System error	An error occurred in the camera's internal circuitry. Turn the camera off, remove and reinsert the battery, and turn the camera on. If the error persists, contact your retailer or Nikon-authorized service representative.	148
Printer error: check printer status.	After solving the problem, select Resume and press the  button to resume printing.*	–
Printer error: check paper.	Load the specified size of paper, select Resume , and press the  button to resume printing.*	–
Printer error: paper jam.	Remove the jammed paper, select Resume , and press the  button to resume printing.*	–



Display	Cause/Solution	
Printer error: out of paper.	Load the specified size of paper, select Resume , and press the  button to resume printing.*	-
Printer error: check ink.	There is a problem with the printer's ink. Check the ink, select Resume , and press the  button to resume printing.*	-
Printer error: out of ink.	Replace the ink cartridge, select Resume , and press the  button to resume printing.*	-
Printer error: file corrupt.	There is a problem with the image file to be printed. Select Cancel and press the  button to cancel printing.	-

* See the documentation provided with your printer for further guidance and information.





Troubleshooting

If the camera fails to function as expected, check the list of common problems below before consulting your retailer or Nikon-authorized service representative.

Power, Display, Settings Issues

Problem	Cause/Solution	
The camera is on but does not respond.	<ul style="list-style-type: none">• Wait for recording to end.• If the problem persists, turn the camera off. If the camera does not turn off, remove and reinsert the battery or batteries or, if you are using an AC adapter, disconnect and reconnect the AC adapter. Note that although any data currently being recorded will be lost, data that have already been recorded will not be affected by removing or disconnecting the power source.	–
The camera cannot be turned on.	The battery is exhausted.	9, 10, 141
The camera turns off without warning.	<ul style="list-style-type: none">• The camera automatically turns off to save power (auto off function).• The camera and battery may not work properly at low temperatures.• The inside of the camera has become hot. Leave the camera off until the inside of the camera has cooled, and then try turning it on again.	17 140 –
The monitor is blank.	<ul style="list-style-type: none">• The camera is off.• The camera automatically turns off to save power (auto off function).• The flash lamp flashes while the flash is charging. Wait until charging is complete.• The camera is connected to a TV or computer.• The camera and smart device are connected using a Wi-Fi connection and the camera is being operated by remote control.	12 17 – – –
The camera becomes hot.	The camera may become hot when used for an extended period of time to shoot movies or when used in a hot environment; this is not a malfunction.	–





Problem	Cause/Solution	
The battery inserted in the camera cannot be charged.	<ul style="list-style-type: none"> • Confirm all connections. • When connected to a computer, the camera may not charge for any of the reasons described below. <ul style="list-style-type: none"> - Off is selected for Charge by computer in the setup menu. - Battery charging stops if the camera is turned off. - Battery charging is not possible if the camera's display language and date and time have not been set, or the date and time were reset after the camera's clock battery was exhausted. Use the Charging AC Adapter to charge the battery. - Battery charging may stop when the computer enters sleep mode. - Depending on the computer specifications, settings, and status, battery charging may not be possible. 	10 91, 131 – 12 – –
The monitor is hard to see.	<ul style="list-style-type: none"> • The surrounding area is too bright. <ul style="list-style-type: none"> - Move to a darker place. • Adjust the screen brightness. 	121
 flashes on the screen. Date and time of recording are not correct.	<ul style="list-style-type: none"> • If the camera clock has not been set,  flashes on the shooting screen, and images and movies saved before the clock is set are dated "00/00/0000 00:00" and "01/01/2016 00:00" respectively. Set the correct time and date for Time zone and date in the setup menu. • The camera clock is not as accurate as ordinary watches or clocks. Periodically compare the time of the camera clock with that of a more accurate timepiece, and reset as required. 	5, 119
No indicators displayed on the screen.	Hide info is selected for Photo info in Monitor settings in the setup menu.	121
Date stamp not available.	Time zone and date has not been set in the setup menu.	119
Date not stamped on images even when Date stamp is enabled.	<ul style="list-style-type: none"> • The current shooting mode does not support Date stamp. • The date cannot be stamped on movies. 	123





Problem	Cause/Solution	
Screen for setting time zone and date is displayed when the camera is turned on.	The clock battery is exhausted; all settings were restored to their default values. Configure the camera settings again. <ul style="list-style-type: none"> The internal clock battery is used to power the camera clock and to retain certain settings. Charging time of the clock battery takes about 10 hours when you insert the batteries into the camera or connect the AC adapter (available separately) to the camera, and the clock battery operates for several days even after the camera battery is removed. 	–
The camera settings reset.		
The camera makes sound.	When Autofocus mode is set to Full-time AF or while in some shooting modes, the camera may produce an audible focusing sound.	31, 107, 115







Shooting Issues

Problem	Cause/Solution	
Cannot switch to shooting mode.	The camera cannot be switched to shooting mode while connected to a power outlet via the Charging AC Adapter.	81
Cannot take pictures or record movies.	<ul style="list-style-type: none"> When the camera is in playback mode, press the  button, shutter-release button, or  button. When menus are displayed, press the MENU button. The flash is charging while the flash lamp is flashing. The battery is exhausted. 	2, 18 91 50 9, 10, 141
The camera cannot focus.	<ul style="list-style-type: none"> The subject is too close. Try shooting using scene auto selector mode, Close-up scene mode, or macro mode. The subject is hard to focus on. Set AF assist in the setup menu to Auto. Turn the camera off and then on again. 	31, 34, 36, 49, 54 59 125 –
Images are blurred.	<ul style="list-style-type: none"> Use the flash. Increase the ISO sensitivity value. Use Photo VR when taking still images, and use Movie VR when recording movies. Use a tripod to stabilize the camera (using the self-timer at the same time is more effective). 	50 103 116, 124 52



Problem	Cause/Solution	
Streaks of light or partial discoloration are visible on the screen.	Smear may occur when extremely bright light strikes the image sensor. When recording movies, avoiding bright objects, such as the sun, reflections of the sun, and electric lights is recommended.	78, 140
Bright specks appear in images captured with flash.	Flash is reflecting off particles in the air. Set the flash mode to  (off).	50
Flash does not fire.	<ul style="list-style-type: none"> • The flash mode is set to  (off). • A scene mode that restricts the flash is selected. • A function that restricts the flash is enabled. 	50 61 63
Optical zoom cannot be used.	Optical zoom cannot be used while recording movies.	78
Digital zoom cannot be used.	<ul style="list-style-type: none"> • Digital zoom is set to Off in the setup menu. • Digital zoom cannot be used with certain shooting modes or when using certain settings in other functions. 	125 63, 125
Image mode not available.	A function that restricts Image mode is enabled.	63
No sound when the shutter is released.	Off is selected for Shutter sound in Sound settings in the setup menu. No sound is produced with some shooting modes and settings, even when On is selected.	126
AF-assist illuminator does not light.	Off is selected for AF assist in the setup menu. AF-assist illuminator may not light depending on the position of the focus area or the current scene mode, even when Auto is selected.	125
Images appear smeared.	The lens is dirty. Clean the lens.	143
Colors are unnatural.	White balance or hue is not adjusted properly.	36, 100
Randomly spaced bright pixels ("noise") appear in image.	The subject is dark and the shutter speed is too slow, or ISO sensitivity is too high. Noise can be reduced by: <ul style="list-style-type: none"> • Using the flash • Specifying a lower ISO sensitivity setting 	50 103



Problem	Cause/Solution	
Randomly spaced bright pixels ("noise") appear in movies.	When recording movies in dim lighting, the image may contain noise. This occurs when the ISO sensitivity increases, and it does not indicate a malfunction.	–
Images are too dark (underexposed).	<ul style="list-style-type: none"> • The flash mode is set to  (off). • The flash window is blocked. • The subject is beyond the range of the flash. • Adjust exposure compensation. • Increase ISO sensitivity. • The subject is backlit. Select Backlighting scene mode or set the flash mode setting to  (fill flash). 	50 15 160 55 103 37, 50
Images are too bright (overexposed).	Adjust exposure compensation.	55
Unexpected results when flash set to  (auto with red-eye reduction).	Use any shooting mode other than Night portrait , and change the flash mode to any setting other than  (auto with red-eye reduction) and try taking the picture again.	50, 61
Skin tones are not softened.	<ul style="list-style-type: none"> • Under some shooting conditions, facial skin tones may not be softened. • For images containing four or more faces, try using the Skin softening effect in Glamour retouch in the playback menu. 	38 71
Saving images takes time.	<p>It may take more time to save images in the following situations:</p> <ul style="list-style-type: none"> • When the noise reduction function is in operation, such as when shooting in a dark environment • When the flash mode is set to  (auto with red-eye reduction) • When the skin softening function is applied while shooting • When using continuous shooting mode 	– 51 38, 108 102
Colored circles or light streaks appear on the screen or images.	When shooting with backlighting or when a very strong light source (such as sunlight) is in the frame, colored circles or light streaks (ghosting) may occur. Change the position of the light source, or frame the image so that the light source does not enter the frame, and try again.	–





Playback Issues



Problem	Cause/Solution	
File cannot be played back.	<ul style="list-style-type: none"> • This camera may not be able to play back images saved with another make or model of digital camera. • This camera cannot play back movies recorded with another make or model of digital camera. • This camera may not be able to play back data edited on a computer. 	–
Cannot zoom in on image.	<ul style="list-style-type: none"> • Playback zoom cannot be used with movies. • For small images, the magnification rate displayed on the screen may not be compatible with the actual magnification rate. • This camera may not be able to zoom in on images captured with another make or model of digital camera. 	–
Cannot edit image.	<ul style="list-style-type: none"> • Some images cannot be edited. Images that have already been edited may not be edited again. • There is not enough free space on the memory card or in the internal memory. • This camera is unable to edit images captured with other cameras. • Editing functions used for images are not available for movies. 	41, 68 – – –



External Device Issues

Problem	Cause/Solution	
Cannot establish a wireless connection with a smart device.*	<ul style="list-style-type: none"> • When establishing a wireless connection for the first time, see “Connecting to a Smart Device (SnapBridge)”. 	21
	<ul style="list-style-type: none"> • See also “If the Connection Is Unsuccessful”. 	26
	<ul style="list-style-type: none"> • When a wireless connection is already established, perform the following operations. <ul style="list-style-type: none"> - Turn off the camera and then turn on the camera again. 	29
	<ul style="list-style-type: none"> - Launch the SnapBridge app again. 	-
	<ul style="list-style-type: none"> - Disconnect the connection once and then establish the connection again. 	29
	<ul style="list-style-type: none"> • Check the Network menu settings on the camera. 	117
	<ul style="list-style-type: none"> - Set Airplane mode to Off. 	
	<ul style="list-style-type: none"> - Set Bluetooth → Connection to Enable. 	
	<ul style="list-style-type: none"> • If two or more smart devices have been registered in the camera, select the smart device that you want to connect to in Network menu → Bluetooth → Paired devices in the camera. If two or more cameras have been registered in the SnapBridge app, switch the camera that you want to connect to from the app. 	117
	<ul style="list-style-type: none"> • Use a sufficiently charged battery. 	-
<ul style="list-style-type: none"> • Insert a memory card with sufficient free space into the camera. 	9	
<ul style="list-style-type: none"> • Disconnect the USB cable. 	81	
<ul style="list-style-type: none"> • Enable Bluetooth, Wi-Fi, and the location data functions on the smart device. 	-	
<ul style="list-style-type: none"> • Enable Auto link in the  tab → Auto link options in the SnapBridge app. If it is disabled, Download pictures and Remote photography can be used, but images cannot be uploaded automatically. 	-	



Problem	Cause/Solution	
<p>Cannot upload images to a smart device that has a wireless connection established with the SnapBridge app.*</p>	<ul style="list-style-type: none"> • Perform the operations described below when uploading automatically. <ul style="list-style-type: none"> - On the camera, set Network menu → Send while shooting → Still images → Yes. - Enable Auto link in the  tab → Auto link options in the SnapBridge app. - Enable Auto download in the  tab → Auto link options in the SnapBridge app. - If Network menu → Bluetooth → Send while off on the camera is set to Off, turn on the camera or set it to On. • You may not be able to upload images or uploading may be canceled while the camera is being operated. • You may not be able to upload images or uploading may be canceled depending on the state of the camera. • See also "If Images Cannot Be Uploaded Successfully". 	<p>117</p> <p>–</p> <p>–</p> <p>117</p> <p>–</p> <p>29</p> <p>29</p>
<p>Cannot perform remote photography from a smart device that has a wireless connection established with the SnapBridge app.*</p>	<ul style="list-style-type: none"> • If the internal memory or memory card does not have sufficient free space, you cannot perform remote photography. Delete unnecessary images or insert a memory card with sufficient free space into the camera. • You may not be able to perform remote photography while the camera is being operated. • You may not be able to perform remote photography depending on the state of the camera. 	<p>–</p> <p>–</p> <p>29</p>
<p>Cannot download still images at the original size by using the SnapBridge app.*</p>	<p>For Send while shooting and Mark for upload in the camera, the image size that can be uploaded is restricted to 2 megapixels. Use Download pictures in the SnapBridge app to upload the original size of still images.</p>	<p>–</p>
<p>Images saved in the camera are not displayed on a connected smart device or computer.</p>	<p>If the number of images saved on a memory card in the camera exceeds 10,000, images captured thereafter may not be displayed in a connected device.</p> <ul style="list-style-type: none"> • Reduce the number of images saved on the memory card. Copy the necessary images to a computer, etc. 	<p>–</p>
<p>Images are not displayed on TV.</p>	<ul style="list-style-type: none"> • Video mode is not correctly set in the setup menu. • The memory card contains no images. • Remove the memory card to play back images in the internal memory. 	<p>91, 130</p> <p>–</p> <p>9</p>



Problem	Cause/Solution	
Nikon Transfer 2 does not start when the camera is connected to a computer.	<ul style="list-style-type: none"> • The camera is off. • The battery is exhausted. • The USB cable is not correctly connected. • The camera is not recognized by the computer. • The computer is not set to start Nikon Transfer 2 automatically. For more information about Nikon Transfer 2, refer to help information contained in ViewNX-i. 	<p>– 81, 131 81, 87 – –</p>
The PictBridge startup screen is not displayed when the camera is connected to a printer.	With some PictBridge-compatible printers, the PictBridge startup screen may not be displayed and it may be impossible to print images when Auto is selected for Charge by computer in the setup menu. Set Charge by computer to Off and reconnect the camera to the printer.	91, 131
Images to be printed are not displayed.	<ul style="list-style-type: none"> • The memory card contains no images. • Remove the memory card to print images in the internal memory. 	<p>– 9</p>
Cannot select paper size with the camera.	<p>The camera cannot be used to select the paper size in the following situations, even when printing from a PictBridge-compatible printer. Use the printer to select the paper size.</p> <ul style="list-style-type: none"> • The printer does not support the paper sizes specified by the camera. • The printer automatically selects the paper size. 	–

* See "Connecting to a Smart Device (SnapBridge)" ()21) and the SnapBridge online help.



File Names

Images or movies are assigned file names as follows.

File name: DSCN 0001 .JPG

(1) (2) (3)

(1) Identifier	Not shown on the screen of the camera. <ul style="list-style-type: none">• DSCN: Original still images, movies• SSCN: Small picture copies• RSCN: Cropped copies• FSCN: Images created by an image editing function other than crop and small picture
(2) File number	Assigned in ascending order, starting with "0001" and ending with "9999."
(3) Extension	Indicates file format. <ul style="list-style-type: none">• .JPG: Still images• .AVI: Movies

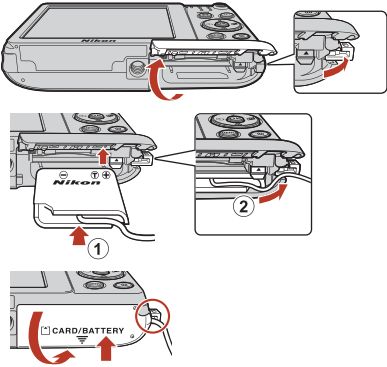

Optional Accessories

Battery charger	MH-66 Battery Charger Charging time is about 1 hour and 50 minutes for a fully exhausted battery.
AC adapter	EH-62G AC Adapter (connect as shown)  <p>Make sure that the power connector cable is fully inserted in the power connector slot before inserting the AC adapter into the battery chamber. In addition, make sure that the power connector cable is fully inserted in the battery chamber slot before closing the battery-chamber/memory card slot cover. If part of the cable protrudes from the slots, the cover or cable may be damaged when the cover is closed.</p>
Audio video cable	EG-CP14 Audio Video Cable

Availability may vary with country or region.
See our website or brochures for the latest information.



Specifications

Nikon COOLPIX A300 Digital Camera

Type	Compact digital camera
Number of effective pixels	20.1 million (Image processing may reduce the number of effective pixels.)
Image sensor	$1/2.3$ -in. type CCD; approx. 20.48 million total pixels
Lens	NIKKOR lens with 8 \times optical zoom
Focal length	4.5–36.0 mm (angle of view equivalent to that of 25–200 mm lens in 35mm [135] format)
f/-number	f/3.7–6.6
Construction	8 elements in 7 groups
Digital zoom magnification	Up to 4 \times (angle of view equivalent to that of approx. 800 mm lens in 35mm [135] format)
Vibration reduction	Lens shift (still images) Lens shift and electronic VR (movies)
Autofocus (AF)	Contrast-detect AF
Focus range	<ul style="list-style-type: none">• [W]: Approx. 50 cm (1 ft 8 in.)–∞,• [T]: Approx. 1.5 m (5 ft)–∞• Macro mode: Approx. 2 cm (0.8 in.)–∞ (wide-angle position) (All distances measured from center of front surface of lens)
Focus-area selection	Face priority, center, manual with 99 focus areas, subject tracking, target finding AF
Monitor	6.7 cm (2.7-in.), approx. 230k-dot, TFT LCD with anti-reflection coating and 5-level brightness adjustment
Frame coverage (shooting mode)	Approx. 99% horizontal and vertical (compared to actual picture)
Frame coverage (playback mode)	Approx. 99% horizontal and vertical (compared to actual picture)
Storage	
Media	Internal memory (approx. 19 MB), SD/SDHC/SDXC memory card
File system	DCF and Exif 2.3 compliant
File formats	Still images: JPEG Movies: AVI (Motion-JPEG compliant)



Image size (pixels)	<ul style="list-style-type: none"> • 20M (High) [5152 × 3864★] • 20M [5152 × 3864] • 10M [3648 × 2736] • 4M [2272 × 1704] • 2M [1600 × 1200] • VGA [640 × 480] • 16:9 (14M) [5120 × 2880] • 1:1 [3864 × 3864]
ISO sensitivity (Standard output sensitivity)	<ul style="list-style-type: none"> • ISO 80–1600 • ISO 3200 (available when using Auto mode)
Exposure	
Metering mode	Matrix, center-weighted (digital zoom less than 2x), spot (digital zoom 2x or more)
Exposure control	Programmed auto exposure and exposure compensation (–2.0 – +2.0 EV in steps of $\frac{1}{3}$ EV)
Shutter	Mechanical and CCD electronic shutter
Speed	<ul style="list-style-type: none"> • $\frac{1}{1500}$–1 s • 4 s (Fireworks show scene mode)
Aperture	Electromagnetic ND filter (–3 AV) selection
Range	2 steps (f/3.7 and f/10.5 [W])
Self-timer	<ul style="list-style-type: none"> • 10 s, 2 s • 5 s (Self-portrait timer)
Flash	
Range (approx.) (ISO sensitivity: Auto)	[W]: 0.5–2.8 m (1 ft 8 in.–9 ft 2 in.) [T]: 1.5 m (4 ft 11 in.)
Flash control	TTL auto flash with monitor preflashes
Interface	
USB connector	Hi-Speed USB <ul style="list-style-type: none"> • Supports Direct Print (PictBridge) • Also used as audio/video output connector (NTSC or PAL can be selected for video output.)



Wi-Fi (Wireless LAN)	
Standards	IEEE 802.11b/g (standard wireless LAN protocol)
Frequency	2412–2462 MHz (1-11 channels)
Authentication	Open system, WPA2-PSK
Bluetooth	
Communication protocols	Bluetooth Specification Version 4.1
Supported languages	Arabic, Bengali, Bulgarian, Chinese (Simplified and Traditional), Czech, Danish, Dutch, English, Finnish, French, German, Greek, Hindi, Hungarian, Indonesian, Italian, Japanese, Korean, Marathi, Norwegian, Persian, Polish, Portuguese (European and Brazilian), Romanian, Russian, Serbian, Spanish, Swedish, Tamil, Telugu, Thai, Turkish, Ukrainian, Vietnamese
Power sources	One EN-EL19 Rechargeable Li-ion Battery (included) EH-62G AC Adapter (available separately)
Charging time	Approx. 2 h 40 min (when using EH-72P/EH-72PCH Charging AC Adapter and when no charge remains)
Battery life¹	
Still images	Approx. 240 shots when using EN-EL19
Movies (actual battery life for recording) ²	Approx. 45 min when using EN-EL19
Tripod socket	1/4 (ISO 1222)
Dimensions (W × H × D)	Approx. 95.9 × 58.0 × 20.1 mm (3.8 × 2.3 × 0.8 in.) (excluding projections)
Weight	Approx. 119 g (4.2 oz) (including battery and memory card)
Operating environment	
Temperature	0°C–40°C (32°F–104°F)
Humidity	85% or less (no condensation)

- All measurements are performed in conformity with Camera and Imaging Products Association (CIPA) standards or guidelines.

¹ Battery life does not reflect the use of SnapBridge and may vary with the conditions of use, including temperature, the interval between shots, and the length of time that menus and images are displayed.

² Individual movie files cannot exceed 2 GB in size or 29 minutes in length. Recording may end before this limit is reached if camera temperature becomes elevated.



EN-EL19 Rechargeable Li-ion Battery

Type	Rechargeable lithium-ion battery
Rated capacity	DC 3.7 V, 700 mAh
Operating temperature	0°C–40°C (32°F–104°F)
Dimensions (W × H × D)	Approx. 31.5 × 39.5 × 6 mm (1.3 × 1.6 × 0.3 in.)
Weight	Approx. 14.5 g (0.5 oz)

EH-72P/EH-72PCH Charging AC Adapter

Rated input	AC 100–240 V, 50/60 Hz, 0.07–0.04 A
Rated output	DC 5.0 V, 550 mA
Operating temperature	0°C–40°C (32°F–104°F)
Dimensions (W × H × D)	Approx. 55 × 22 × 54 mm (2.2 × 0.9 × 2.2 in.) (excluding plug adapter) For Argentina: Approx. 55 × 63 × 59 mm (2.2 × 2.5 × 2.4 in.) For India: Approx. 55 × 63.5 × 59 mm For Korea: Approx. 55 × 67 × 59 mm
Weight	Approx. 46 g (1.7 oz) (excluding plug adapter) For Argentina, India, and Korea: Approx. 71 g (2.6 oz)

The symbols on this product represent the following:

~ AC, ≡ DC,  Class II equipment (The construction of the product is double-insulated.)

- Nikon will not be held liable for any errors this manual may contain.
- The appearance of this product and its specifications are subject to change without notice.



Memory Cards That Can Be Used

The camera supports SD, SDHC, and SDXC memory cards.

- Memory cards with an SD Speed Class rating of 6 or faster are recommended for recording movies. When using a memory card with a lower Speed Class rating, movie recording may stop unexpectedly.
- If you use a card reader, make sure that it is compatible with your memory card.
- Contact the manufacturer for information on features, operation, and limitations on use.

Trademark Information

- Windows is either a registered trademark or trademark of Microsoft Corporation in the United States and/or other countries.
- The *Bluetooth*® word mark and logos are registered trademarks owned by Bluetooth SIG, Inc. and any use of such marks by Nikon Corporation is under license.
- Apple®, App Store®, the Apple logos, Mac, OS X, macOS, iPhone®, iPad®, iPod touch® and iBooks are trademarks or registered trademarks of Apple Inc., in the U.S. and other countries.
- Android and Google Play are trademarks or registered trademarks of Google Inc. The Android robot is reproduced or modified from work created and shared by Google and used according to terms described in the Creative Commons 3.0 Attribution License.
- iOS is a trademark or registered trademark of Cisco Systems, Inc., in the United States and/or other countries and is used under license.
- Adobe, the Adobe logo, and Reader are either trademarks or registered trademarks of Adobe Systems Incorporated in the United States and/or other countries.
- SDXC, SDHC, and SD Logos are trademarks of SD-3C, LLC.



- PictBridge is a trademark.
- Wi-Fi and the Wi-Fi logo are trademarks or registered trademarks of the Wi-Fi Alliance.
- The N-Mark is a trademark or registered trademark of NFC Forum, Inc. in the United States and in other countries.



- All other trade names mentioned in this manual or the other documentation provided with your Nikon product are the trademarks or registered trademarks of their respective holders.

“Made for iPod,” “Made for iPhone,” and “Made for iPad” mean that an electronic accessory has been designed to connect specifically to iPod, iPhone, or iPad, respectively, and has been certified by the developer to meet Apple performance standards. Apple is not responsible for the operation of this device or its compliance with safety and regulatory standards. Please note that the use of this accessory with iPod, iPhone, or iPad may affect wireless performance.

AVC Patent Portfolio License

This product is licensed under the AVC Patent Portfolio License for the personal and non-commercial use of a consumer to (i) encode video in compliance with the AVC standard (“AVC video”) and/or (ii) decode AVC video that was encoded by a consumer engaged in a personal and non-commercial activity and/or was obtained from a video provider licensed to provide AVC video. No license is granted or shall be implied for any other use. Additional information may be obtained from MPEG LA, L.L.C.

See <http://www.mpegla.com>.

FreeType License (FreeType2)

- Portions of this software are copyright © 2012 The FreeType Project (<http://www.freetype.org>). All rights reserved.

MIT License (HarfBuzz)

- Portions of this software are copyright © 2016 The HarfBuzz Project (<http://www.freedesktop.org/wiki/Software/HarfBuzz>). All rights reserved.





Index

Symbols

 Scene auto selector mode 31, 34

 Scene mode 31, 35

 Special effects mode 31, 42

 Smart portrait mode 31, 44

 Auto mode 31, 32

 Playback mode 18

 List by date mode 67

 Setup menu 91, 119

 Network menu 91, 117

T (Telephoto) 18, 56



W (Wide-angle) 18, 56

 Playback zoom 18, 65

 Thumbnail playback 18, 66

 Shooting mode button 3, 31

 Playback button 3, 18

 ( movie-record) button 3, 17

 Apply selection button 3

MENU Menu button 3, 91

 Delete button 3, 19

 N-Mark 3, 23

 Flash mode 49, 50

 Self-timer 49, 52

 Macro mode 49, 54

 Exposure compensation 49, 55

AE/AF-L 40

A

AC adapter 81, 158

AF area mode 104

AF assist 2, 125

Airplane mode 117

App 22

Audio video cable 81, 82, 158

Auto flash 51

Auto mode 31, 32

Auto off 17, 126

Auto with red-eye reduction 51

Autofocus 78, 107, 115

Autofocus mode 107, 115

B

Backlighting  35, 37

Battery 9, 10, 162

Battery chamber 158

Battery charger 11, 158

Battery latch 9

Battery level indicator 16

Battery-chamber/memory card slot cover 3

Beach  35

Blink proof 109

Bluetooth 117

Brightness 121

Built-in microphone 2

Button sound 126

C

Calendar Display 66

Charge by computer 131

Charge lamp 3

Charging 10, 131

Charging AC Adapter 10, 162

Close-up  35, 36

Cloudy 100

Compression ratio 98

Computer 81, 87







Conformity Marking 132

Connect to smart device 117







Connector cover 2, 81

Continuous 102



Copying images.....	113	F-number.....	57
Copyright information.....	129	Focus.....	104
Creative Slider.....	32	Focus area.....	57
Crop.....	74	Focus indicator.....	4, 16
Cross process 	42	Focus lock.....	60
Current settings.....	117	Food 	35, 36
D		Format internal memory.....	127
Date and time.....	12, 119	Format memory cards.....	9, 127
Date format.....	119	Formatting.....	9, 127
Date stamp.....	123	Full-frame playback.....	65
Daylight.....	100	Full-time AF.....	107, 115
Daylight saving time.....	119	Functions that cannot be used simultaneously.....	63
Delete.....	19	G	
Digital zoom.....	56, 125	Glamour retouch.....	44, 71
Direct print.....	83	H	
D-Lighting.....	69	Help display.....	31, 121
Dusk/dawn 	35	High-contrast monochrome 	42
Dynamic Fine Zoom.....	56		
E		I	
Editing images.....	68	Image comment.....	128
EH-72P/EH-72PCH.....	162	Image mode.....	98
EN-EL19.....	162	Image quality.....	98
Exposure compensation.....	55	Image review.....	121
Eyelet for camera strap.....	2	Image size.....	98
E		Incandescent.....	100
Face detection.....	58	Internal memory.....	9
Face priority.....	104	Internal memory indicator.....	4, 6
File names.....	157	Interval.....	108
Fill flash.....	51	ISO sensitivity.....	103
Fireworks show 	35, 37	L	
Firmware version.....	132	Landscape 	35
Fixed range auto.....	103	Language.....	128
Flash.....	2, 50	Lens.....	2, 159
Flash lamp.....	3, 50	Lens cover.....	2
Flash mode.....	50, 51	List by date mode.....	67
Flash off.....	51	Location data.....	130
Fluorescent.....	100		



M	
Macro mode	54
Mark for upload	110
Memory card.....	142, 163
Memory card slot.....	9
Monitor.....	3, 4, 143
Monitor settings.....	121
Movie menu	91, 114
Movie options	114
Movie playback.....	17, 79
Movie recording.....	17, 76
Movie VR.....	116
Multi selector	3, 91
N	
Network menu.....	91, 117
Night landscape 	35, 36
Night portrait 	35
Nostalgic sepia SE	42
Number of exposures remaining	16, 99
Number of shots.....	108
Q	
Optical zoom	56
Optional accessories	158
P	
Panorama assist playback.....	41
Panorama assist 	35, 39
Paper size	84, 85
Party/indoor 	35, 36
Pet portrait auto release	37
Pet portrait 	35, 37
Photo info	121
Photo VR	124
PictBridge.....	81, 83
Playback.....	18
Playback menu	91, 110
Playback mode	18
Playback zoom	18, 65
Pop POP	42
Portrait 	35
Power switch.....	2, 12
Power-on lamp	2
Preset manual.....	101
Pressing halfway	57
Print.....	81, 84, 85
Printer	81, 83
Protect.....	112
Q	
Quick effects.....	68
Quick retouch.....	69
R	
Rechargeable Li-ion battery	162
Recorded location data indicator	6, 130
Red-eye correction	70
Remaining movie recording time	76, 77
Reset all.....	132
Restore default settings.....	117
Rotate image.....	112
S	
Scene mode.....	35
SD memory card.....	142, 163
Selective color 	42
Self-collage	47
Self-portrait timer	37, 52
Self-timer	52
Self-timer lamp	2, 53
Send while shooting	117
Setup menu	91, 119
Shooting	15, 31
Shooting menu.....	91, 98
Shooting mode	31
Shutter sound.....	108, 126



Shutter speed	57	V	
Shutter-release button	2	Video mode	130
Single	102	ViewNX-i	87
Single AF	107, 115	Volume	79
Skin softening	38	W	
Slide show	111	White balance	100
Slow sync	51	Wide-angle	56
Small picture	73	Wi-Fi	117
Smart portrait menu	91, 108	Wind noise reduction	116
Smart portrait mode	44	Z	
Smile timer	46	Zoom control	2, 56
SnapBridge app	22	Zooming in/out	56
Snow 	35		
Soft SO	42		
Sound settings	126		
Speaker	3		
Special effects mode	42		
Sports 	35, 36		
Strap	8		
Subject tracking	105, 106		
Sunset 	35		
I			
Target finding AF	57, 105		
Telephoto	56		
Televisions	81, 82		
Thumbnail playback	18, 66		
Time difference	119		
Time zone	119		
Time zone and date	119		
Toy camera effect 1 	42		
Toy camera effect 2 	42		
Tripod socket	3, 161		
U			
USB cable	10, 81, 83, 87		
USB/audio/video output connector	2		



No reproduction in any form of this manual, in whole or in part (except for brief quotation in critical articles or reviews), may be made without written authorization from NIKON CORPORATION.

NIKON CORPORATION

© 2016 Nikon Corporation



YP7J04(11)
6MN67711-04