



EN

USER MANUAL

REFRIGERATOR

Compact



Please read the Manual carefully before use.
The Manual shall be kept in good custody for later reference

MODEL: WHS-87LW1
WHS-87LB1
WHS-87LSS1

version:001

www.midea.com

Table of Contents

Important Safety Instructions.....	2
Installation.....	4
Door Reversal Instructions.....	5
Temperature Control.....	7
Refrigerator Components.....	8
Before You Call.....	9

SERIAL/MODEL NUMBERS AND IMPORTANT SAFETY INSTRUCTIONS

Read and Save These Instructions

This Instruction Manual provides specific operating instructions for your model. Use your refrigerator only as instructed in this guide. These instructions are not meant to cover every possible condition and situation that may occur. Common sense and caution must be practiced when installing, operating and maintaining any appliance.

Record Your Model and Serial Numbers

Record the model and serial numbers in the space provided below. The serial plate is located on the upper left wall inside the refrigerator.

Model Number: _____

Serial Number: _____

Purchase Date: _____

WARNING

Please read all instructions before using this refrigerator.

Definitions

 This is the safety alert symbol. It is used to alert you to potential personal injury hazards. Obey all safety messages that follow this symbol to avoid possible injury or death.

DANGER

DANGER indicates an imminently hazardous situation which, if not avoided, will result in death or serious injury.

WARNING

WARNING indicates a potentially hazardous situation which, if not avoided, could result in death or serious injury.

CAUTION

CAUTION indicates a potentially hazardous situation which, if not avoided, may result in minor or moderate injury.

IMPORTANT

IMPORTANT indicates installation, operation or maintenance information which is important but not hazard-related.

WARNING

For Your Safety

Do not store or use gasoline, or other flammable vapors and liquids, in the vicinity of this or any other appliance. Read product labels for flammability and other warnings.

WARNING

Electrical Information

- **The refrigerator must be plugged into its own dedicated 115V, 60Hz, 15 Amp, AC only electrical outlet.** The power cord of the appliance is equipped with a 3-prong grounding plug for your protection against electrical shock hazards. It must be plugged directly into a properly grounded 3-prong receptacle. The receptacle must be installed in accordance with local codes and ordinances. Consult a qualified electrician. Avoid connecting the refrigerator to a ground fault interruptor (GFI) circuit. **Do not use an extension cord or adaptor plug.**
- If the power cord is damaged, it should be replaced by an authorized service technician to prevent any risk.
- Never unplug the refrigerator by pulling on the power cord. Always grip the plug firmly, and pull straight out from the receptacle to prevent damaging the power cord.
- Unplug the refrigerator before cleaning and before replacing a light bulb to avoid electrical shock.
- Performance may be affected if the voltage varies by 10% or more. Operating the refrigerator with insufficient power can damage the compressor. Such damage is not covered under your warranty.
- Do not plug the unit into an electrical outlet controlled by a wall switch or pull cord to prevent the refrigerator from being turned off accidentally.

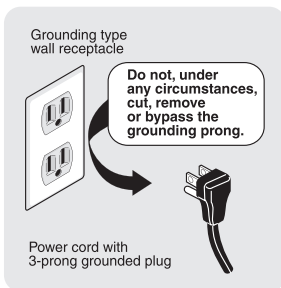

WARNING

Child Safety

- Destroy carton, plastic bags and any exterior wrapping material immediately after the refrigerator is unpacked. Children should never play with these items. Cartons covered with rugs, bedspreads, plastic sheets or stretch wrap may become airtight chambers and can quickly cause suffocation.
- Remove all staples from the carton. Staples can cause severe cuts and destroy finishes if they come in contact with other appliances or furniture.
- Keep all empty, discarded refrigerators out of the reach of children.
- Remove the door(s) of any appliance that is not in use, even if it is being discarded.

WARNING

Proper Disposal of Your Refrigerator Risk of Child Entrapment

Child entrapment and suffocation are not problems of the past. Junked or abandoned refrigerators are still dangerous – even if they will sit for “just a few days.” If you are getting rid of your old refrigerator, please follow the instructions below to help prevent accidents.

We strongly encourage responsible appliance recycling/disposal methods. Check with your utility company or visit www.recyclemyoldfridge.com for more information about recycling your old refrigerator.

Before you throw away your old refrigerator:

- Remove the doors.
- Leave the shelves in place so children may not easily climb inside.
- Have the refrigerator removed by a qualified service technician.

INSTALLATION

This use and care guide provides general operating instructions for your model. Use the refrigerator only as instructed in this manual. **Before starting the refrigerator, follow these important first steps.**

Location

- Choose a place that is near a grounded electrical outlet. **Do Not** use an extension cord or an adaptor plug.
- To operate the most efficiently, the refrigerator should be located where surrounding temperatures will not drop below 10°F (-12°C) or exceed 110°F (43°C). The Freeze Control Feature is designed to automatically maintain the selected interior refrigerator temperature within these boundaries.
- Allow space around the unit for good air circulation. Leave a 4-inch (101.6mm) space on the back and 3 inches (76.2mm) on the sides of the refrigerator for adequate circulation.

NOTE

The exterior walls of the refrigerator may become quite warm as the compressor works to transfer heat from the inside. Temperatures as much as 30°F warmer than room temperature can be expected. For this reason, it is particularly important in hotter climates to allow enough space for air circulation around your refrigerator.

Leveling

The refrigerator must have all bottom corners resting firmly on a solid floor. The floor must be strong enough to support a fully loaded refrigerator. **NOTE:** It is very important for your refrigerator to be level in order to function properly. If the refrigerator is not leveled during installation, the door may be misaligned and not close or seal properly, causing cooling, frost or moisture problems.

How to Level Your Refrigerator

After removing all interior and exterior packaging materials, and discarding crating screws and wood base, use a carpenter's level to level the refrigerator from front-to-back. Adjust the leveling feet in front, a half bubble higher, so that the door closes easily when left halfway open.

ENERGY SAVING TIPS

Cleaning

- Wash any removable parts of the refrigerator interior and exterior with a mild detergent and warm water. Wipe dry. Do not use harsh cleaners on these surfaces.
- Do not use razor blades or other sharp instruments, which can scratch the appliance surface when removing adhesive labels. Any glue left from the tape can be removed with a mixture of warm water and mild detergent, or touch the residue with the sticky side of the tape already removed. Do not remove the serial plate.

CAUTION

To allow the door to close and seal properly, **DO NOT** let food packages extend past the front of shelves.

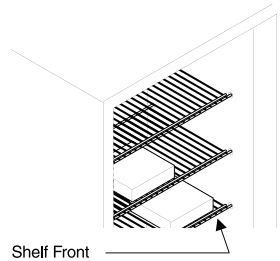

ENERGY SAVING TIPS

- Install the refrigerator in the coolest part of a dry and ventilated room, out of direct sunlight and away from heating ducts or registers. Do not place the refrigerator next to heat-producing appliances such as a range, oven or dishwasher.
- Level the refrigerator so the door closes tightly.
- Do not overcrowd the refrigerator or block cold air vents. Doing so causes the refrigerator to run longer and use more energy. Shelves should not be lined with aluminum foil, wax paper or paper towels. Liners interfere with cold air circulation, making the refrigerator less efficient.
- Wipe bottles and containers dry before placing them in the refrigerator. This cuts down on moisture build-up inside the unit.
- Organize the refrigerator to reduce door openings. Remove as many items as needed at one time, and close the door as soon as possible.

DOOR REVERSAL INSTRUCTIONS

Caution: To avoid injury to yourself and/or property, we recommend someone assist you during the door reversal process.

Ensure the appliance is unplugged and empty. Adjust the two leveling feet to their highest position. We recommend you have someone to assist you.

Tools Required:
Cross-head screw driver

NOTE:

To take the door off, it is necessary to tilt the appliance backward. You should rest the appliance on something solid like a chair just below the top panel so you can access the bottom of the refrigerator.

DO NOT lay the appliance completely flat as this may damage the coolant system.

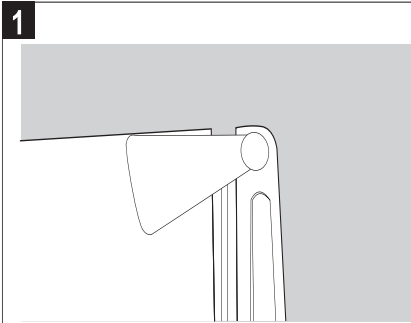

1 Remove the plastic covering from the top door hinge.

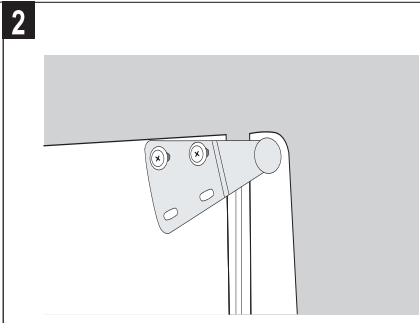

2 Unscrew the two screws from the bottom bracket. Remove the foot from opposite side.

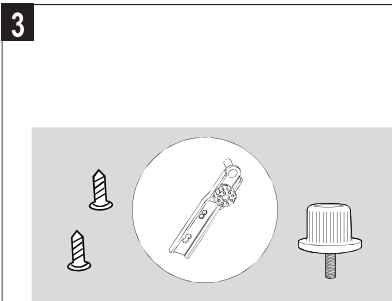

3 Place to one side.

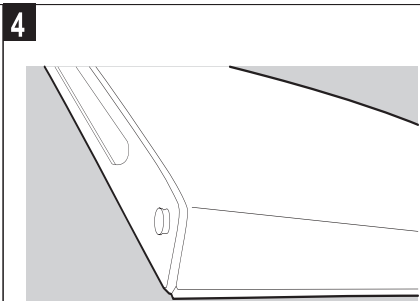

4 Slide the Appliance door down about 15cm and off the Top hinge pin and lift away from the Appliance.

DOOR REVERSAL INSTRUCTIONS

Continued

5

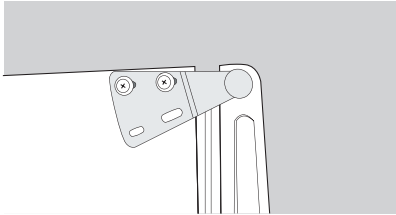

Remove the two screws from top bracket and replace on the otherside. You will need to first remove the plastic caps from the other side.

6

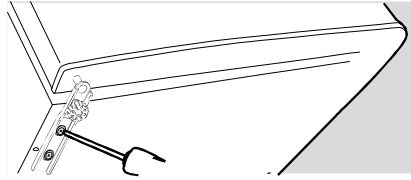

Slide the Appliance door back on to the Top hinge, making sure it is the right way up. Screw the bottom hinge into place on the new side. Replace the other foot on the other side. Replace the plastic covering by clicking back into position on the door hinge.

7

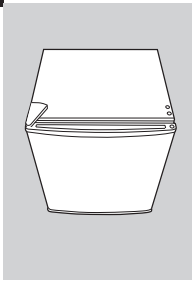

Check that the door is aligned horizontally and vertically and that the seals are closed on all sides before finally tightening the bottom hinge.

Re-adjust the levelling feet.

TEMPERATURE CONTROL

- The temperature selector knob is located on the right-hand interior wall of the refrigerator.
OFF Setting: Unit off
MIN Setting: Less cool temperature
MED Setting: Normal operation (adequate for most situations)
MAX Setting: Coolest temperature
- During high ambient temperatures on hot summer days, it may be necessary to set the thermostat to the coolest setting MAX.
- This may cause the compressor to run continuously in order to maintain a low temperature in order to maintain a low temperature in the cabinet.
- The first time you use your refrigerator, set the thermostat knob to MED.
Give your refrigerator time to cool down completely before adding food. It is recommended to wait 24 hours before adding food.
- When the thermostat control knob is set to OFF, the refrigerator will not run.

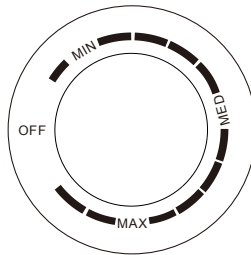

REFRIGERATOR COMPONENTS

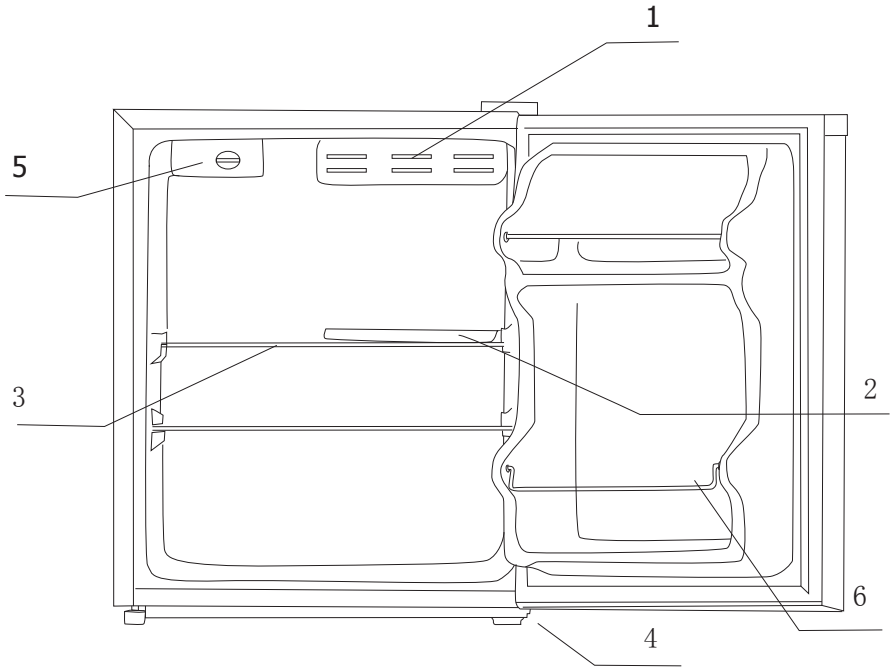

- 1.Small door 2. Drain tray 3. Steel wire shelf
4.Adjustable foot 5.Thermostat 6.Wire steel bar

BEFORE YOU CALL

PROBLEM	CAUSE	CORRECTION
REFRIGERATOR OPERATION		
Refrigerator does not run.	<ul style="list-style-type: none"> Refrigerator is plugged into a circuit that has a ground fault interrupter (GFI). Temperature control is in the OFF position. Refrigerator may not be plugged in, or plug may be loose. A house fuse has blown or a circuit breaker has tripped. Power outage. 	<ul style="list-style-type: none"> Use another circuit. If you are unsure about the outlet, have it checked by a certified technician. See TEMPERATURE CONTROL Section. Ensure the plug is tightly pushed into outlet. Check/replace fuse with a 15 Amp time-delay fuse. Reset the circuit breaker. Check house lights. Call the local electric company.
Refrigerator runs too much or too long.	<ul style="list-style-type: none"> Room or outside weather is hot. Refrigerator has recently been disconnected for a period of time. Large amounts of warm or hot food has been stored recently. The door is opened too frequently or for too long. Refrigerator door may be slightly open. Temperature control is set too low. Refrigerator gasket is dirty, worn, cracked or poorly fitted. 	<ul style="list-style-type: none"> It's normal for the refrigerator to work harder under these conditions. It takes 4 hours for the refrigerator to cool down completely. Warm food will cause refrigerator to run more until the desired temperature is reached. Warm air entering the refrigerator causes it to run more. Open door less often. See DOOR PROBLEMS Section. Turn control knob to a warmer setting. Allow several hours for the temperature to stabilize. Clean or change gasket. Leaks in the door seal will cause refrigerator to run longer in order to maintain desired temperature.
Interior refrigerator temperature is too cold.	<ul style="list-style-type: none"> Temperature control is set too low. 	<ul style="list-style-type: none"> Turn the control to a warmer setting. Allow several hours for the temperature to stabilize.
Interior refrigerator temperature is too warm.	<ul style="list-style-type: none"> Temperature control is set too warm. Door is opened too frequently or for too long. Door may not be closing properly. Large amounts of warm or hot food has been stored recently. Refrigerator has recently been disconnected for a period of time. 	<ul style="list-style-type: none"> Turn the control to a colder setting. Allow several hours for temperature to stabilize. Warm air entering the refrigerator causes it to run more. Open door less often. See the DOOR PROBLEMS Section. Warm food will cause refrigerator to run more until the desired temperature is reached. It takes 4 hours for the refrigerator to cool down completely.
Refrigerator external surface temperature is warm.	<ul style="list-style-type: none"> The external refrigerator walls can be as much as 30°F warmer than room temperature. 	<ul style="list-style-type: none"> This is normal while the compressor works to transfer heat from inside the refrigerator cabinet.
SOUND AND NOISE		
Louder sound levels when refrigerator is on.	<ul style="list-style-type: none"> Modern refrigerators have increased storage capacity and more stable temperatures. They require a high-efficiency compressor. 	<ul style="list-style-type: none"> This is normal. When the surrounding noise level is low, you might hear the compressor running while it cools the interior.

BEFORE YOU CALL (continued)

PROBLEM	CAUSE	CORRECTION
SOUND AND NOISE (continued)		
Longer sound levels when compressor comes on.	<ul style="list-style-type: none"> Refrigerator operates at higher pressures during the start of the ON cycle. 	<ul style="list-style-type: none"> This is normal. Sound will level off or disappear as refrigerator continues to run.
Fan runs when room temperature is below 45°F.	<ul style="list-style-type: none"> Exterior thermostat has activated the heater or fan. 	<ul style="list-style-type: none"> This is normal.
Popping or cracking sound when compressor comes on.	<ul style="list-style-type: none"> Metal parts undergo expansion and contraction, as in hot water pipes. 	<ul style="list-style-type: none"> This is normal. Sound will level off or disappear as refrigerator continues to run.
Boiling or gurgling sound, like water boiling.	<ul style="list-style-type: none"> Refrigerant (used to cool refrigerator) is circulating throughout the system. 	<ul style="list-style-type: none"> This is normal.
Vibrating or rattling noise.	<ul style="list-style-type: none"> Refrigerator is not level. It rocks on the floor when it is moved slightly. 	<ul style="list-style-type: none"> Level the unit. Refer to leveling instructions in the INSTALLATION Section.
Snapping sound.	<ul style="list-style-type: none"> Cold control turning the refrigerator OFF and ON. 	<ul style="list-style-type: none"> This is normal.
WATER/MOISTURE/FROST INSIDE REFRIGERATOR		
Moisture forms on inside of refrigerator walls.	<ul style="list-style-type: none"> Weather is hot and humid. Door may not be seating properly. Door is kept open too long, or opened too frequently. 	<ul style="list-style-type: none"> This is normal. See DOOR PROBLEMS Section. Open the door less often.
WATER/MOISTURE/FROST OUTSIDE REFRIGERATOR		
Moisture forms on outside of refrigerator.	<ul style="list-style-type: none"> Door may not be seating properly, causing the cold air from inside the refrigerator to meet warm moist air from outside. 	<ul style="list-style-type: none"> See DOOR PROBLEMS Section.
ODOR IN REFRIGERATOR		
Odors in refrigerator.	<ul style="list-style-type: none"> Interior needs to be cleaned. 	<ul style="list-style-type: none"> Clean interior with sponge, warm water, and baking soda.
DOOR PROBLEMS		
Door will not close.	<ul style="list-style-type: none"> Refrigerator is not level. It rocks on the floor when it is moved slightly. 	<ul style="list-style-type: none"> This condition may force the cabinet out of square and misalign the door. Refer to "Leveling" in the INSTALLATION Section.

For more information, please visit our website
www.midea.com



make yourself at home

Midea Group All Right Reserved.
CS174I-BP11M

Customer service
Toll free: 1-866-646-4332
www.midea.com