

# Service Manual

## BMF No Frost Series

Applicable Models	Model Code	Applicable Models
HD-332RWEN	CE-BCD255WE-JT	22031020008041

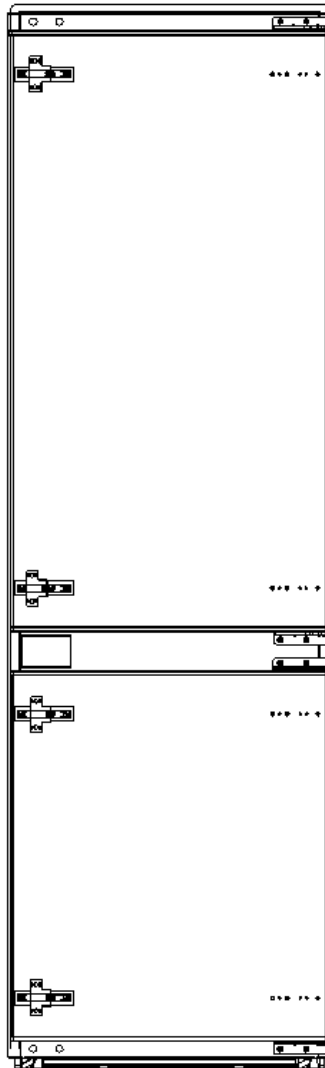

The picture in this service manual is only for reference, and specific appearance and configuration are subject to the real product.

This manual mainly teaches the method, the specific work skill needs engineer to accumulate through the daily work.

 **WARNING**

**Important Safety Notice**

There are special components used in this equipment which are important for safety. These parts are marked by  in the Schematic Diagrams, Circuit Board Diagrams, Exploded Views and Replacement Parts List. It is essential that these critical parts should be replaced with manufacturer's specified parts to prevent shock, fire or other hazards. Do not modify the original design without permission of manufacturer.

 **WARNING**

**Important Safety Notice**

The Maintenance Manual is only for the use of maintenance personnel with certain experience and background in electrical, electronic and mechanical field.

Any attempt to repair main devices may lead to personal injury and property loss.

Manufacturers or distributors are not responsible for the content of the Manual and interpretation thereof.

**Midea Refrigerators**

Technical Maintenance Manual

Copyright @2017

All rights reserved. Replication of all or part of the Manual in any forms shall not be allowed without written approval by the Overseas Sales Corporation of Midea Refrigerators.

# Contents

<b>1. SIGNIFICANT UPDATE NOTES (NONE)</b> .....	<b>5</b>
<b>2. SAFETY WARNING CODE</b> .....	<b>6</b>
2.1 WARNING FOR OPERATION SAFETY .....	6
2.2 SAFETY INSTRUCTION FOR REFRIGERANT .....	8
<b>3. INSTALLATION AND COMMISSIONING</b> .....	<b>9</b>
3.1 HANDLING.....	9
3.2 DOOR DISASSEMBLY AND ASSEMBLY .....	9
3.3 INSTALLATION LOCATION .....	9
3.4 LEVELING OF THE REFRIGERATOR .....	12
3.5 LEFT OR RIGHT OPEN DOOR REVERSAL .....	13
<b>4. MAIN PARTS AND EXTERNAL DIMENSION</b> .....	<b>16</b>
4.1 MAIN PARTS.....	16
4.2 EXTERNAL DIMENSION.....	17
4.3 MIDEA PRODUCT SERIAL NUMBER AND LOCATION .....	17
<b>5. ELECTRIC CONTROL SYSTEM</b> .....	<b>19</b>
5.1 ELECTRICAL PARAMETERS .....	19
5.2 CIRCUIT DIAGRAM .....	20
5.3 MAIN CONTROL BOARD STRUCTURE DIAGRAM .....	21
<b>6. REFRIGERATION SYSTEM</b> .....	<b>22</b>
6.1 REFRIGERATING PIPING SYSTEM.....	22
6.2 COOLING PIPELINE AND DRAIN PIPE INSIDE THE CABINET.....	22
6.3 CIRCULATING ROUTE OF COOLING AIR .....	23
6.4 WELDING POINTS IN CHAMBERS OR FOAM LAYER.....	23
6.5 WELDING POINT IN THE COMPRESSOR CASE .....	24
<b>7. DISMANTLING OF PARTS</b> .....	<b>25</b>
7.1 PARTS ON THE DOOR.....	25
7.2 PARTS INSIDE THE REFRIGERATOR .....	25
7.3 LIGHT SYSTEM.....	26
7.4 AIR DUCT COMPONENTS REFRIGERATING CHAMBER AND FAN MOTOR.....	27
7.5 AIR DUCT COMPONENTS IN FREEZING CHAMBER AND FAN MOTOR.....	28
7.6 EVAPORATOR AND DEFROST SYSTEM.....	28
7.7 COMPRESSOR CASE.....	29
7.8 DISPLAY CONTROL BOARD .....	34
7.9 MAIN CONTROL BOARD .....	35
<b>8. TEMPERATURE SENSING SYSTEM</b> .....	<b>36</b>
8.1 POSITION OF SENSORS .....	36

---

---

8.2 REPLACEMENT OF SENSORS .....	36
8.3 SENSOR WITHOUT TERMINAL REPLACEMENT.....	37
8.4 SENSOR RESISTANCE (R/T).....	38
<b>9. FUNCTION AND OPERATION .....</b>	<b>40</b>
9.1 DISPLAY OPERATION PANEL .....	40
9.2 DISPLAY .....	40
9.3 SETTING OF THE GEAR.....	40
9.4 LOCK AND UNLOCK SETTINGS.....	41
9.5 MEMORY FUNCTION.....	41
9.6 CONTROL OF STANDBY FUNCTION .....	41
9.7 OPEN DOOR ALARM (NONE).....	41
9.8 FUNCTION SELECTION (NONE).....	41
9.9 FAULT CODE AND SOLUTIONS.....	41
9.10 DEFROSTING FUNCTION.....	42
9.11 TEST MODE.....	42
<b>10. COMPRESSOR .....</b>	<b>44</b>
10.1 COMPRESSOR ON AND OFF CONTROL SPECIFICATIONS.....	44
<b>11. TROUBLESHOOTING METHOD .....</b>	<b>45</b>
11.1 NO COOLING (AIR COOLING-ELECTRONIC).....	45
11.2 NO WORKING OF COMPRESSOR.....	46
11.3 INSIDE FROSTING, NO DEFROSTING .....	46
11.4 INSIDE FROSTING, NO DEFROSTING-MAINTENANCE GUIDELINES .....	47
11.5 LIGHT IS NOT ON.....	48
11.6 FAN FAILURE .....	48
11.7 DEFECTIVE DEFROST CIRCUIT .....	49
11.8 NOISE .....	49
11.9 AIR DUCT NOT OPERATED (ELECTRONICALLY) (NONE).....	50
<b>12. FIGURES AND DETAILS OF REPAIR PARTS.....</b>	<b>51</b>

---

---

**1. Significant update notes (None)**

---

---





---

## 2. Safety Warning Code

---

### 2.1 Warning for operation safety

#### Important Safety Instructions

	<b>CAUTION RISK OF ELECTRIC SHOCK DO NOT OPEN</b>	
	This symbol indicates that dangerous voltage constituting a risk of electric shock is present within your freezer.	
	This symbol indicates that there are important operating and maintenance instructions in the literature accompanying your freezer.	

#### WARNING

- 1) Read these instructions.
- 2) Keep these instructions.
- 3) Heed all warnings.
- 4) Follow all instructions.
- 5) Do not use this appliance near water.
- 6) Clean only with a damp cloth.
- 7) Do not block any ventilation openings.
- 8) Install in accordance with the manufacturer's instructions.
- 9) Do not install near any heat sources, such as radiators, heat registers, stoves, or other apparatus that produce heat.
- 10) Do not defeat the safety purpose of the polarized or grounding-type plug. A polarized plug has two blades with one wider than the other. A grounding type plug has two blades and a third grounding prong. The wide blade or the third prong are provided for your safety. If the provided plug does not fit into your outlet, consult an electrician for replacement of the obsolete outlet.
- 11) Protect the power cord from being walked on or pinched, particularly at plugs, convenience receptacles, and the point where they exit from the appliance.
- 12) Do not attempt to modify or extend the power cord of this appliance.
- 13) Unplug this appliance during lightning storms or when it will not be used for long periods of time.
- 14) Make sure that the available AC power matches the voltage requirements of this appliance.

## CONNECTING ELECTRICITY

**WARNING****Electrical Shock Hazard.**

Plug into a grounded 3-prong outlet.  
Do not remove the ground prong.  
Do not use an adapter.

Failure to follow these instructions can result in death, fire, or electrical shock.

**WARNING****Electric Shock Hazard**

**Failure to follow these instructions can result in electric shock, fire, or death.**

- 1) **WARNING**—Keep ventilation openings, in both the freezer and the built-in structure, clear of obstruction.
- 2) **WARNING**—Do not touch the interior of the freezer with wet hands. This could result in frost bite.
- 3) **WARNING**—Do not use mechanical devices or other means to accelerate the defrosting process, other than those recommended by the manufacturer.
- 4) **WARNING**—Do not damage the refrigerant circuit.
- 5) **WARNING**—Do not damage the refrigerant tubing when handling, moving, or using the freezer.
- 6) **WARNING—DANGER**—Never allow children to play with, operate, or crawl inside the freezer. Risk of child entrapment. Before you throw away your old freezer:
  - 6-1) Take off the doors
  - 6-2) Leave the shelves in place so that children may not easily climb inside
- 7) Unplug the freezer before carrying out user maintenance on it.
- 8) This freezer can be used by children age eight years and older and persons with reduced physical or mental capabilities or lack of experience and knowledge if they are given supervision or instruction concerning the use of the freezer in a safe way and understand the hazards involved. Children should not play with the freezer. Cleaning and maintenance should not be performed by children without supervision.
- 9) If a component part is damaged, it must be replaced by the manufacturer, its service agent, or similar qualified persons in order to avoid a hazard.
- 10) Please dispose of the freezer according to local regulations as the freezer contains flammable gas and refrigerant.
- 11) Follow local regulations regarding disposal of the freezer due to flammable refrigerant and gas. All refrigeration products contain refrigerants, which under the guidelines of federal law must be removed before disposal. It is the consumer's responsibility to comply with federal and local regulations when disposing of this product.
- 12) This freezer is intended to be used in household and similar environments.

13) Do not store or use gasoline or any flammable liquids inside or in the vicinity of this freezer.

14) Do not use extension cords or ungrounded (two-prong) adapters with this freezer. If the power cord is too short, have a qualified electrician install an outlet near the freezer. Use of an extension cord can negatively affect the freezer's performance.

### Grounding requirement

This freezer must be grounded. This freezer is equipped with a cord having a grounding wire with a grounding plug. The plug must be inserted into an outlet that is properly installed and grounded.

Improper use of the grounding plug can result in a risk of electric shock. Consult a qualified electrician or service person if the grounding instructions are not completely understood, or if doubt exists as to whether the freezer is properly grounded.

### 2.2 Safety instruction for refrigerant

 **WARNING**



**Explosion Hazard.**

Keep flammable materials and vapors, such as gasoline, away from freezer. Failure to do so can result in fire, explosion, or death.



### **Safety instruction for refrigerant**

DANGER—Risk of Fire or Explosion. Flammable Refrigerant Used. To Be Repaired Only By Trained Service Personnel. Do Not Use Mechanical Devices. Do Not Puncture Refrigerant Tubing. CAUTION—Risk of Fire or Explosion. Flammable Refrigerant Used. Consult Repair Manual/Owner's Guide Before Attempting To Service This Product. All Safety Precautions Must be Followed. CAUTION—Risk of Fire or Explosion. Dispose of Properly In Accordance With Federal Or Local Regulations. Flammable Refrigerant Used. CAUTION—Risk of Fire or Explosion Due To Puncture Of Refrigerant Tubing; Follow Handling Instructions Carefully. Flammable Refrigerant Used.

### 3. Installation and commissioning

#### 3.1 Handling

##### Handling

- 1) Protect the refrigerator in moving it, Same as shown as left photo, please move it by handcart with cushion
- 2) Remove all packing materials and bottom cushion, then move into house for placement
- 3) After moving it to appropriate location, wait for 2 hours before power on.

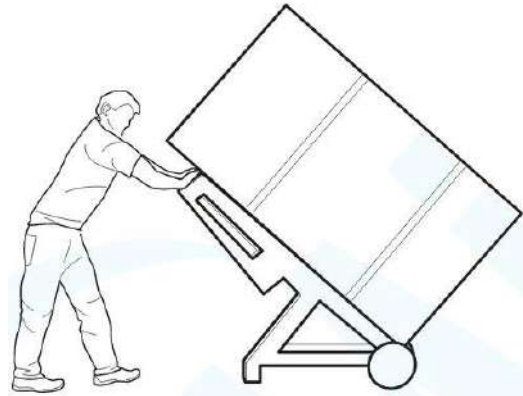

#### 3.2 Door Disassembly and Assembly

The refrigerator door needs to be dismantled if it cannot enter the room in the whole.

#### 3.3 Installation location

##### Installation location

Refrigerator installed in the cabinet and the size requirements such as the right figure.

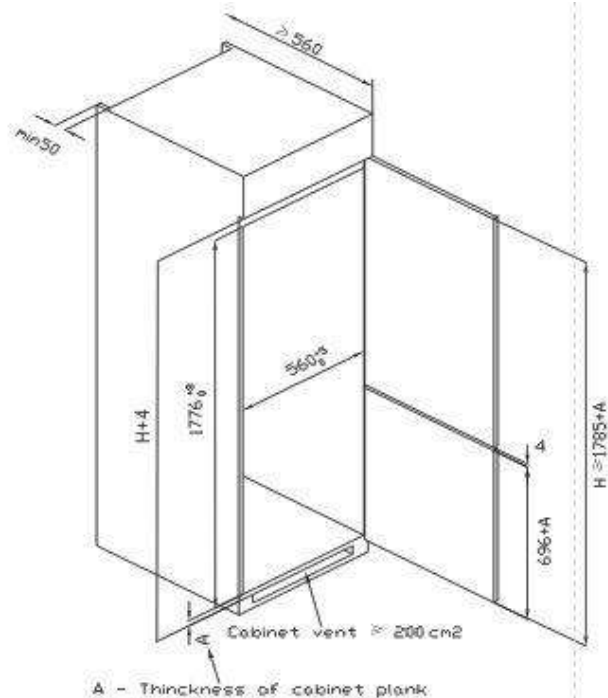

##### Installation Steps

Push the refrigerator into the cabinet and adjusted it to make the baffle flange touch the edge of the cabinet, and the supporting limit is hooked to the bottom edge of the cabinet.

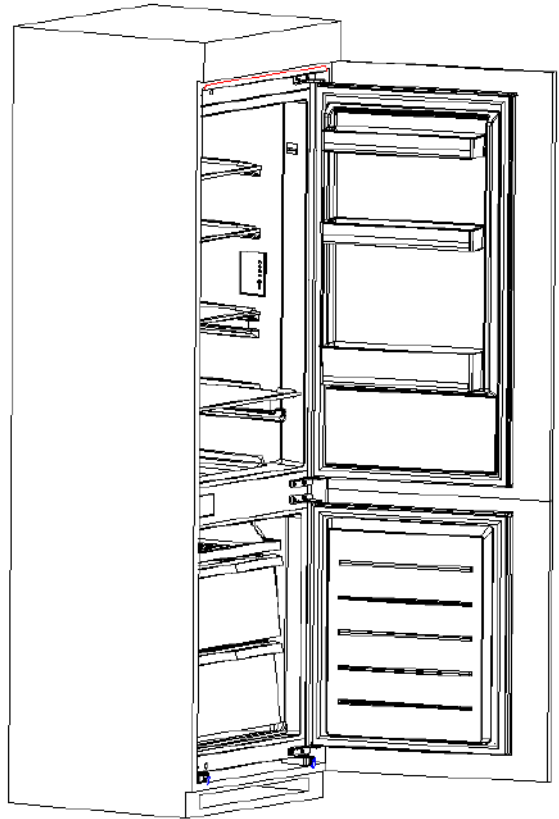

Fix the lower support with screws, and cover the screw cap.

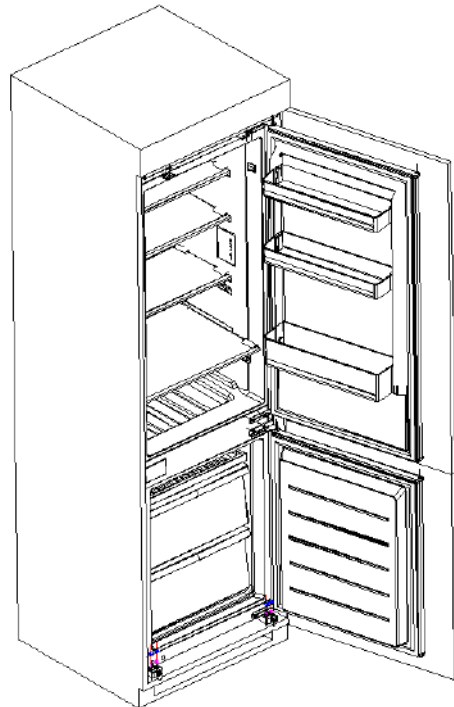

Fix the top baffle to the top of the cabinet with screws, and cover the screw cap.

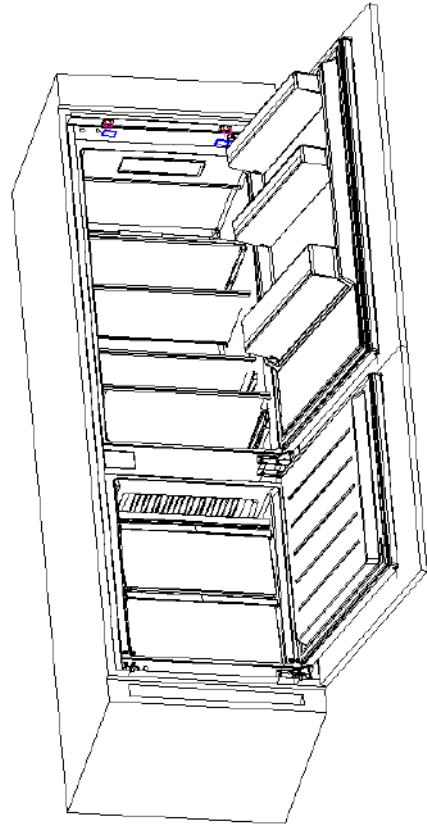

The lower door of the cabinet is opened to the maximum angle, and the lower door of the refrigerator is opened to the corresponding position. Sliding the block to make inner edge align with the door edge, then fix the block to the door with screw and cover the screw cap. Fix the top door to the cabinet door in the same way.

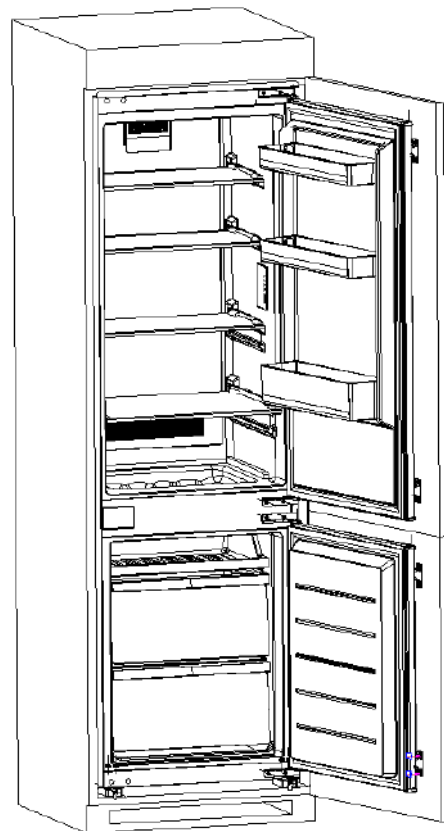

The sealing strip in the accessory is sealed in the gap between the cabinet and the refrigerator.  
Installation is complete.

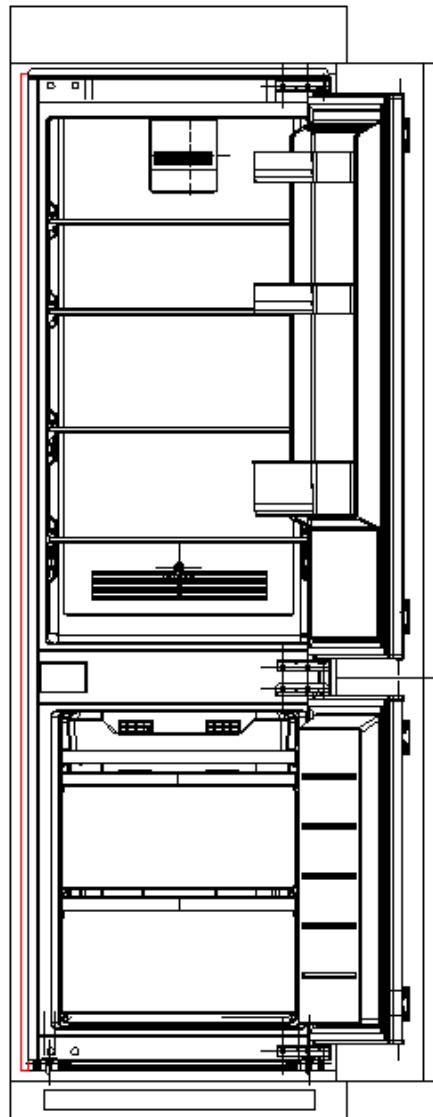

### **3.4 Leveling of the refrigerator**

#### **Leveling of the refrigerator**

If the refrigerator cannot be placed steadily, adjust the footing to level it.

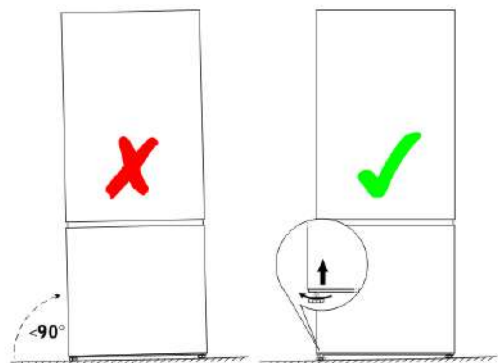

**3.5 Left or right open door reversal**

1. Power off the refrigerator, and remove all objects from the door trays.
2. Remove the upper hinge and hole caps of refrigerator door.

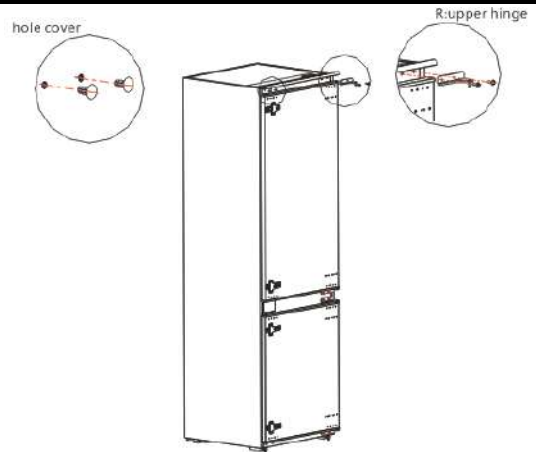

3. Remove the refrigerator door, the bottom hinge and the hole cover.

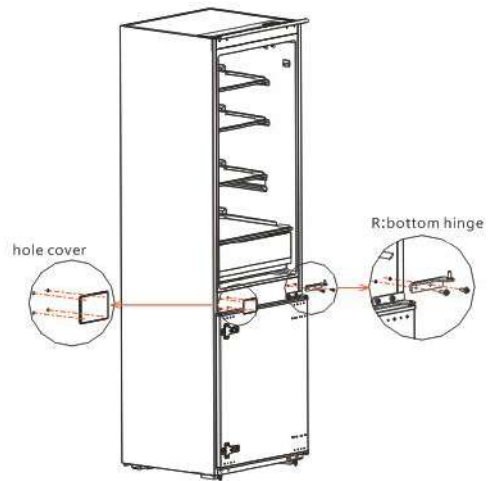

4. Exchange the R:bottom hinge and R:upper hinge, then assemble them and assemble top hole caps.

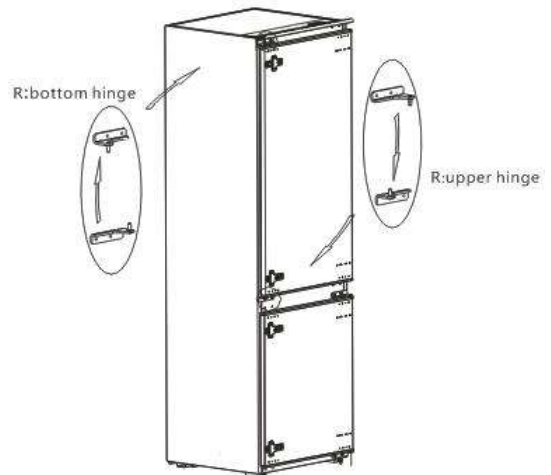

5. Remove the fixed block of refrigerator door and rotate it for 180°, assemble it on other side of refrigerator door.

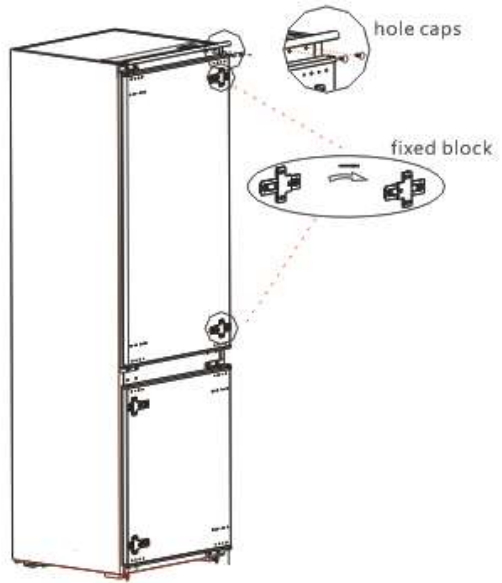

6. Remove the upper hinge of refrigerator door.

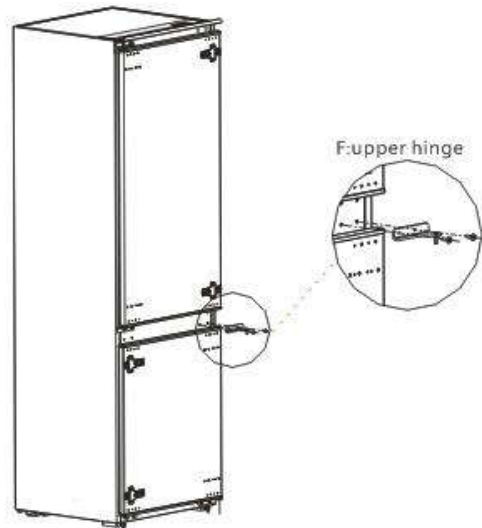

7. Remove the freezer door, the bottom hinge and the hole caps.

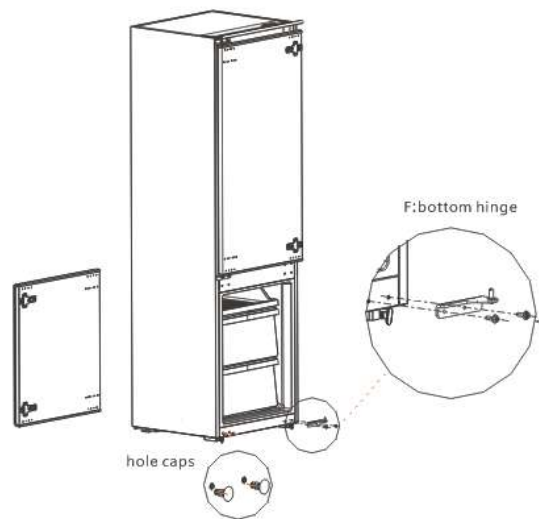

8. Exchange the F:bottom hinge and F:upper hinge ,then assemble them.

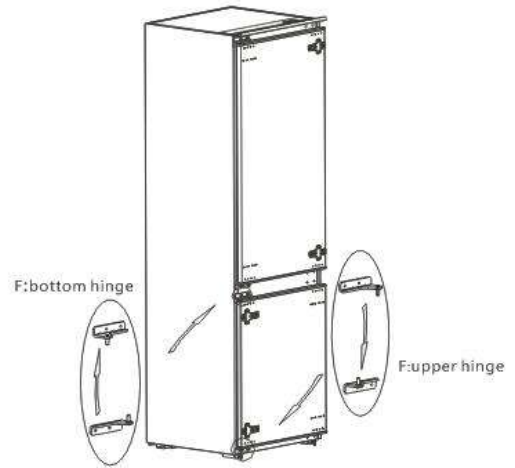

9. Remove the fixed block of refrigerator door and rotate it for 180°, assemble it on other side of refrigerator door.

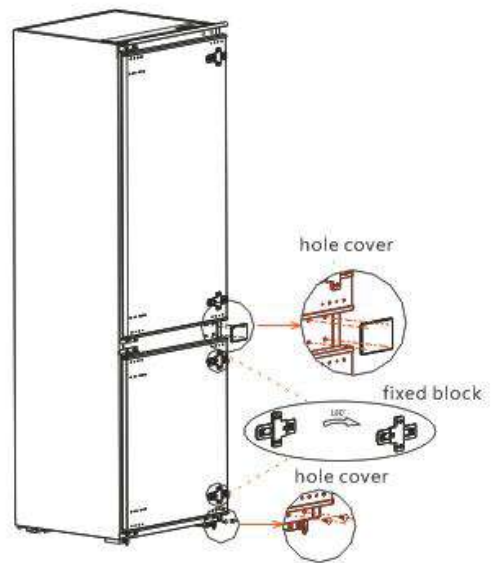

10.Finished

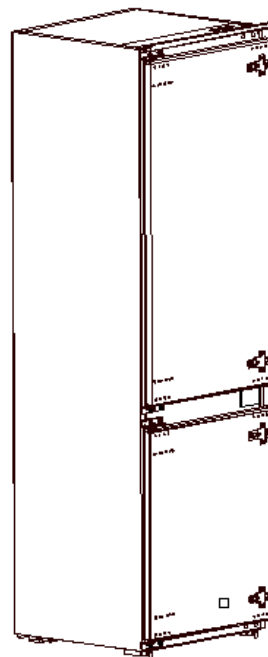

## 4. Main parts and external dimension

### 4.1 Main parts

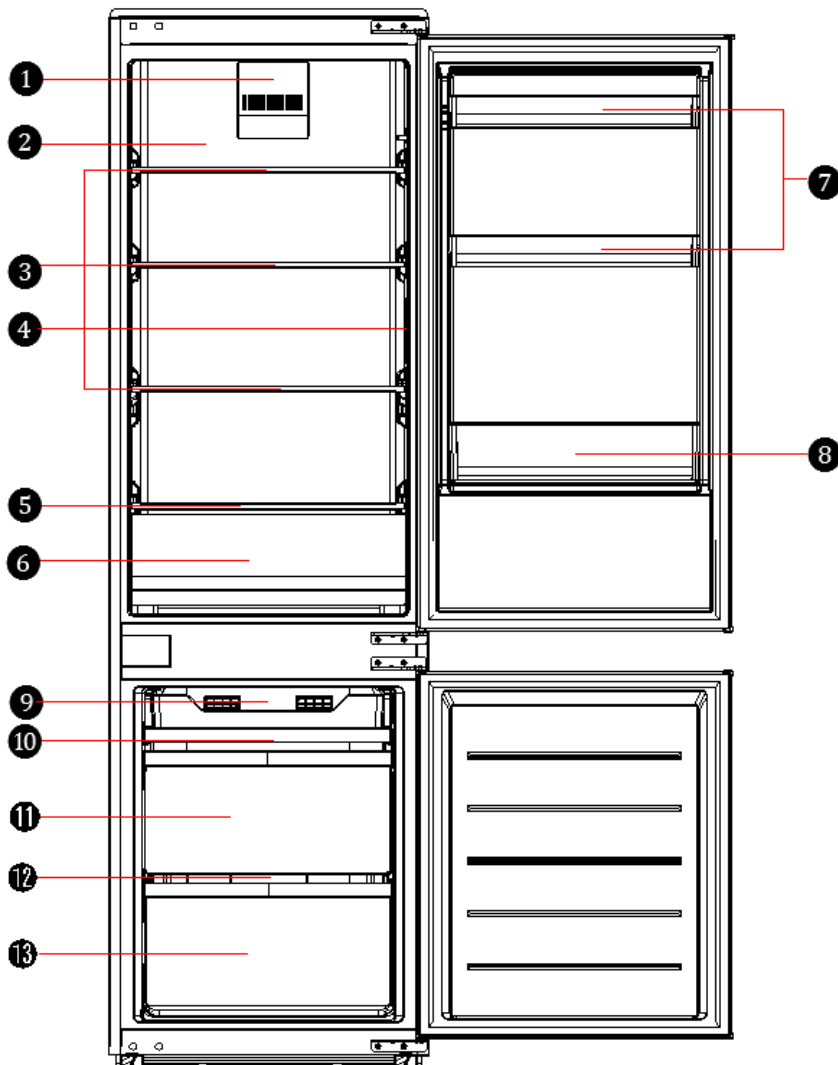

(The picture is only for reference, and specific appearance and configuration are subject to the real product)

Refrigerator chamber	Freezer chamber
<ul style="list-style-type: none"> <li>① R wind channel</li> <li>② R air flue</li> <li>③ glass shelf</li> <li>④ Display control box</li> <li>⑤ glass shelf</li> <li>⑥ Crisper for fruit and vegetable</li> <li>⑦ R small tray</li> <li>⑧ R large tray</li> </ul>	<ul style="list-style-type: none"> <li>⑨ F wind channel</li> <li>⑩ Pizza box</li> <li>⑪ F middle drawer</li> <li>⑫ F air flue</li> <li>⑬ F below drawer</li> </ul>

### 4.2 External dimension

Description	Code	Size (mm)
Height to Top of Case	A	1785
Width	B	540
Depth w/o Handles	C	545
Depth (90 deg. with Door Open)	D	1060
Height to match the cabinet	E	1775
Depth to match the cabinet	F	510

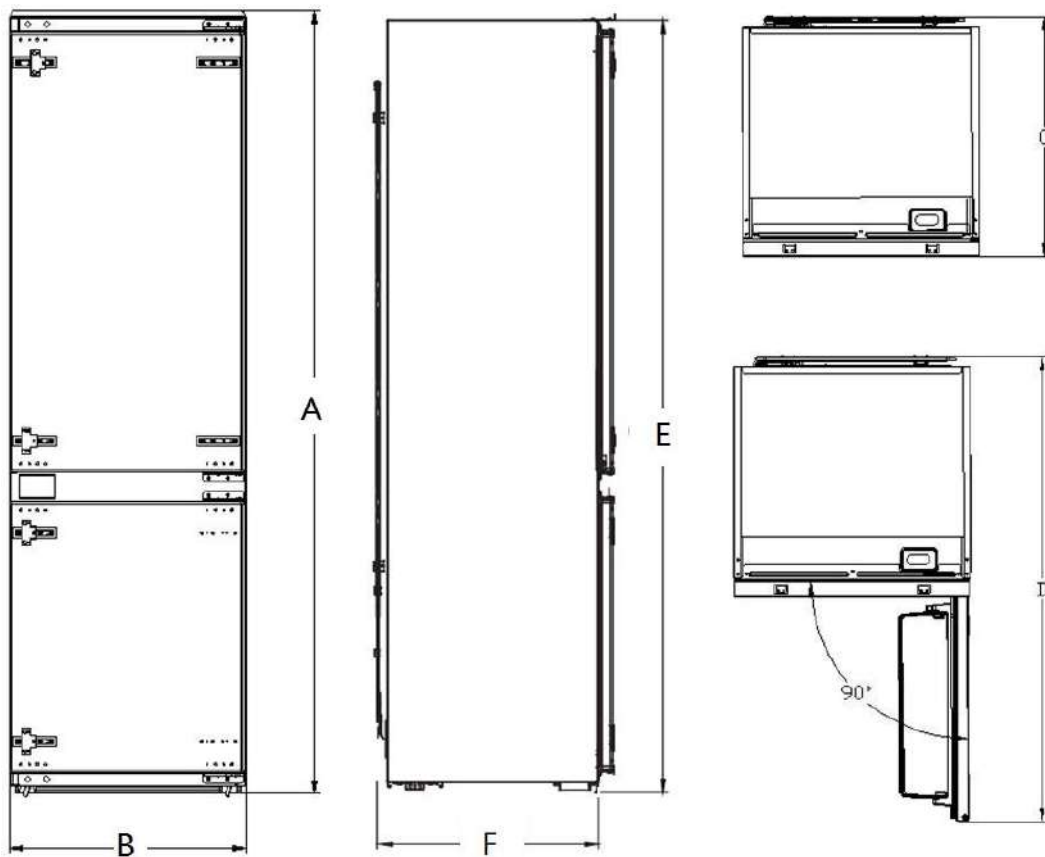

(The picture is only for reference)

### 4.3 Midea product serial number and location

1) **Product Serial Number** — Including order number, production date and other information. When the product occur problem, it needs to be recorded or photographed and provided to us.



2) Paste location

Carton Box

Product

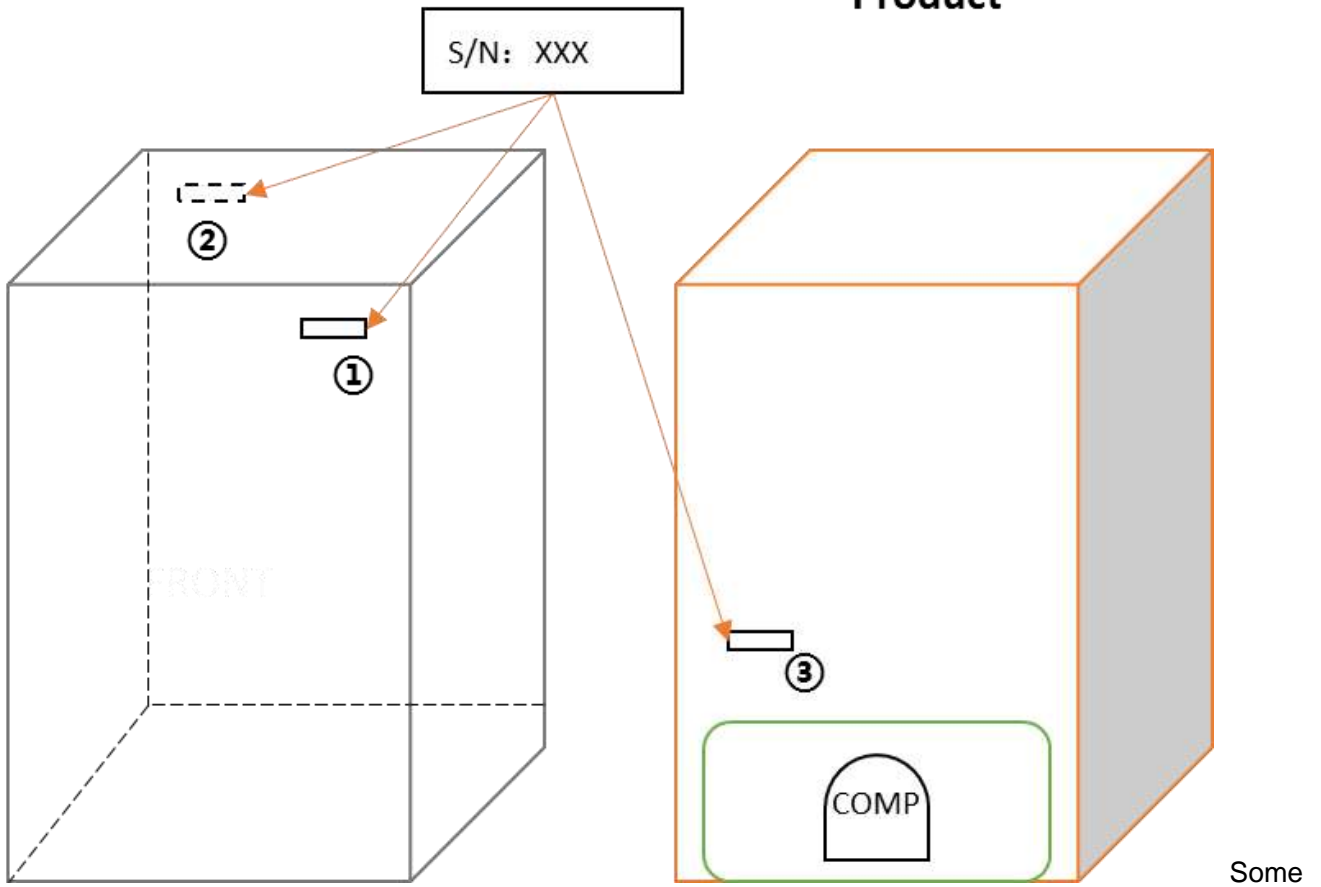

products also have S/N on the lower part of the right side of the Cabinet.

## 5. Electric control system

### 5.1 Electrical parameters

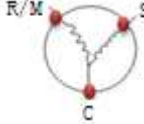
<b>Applicable Models</b>	HD-332RWEN
<b>Product Name</b>	CE-BCD255WE-JT
<b>Product Code</b>	22031020008041
<b>Item</b>	<b>Specification</b>
<b>Compressor</b>	PZ75H1X
<b>Starter(PTC)</b>	TY-QZ-003 QPE2-A15MD3
<b>Overload protector(OLP)</b>	4TM117NFBYY DRB12N61A1
<b>Winding resistance of compressor wiring terminal</b>	Rmc:29.6±7%Ω Rsc:31.5±7%Ω Rms=Rmc+Rsc
<b>Winding resistance picture</b>	
<b>Variable frequency driver board</b>	None
<b>Motor</b>	
<b>Fan motor of the freezing chamber</b>	DC12V/1.8W
<b>Fan motor of the refrigerating chamber</b>	DC12V/1.44W
<b>Ventilation door of the refrigerating chamber</b>	None
<b>Condensation fan</b>	None
<b>separation the ice motor</b>	None
<b>ice output motor</b>	None
<b>Open door motor</b>	None
<b>Lights inside the refrigerator</b>	
<b>Lights inside the freezing chamber</b>	None
<b>Lights inside the refrigerating chamber</b>	12V/2W
<b>Switch of the refrigerator door</b>	Sector

**5.2 Circuit diagram**

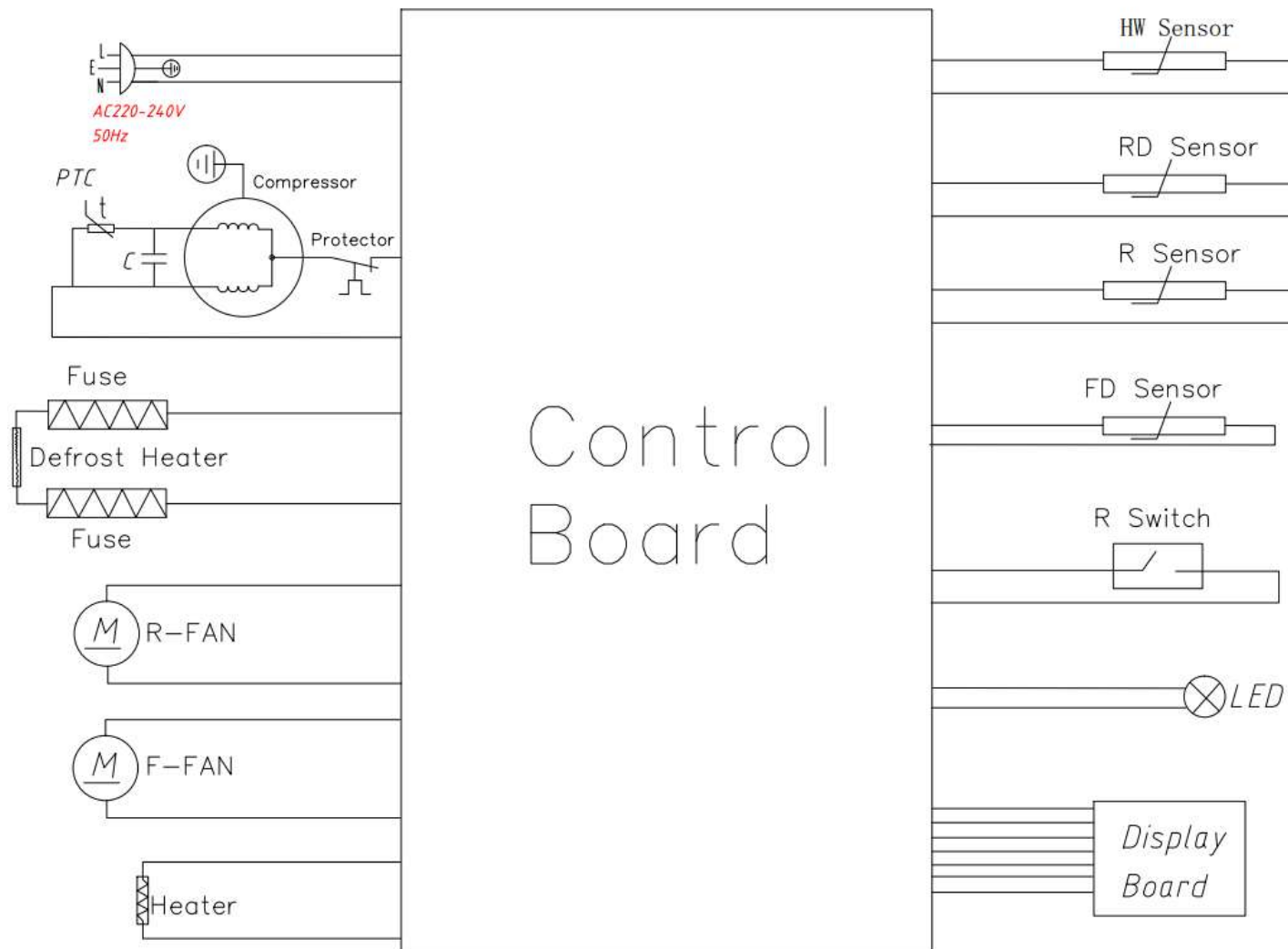

**F: Freezer    R: Refrigerator    RD: Refrigerator defrost    FD: Freezer defrost    HW: Ambient temperature**

**5.3 Main control board structure diagram**

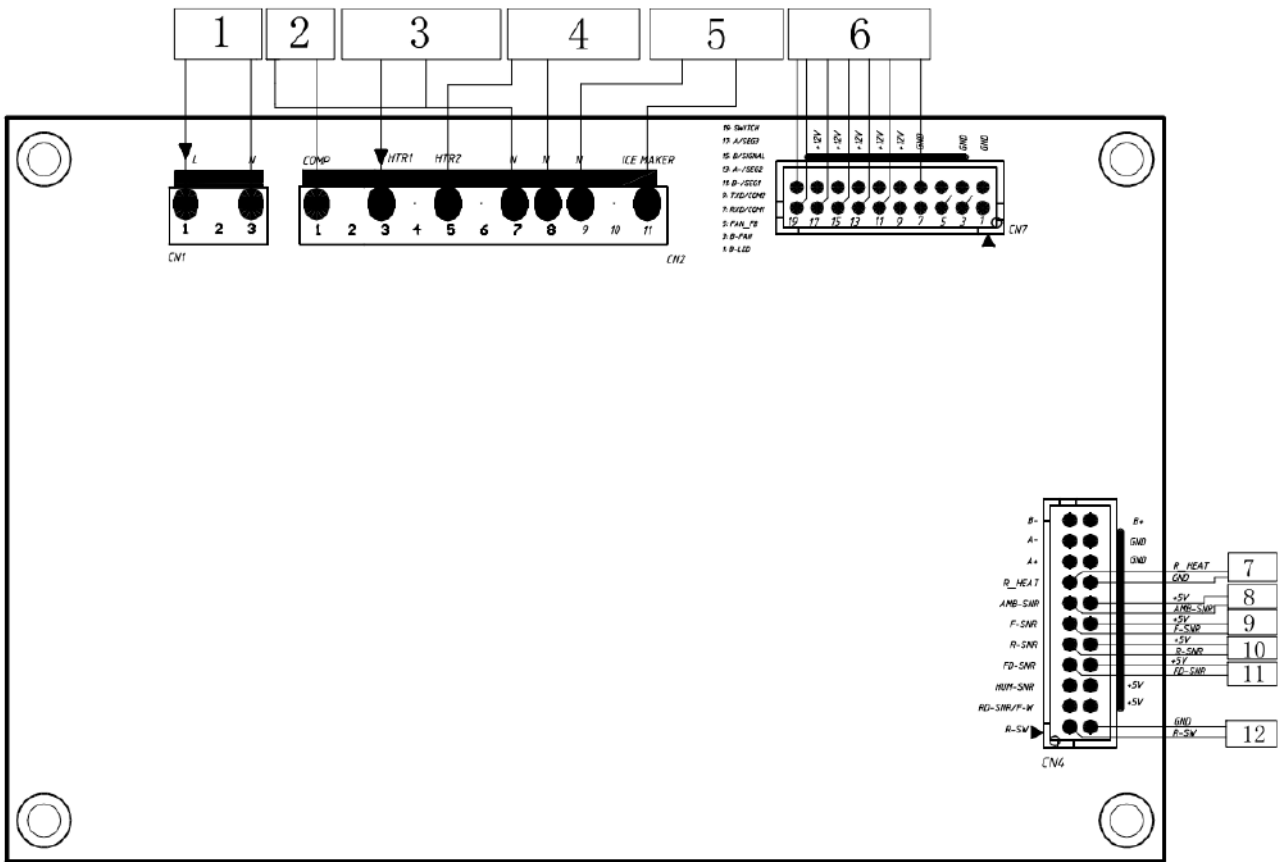

Connecting terminals	Connecting terminals
1. Power supply	8. Ambient temperature sensor
2. Compressor	9. Refrigerator defrost sensor
3. Compensation heater	10. Refrigeration temperature sensor
4. Freezing defrost heater	11. Freezing defrost sensor
5. Fan of freezing chamber	12. Refrigeration light switch
6. Display control panel	
7. LED of refrigeration chamber	

## 6. Refrigeration system

### 6.1 Refrigerating piping system

① Compressor → ② condenser → ③ Anti-condensation tube → ④ Dry filter → ⑤ Capillary tube → ⑥ Evaporator → ⑦ Suction tube → ① Compressor

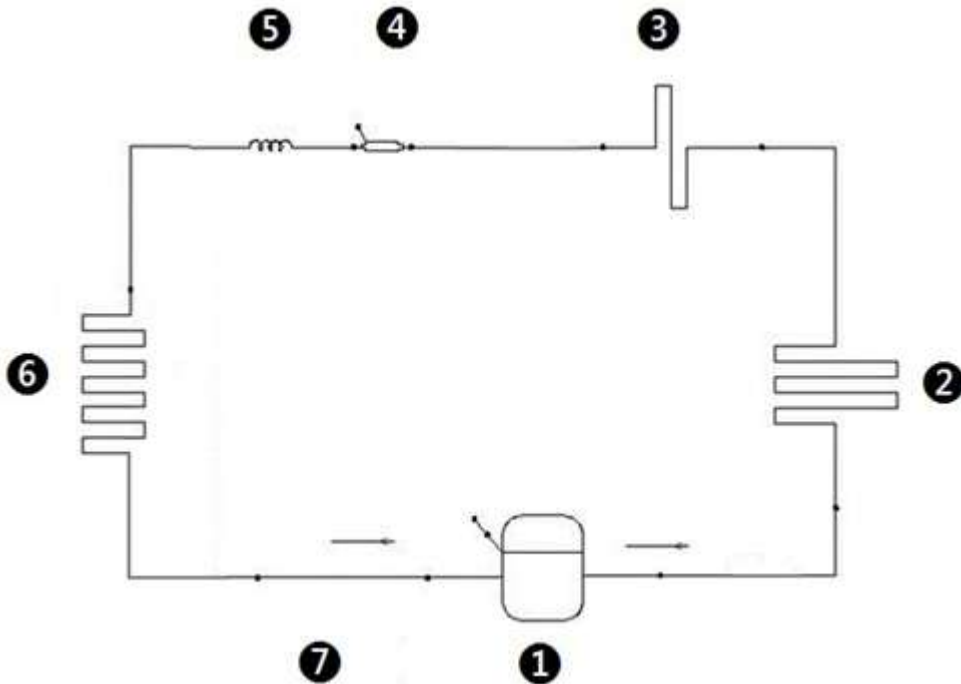

### 6.2 Cooling pipeline and drain pipe inside the cabinet



**6.3 Circulating route of cooling air**

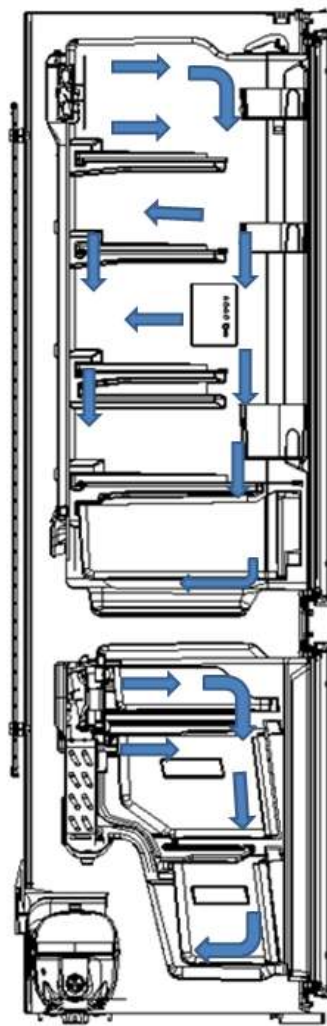

**6.4 Welding points in chambers or foam layer**

1) Welding points on freezer evaporator

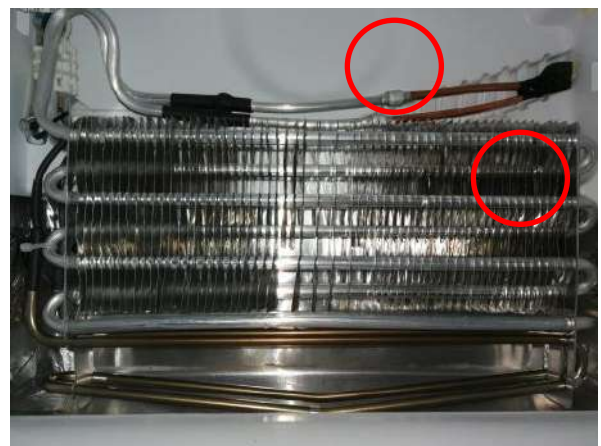

**Welding point**

**Pipe outer diameter (mm)**

1-Freezer capillary and inlet of evaporator

Copper pipe:  $\Phi 6$

Aluminum pipe:  $\Phi 6.35$

2-Heat transition tube and outlet of evaporator

Copper pipe:  $\Phi 6$

Aluminum pipe:  $\Phi 6.35$

**6.5 Welding point in the compressor case**

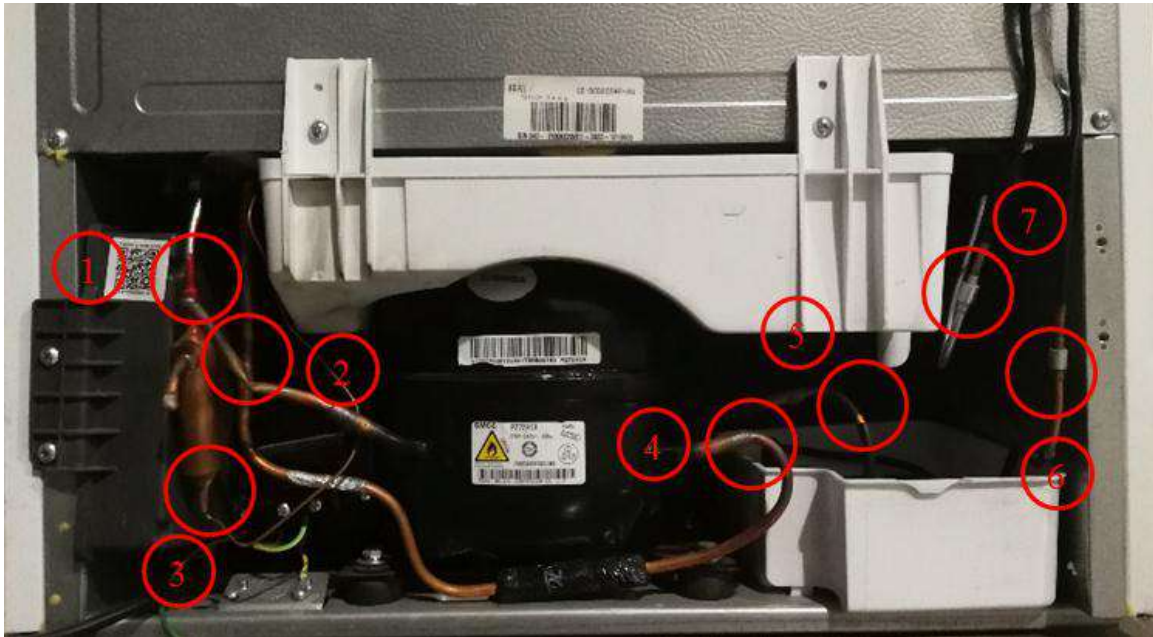

Welding point	Pipe outer diameter (mm)	
1-Outlet of anti-condensation tube and inlet of dry filter	Steel pipe: $\Phi 4.0$	Copper pipe: $\Phi 5.0$
2-Heat transition tube and Suction connection tube	Copper pipe: $\Phi 6.0$	Copper pipe: $\Phi 6.0$
3-Outlet of dry filter and inlet of freezer capillary	Copper pipe: $\Phi 2.8$	Copper pipe: $\Phi 1.8$
4-Suction connection pipe and compressor intake tube	Copper pipe: $\Phi 6.0$	Copper pipe: $\Phi 8.17$
5-Compressor outlet tube and inlet of venting connection tube	Copper pipe: $\Phi 6.17$	Steel pipe: $\Phi 4.0$
6-Outlet of venting connection tube and inlet of <i>condenser</i>	Copper pipe: $\Phi 4.0$	Steel pipe: $\Phi 4.0$
7-Outlet of condenser and inlet of anti-condensation tube	Steel pipe: $\Phi 4.0$	Steel pipe: $\Phi 4.0$

## 7. Dismantling of parts

### 7.1 Parts on the door

#### Door seal

Door seal is installed into door liner groove.

- 1) Open the refrigerator door.
- 2) Take the door seal ① out of door liner.

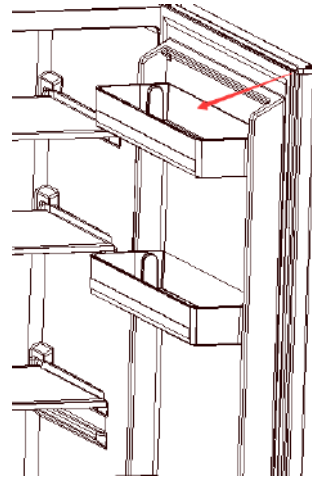

#### Door tray

While squeezing it inward, lift up the baffle and take it out from refrigerator liner.

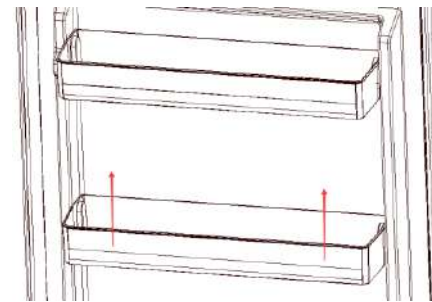

### 7.2 Parts inside the refrigerator

#### Refrigerator Fruit box cover

Remove the crisper cover of ref. compartement according to below steps:

- 1) Take out the crisper firstly.
- 2) Pull out the crisper cover completely.

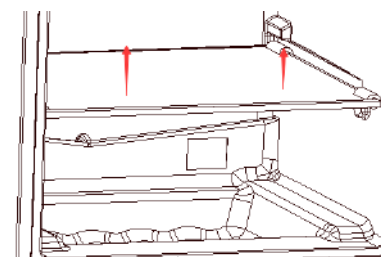
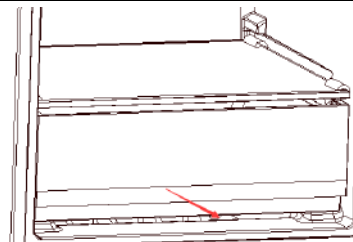

**Shelves**

1) Lift up the division plate with a proper force and pull it out towards yourself.

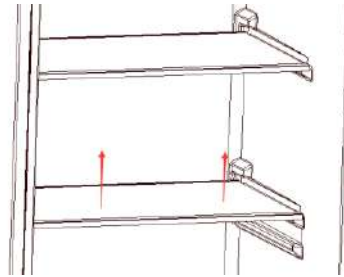

**Drawer**

The drawer is located at the bottom of freezing chambers;

- 1) Pull the drawer out completely
- 2) Lift it up slightly and take it out from the refrigerator.

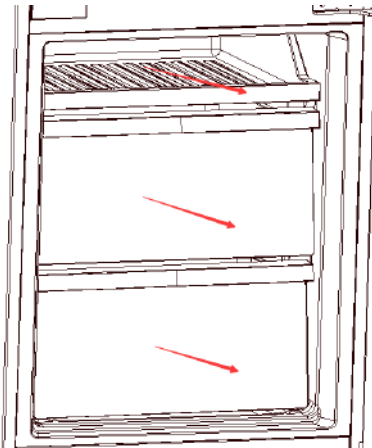

**7.3 Light system**

**Light**

Light of the refrigerating chamber is located upper chamber

- 1) Remove the lamp cover
- 2) Remove the LED lamp
- 3) Remove the LED lamp terminal
- 4) The reverse process can complete installation.





**Light switch**

There is a light switch on the side wall of the refrigerating chamber.

- 1) Loosen the hook with small normal screwdriver and pull out the switch until the wire connector reveals.

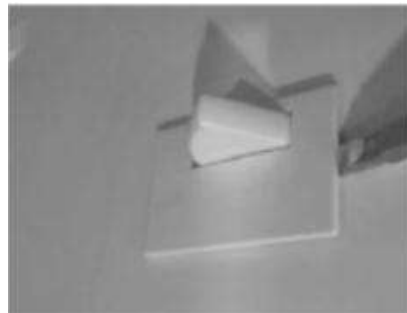

**7.4 Air duct components refrigerating chamber and fan motor**

**Air duct components in freezing chamber**

All accessories in the freezing chamber should be dismantled before removing the air duct components.

- 1) Remove 1 screws on the cover plate of the **refrigerating** air duct using a cross screwdriver.
- 2) Pull out the connector terminal of the fan motor.



**Fan motor of air duct**

- 1) The fan is fastened with clasps and can be removed directly
- 2) Change the fan, the reverse operation for assembly



**Electric damper**

None

## 7.5 Air duct components in freezing chamber and fan motor

### Air duct components in freezing chamber

All accessories in the freezing chamber should be dismantled before removing the air duct components.

- 1) Remove 1 screws on the cover plate of the freezing air duct using a cross screwdriver.
- 2) Pull out the connector terminal of the fan motor.



### Fan

The fan is fastened with clasps and can be removed directly; Change the fan, the reverse operation for assembly



### Damper assembly



None

## 7.6 Evaporator and Defrost system

### Evaporator in freezing chamber

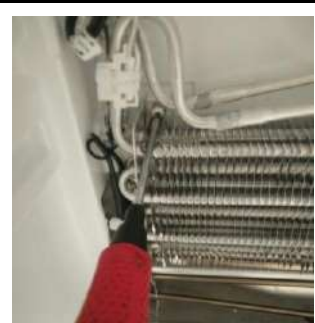
- 1) Remove the air duct components in freezing chamber.
- 2) Disconnect all connectors.
- 3) Remove the welding on inlet and outlet tubes.
- 4) Remove one screws which are used to fix the evaporator and remove the evaporator.



Components on the evaporator	
Defrost thermostat	None
<p><b>Fuse</b></p> <p>The fuse is located on top of the evaporator</p> <ol style="list-style-type: none"> <li>1) connect the fuse connector.</li> <li>2) Cut off the band which fixes the fuse.</li> <li>3) Separate the fuse and the evaporator.</li> </ol> <p>*Don't break the welding of the evaporator in case that only the fuse needs to be replaced.</p>	
<p><b>Defrost heater</b></p> <p>The defrost heater is located at bottom of the evaporator.</p> <ol style="list-style-type: none"> <li>1) Disconnect the connector of defrost heater.</li> <li>2) Cut off the band which fixes the defrost heater.</li> <li>3) Take off the defrost heater from the evaporator.</li> </ol>	

## 7.7 Compressor case

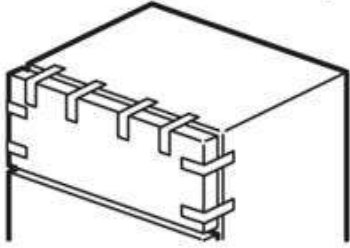
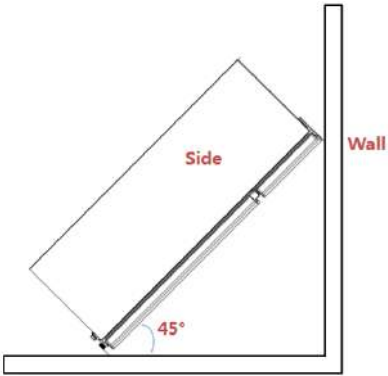
Rear cover and compressor case	
	None
Compressor and the cooling system pipe	
<p>1) Cut off the power, remove the goods in the refrigerator, with the tape to make the door fixed firmly and prevent the door dropping when the refrigerator dumping.</p>	
<p>2) Slowly tilt the refrigerator forward, relying on the wall or a solid enough object, leaving space to facilitate the operation. For safety, it should be carried by someone to prevent its falling.</p>	

3) Cut off the compressor pipeline.-**①**Cut off the process pipeline.-**②**Cut off the low-pressure muffler.-**③**Cut off the high-pressure exhaust pipe.

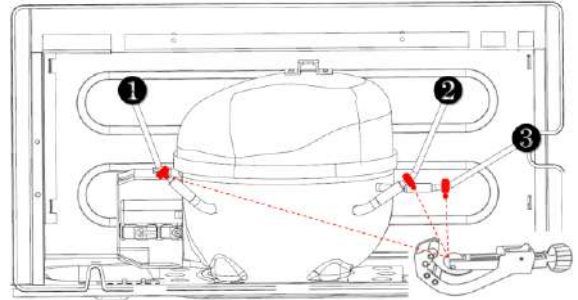

4-1) **Remove the screws(for some models)**

- Two screws outside
- One screw inside

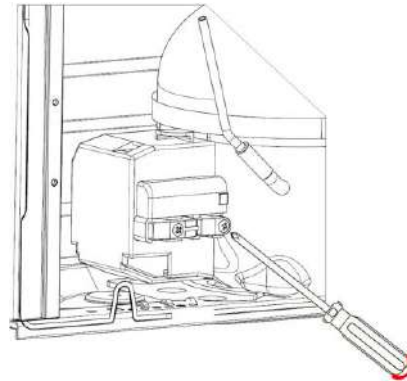

4-2) **Remove the metal clamp(for some models)**

- Disassembly the metal clamp that is fix the electric appliance shield

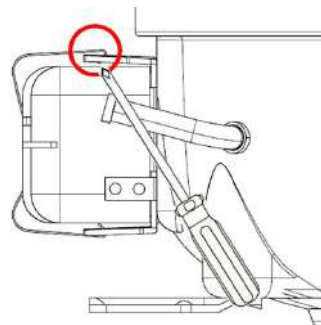

5) **Remove the clipping strip**

Slowly pull it out

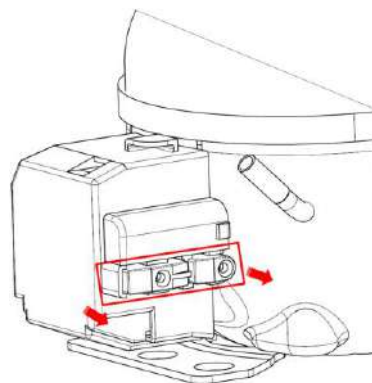

6) **Remove the protective cover**

- Pry the protective cover slowly from the upper part,
- Pull it out and remove it.

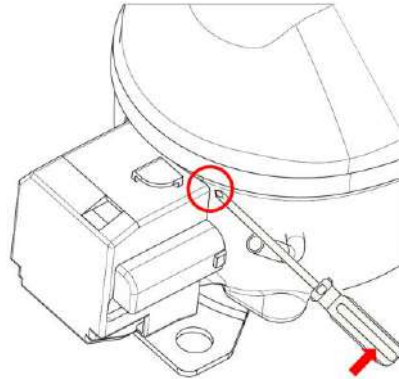

7) **Remove the starter and protector**

- Unplug the starter and protector (you can use a screwdriver to pry it slowly)

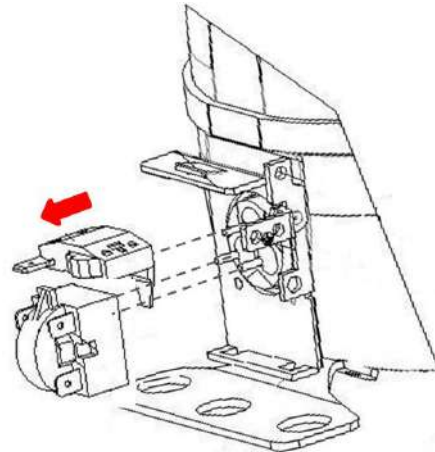

- 8) Loosen the screw of the compressor bottom plate, remove the floor together with the compressor from the box.

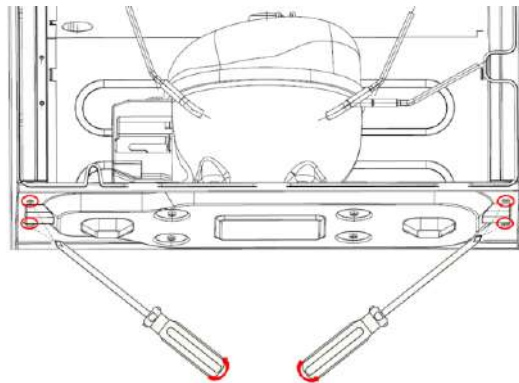

- 9) Use the wrench to remove the bolts by steps 4 5 6 7, replace the compressor and reverse process can complete installation.

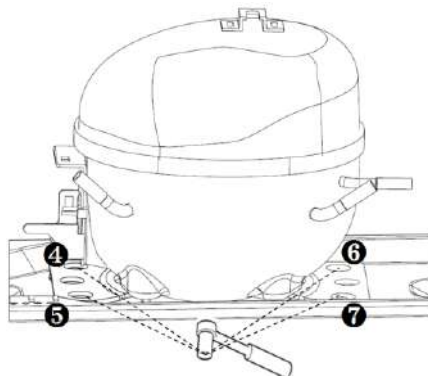

10) Use Pipe cutter cut off the condenser tube ⑧, then Shear off capillary ⑨ by the capillary tube scissors.

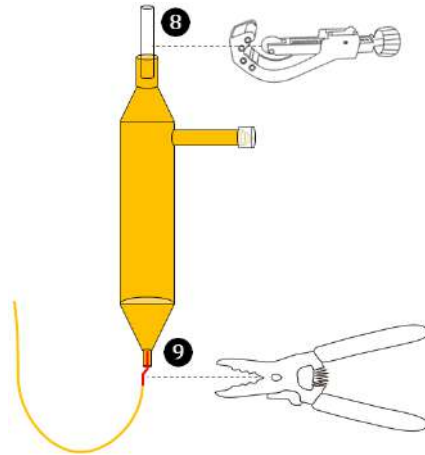

11) Replace the compressor and welding the compressor pipeline.-⑩Welding the process pipeline.-⑪Welding the low-pressure muffler.-⑫Welding the high-pressure exhaust pipe.

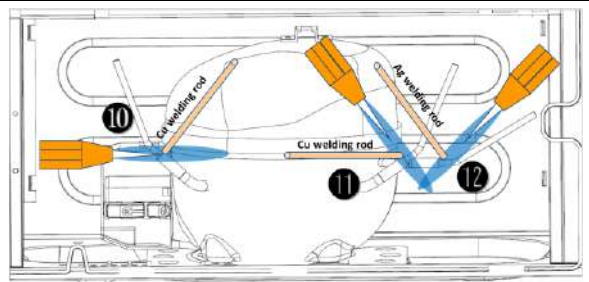

12) Replace the filter, Cu-Fe tubes welding ⑬ used Ag welding rod, Cu-Cu tubes welding ⑭ used Cu welding rod.

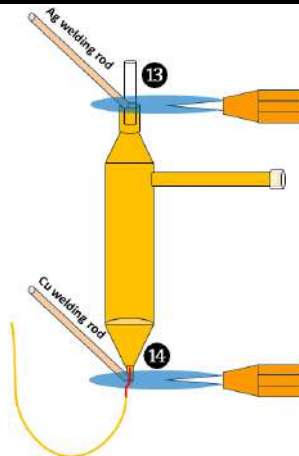

13) Vacuum system, The degree of vacuum below 6Pa.

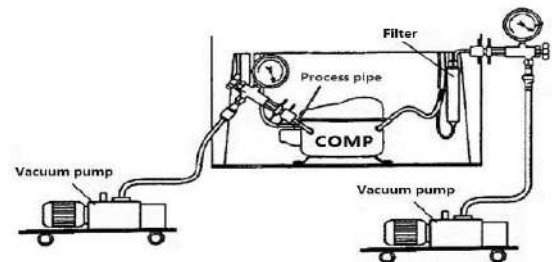

14) Perfusion refrigerant.

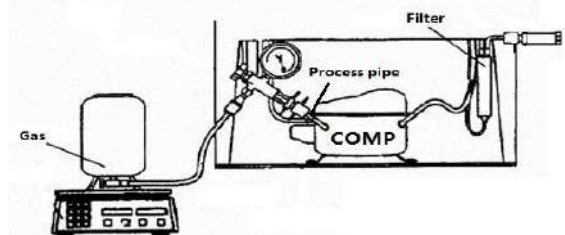

15) Use the vise grip pliers clamp the middle of the process pipe, then seal welding process tube 15 16.

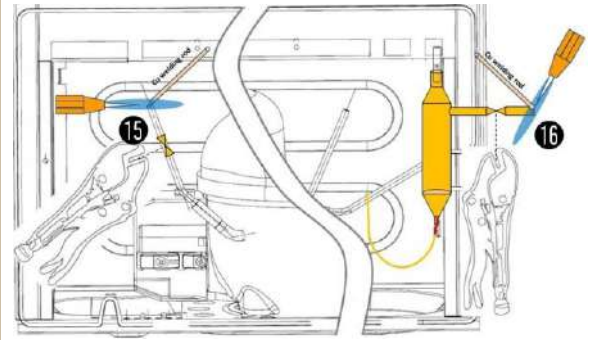

**Piping system in the compressor case**

- |                                 |                                   |
|---------------------------------|-----------------------------------|
| ①.Drain tray                    | ⑥.main control board box assembly |
| ②. condenser(enter)             | ⑦.compressor                      |
| ③.condenser(exit)               | ⑧.suction transition tube         |
| ④.anti-dew tupe assembly(exit)  | ⑨.Power wire                      |
| ⑤.anti-dew tupe assembly(enter) | ⑩.dry filter                      |

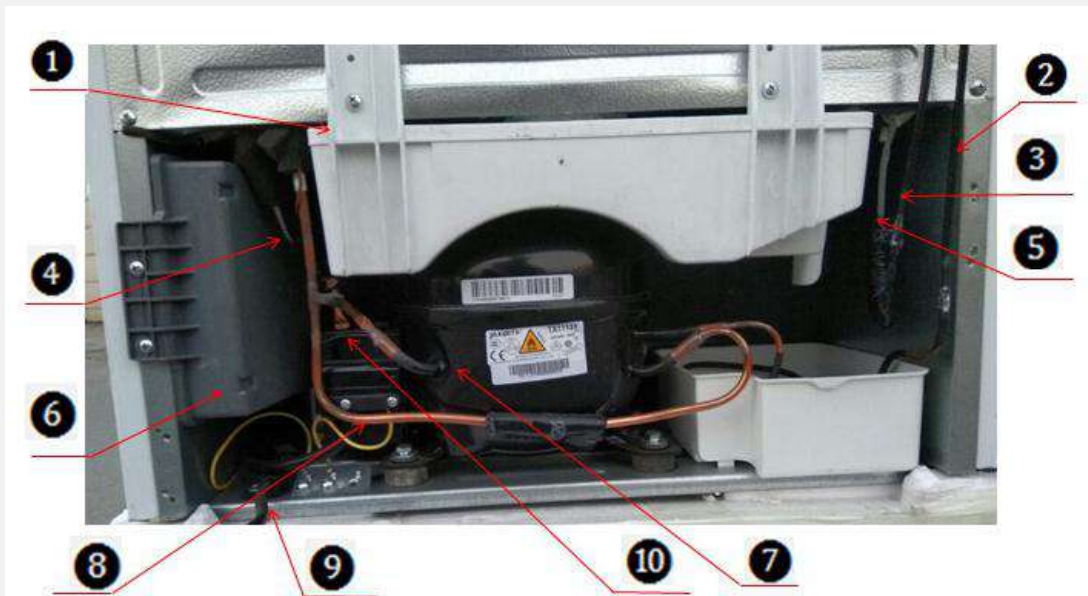

**Drain tray**

1) Disengage the drain tray buckle out of the compressor bottom plate installation hole.

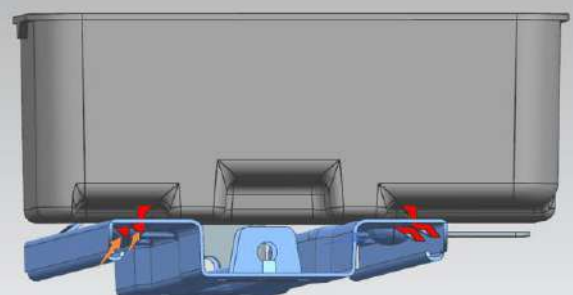

2) Replace the drain tray, the reverse process can complete installation.

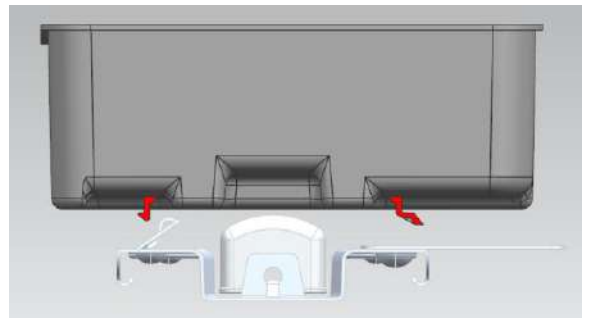

3) Remove the screws from the back of cabinet assembly

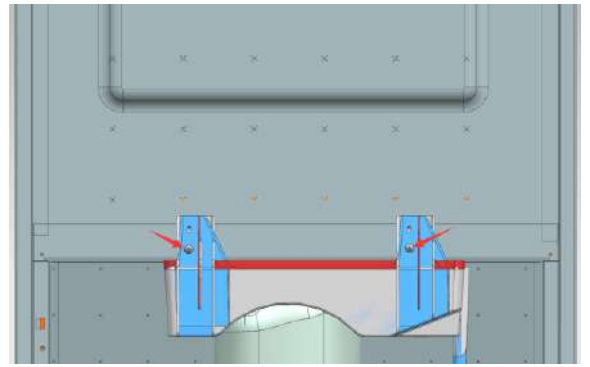

4) Replace the drain tray, the reverse process can complete installation.

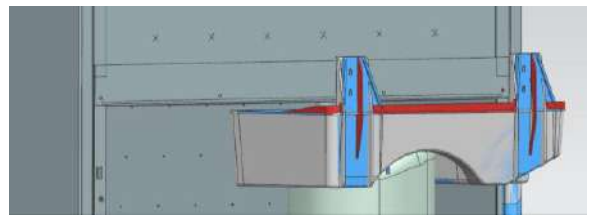

## **7.8 Display control board**

### **Display control board**

- 1) Pry open the buckle of the display control board installation box with a straight screwdriver
- 2) Pull all connector terminals out;
- 3) Remove 2 screws using a cross screwdriver to remove the display control board;
- 4) Replace the master control board in reverse steps;



## **7.9 Main control board**

### **Main control board**

- 1) The main control board box is located compressor case
- 2) Remove 2 screws using a cross screwdriver
- 3) Pry open the buckle of the main control board installation box with a straight screwdriver
- 4) Pull all connector terminals out and then remove the main control board
- 5) Replace the master control board in reverse steps.

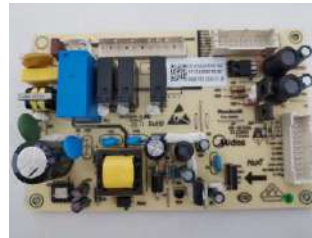

## 8. Temperature sensing system

### 8.1 Position of sensors

#### Position of sensors

Have 4 sensors

- ① Sensor in freezing chamber
- ② Sensor in refrigerating chamber
- ③ Sensor in Variable temperature chamber
- ④ Ambient temperature or humidity sensor
- ⑤ Ice machine sensor
- ⑥ Defrost sensor in refrigerating chamber
- ⑦ Defrost sensor freezing chamber

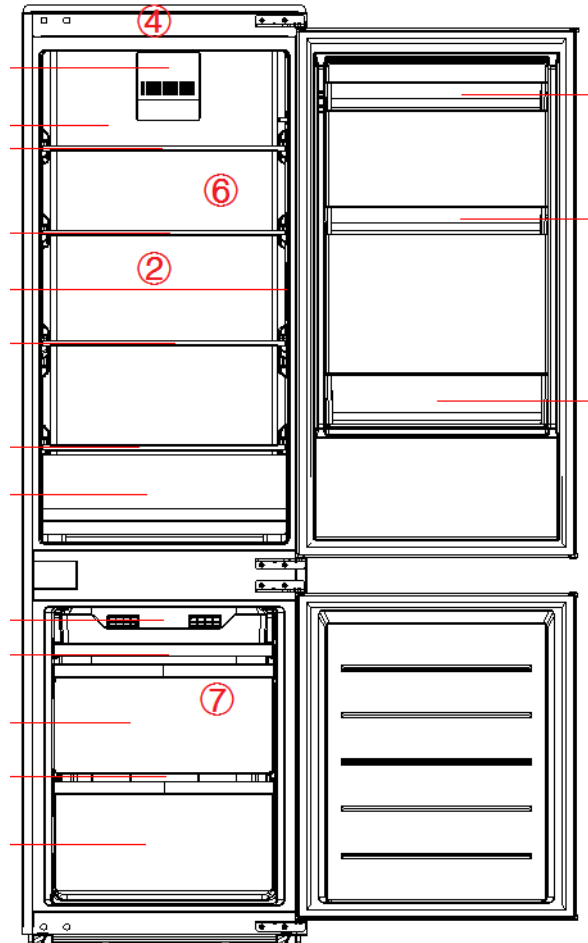

### 8.2 Replacement of sensors

#### Sensor

##### Sensor in refrigerating chamber

- 1) Before remove the sensor, the refrigerating duct assembly should be removed. Remove the air duct assembly from the refrigerating.
- 2) Remove the sensor.



**Defrost sensor in refrigerating chamber**

Before remove the sensor, the refrigerating duct assembly should be removed



**Ambient temperature sensor**

Sensor position in the upper of the box



**Defrost sensor**

The defrost sensor is located on top of the evaporator.

- 1) Disconnect the connector of defrost sensor
- 2) Cut off the band which fixes the sensor.
- 3) Separate the sensor and the evaporator.

\*Don't break the welding of the evaporator in case that only the sensor needs to be replaced.







**8.3 Sensor without terminal replacement**

**Sensor replacement guidelines**

Cut off the damaged head of sensor.

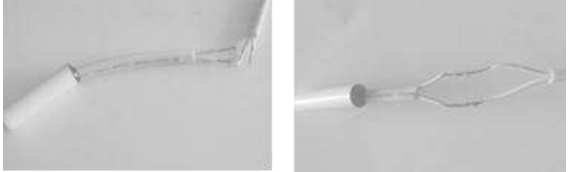

Strip off the sensor wiring.	
Take out a new sensor to cut the head of sensor. (Spare parts code: 11201007000795) Its technical specifications apply to all MIDEA refrigerators.	
Strip off the head of the sensor and connect it.	
Wrap the two wires together with insulation tape.	
Wrap the two wires together.	

### 8.4 Sensor resistance (R/T)

Tx(°C)	R (KΩ)	Tx(°C)	R (KΩ)	Tx(°C)	R (KΩ)	Tx(°C)	R (KΩ)	Tx(°C)	R (KΩ)
-30	33.81	-15	14.31	0	6.495	15	3.141	30	1.617
-29	31.85	-14	13.55	1	6.175	16	2.999	31	1.55
-28	30.01	-13	12.83	2	5.873	17	2.865	32	1.486
-27	28.29	-12	12.16	3	5.587	18	2.737	33	1.426
-26	26.68	-11	11.52	4	5.315	19	2.616	34	1.368
-25	25.17	-10	10.92	5	5.06	20	2.501	35	1.312
-24	23.76	-9	10.35	6	4.818	21	2.391	36	1.259
-23	22.43	-8	9.82	7	4.589	22	2.287	37	1.209
-22	21.18	-7	9.316	8	4.372	23	2.188	38	1.161
-21	20.01	-6	8.841	9	4.167	24	2.094	39	1.115
-20	18.9	-5	8.392	10	3.972	25	2.005	40	1.071
-19	17.87	-4	7.968	11	3.788	26	1.919	41	1.029

---

---

<b>-18</b>	16.9	<b>-3</b>	7.568	<b>12</b>	3.613	<b>27</b>	1.838	<b>42</b>	0.9885
<b>-17</b>	15.98	<b>-2</b>	7.19	<b>13</b>	3.447	<b>28</b>	1.761	<b>43</b>	0.9506
<b>-16</b>	15.12	<b>-1</b>	6.833	<b>14</b>	3.29	<b>29</b>	1.687	<b>44</b>	0.914

---

---

## 9. Function and operation

### 9.1 Display operation panel

Icons	Button
① One gear	⑤ Gear set button
② Two gear	
③ Three gear	
④ Four gear	

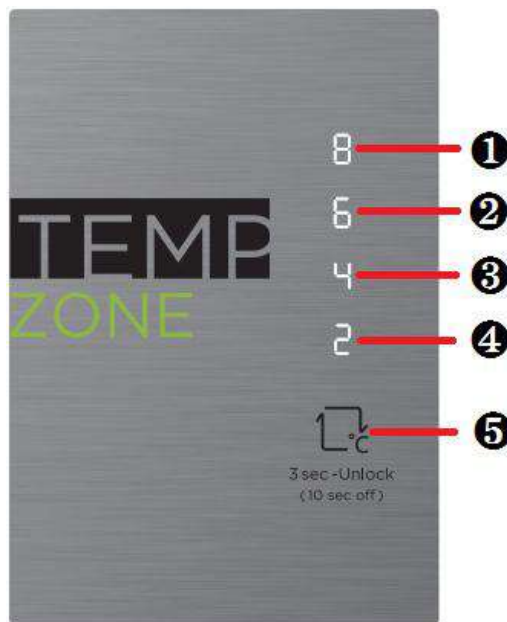

### 9.2 Display

At the first time of power-on, the display screen will be bright for 3 seconds and then according to the three gear to show operation

#### Normal operation display:

- 1) When failure occurs, the corresponding LED light group will display fault code (circular display);
- 2) If no failure occurs, the current operation gear will be displayed.

### 9.3 Setting of the gear

Press the **gear setting button 'SET'** once, the gear will be changed once; 30 seconds after setting the gear, the refrigerator will be running in accordance with the set value.

The gear can be set to: (Setting the gear from one to four the set temperature will be lower to higher and it can be set circularly)

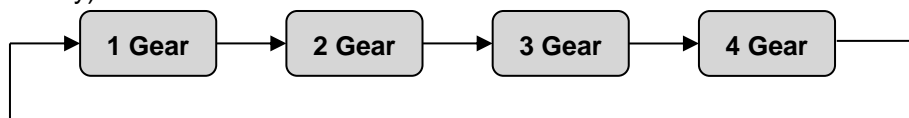

## **9.4 lock and unlock Settings**

In the lock state, long press the SET key for 3 seconds to unlock the device before it can operate. When the unlock is effective, all LED lights will flash for 2 times. In the lock state, all LED lights will flash for 2 seconds to remind the user to unlock the device first.

In the unlocking state, no operation of the button for 30 seconds will automatically lock, no manual lock.

## **9.5 memory function**

Power off memory function of the control device, memory contents:

Refrigerator setting temperature: set the gear

Standby mode

Super freezing mode

Press total run time (when power on freezing frost sensor temperature greater than 8 °C, press total run time).

## **9.6 Control of standby function**

9.6.1 entry mode:

In the unlocking state, set the key STE for 10S (when the display and control of the refrigerator are all off, the standby button will take effect when the key is released). After 30S, the refrigerator will enter the standby function mode, and the display and control of the refrigerator will be all off in the standby mode.

9.6.2 exit method:

In standby mode, press the SET key to exit the standby mode and the refrigerator will return to normal con

## **9.7 Open door alarm (None)**

## **9.8 Function selection (None)**

## **9.9 Fault code and solutions**

Fault code	Display	Failure Type	Solution
E1	④档“On” of LED1(④Gear) simultaneously	Temperature sensor fault in refrigerating chamber	<p>Step 1: Check whether the terminal CN8 is well stuck, pull out the terminal and re-stick it in place</p> <p>Step 2: Check to see if there are foreign matters on the terminal. Pull out the refrigerating sensor according to the method in described in Article 8.5 and then inspect the sensor against the resistance value table in 10.8.</p> <p>Step 3: Replace main control board</p> <p>Step 4: Replace electrical wiring main harness</p>
E4	③档“On” of LED2(③Gear) simultaneously	Fault of R defrost sensor	<p>Step 1: Check whether the terminal CN8 is well stuck, pull out the terminal and re-stick it in place</p> <p>Step 2: Check to see if there are foreign matters on the terminal. Pull out the</p>

			refrigerating sensor according to the method in described in Article 8.5 and then inspect the sensor against the resistance value table in 10.8. Step 3: Replace main control board Step 4: Replace electrical wiring main harness
E5	②档“On” of LED3 (②Gear)simultaneously	Fault of F defrost sensor	Step 1: Check whether the terminal CN8 is well stuck, pull out the terminal and re-stick it in place Step 2: Check to see if there are foreign matters on the terminal. Pull out the defrost sensor in freezing chamber according to the method in described in Article 8.5 and then inspect the sensor against the resistance value table in 10.8. Step 3: Replace main control board Step 4: Replace electrical wiring main harness
E7	①档“On” of LED4(①Gear) simultaneously	Ambient temperature sensor fault	Step 1: Check whether the terminal CN8 of main control board is well stuck, pull out the terminal and re-stick it in place Step 2: Check to see if there're foreign matters on the terminal. Pull out the defrost sensor in freezing chamber according to the method in described in Article 8.5 and then inspect the sensor against the resistance value table in 10.8. Step 3: Replace main control board Step 4: Replace electrical wiring main harness

**9.10 Defrosting function**

1.Defrost the freezing chamber as per the accumulative operation time of the Compressor2.If power failure occurs abruptly to the Compressor and the defrosting sensor in freezing chamber is less than 0°C after powering on, then first conduct defrosting once. If more than 0°C, then defrosting is not needed. After that, conduct defrosting according to using condition and ambient temperature in a period between 6 and 24 hours as per the accumulative operation time of the Compressor.

**9.11 Test mode**

Test items	Testing Method	Expected result
Enter Test Mode	The LED lights indicate ON means changing it to flashing mode after press “SET” key 20s under the condition of temperature adjustment. After that, press “SET” key 7s to enter to forced operation mode.	The refrigerator enters into testing mode when the LED lights are off
	After entering into test mode, if no button is pressed within 25 seconds	then the refrigerator will exit the test mode and return to normal operation mode
Select to	Enter into test mode and press	LED indicators on Gear 1, 2 light up and other

enter into forced cooling mode	button for the second time	LED indicators light off, then the compressor and the fan will start working
	In forced cooling mode, if no button is pressed within 36 hours,	then the refrigerator will exit the test mode and return to normal operation mode
Select to enter into forced compensating heating mode	Enter into test mode and press button for the first time	LED indicators on Gear 3, 4 light up and other LED indicators light off, then the compensating heater will start working
		then the refrigerator will exit the test mode and return to normal operation mode
Select to enter into forced defrosting mode	Enter into test mode and press button for the third time	LED indicators on Gear 1, 4 light up and other LED indicators light on, then the compressor and the fan will stop working, The heater open, refrigerator into forced frost
	In forced defrosting mode, when the defrosting sensor reach a temperature of 8°C and the defrosting heater has been working for 2 minutes,	then the refrigerator will exit the test mode and return to normal operation mode
	In forced defrosting mode, if the temperature of defrosting sensor is always lower than 8°C and the defrosting heater has been working for 1 hour,	then the refrigerator will exit the test mode and return to normal operation mode
Select to exit the test mode	Enter into test mode and press button for the third time	then the refrigerator will exit the test mode and return to normal operation mode

## 10. Compressor

---

### 10.1 Compressor on and off Control specifications

1.1 When one of the following conditions is met, the compressor stops:

- 1)  $Tr \leq Trt$ ;
- 2) The compressor runs continuously for more than 3 hours (Stop 5 minutes);

1.2 When all the following conditions are met, the compressor starts up:

- 1)  $Tr \geq Trk$ ;
- 2) Compressor downtime is more than 5min.

★When 1.1 and 1.2 are not satisfied, the compressor maintains the original state

## 11. Troubleshooting Method

### 11.1 No cooling (Air cooling-Electronic)

#### No cooling of F room and R room

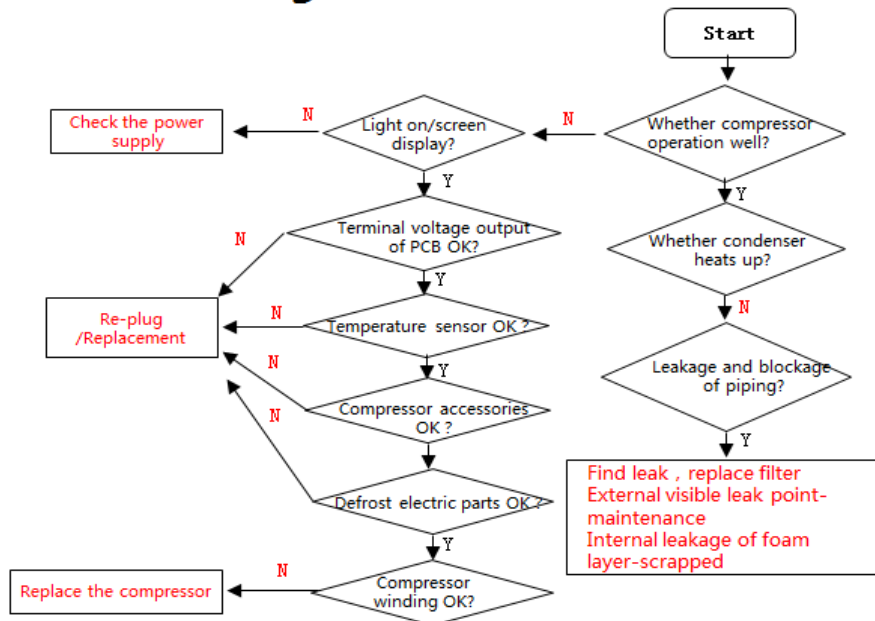

#### F room cooling, R room no cooling

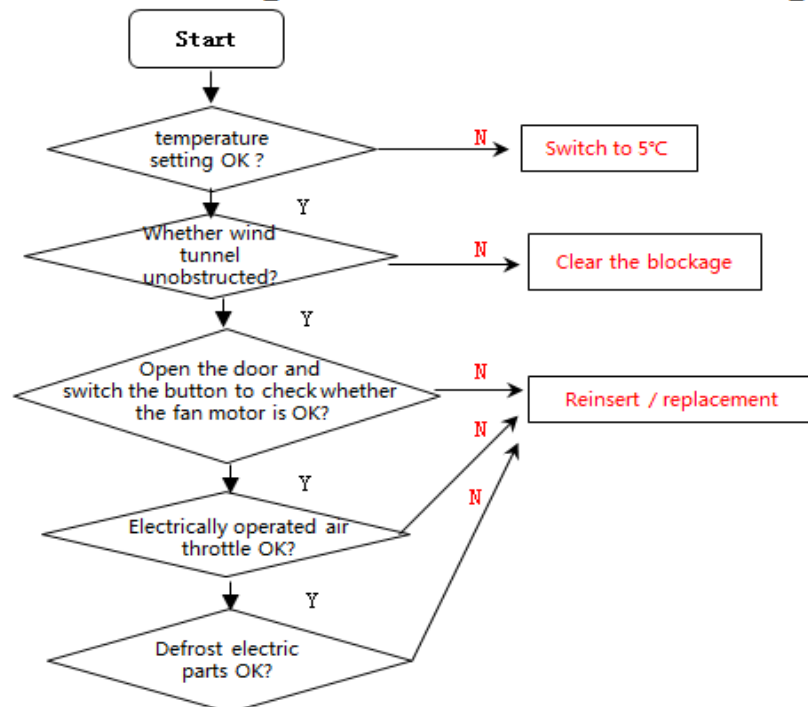

### 11.2 No working of compressor

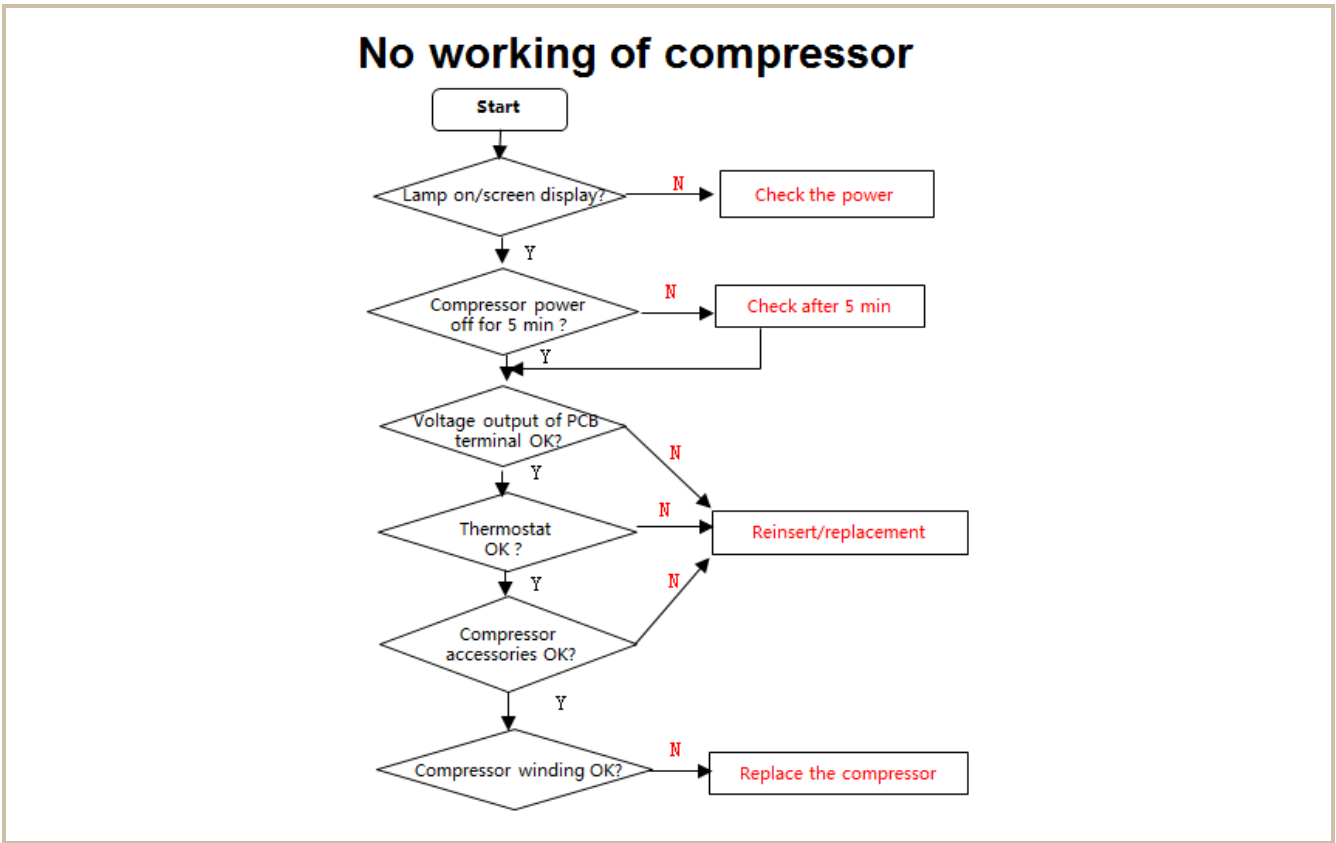

### 11.3 Inside frosting, no defrosting

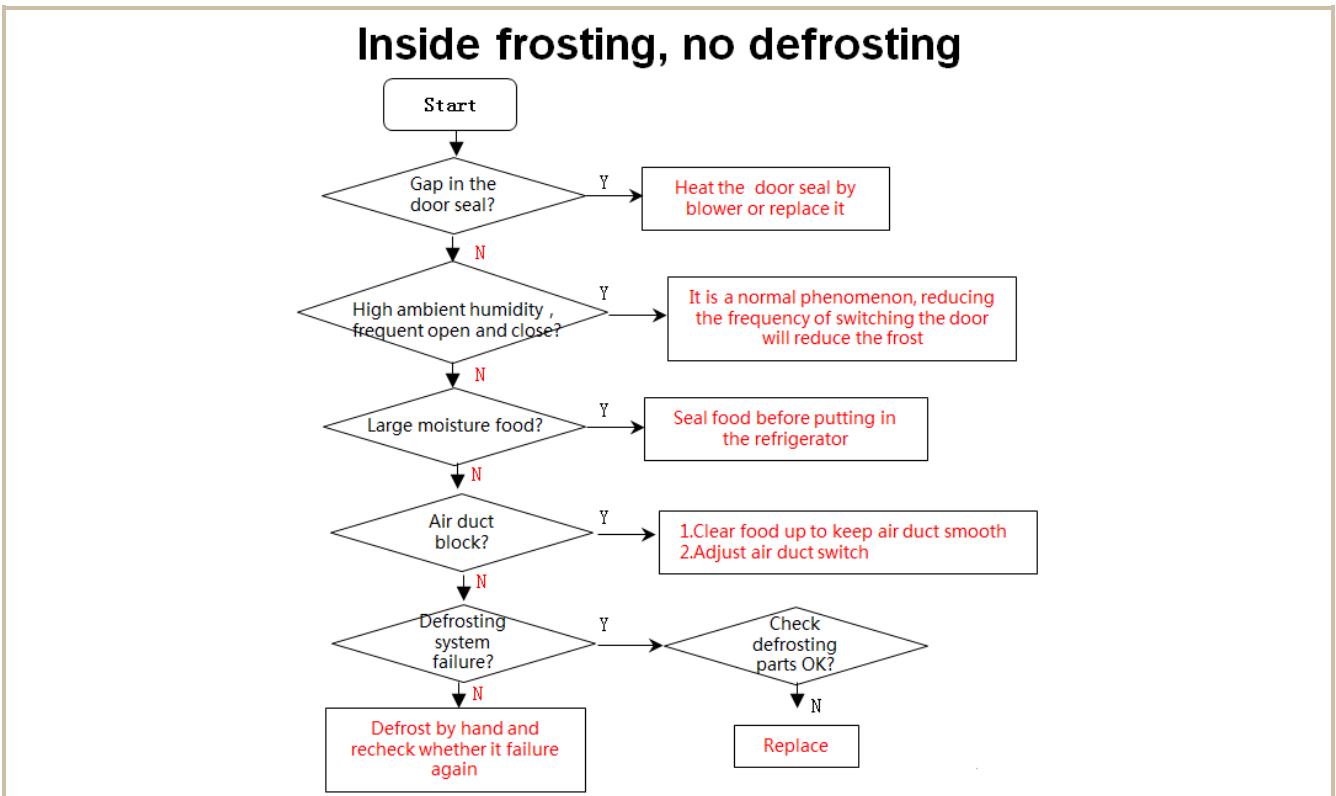

**11.4 Inside frosting, no defrosting-Maintenance guidelines**

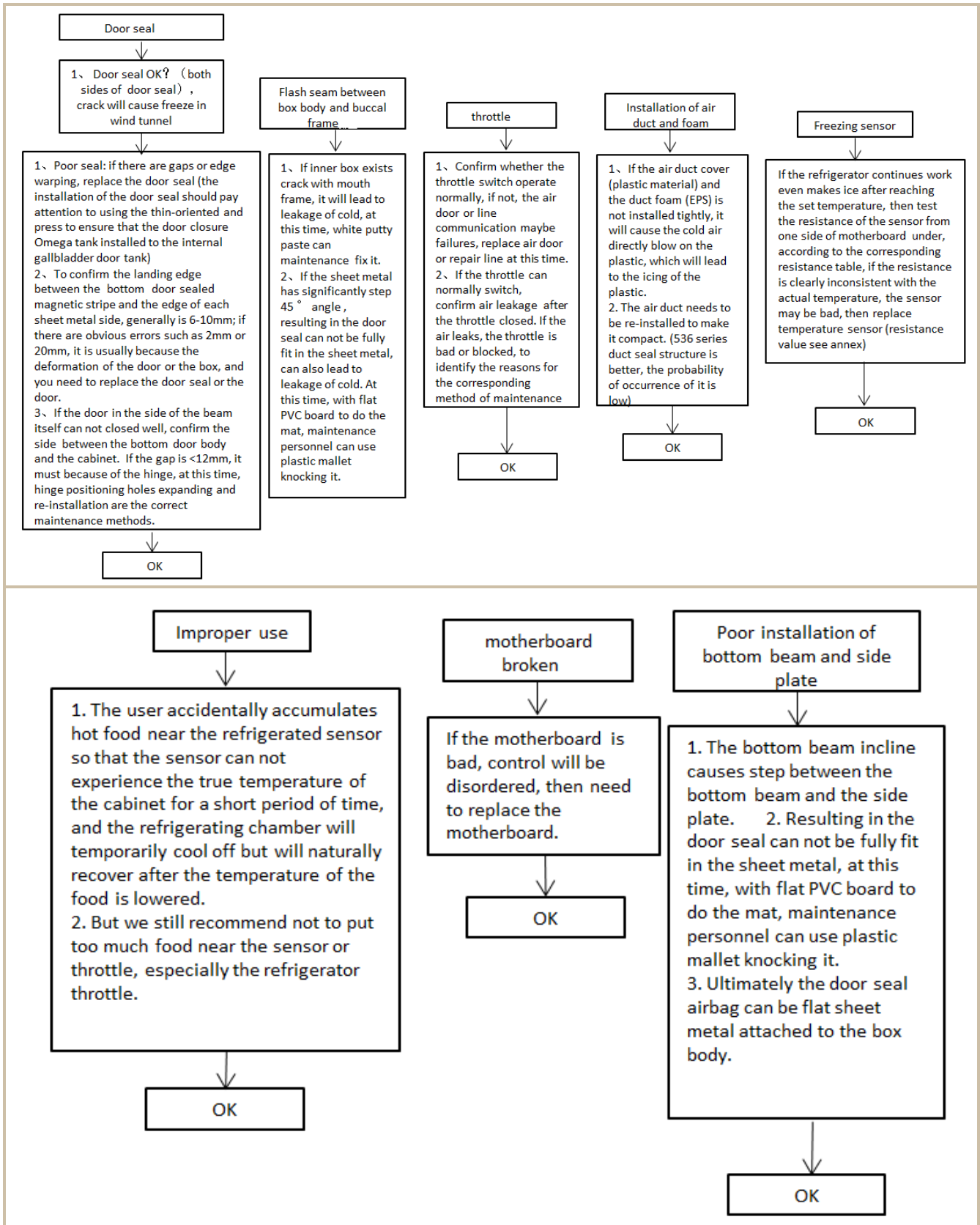

## 11.5 Light is not on

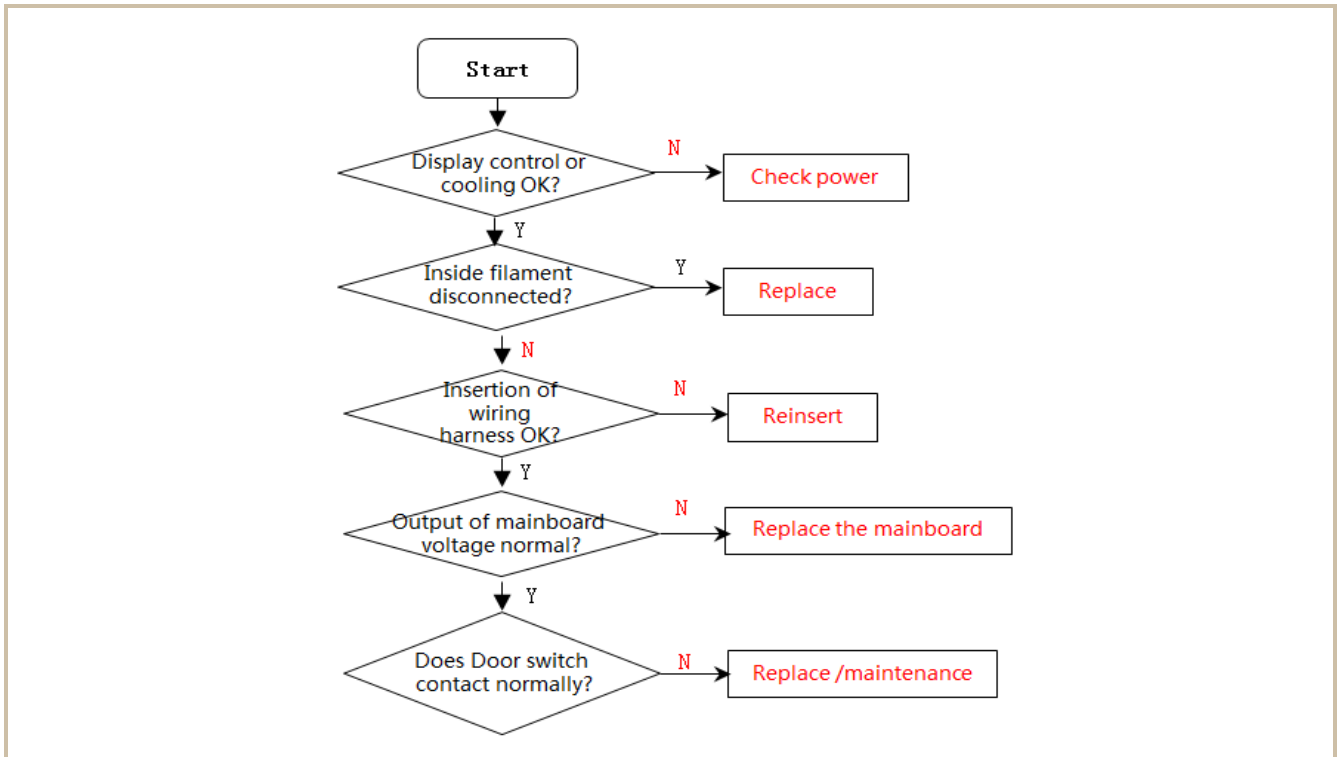

## 11.6 Fan failure

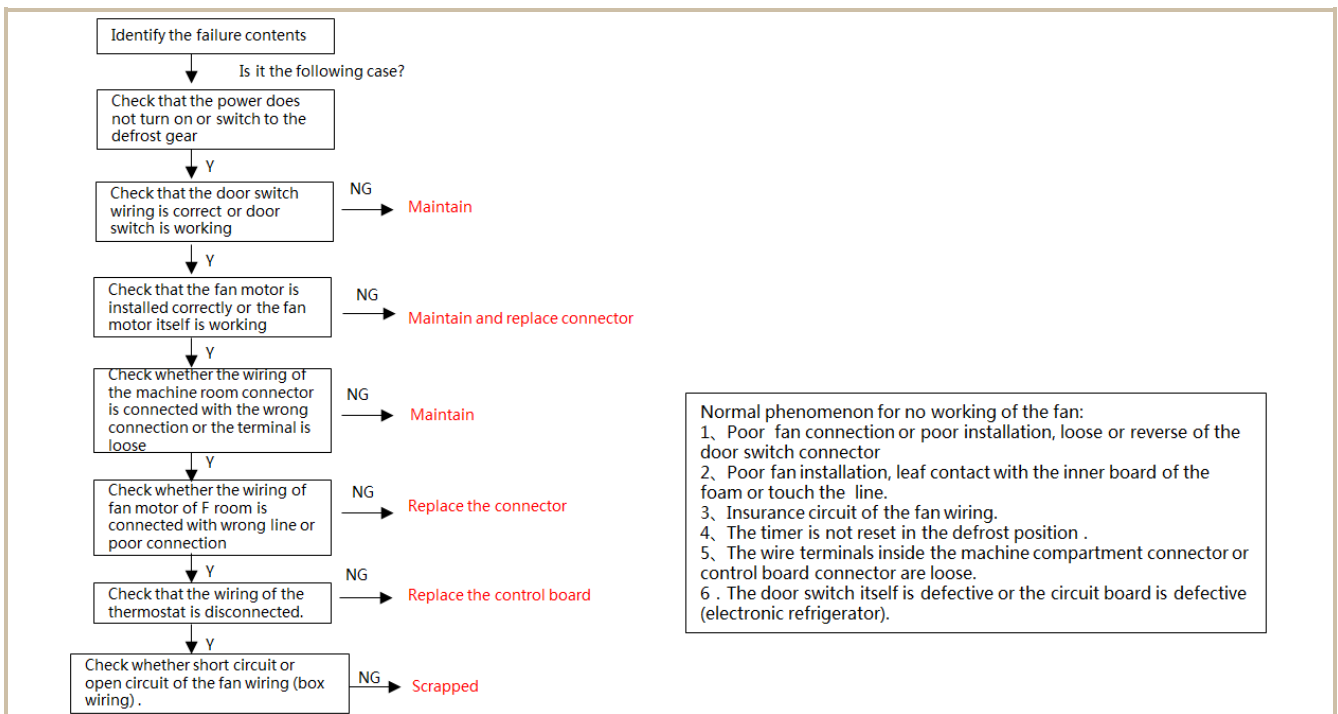

### 11.7 Defective defrost circuit

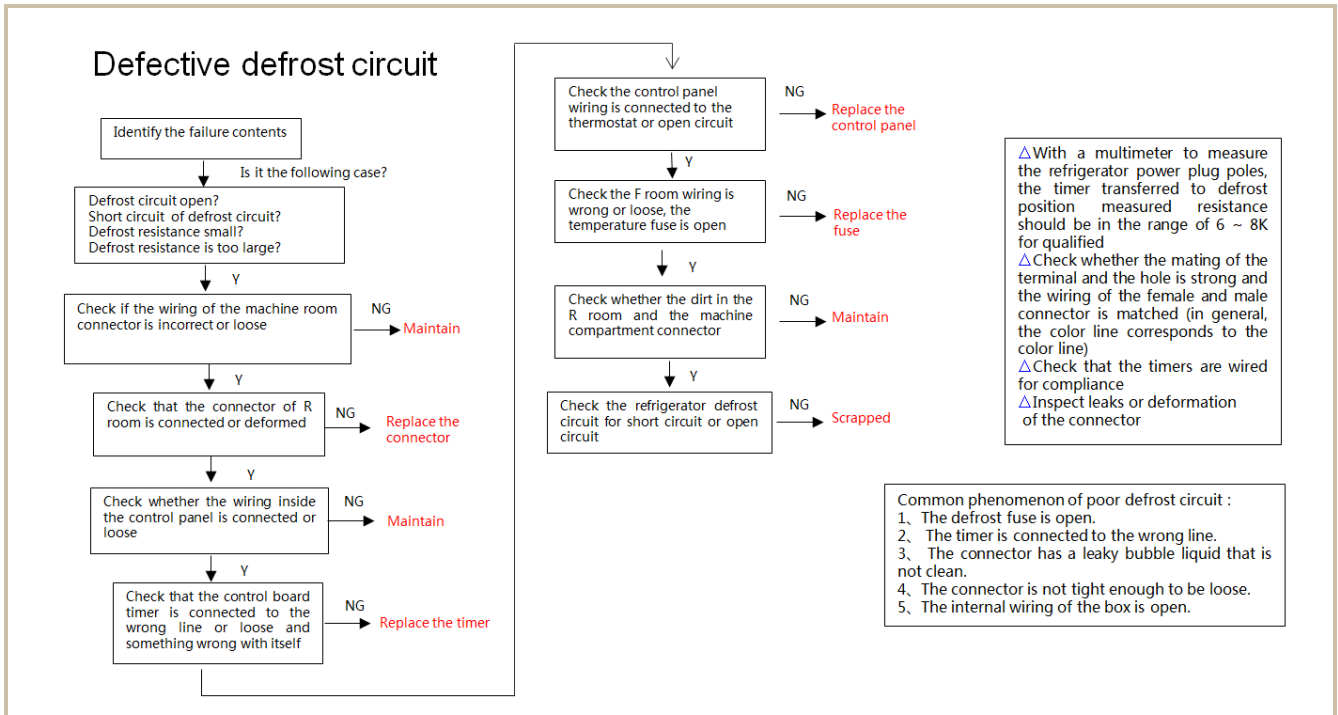

### 11.8 Noise

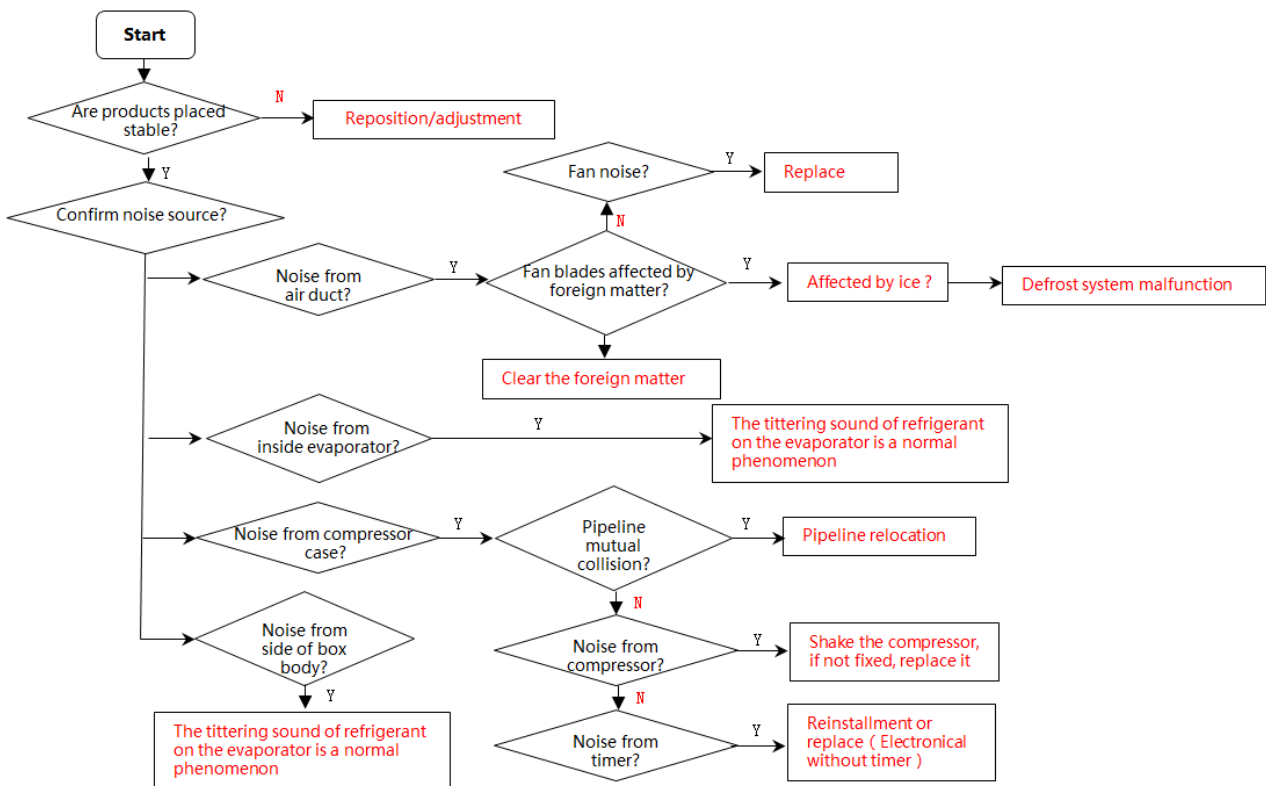

**11.9 Air duct not operated (electronically) (None)**

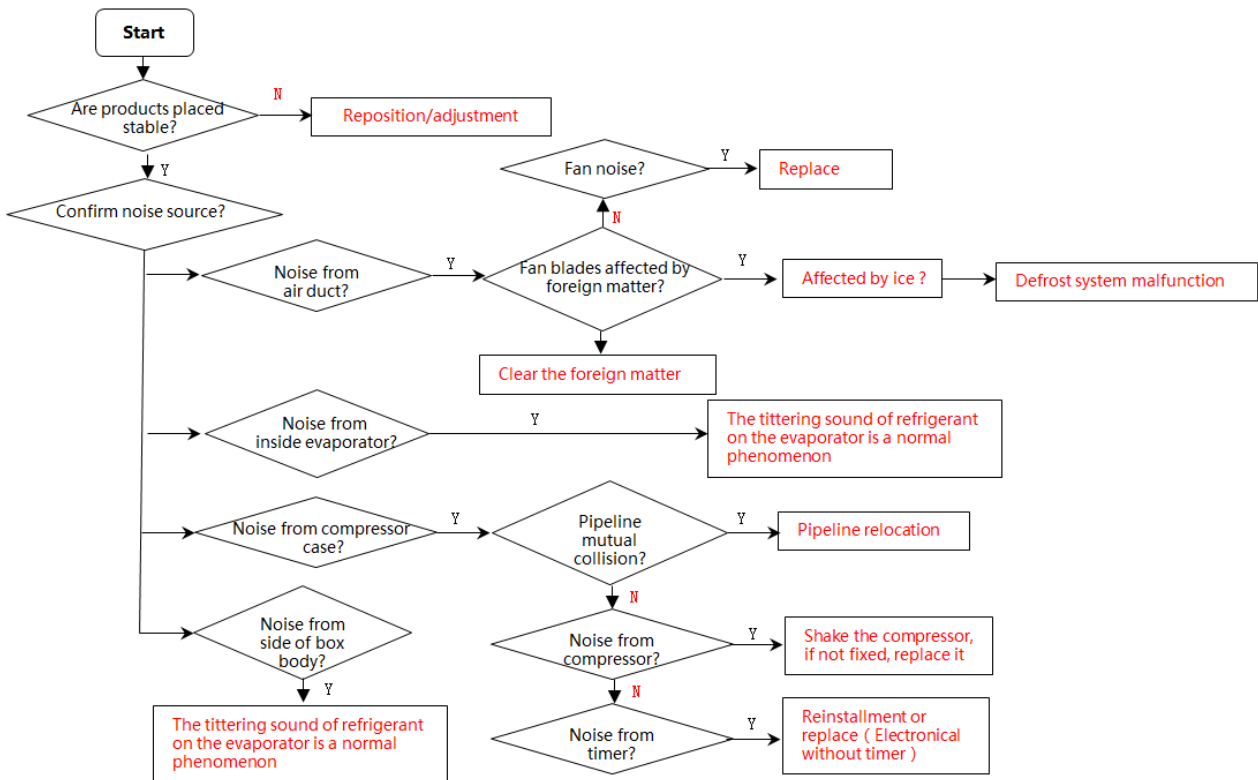

## 12. Figures and details of repair parts

---

Please log in to TSP system to view and download these contents.

### Entry Guidelines ( TSP System )

■ Where



<https://tsp.midea.com>

■ How

International users or customers:

**Account:** MC\*\*\*\*\* (provided by TSP administrator or Sales Manager).

*If you buy different categories from Midea group, you can see all the product information by one account.*

**Preliminary password:** Please contact the TSP administrator or sales manager for the password.

*If the input error more than 5 times, account will be locked, need contact the administrator to unlock.*



**Administrator:**

REF: Jamie Liu([liujc5@midea.com](mailto:liujc5@midea.com))



The symbol on the product or its packaging indicates that this product must not be disposed of with your other household waste. Instead, it is your responsibility to dispose of your waste equipment by handing it over to a designated collection point for the recycling of waste electrical and electronic equipment. The separate collection and recycling of your waste equipment at the time of disposal will help conserve natural resources and ensure that it is recycled in a manner that protects human health and the environment. For more information about where you can drop off your waste for recycling, please contact your local authority, or where you purchased your product.



### **MIDEA appliances after sales website**

For more information about Midea appliances after sales, please visit the [tsp.midea.com](https://tsp.midea.com)  
For more information about the service manual, please visit the [tsp.midea.com](https://tsp.midea.com)  
For more information about the EV and SBOM, please visit the [tsp.midea.com](https://tsp.midea.com)



### **How to login TSP system**

Use Google browser visit the <https://tsp.midea.com/>

#### **Internal User:**

Use MIP account and Password.

#### **Customer:**

Access: Generated by TSP (provided by administrator).

Password: abcd1234 (please revise after login in).

## **Midea Refrigerators**

If you need to get detailed technical information from the manufacturer, please contact:

**xxx@midea.com**

**Refrigeration Division  
Overseas Sales Company**

Address: No. 176, Jinxiu Avenue, Economic-Technological Development Area, Hefei, Anhui, China