

Refrigerator
TWO DOOR SERIES



SmartHome



Download the app
& activate product

USER MANUAL

MRU21C7BST
MRU21C7BWW

Warning notices: Before using this product, please read this manual carefully and keep it for future reference. The design and specifications are subject to change without prior notice for product improvement. Consult with your dealer or manufacturer for details.
The diagram above is just for reference. Please take the appearance of the actual product as the standard.

THANK YOU LETTER

Thank you for choosing Midea! Before using your new Midea product, please read this manual thoroughly to ensure that you know how to operate the features and functions that your new appliance offers in a safe way.

CONTENTS

THANK YOU LETTER	03
SPECIFICATIONS	04
PRODUCT OVERVIEW	05
PRODUCT INSTALLATION	06
OPERATION INSTRUCTIONS	15
APP SETUP AND OPERATION	19
CLEANING AND MAINTENANCE	20
TROUBLESHOOTING	21
DOC AND CERTIFICATIONS	23

SPECIFICATIONS



Wireless Network module model	MWB-S-WB01
Standard	IEEE 802.11b/g/n
Antenna Type	Printed PCB antenna
Frequency Band	2400-2483.5 MHz
Operating Temperature	0 °C - 85 °C /32 °F-185 °F Operation humidity: 10%-85%
Power Input	DC5V/500mA Maximum Transmission power: <20dBm

PRODUCT OVERVIEW

Names of components

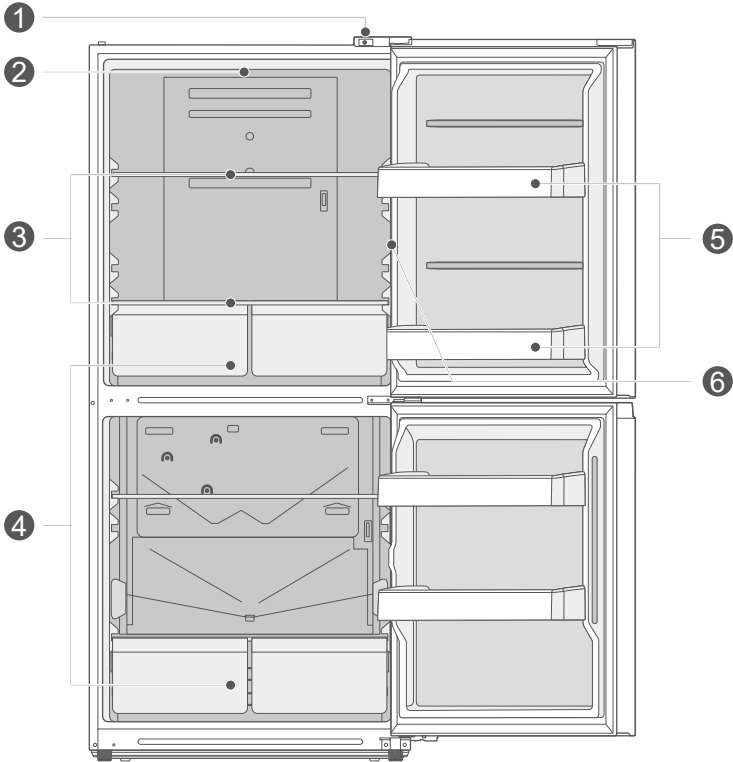

- | | | | |
|----------|-------------|----------|---------------|
| 1 | Door switch | 4 | Drawer |
| 2 | LED light | 5 | Door tray |
| 3 | Shelf | 6 | Control panel |

ATTENTION

The picture above is only for reference. Wire drawers cannot be used as fruits and vegetables, and there is a risk of frostbite. The actual configuration will depend on the physical product or statement by the distributor.

PRODUCT INSTALLATION

Install Instruction

Finding a suitable location

- > This refrigerator is designed to be free standing only, and should not be recessed or built-in.
- > The refrigerator should be placed in a well-ventilated indoor place; the ground shall be flat and sturdy.
- > Keep away from heat and avoid direct sunlight. Do not place the refrigerator in moist or watery places to prevent rust or reduction of insulating effect.

Dimensions and Clearances

- > Too small of a distance from adjacent items may result in the degradation of freezing capability and increased electricity costs. The refrigerator both sides should be placed against the wall with a free distance more than 100mm, and the refrigerator back against the wall distance not more than 75mm.

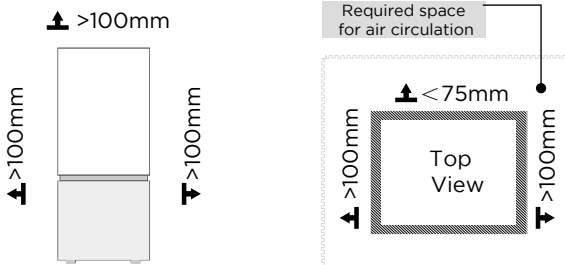

Providing a proper power supply

- > Check your local power source. This refrigerator requires a 115 V, 60 Hz power supply.
- > Use a receptacle that accepts the grounding prong. The power cord is equipped with a 3-prong (grounding) plug which mates with a standard 3-prong (grounding) wall outlet to minimize the possibility of electric shock hazard from this refrigerator.



CAUTION

The freezer should always be plugged into its own individual electrical outlet which has a voltage rating that matches the rating plate.

Never unplug your freezer by pulling on the power cord. Always grip the plug firmly and pull straight out from the outlet.

Start to use

- > The freezer shall stay for half an hour before connecting power when it is firstly started.
- > The freezer shall run 2 to 3 hours before loading fresh or frozen foods; the freezer shall run for more than 4 hours in summer in advance considering that the ambient temperature is high.

Space requirement diagram (when the door is open and when the door is closed)

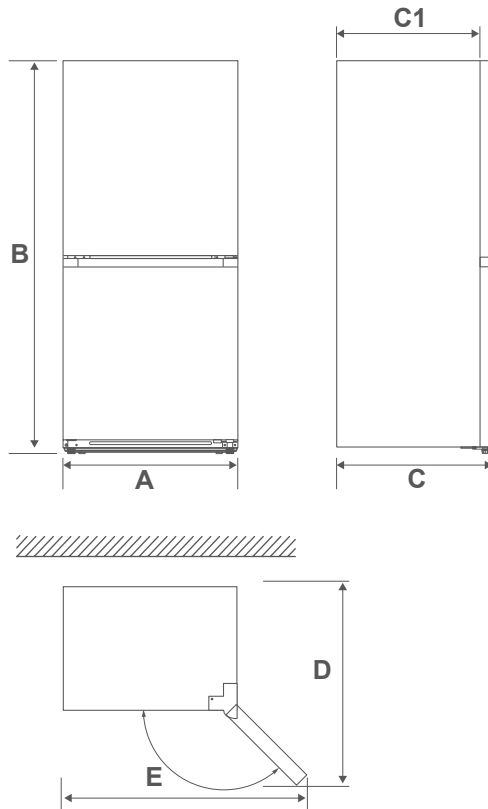

Width	Overall Height	Depth	Without door	Depth doors open 135°	Width doors open 135°
A	B	C	C1	D	E
755	1692	830	734	1351	1275

Notice: All dimensions in mm

Door reversal (Optional)

Based on the location where you plan to use your refrigerator, you may find it more convenient to reverse the position of the door.

⚠ CAUTION

To avoid injury to yourself or your property, we recommend that someone assist you during the door reversal process.

Preparing to reverse the door position

You will need: A flathead screwdriver, a Phillips screwdriver, and the included Allen wrench..

- > Make sure that your refrigerator is unplugged and empty.
- > Have someone available to assist you in the process.
- > Keep all of the parts you remove to reuse them later.

Parts included with the hinge kit:

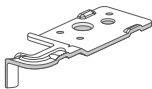

Left upper hinge

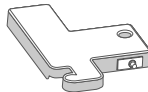

Left upper hinge cover

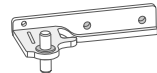

Left middle hinge



Top door left self-lock

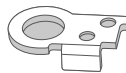

Top door left stopper

Parts already mounted on the door (as shipped):

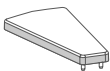

Hole cover



Upper hinge shaft sleeve



Middle hinge Shaft sleeve



Lower hinge shaft sleeve

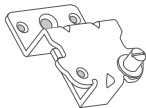

Lower hinge



Bottom door self-lock

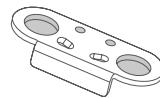

Bottom door Stopper

Parts currently open on the right side:



Right upper hinge



Right upper hinge cover

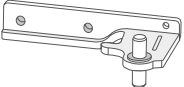

Right middle hinge



Top door right self-lock

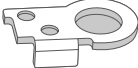

Top door right stopper

STEP:

- 1.** Power off the refrigerator and remove all food items from the door shelves. Secure the door with tape.

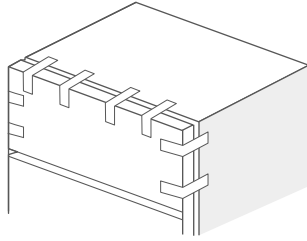

- 2.** Remove the left hole cover and the right upper hinge cover with a Phillips and flathead screwdriver, remove the upper hinge, and save the screws for use.

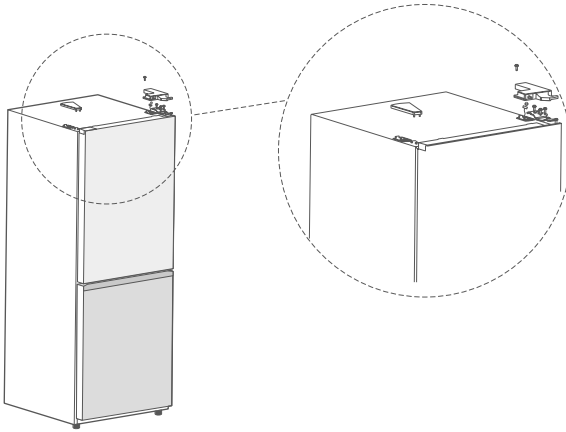

- 3.** Remove the upper door body.
- 4.** Remove the middle hinge and screw cover with a Phillips screwdriver, and then remove the lower door body from the refrigerator's body upward, and save the bolts for use.

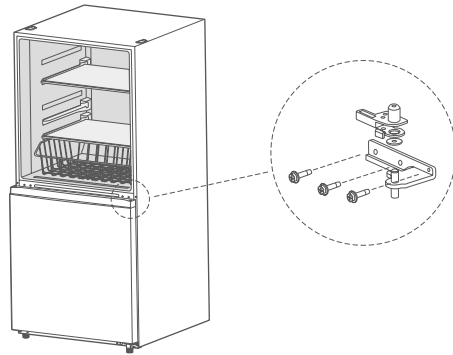

5. Remove the right lower hinge screws, and then remove the lower hinge and adjustable feet. Pry off the insert pin, screw cap and adjustable feet on the left side and remove the screw.
6. Remove the lower hinge shaft and move it to the left of the lower hinge and tighten it, then install the removed right lower hinge to the left lower end of the refrigerator and secure it with the screws that were kept aside.

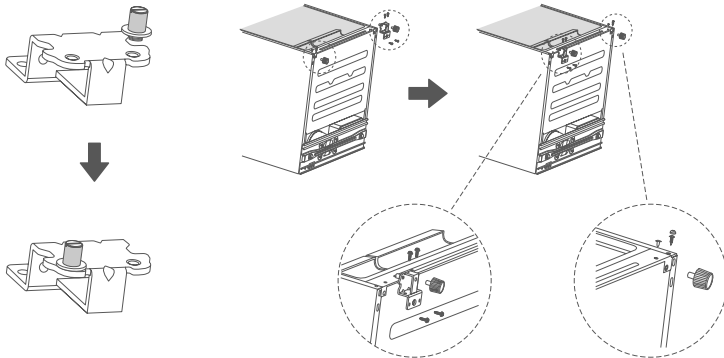

7. Remove the shaft sleeves at the right end of the lower door body and the upper door body and the hole cover on the shaft hole at the left end of the lower door, and install them on the opposite side.
8. Remove the door stop at the lower right end of the lower door body and install it on the opposite side of the door body. Remove the door stop and self-lock at the lower right end of the upper door body and save it, remove the left stop and self-lock in the accessory package of the machine and install them on the upper door body.

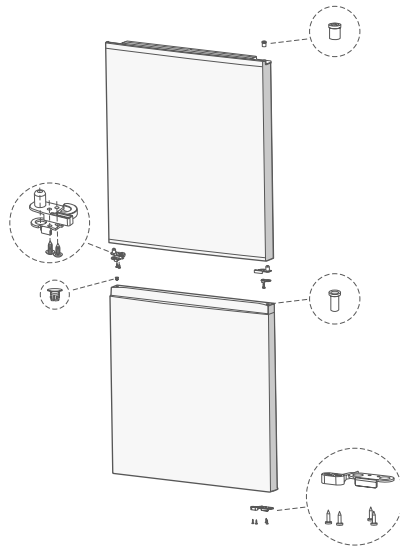

- 9.** Install the lower door onto the lower hinge, and Pry off the insert pin, screw cap and remove the screw, remove the middle hinge on the other side from the accessory package and install the middle hinge on the opposite side.

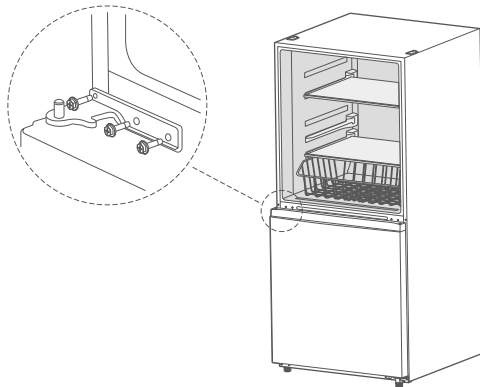

- 10.** Remove the other side's upper hinge cover from the accessory package, remove the switch installed on the right hinge cover and install it on the left upper hinge cover; install the upper door body on the left middle hinge and install the left upper hinge; connect the switch on the left hinge cover of the refrigerator, cover and fix the left hinge cover, and finally install the hinge cover decorative cover to the right side of the refrigerator's body. After installation, let stand for at least 2 hours

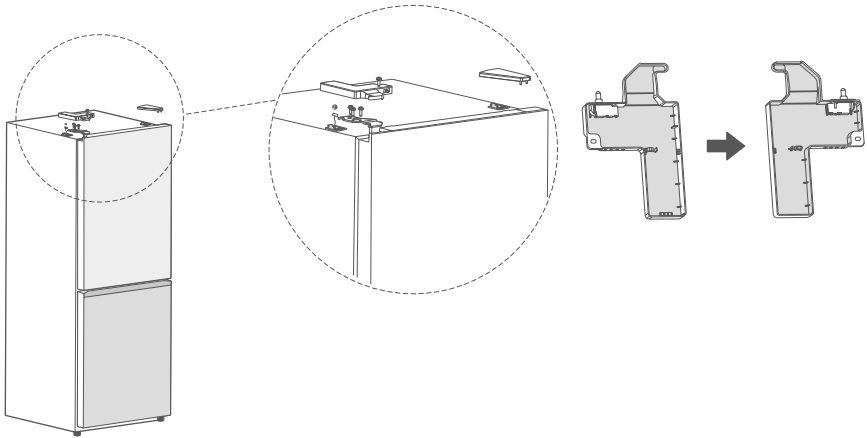



Leveling feet

To avoid vibration, the unit must be leveled.

If required, adjust the leveling screws to compensate for the uneven floor.

The front should be slightly higher than the rear to aid in door closing.

Leveling screws can be turned easily by tipping the cabinet slightly.

Turn the leveling screws counterclockwise  to raise the unit, clockwise  to lower it.

Moving the appliance

1. Remove all food from inside the appliance.
2. Pull the power plug out, insert and fix it into the power plug hook at the rear or on top of the appliance.
3. Tape parts such as shelves and the door handle to prevent from falling off while moving the appliance.
4. Move the appliance with more than two people carefully. When transporting the appliance over a long distance, keep the appliance upright.
5. After installing the appliance, connect the power plug into a socket out to switch on the appliance.

ATTENTION

Precautions before operation:

Before making changes the refrigerator must be disconnected from power. precautions should be taken to prevent any personal injury.

Changing the light

- > Any replacement or maintenance of the LED lamps is intended to be made by the manufacturer, its service agent or similar qualified person.

Connecting the appliance

After installing the appliance, connect the power plug into a socket outlet.

ATTENTION

After connecting the power supply cord (or plug) to the outlet, wait 2 or 3 hours before you put food into the appliance. If you add food before the appliance has cooled completely, your food may spoil.

Tips for energy saving

- > Do not place the appliance near cookers, radiators or other heat sources. If the ambient temperature is high, the compressor will run more frequently and for longer, resulting in increased energy consumption.
- > Ensure that there is sufficient ventilation at the base of the appliance, on the sides of the appliance and at the back of the appliance. Never cover ventilation openings.
- > Please also observe the spacing dimensions in the chapter "Installation".
- > The arrangement of drawers, shelves and racks as shown in the illustration offers the most efficient use of energy and should therefore be retained as far as possible. All drawers and shelves should remain in the appliance to keep the temperature stable and save energy.
- > To obtain a larger storage space (e.g. for large refrigerated/frozen goods), the middle drawers can be removed. The top and bottom drawers and shelves should be removed last if necessary.
- > An evenly filled refrigerator/freezer compartment contributes to optimal energy use. Therefore, avoid empty or half-empty compartments.
- > Allow warm food to cool before placing it in the refrigerator/freezer. Food that has already cooled down increases energy efficiency.
- > Allow frozen food to defrost in the refrigerator. The coldness of the frozen food reduces the energy consumption in the refrigerator compartment and thus increases the energy efficiency.
- > Open the door only as briefly as necessary to minimise cold loss. Opening the door briefly and closing it properly reduces energy consumption.
- > The door seals of your appliance must be perfectly intact so that the doors close properly and energy consumption is not increased unnecessarily.

OPERATION INSTRUCTIONS

Control panel

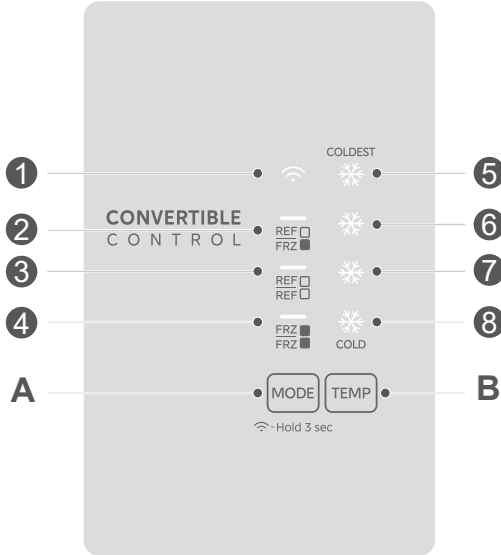

	Display		Button
1	WiFi display icon	A	Mode button
2	Refrigerator/Freeze mode	B	Temperature selection button
3	Refrigerator/Refrigerator mode		
4	Freeze/Freeze mode		
5	Coldest		
6	Colder		
7	Colder		
8	Cold		

ATTENTION

- The actual control panel may differ from model to model.
- The control panel will turn off automatically for energy saving.

MODE button

- > Mode button to switch full freezing mode - > full refrigerated mode - > refrigerated freezing mode

Temperature button

- > Press the temperature adjustment button to adjust the setting gear, COLDEST-> COLD.
- > The four gears in the refrigerated mode are 2 °C, 4 °C, 6 °C, 8 °C.
- > The four gears in the freezing mode are -24 °C, -20 °C, -18 °C, -16 °C.
- > The four gears in the refrigerated/freezing mode are 2/-24 °C, 4/-20 °C, 6/-18 °C, 8/-16 °C.

Network configuration button

- > Press and hold the mode button for 3 seconds to enter the network configuration mode, with wifi light blinking.

Engineering mode

- > Press the mode button and the temperature adjustment button at the same time for 10s, the refrigerator enters the engineering mode, and all LEDs flash; Then press the temperature adjustment button to select the appropriate mode.

Error code

- > The following warnings appearing on the display indicate corresponding faults of the refrigerator. Though the refrigerator may still have cold storage function with the following faults, the user shall contact a maintenance specialist for maintenance, so as to ensure optimized operation of the appliance.

Fault Code	Fault Description
LED7/8 Blinking	Fault of the fridge's temperature sensor
LED6/8 Blinking	Fault of the freezer's defrosting sensor
LED5/8 Blinking	Fault of the environmental temperature
LED5/7 Blinking	Fault of the freezer's temperature sensor

OPEN API

1. Demand response

- Get the current pattern POST /v1/api/plugin/get Demand ResponseInfo.
- Accepts DAL signals POST /v1/api/plugin/demand Response/dal.
- Accepts TALR signals POST /v1/api/plugin/demand Response/ dal.

2. Energy consumption report

- Get the energy statistics report POST /v1/api/plugin/get Energy Statistics Rep.

3. Delay defrosting

- Control switch interface POST /v1/api/plugin/switch Delay Defrost.
- Get the delay interval POST /v1/api/plugin/get Delay DefrostInfo.
- Added delay interval POST /v1/api/plugin/save Delay DefrostInfo.
- Remove the delay interval POST /v1/api/plugin/delete Delay DefrostInfo.

4. Refrigerator self-inspection

- Get refrigerator health status information POST /v1/api/plugin/get Fridge Current Heath.

5. Sabbath mode

- Set the Sabbath mode POST /v1/api/plugin/set Sabbath Mode.

ATTENTION

- The application (SmartHome) interface (about the demand response interface) allows the user to operate according to the smart grid signal intervention mode.

Tips on storing food

Freezer compartment

- > The freezer is designated for the storage of food frozen at very low temperature, long-term storage of frozen food, and for the production of ice.
- > Only use the shelves in the door of the freezer to store frozen food, not for storing hot food designated for freezing.
- > Do not put fresh and frozen food next to each other. The frozen food may thaw.
- > When freezing fresh food (such as meat, fish or chopped meat), cut them into parts that can be used at the same time.
- > Storing frozen food: instructions are usually stated on the packages, which must be followed. If there is no information on the packaging, food should not be stored for longer than three months from the date of purchase.
- > When purchasing frozen food, make sure that it was frozen at a suitable temperature and that the packaging is not damaged.
- > Frozen food should be kept in suitable packages to retain the quality and should be returned to the freezer compartment as soon as possible.
- > If a package of frozen food shows moisture or abnormal bulging, it is probable that it was stored at the wrong temperature and the content is spoiled.
- > The storage period for frozen food depends on the room temperature, the thermostat setting, the frequency of opening the door of the freezer, the type of food and the time of transporting the product from the shop to the household. Always follow the instructions printed on the packaging and never exceed the maximum storage time stated on the package.

Cooling compartment

- > To reduce moisture and subsequent ice build-up, never put liquid into the refrigerator in unsealed containers. Frost tends to concentrate in the coolest parts of the evaporator. Storing uncovered liquids results in a more frequent need for defrosting.
- > Never put warm foods in the refrigerator. These should first cool down at room temperature and then be placed so as to ensure adequate air circulation in the refrigerator.
- > Foods or food containers should not touch the back wall of the refrigerator because they could freeze to the wall. Do not keep regularly opening the door of the refrigerator.
- > Meat and clean fish (packed in a package or plastic foil) can be placed in the refrigerator, which can be used in 1-2 days.
- > Fruit and vegetables without packaging can be placed in the part designated for fresh fruit and vegetables.

Recommended Temperature

The optimal temperature setting for food storage:

- > Fridge: 4 °C , Freezer: -20 °C.

ATTENTION

The optimal temperature setting of each compartment depends on the ambient temperature. Above optimal temperature is based on the ambient temperature of 25 °C.

APP SETUP AND OPERATION

Download the SmartHome App

On an app market (Google Play Store, Apple App Store), search for “SmartHome” and find the SmartHome app. Download and install it on your phone. You can also download the app by scanning the QR code below.



Register and log in

Open the SmartHome app, and create a new account to start (you can also register through a third-party account). If you already have an existing account, use the account to log in.



Connect your devices to SmartHome

1. Please make sure your mobile phone is connected to a wireless network. If it is not, go to Settings and enable wireless networks and Bluetooth.
2. Please power on your devices.
3. Open SmartHome App on your phone.
4. If a message of "Smart devices discovered nearby" appears, click to add.
5. If no message appears, select "+" on the page and select your device in the list of nearby devices available. If your device is not listed, please add your device manually by the device category and device model.
6. Connect your device to the wireless network according to instructions on app. If the connection fails, please follow the instructions provided by the app to continue with the operation.



CLEANING AND MAINTENANCE

Defrosting

- > The refrigerator is made based on the air-cooling principle and thus has automatic defrosting function. Frost formed due to change of season or temperature may also be manually removed by disconnection of the appliance from power supply or by wiping with a dry towel.

Cleaning of door tray

- > According to the direction arrow in the figure below, use both hands to squeeze the tray, and push it upward, then you can take it out.
- > After washing the tray having been taken out, you can adjust its installing height in accordance with your requirement.

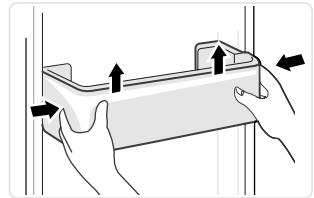

Cleaning of glass shelf

- > As the innermost part of the refrigerator liner where contacting the shelves has a backstop, you shall raise the shelves upward, then you can be able to take it out.
- > Adjust or clean the shelves according to your requirement.

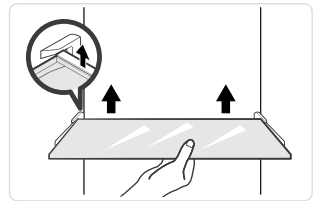

● ATTENTION

Soft towels or sponge dipped in water and non-corrosive neutral detergents are suggested for cleaning. The freezer of shall be finally cleaned with clean water and dry cloth. Open the door for natural drying before the power is turned on. Do not use hard brushes, clean steel balls, wire brushes, abrasives, such as toothpastes, organic solvents (such as alcohol, acetone, banana oil, etc.), boiling water, acid or alkaline items clean refrigerator considering that this may damage the fridge surface and interior.

TROUBLESHOOTING

The following simple issues can be handled by the user. Please call the after-sale service department if the issues are not solved.

Problem	Possible reason
Failed operation	• Check whether the appliance is connected to power or whether the plug is in well contact
	• Check whether the voltage is too low
	• Check whether there is a power failure or partial circuits have tripped
Odor	• Odorous foods shall be tightly wrapped
	• Check whether there is any rotten food
	• Clean the inside of the refrigerator
Long-time operation of the compressor	• Long operation of the refrigerator is normal in summer
	• When the ambient temperature is high it is not suggestible having too much food in the appliance at the same time
	• Food shall get cool before being put into the appliance
	• The doors are opened too frequently
Light fails to get lit	• Check whether the refrigerator is connected to power supply and whether the illuminating light is damaged
	• Have the light replaced by a specialist
Door can not be properly closed	• The door is stuck by food packages Too much food is placed
	• The refrigerator is tilted.
Door seal fails to be tight	• Remove foreign matters on the door seal
	• Heat the door seal and then cool it for restoration (or blow it with an electrical drier or use a hot towel for heating)
Water pan overflows	• There is too much food in the chamber or food stored contains too much water, resulting in heavy defrosting
	• The doors are not closed properly, resulting in frosting due to entry of air and increased water due to defrosting
Hot housing	• Heat dissipation of the built-in condenser via the housing, which is normal When housing becomes hot due to high ambient temperature, storage of too much food or shutdown of the compressor is shut down, provide sound ventilation to facilitate heat dissipation
Surface condensation	• Condensation on the exterior surface and door seals of the refrigerator is normal when the ambient humidity is too high. Just wipe the condensate with a clean towel.

Do you hear these abnormal sounds as below? Usually these sounds are normal.

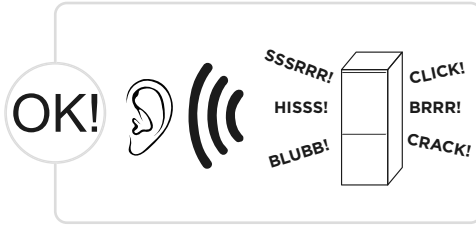

CLICK: Some electrical parts in the refrigerator, such as electric valve will make this noise when working. This is normal.

HISS: When the refrigerant flows into the evaporator, it will make this noise. This is normal.

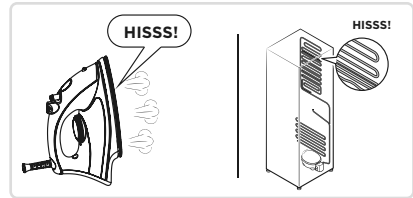
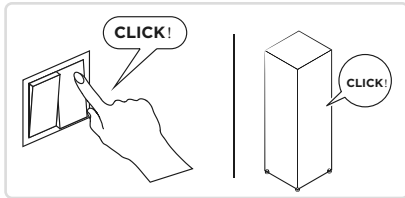

BRRR: The compressor will make this noise when working, and the buzzes are loud particularly upon start or stop. This is normal.

SSSRRR: The fan motor in the No frost refrigerator will make this noise when working. This is normal.

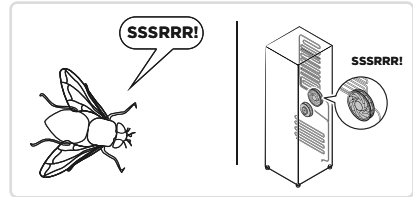
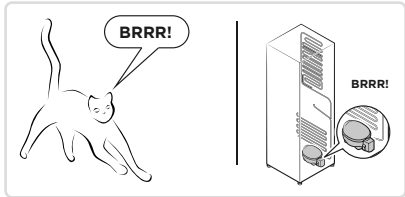

BLUBB: Refrigerant flowing through the pipes in the refrigerator will make this noise. This is normal.

CRACK: Cracking sound or broken ice sound: the overall structure of the refrigerator, air duct frost will be with the thermal expansion and contraction of the expansion sound, these are also normal physical phenomenon.

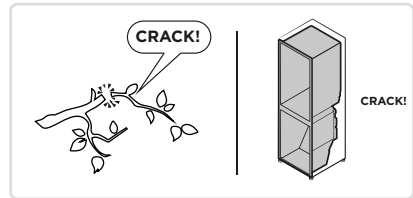
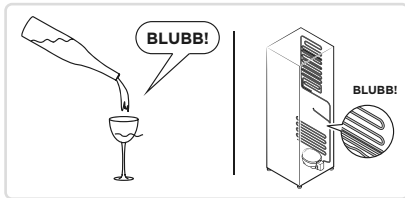

DOC AND CERTIFICATIONS

Federal Communications Commission (FCC) Compliance Statement for USA

This device complies with part 15 of the FCC rules. Operation is subject to the following two conditions: (1) This device may not cause harmful interference, and (2) this device must accept any interference received, including interference that may cause undesired operation.

Note: This equipment has been tested and found to comply with the limits for a Class B digital device, pursuant to part 15 of the FCC Rules. These limits are designed to provide reasonable protection against harmful interference in a residential installation. This equipment generates, uses and can radiate radio frequency energy and, if not installed and used in accordance with the instructions, may cause harmful interference to radio communications. However, there is no guarantee that interference will not occur in a particular installation. If this equipment does cause harmful interference to radio or television reception, which can be determined by turning the equipment off and on, the user is encouraged to try to correct the interference by one or more of the following measures:

- Reorient or relocate the receiving antenna.
- Increase the separation between the equipment and receiver.
- Connect the equipment into an outlet on a circuit different from that to which the receiver is connected.
- Consult the dealer or an experienced radio/TV technician for help.

This equipment complies with FCC radiation exposure limits set forth for an uncontrolled environment.

Industry Canada (IC) Compliance Statement for Canada

This device complies with Industry Canada license-exempt RSS standard(s). Operation is subject to the following two conditions: (1) this device may not cause interference, and (2) this device must accept any interference, including interference that may cause undesired operation of the device.

CAN ICES-003(B)/NMB-003(B)

Midea is not responsible for any changes or modifications not expressly approved by Midea. Such modifications could void the user's authority to operate the equipment.

For model: MWB-S-WB01

FCC ID: 2ADQOMWB-SWB01

IC ID: 12575A-MM3SB3350N3





make yourself at home



www.midea.com

© Midea 2022 all rights reserved