

PORTABLE FRIDGE

USER MANUAL

MDRP27DK3AU(E)

Warning notices: Before using this product, please read this manual carefully and keep it for future reference. The design and specifications are subject to change without prior notice for product improvement. Consult with your dealer or manufacturer for details. The diagram above is just for reference. Please take the appearance of the actual product as the standard.

LANGUAGES

EN

English

THANK YOU LETTER

Thank you for choosing Midea! Before using your new Midea product, please read this manual thoroughly to ensure that you know how to operate the features and functions that your new appliance offers in a safe way.

CONTENTS

THANK YOU LETTER	01
SAFETY INSTRUCTIONS	02
PRODUCT FEATURES	06
SPECIFICATIONS	07
PRODUCT OVERVIEW	08
OPERATION INSTRUCTIONS	10
CLEANING AND MAINTENANCE	12
TROUBLESHOOTING	13
TRADEMARKS, COPYRIGHTS AND LEGAL STATEMENT	14
DISPOSAL AND RECYCLING	15
DATA PROTECTION NOTICE	16

SAFETY INSTRUCTIONS

Intended use

Before switching on the appliance for the first time read the following safety hints!

The device is suitable for cooling food. The device is also suitable for use on vehicles. The device is designed to be operated from a DC power supply socket of a vehicle or from an AC power supply.

The device is also suitable for camping use.

The device is intended to be used in household and similar applications

Such as

- staff kitchen areas in shops, offices and other working environments
- farm houses
- clients in hotels, motels and other residential type environments
- bed and breakfast type environments
- catering and similar non-retail applications

The device is not suitable for:

storage of corrosive, caustic or solvent-containing substances

This device is only suitable for the intended purpose and application in accordance with these instructions.

Explanation of symbols



Danger

This symbol indicates that there are dangers to the life and health of persons due to extremely flammable gas.



Warning of electrical voltage

This symbol indicates that there is a danger to life and health of persons due to voltage.



Warning

The signal word indicates a hazard with a medium level of risk which, if not avoided, may result in death or serious injury.



Caution

The signal word indicates a hazard with a low degree of risk which, if not avoided, may result in minor or moderate injury.



Attention

The signal word indicates important information (e.g. damage to property), but not danger.



Forbidden symbol

This symbol indicates that a service technician should only operate and maintain this appliance in accordance with the operating instructions.

Read these operating instructions carefully and attentively before using/commissioning the unit and keep them in the immediate vicinity of the installation site or unit for later use!

IMPORTANT SAFETY INSTRUCTIONS



WARNING

To reduce the risk of fire, electrical shock, or injury when using your appliance, follow these basic precautions:

- **Before using the appliance, please read this user manual to ensure that you gain the maximum benefit from it.**

WARNING

1. This appliance is not intended for use by persons (including children) with reduced physical, sensory or mental capabilities, or lack of experience and knowledge, unless they have been given supervision or instruction concerning use of the appliance by a person responsible for their safety.
2. Children should be supervised to ensure that they do not play with the appliance.
3. This appliance can be used by children aged from 8 years and above and persons with reduced physical, sensory or mental capabilities or lack of experience and knowledge if they have been given supervision or instruction concerning use of the appliance in a safe way and understand the hazards involved. Children shall not play with the appliance. Cleaning and user maintenance shall not be made by children without supervision.
4. If the supply cord is damaged, it must be replaced by the manufacturer, its service agent or similarly qualified persons in order to avoid a hazard.
5. To avoid a hazard due to instability of the appliance, it must be fixed in accordance with the instructions.
6. When positioning the appliance, ensure the supply cord is not trapped or damaged.
7. Do not locate multiple portable socket-outlets or portable power supplies at the rear of the appliance.
8. **WARNING:** Keep ventilation openings, in the appliance enclosure or in the built-in structure, clear of obstruction.
9. **WARNING:** Do not use mechanical devices or other means to accelerate the defrosting process, other than those recommended by the manufacturer.
10. **WARNING:** Do not damage the refrigerant circuit.
11. **WARNING:** Do not use electrical appliances inside the drink storage compartments of the appliance, unless they are of the type recommended by the manufacturer.
12. Do not store explosive substances such as aerosol cans with a flammable propellant in this appliance.
13. To avoid contamination of drink, please respect the following instructions:
 - Opening the door for long periods can cause a significant increase of the temperature in the compartments of the appliance.
 - Clean regularly surfaces that can come in contact with drink and accessible drainage systems.
 - If the refrigerating appliance is left empty for long periods, switch off, defrost, clean, dry, and leave the door open to prevent mould developing within the appliance.
14. The appliance shall not be exposed to rain.

-Save these instructions-



WARNING

Risk of fire/Flammable material

This symbol alerts you to flammable materials that can ignite and cause a fire if you do not take care.

- Refrigerant and cyclopentane foaming material used for the appliance are flammable. Therefore, when the appliance is scrapped, it shall be kept away from any fire source and be recovered by a special recovering company with corresponding qualification other than be disposed by combustion, so as to prevent damage to the environment or any other harm.



CAUTION

When this appliance is used to AC power, please use the adapter to connect the AC power supply.

When this appliance is used to DC power, please connect the vehicle power DC 12V or DC24V.



WARNING Electrical safety



FORBID

When unplugging the device, hold the plug firmly and pull it out of the socket. Do not pull the power cord. Do not touch the power plug of the device with wet hands or feet in contact with water! In order to ensure safe use, do not damage the power cord at any time. If the power cord is damaged, it must be replaced by the manufacturer, its maintenance department or similar professionals to avoid danger.



WARNING

When the product is used in the car, if the product is connected to the main power supply, it must be ensured that the power supply has a fuse. To ensure that the power supply voltage connected to the product is correct at all times, the parameters at the bottom of the product are labeled with the product approved voltage parameters.



ATTENTION

Do not place or use electrical products inside the device container.

This appliance contains flammable foaming agent cyclopentane.

Please avoid contact fire when you transport and use it.

Please ask professional for servicing when the machine broke down.

Please send it to your local appointed disposal station when you discard it.

Safety Precautions

- When the product is used in a car, if the product is connected to the main power supply, it must be ensured that the power supply has a fuse.
- To ensure that the product is connected to the correct power supply voltage at all times, the product voltage parameter is on the parameter label at the bottom of the product.
- When the set temperature is less than or equal to 0°C, do not place glass containers to avoid cracking.
- After unpacking the device, let it stand for more than 24 hours before powering on.
- Ensure that the device is placed horizontally during operation, and the inclination angle is less than 5° for long-term operation.
- When water accumulates in the inner tank, do not turn the device upside down to pour water, just use the drain hole to drain.
- Appliances that use combustible thermal insulation foaming gas: The refrigerant and cyclopentane foaming materials used in this device are both combustible materials. The waste device should be isolated from the fire source and cannot be burned. Please send it to a qualified professional recycling company for disposal. To avoid harm to the environment or cause other dangers.







PRODUCT FEATURES

Product features

Adopting high-efficiency and energy-saving DC compressor and conversion module, high reliability, long service life, fast device cooling speed.

1. Adopt fluorine-free insulation layer, good insulation performance, low energy consumption.
2. Dual purpose for car and home, use car DC12/24V or home AC 100-240V power supply (adapter is required).
3. Rapid ultra-low cooling to -20°C.
4. Single temperature zone single control.
5. Intelligent protection system for car battery.
6. Intelligent energy saving system.

Recommended storage temperature for commonly used items

Type	Red wine	Insulin	Fruit	Beverage	Meat	Ice cream
graphical representation						
Recommended temperature	10°C	2°C-8°C	4°C-6°C	2°C-5°C	-10°C	-15°C

SPECIFICATIONS

Product model	MDRP27DK3AU(E)
Dimension(mm)	600x337x388
Capacity(L)	27
Net Weight(kg)	13.1
Gross Weight(kg)	14.5
Rated voltage(V)	DC 12/24V, AC 100-240V
Frequency(Hz)	50/60Hz
Rated Current For AC(Adaptor)	DC 6/3A, AC 2.5A
Refrigerant	R1234YF(26g)
Foaming Gas	cyclopentane
Protective Classification of Electric Shock Resistance	
Refrigeration performance	32°C ambient temperature, cooling temperature range in side: Large compartment temperature-20°C-+20°C

Parts List

1. User Manual
2. DC Adapter
3. AC Adapter
4. Warranty card
5. Energy label

PRODUCT OVERVIEW

Names of components

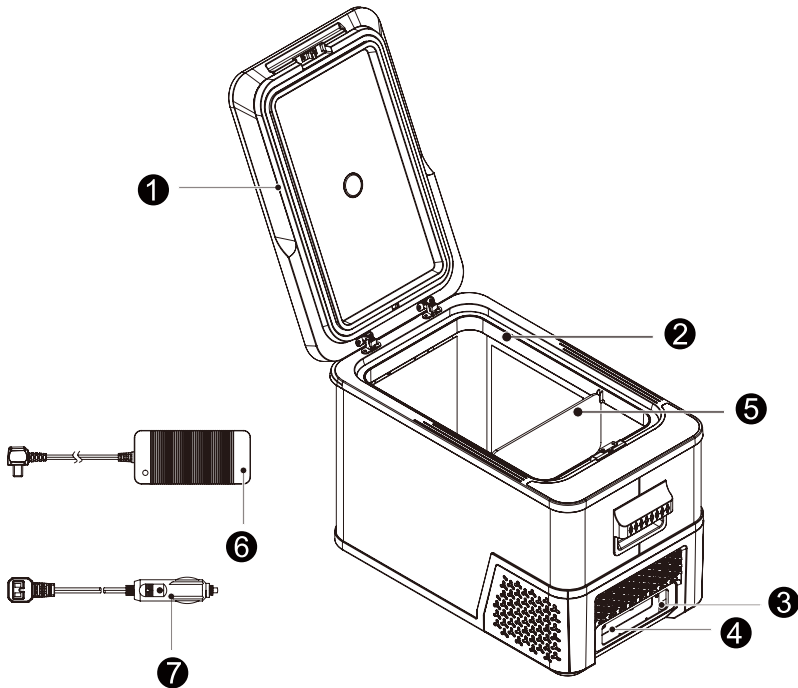

- 1 Refrigerator door
- 3 Fuse
- 5 Diaphragm
- 7 DC Adapter

- 2 Refrigerator
- 4 Power plug
- 6 AC Adapter

● ATTENTION

The picture above is only for reference. The actual configuration will depend on the physical product or statement by the distributor

Fuse installation and replacement instructions

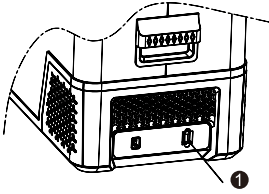

1. Locate the fuse protection cover shown in the figure ①, and carry out Shake left and right to remove the cover.

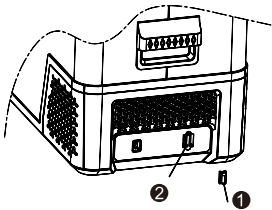

2. After removing the parts ①, set aside and use needle-nose pliers to clamp. Then pull out the fuse shown in ②.

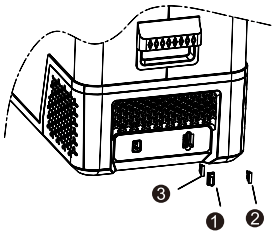

3. Check whether the fuse is damaged, such as blown fuse need to replace a new fuse.

Specification: current 15A Automotive grade fuses.

If the fuse needs to be replaced. The fuse ③ is inserted into the fuse holder, and then ① the fuse is protected it can be installed after the outer cover is in place.

OPERATION INSTRUCTIONS

Control panel operation

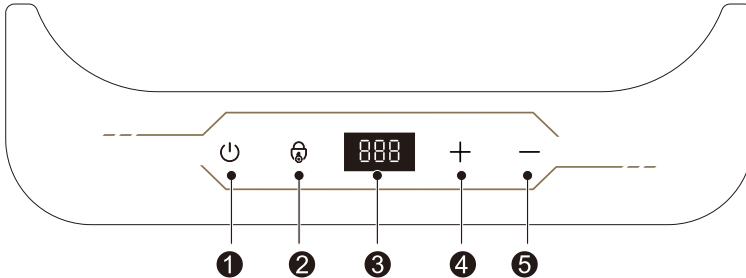

- | | | | |
|---|---------------------|---|------------------|
| 1 | Power switch | 2 | Unlock button |
| 3 | Temperature display | 4 | Temperature plus |
| 5 | Temperature minus | | |

Power switch:

In the unlocked state, press and hold it for 2 seconds to shut down; when in the shut down state, press and hold it for 2 seconds and then turn it on.

Unlock button:

This button is an anti-misoperation function key, after power on, the device's all buttons turn to breathing display mode, then all keys can be operated during this time, if there is no operation within 20 seconds, the device will automatically turn on the anti-misoperation function (or press and hold the unlock button for 2 seconds and then manually turn on the anti-misoperation function), all the keys are locked after turning it on, press the unlock button for 2 seconds to unlock the device control system and enter the adjustable mode.

Temperature plus/minus key:

temperature control, adjustable temperature range is -20 ~ 20°C.

Fahrenheit and Celsius temperature display switch:

In the locked state, press the temperature plus and minus buttons at the same time for 3 seconds to switch between Fahrenheit and Celsius.

Battery voltage protection setting:

In the keys unlock state, press and hold the unlock button and the switch key at the same time for more than 2 seconds to enter the battery voltage protection regulation system, select the voltage protection H1/H2/H3, the default voltage protection is H2; enter the mode then press and hold the unlock button and the switch button at the same time for more than 2 seconds to adjust the protection. For detailed voltage protection parameters, see Appendix 1.

ATTENTION

This is the car battery voltage protection function; it is set to protect the car battery power under the normal operation of the device, and prevent the car battery from being consumed too much and the vehicle cannot be started; the output voltage of different vehicle power sources is different, if the voltage protection value "E1" appears on the display, please manually adjust the voltage protection according to the actual situation of the vehicle.

Restore the factory default

In the shutdown state, press and hold the plus and minus keys of the large compartment at the same time for more than 3 seconds to restore the default values of the parameters.

Mode	12V stop value	12V start value	24V stop value	24V start value
H1	9.6V	10.9V	21.3V	22.7V
H2	10.1V	11.4V	22.3V	22.7V
H3	11.1V	12.4V	24.3V	25.7V

ATTENTION

Due to the voltage drop during product operation, the actual value will have a deviation of $\pm 0.3V$

CLEANING AND MAINTENANCE

Daily Cleaning

Cleaning method

Every other week, clean and maintain the device once, wipe the inside and outside surfaces of the device with a warm damp rag. If it is too dirty, use neutral detergent to wipe and then wipe the water stain with a clean wet cloth.

Maintenance of plastic parts

Properly protect the door seal, must often keep clean, try to avoid oil stains and deformation, if the oil (animal or vegetable oil) attached to the plastic in the box for a long time, the plastic is easy to age or crack, and smell, so to develop a habit of frequent cleaning.

Precautions

It is strictly prohibited to wash the device directly with water to prevent the insulation of electrical appliances from being reduced and metal parts from rusting. Do not use: alkaline detergent, soap, grinding powder, hot water, brush, water, gasoline, alcohol to clean the device, otherwise it will damage the paint layer, plastic parts.

Stop Using

Power failure:

Foods can be preserved for a couple of hours even in summer in case of power failure; it is recommended to reduce the frequency of opening door and do not put fresh foods into the car device.

Long-time nonuse:

Please unplug the car device if it is left unused for a long time for cleaning. Keep the door open to avoid the bad odor.

Moving:

When it needs to move the device, do not turn upside or vibrate the car refrigerator, the carrying angle can not be greater than 45°.

TROUBLESHOOTING

The following simple issues can be handled by the user. Please call the after-sale service department if the issues are not settled.

The device does not work

- Check whether there is a power supply or the voltage is correct;
- Check whether the power plug is in good contact;
- Whether the fuse is blown;
- Check whether the power switch on the display operation panel is turned on;
- The compressor is under protection after 3 minutes of startup;

The food in the device is frozen

- The temperature setting is too low, increase the temperature appropriately.

Hear the sound of running water in the box

- The sound of refrigerant flowing is normal.

Display error code and processing method

- When the compressor control module displays the fault code, the device will not work until the fault is eliminated. The specific fault code corresponding to the troubleshooting method is described in Appendix.

Failure code	Failure description	Remarks
E1	Voltage failure	Low voltage protection code, lower the battery protection switch one level, H3 (high)-H2 (middle) -H1 (low) (see attached table 1 for details).
E2	Fan current failure	Fan overload protection, shut down and rest for 30 minutes and then turn on again
E3	Compressor start failure	Compressor frequent start protection, shut down and reopen after 30 minutes
E4	Compressor minimum speed failure	If the compressor load is too large or the motor speed is too low, shut it down and let it stand for 30 minutes before restarting.
E5	Controller temperature failure	The temperature of the controller shell is too high (greater than 85°C), put the device in a lowtemperature ventilated place, shut it down and let it stand for 30 minutes and then turn it on again; if it happens again, please contact aftersales persons
E6	Controller hardware failure	The controller cannot detect normal parameters, shut down and restart, if it reappears again, send back to detect
EE	Short circuit of temperature sensor	The temperature sensor is abnormal, and it is cooled in the default working mode. It will stop for 30 minutes and stop for 15 minutes without temperature control function. Check whether the temperature sensor terminal is off, if it appears again, please contact after-sales persons

TRADEMARKS, COPYRIGHTS AND LEGAL STATEMENT

 Midea logo, word marks, trade name, trade dress and all versions thereof are valuable assets of Midea Group and/or its affiliates (“Midea”), to which Midea owns trademarks, copyrights and other intellectual property rights, and all goodwill derived from using any part of an Midea trademark. Use of Midea trademark for commercial purposes without the prior written consent of Midea may constitute trademark infringement or unfair competition in violation of relevant laws.

This manual is created by Midea and Midea reserves all copyrights thereof. No entity or individual may use, duplicate, modify, distribute in whole or in part this manual, or bundle or sell with other products without the prior written consent of Midea.

All the described functions and instructions were up to date at the time of printing this manual. However, the actual product may vary due to improved functions and designs.

DISPOSAL AND RECYCLING

Important instructions for environment

Compliance with the WEEE Directive and Disposing of the Waster Product: This product bears a classification symbol for waster electrical and electronic equipment (WEEE).

This symbol indicates that this product shall not be disposed with other household wastes at the end of its service life. Used device must be returned to official collection point for recycling of electrical electronic devices. To find these collection systems please contact to your local authorities or retailer where the product was purchased. Each household performs important role in recovering and recycling of old appliance. Appropriate disposal of used appliance helps prevent potential negative consequences for the environment and human health.



Package information

Packaging materials of the product are manufactured from recyclable materials in accordance with our National Environment Regulations. Do not dispose of the packaging materials together with the domestic or other wastes. Take them to the packaging material collection points designated by the local authorities.



DATA PROTECTION NOTICE

For the provision of the services agreed with the customer, we agree to comply without restriction with all stipulations of applicable data protection law, in line with agreed countries within which services to the customer will be delivered, as well as, where applicable, the EU General Data Protection Regulation (GDPR).

Generally, our data processing is to fulfil our obligation under contract with you and for product safety reasons, to safeguard your rights in connection with warranty and product registration questions. In some cases, but only if appropriate data protection is ensured, personal data might be transferred to recipients located outside of the European Economic Area.

Further information are provided on request. You can contact our Data Protection Officer via **MideaDPO@midea.com**. To exercise your rights such as right to object your personal data being processed for direct marketing purposes, please contact us via **MideaDPO@midea.com**. To find further information, please follow the QR Code.