



R410A

Commercial Air Conditioners

Technical Service Manual

Quantum Series (AU)



Model:

UCMI200OC-3PH

UCMI220OC-3PH

DUCMI200IHC-3PH

DUCMI220IHC-3PH

CONTENTS

| | |
|--|------------|
| Part 1 General Information | 3 |
| Part 2 Outdoor Unit Engineering Date..... | 5 |
| Part 3 Indoor Unit Engineering Date..... | 17 |
| Part 4 System Design and Installation | 27 |
| Part 5 Electrical Components and Wiring Diagrams..... | 47 |
| Part 6 Outdoor Unit Diagnosis and Troubleshooting | 61 |
| Part 7 Indoor Unit Diagnosis and Troubleshooting | 119 |

Part 1

General Information

1 External Appearance 4

1 External Appearance

1.1 Indoor Units

Table 1-2.1: Indoor unit appearance

DUCMI200IHC-3PH / DUCMI220IHC-3PH



1.2 Outdoor Units

Table 1-2.2: Outdoor unit appearance

UCMI200OC-3PH / UCMI220OC-3PH



Note: One outdoor unit can only be connected to one indoor unit, and the capacity of the indoor and outdoor units must be the same.

Part 2

Outdoor Unit

Engineering Data

| | |
|---|----|
| 1 Specifications | 6 |
| 2 Dimensions | 7 |
| 3 Installation Space Requirements | 8 |
| 4 Piping Diagrams | 9 |
| 5 Wiring Diagrams..... | 11 |
| 6 Electrical Characteristics..... | 12 |
| 7 Operating Limits..... | 13 |
| 8 Sound Levels | 14 |
| 9 Accessories | 15 |

1 Specifications

Table 2-1.1: Outdoor unit specifications

| Model Name | Outdoor Unit | | UCMI200OC-3PH | UCMI220OC-3PH |
|----------------------------------|---|-------------------|--------------------|---------------|
| Power supply | Outdoor Unit | V/Ph/Hz | 380-415/3/50 | |
| Power input | Outdoor unit + indoor unit | | 6.7 | 6.99 |
| Cooling ¹ | Capacity | kW | 20.5 | 22.0 |
| | | kBtu/h | 69.9 | 75.0 |
| | EER | | 3.06 | 3.15 |
| | AEER | | 3.08 | 3.15 |
| Heating ² | Capacity | kW | 23.0 | 24.5 |
| | | kBtu/h | 78.4 | 83.6 |
| | COP | | 3.29 | 3.40 |
| | ACOP | | 3.28 | 3.25 |
| Star rating | HOT: Brisbane Darwin Pacific Is | Cooling | 2 | 2 |
| | | Heating | 2 | 2 |
| | AVERAGE: Adelaide, Perth, Sydney | Cooling | 1.5 | 1.5 |
| | | Heating | 1.5 | 1.5 |
| | COLD: Canberra, Hobart, Melbourne, New Zealand | Cooling | 1.5 | 2 |
| | | Heating | 1.5 | 1.5 |
| Ambient temp. operation range | Cooling | °C (DB) | -5~48 | |
| | Heating | °C (WB) | -20~24 | |
| Outdoor Unit | Compressor type | | DC inverter rotary | |
| | Compressor quantity | | 1 | |
| | Fan type | | Propeller | |
| | Fan quantity | | 2 | |
| | Air flow rate | m ³ /h | 11300 | |
| | Refrigerant type | | R410A | |
| | Refrigerant factory charge | | 10.2 | |
| | Sound pressure level ³ | dB(A) | 61 | |
| | Sound power level | dB(A) | 81 | |
| | Net dimensions (W×H×D) | mm | 1120×1558×528 | |
| | Packed dimensions (W×H×D) | mm | 1270×1720×565 | |
| | Net weight | kg | 159 | |
| Gross weight | kg | 175 | | |
| Max pipe length/height | | m | 60/40 | |
| Pipe connections | Liquid pipe | mm | 12.7 | |
| | Gas pipe | mm | 25.4 | |

Notes:

- Indoor temperature 27°C DB, 19°C WB; outdoor temperature 35°C DB; equivalent refrigerant piping length 7.5m with zero level difference.
- Indoor temperature 20°C DB; outdoor temperature 7°C DB, 6°C WB; equivalent refrigerant piping length 7.5m with zero level difference.
- Sound pressure level is measured at a position 1m in front of the unit and 1m above the floor in a semi-anechoic chamber.

2 Dimensions

Figure 2-2.1: Dimensions (unit: mm)

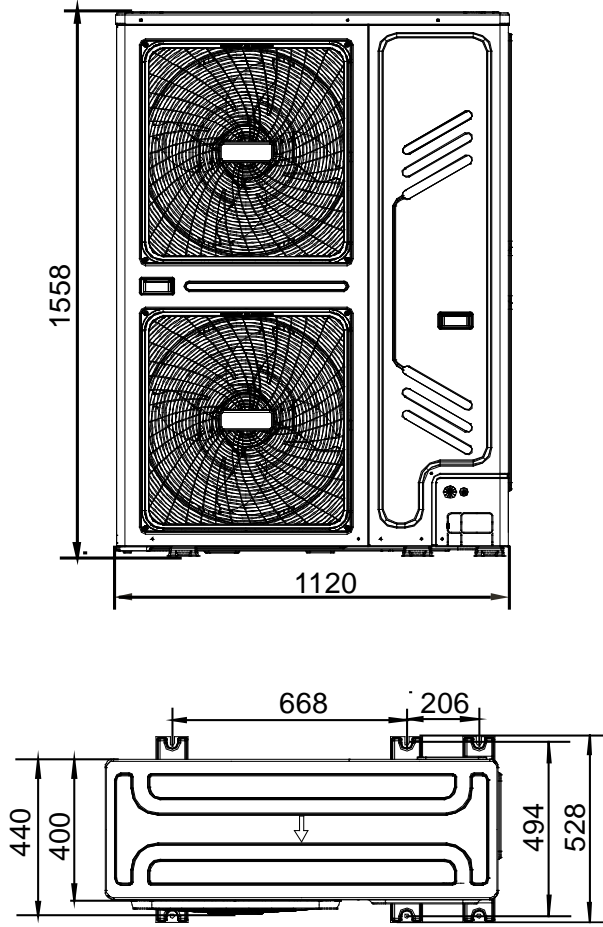

3 Installation Space Requirements

For single unit installation

Figure 2-3.1: Single unit installation (unit: mm)

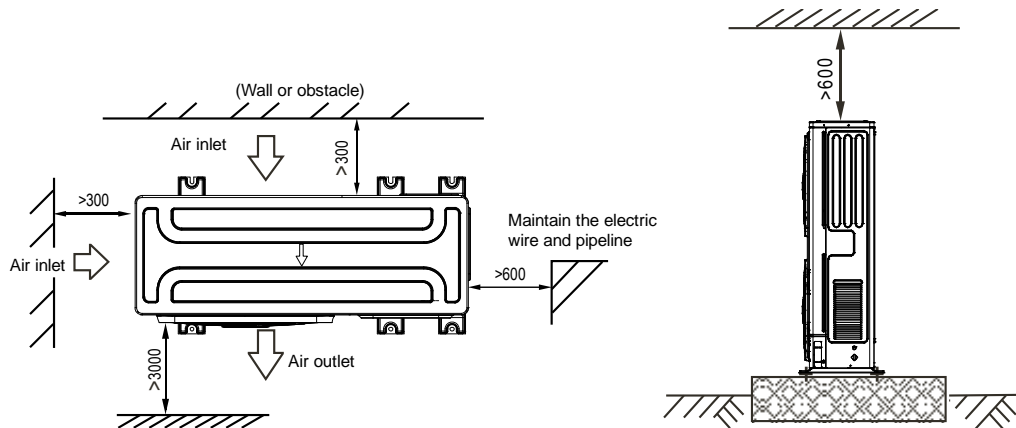

For single-row installation

Figure 2-3.2: Two units or above installation (unit: mm)

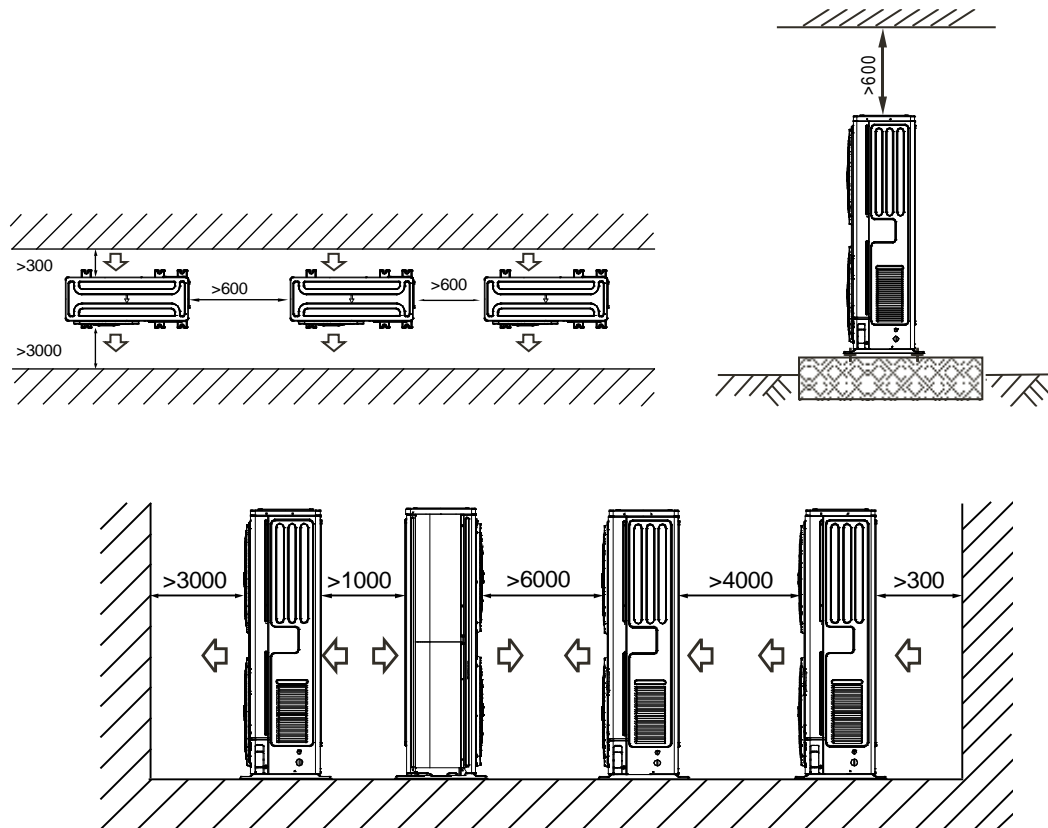

4 Piping Diagrams

Figure 2-4.1: Piping diagram

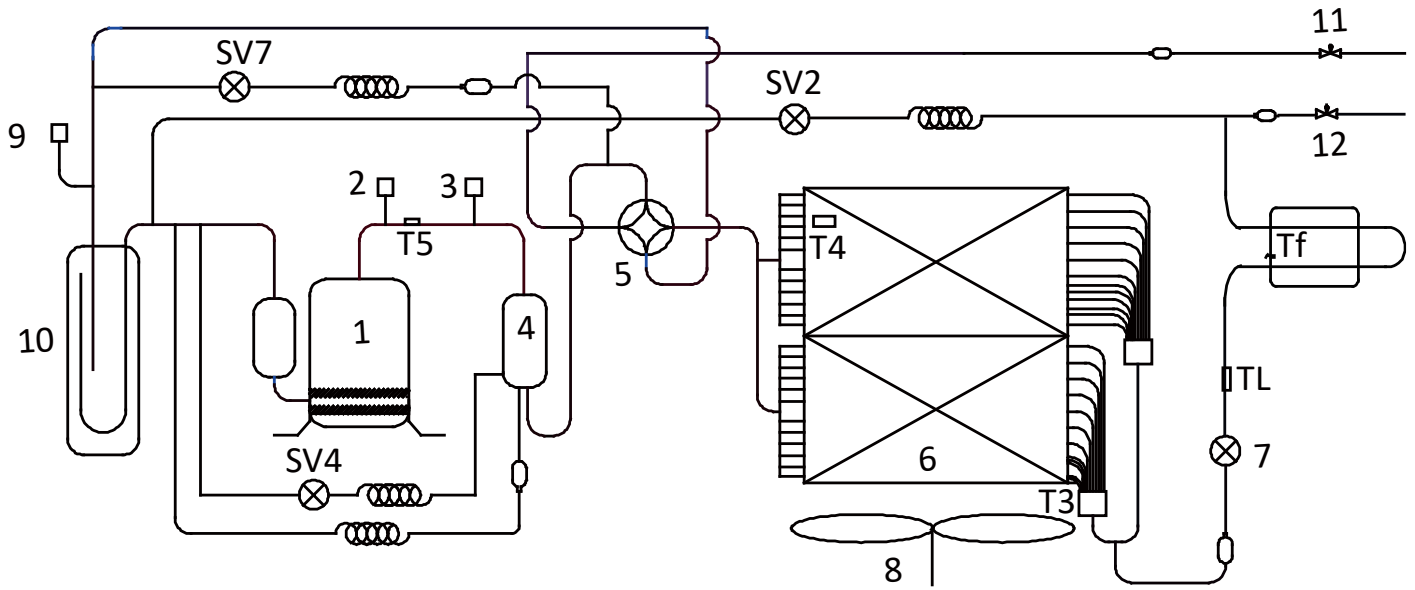

| Legend | | | |
|--------|----------------------------------|-----|---|
| No. | Parts name | No. | Parts name |
| 1 | Compressor | 11 | Stop valve (gas side) |
| 2 | High pressure switch | 12 | Stop valve (liquid side) |
| 3 | High pressure sensor | T3 | Heat exchanger temperature sensor |
| 4 | Oil separator | T4 | Outdoor ambient temperature sensor |
| 5 | Four-way valve | T5 | Discharge temperature sensor |
| 6 | Heat exchanger | Tf | Heat sink temperature sensor |
| 7 | Electronic expansion valve (EXV) | TL | Refrigerant cooling pipe temperature sensor |
| 8 | Fan | SV2 | Liquid injection valve |
| 9 | Low pressure switch | SV4 | Oil return valve |
| 10 | Accumulator | SV7 | Refrigerant bypass valve |

Key components:

- 1. Oil separator:**

Separates oil from gas refrigerant pumped out of the compressor and quickly returns it to the compressor. Separation efficiency is up to 99%.
- 2. Accumulator:**

Stores liquid refrigerant and oil to protect compressor from liquid hammering.
- 3. Electronic expansion valve (EXV):**

Controls refrigerant flow and reduces refrigerant pressure.
- 4. Four-way valve:**

Controls refrigerant flow direction. Closed in cooling mode and open in heating mode. When closed, the heat exchanger functions as a condenser; when open, the heat exchanger functions as an evaporator.
- 5. Solenoid valve SV2:**

Protects the compressor. If compressor discharge temperature rises above 98°C, SV2 opens and sprays a small amount of liquid refrigerant to cool the compressor. SV2 closes again once the discharge temperature has fallen below 85°C.
- 6. Solenoid valve SV4:**

Returns oil to the compressor. Opens once the compressor has run for 200 seconds and closes 600 seconds later and then opens for 3 minutes every 20 minutes.
- 7. Solenoid valve SV7:**

Allows refrigerant return to the compressor directly. Opens when indoor air temperature is close to the set temperature to avoid frequent compressor on/off.
- 8. High and low pressure switches:**

Regulate system pressure. When system pressure rises above the upper limit or falls below the lower limit, the high or low pressure switches turn off, stopping the compressor. After 5 minutes, the compressor restarts.

5 Wiring Diagrams

Figure 2-5.1: Wiring diagram

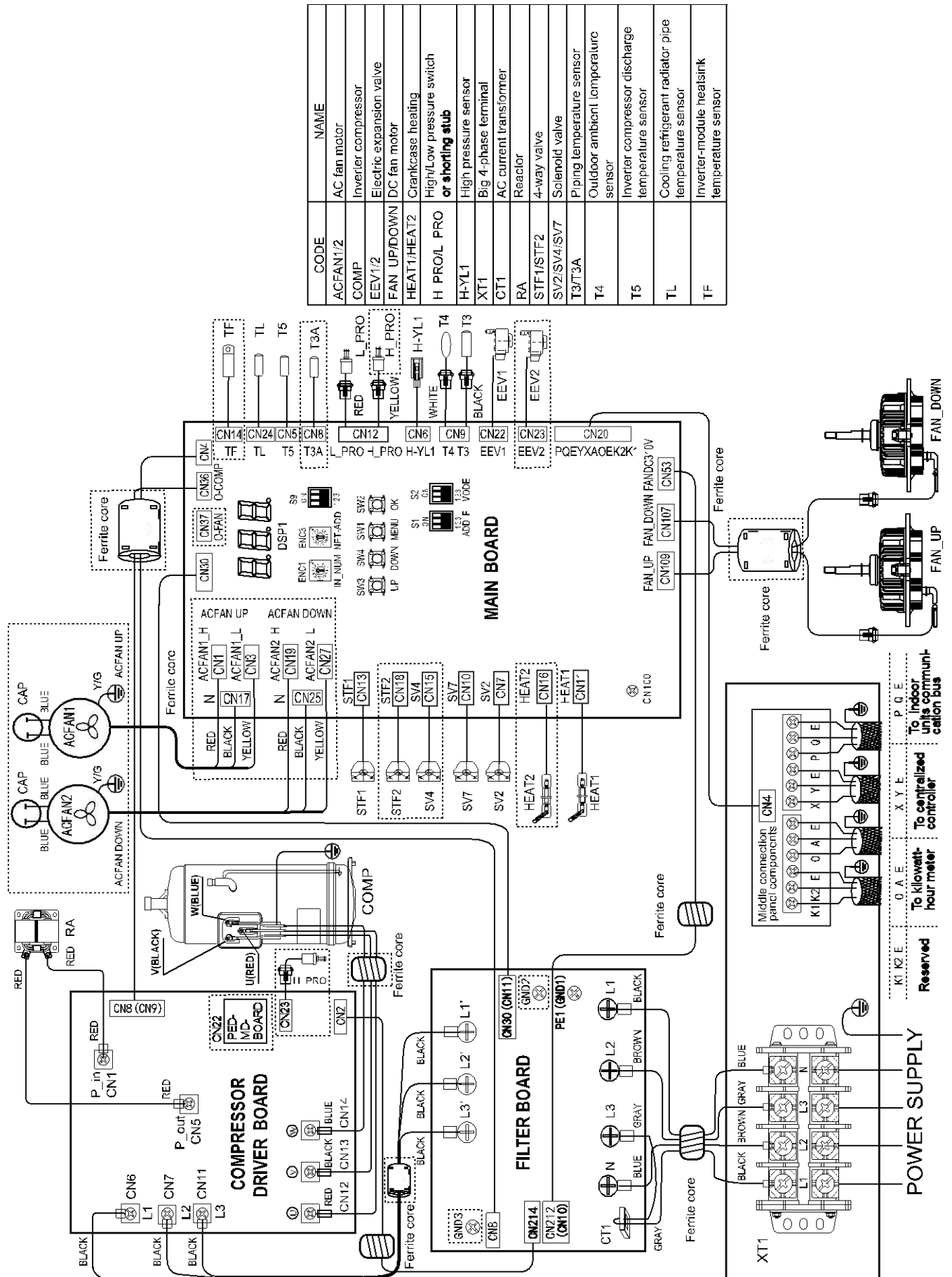

6 Electrical Characteristics

Table 2-6.1: Outdoor unit electrical characteristics

| Model | Power Supply ¹ | | | | | | Compressor | | OFM | | |
|---------------|---------------------------|---------|-------|-------|------------------|-------------------|------------------|------------------|------------------|--------|---------|
| | Hz | Volts | Min. | Max. | MCA ² | TOCA ³ | MFA ⁴ | MSC ⁵ | RLA ⁶ | kW | FLA |
| | | | volts | volts | | | | | | | |
| UCMI200OC-3PH | 50 | 380~415 | 342 | 456 | 26.4 | 33.2 | 32 | / | 19.6 | 2×0.17 | 2.1+2.1 |
| UCMI220OC-3PH | 50 | 380~415 | 342 | 456 | 26.4 | 33.2 | 32 | / | 19.6 | 2×0.17 | 2.1+2.1 |

Abbreviations:

MCA: Minimum Circuit Amps; TOCA: Total Over-current Amps; MFA: Maximum Fuse Amps; MSC: Maximum Starting Current (A); RLA: Rated Load Amps; FLA: Full Load Amps

Notes:

1. Units are suitable for use on electrical systems where voltage supplied to unit terminals is not below or above listed range limits. Maximum allowable voltage variation between phases is 2%.
2. Select wire size based on the value of MCA.
3. TOCA indicates the total overcurrent amps value of each OC set.
4. MFA is used to select overcurrent circuit breakers and residual-current circuit breakers.
5. MSC indicates the maximum current on compressor start-up in amps.
6. RLA is based on the following conditions: indoor temperature 27°C DB, 19°C WB; outdoor temperature 35°C DB.

7 Operating Limits

Figure 2-7.1: Cooling operating limits

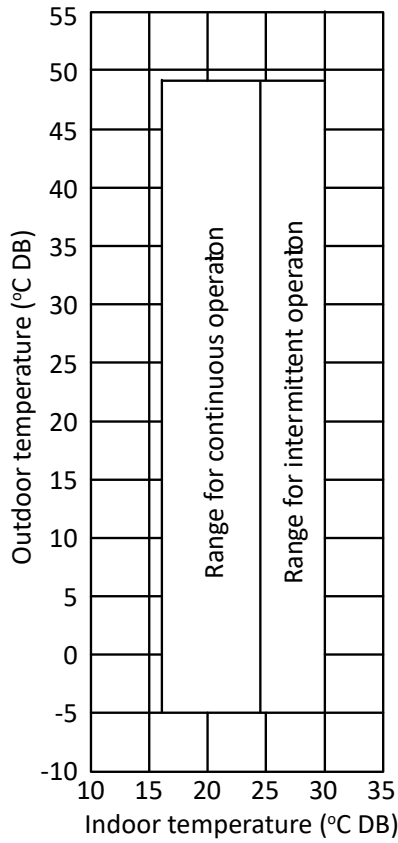
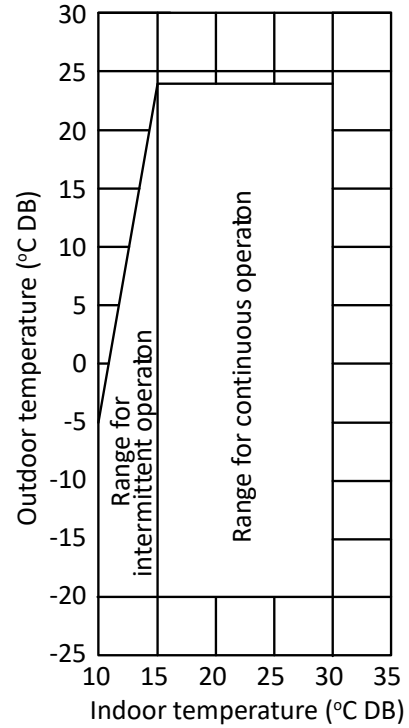

Figure 2-7.2: Heating operating limits



Notes:

- These figures assume the following operating conditions:
 - Equivalent piping length: 7.5m
 - Level difference: 0

8 Sound Levels

8.1 Overall

Table 2-8.1: Sound pressure level

| Model | dB(A) |
|---------------|-------|
| UCMI200OC-3PH | 61 |
| UCMI220OC-3PH | 61 |

- Notes:
1. Sound pressure level is measured at a position 1m in front of the unit and 1m above the floor in a semi-anechoic chamber. During in-situ operation, sound pressure levels may be higher as a result of ambient noise.

Figure 2-8.1: Sound pressure level measurement (unit: m)

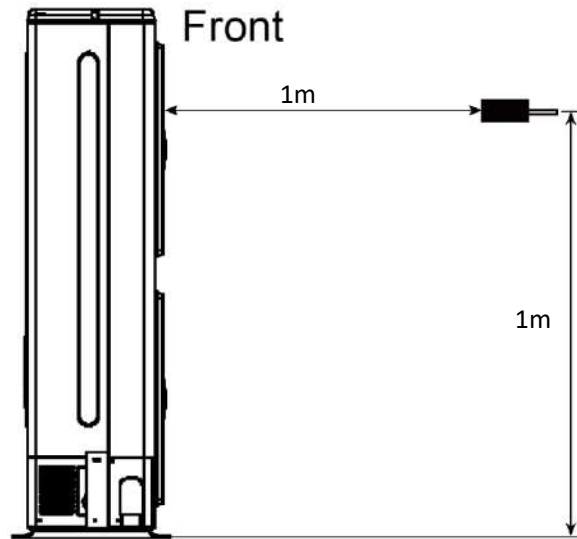

8.2 Octave Band Levels

Figure 2-8.2: UCMI200OC-3PH octave band level

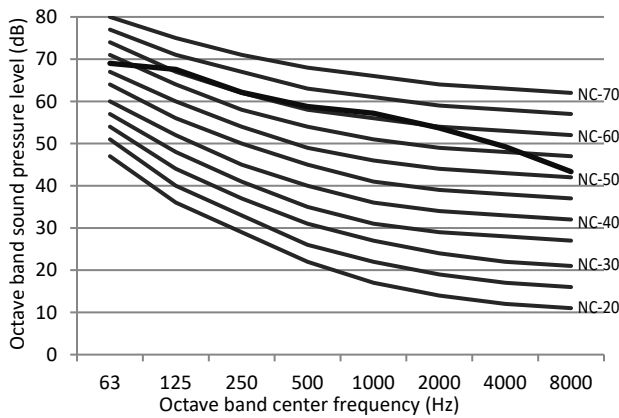
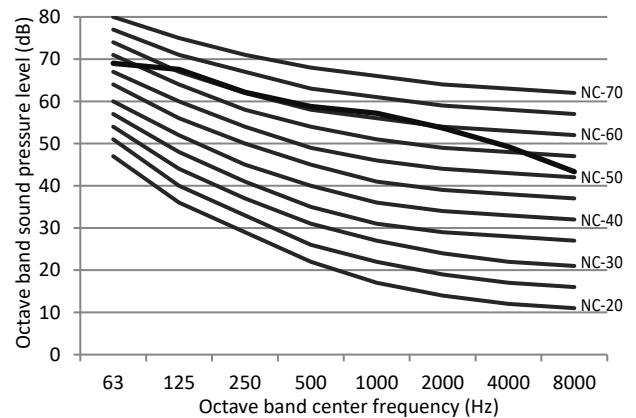







Figure 2-8.3: UCMI220OC-3PH octave band level



9 Accessories

Table 2-9.1: Standard accessories

| Name | Shape | Quantity | Function |
|---|---|----------|----------------------------------|
| Outdoor unit installation manual |  | 1 | |
| Outdoor unit owner's manual | | 1 | |
| Installation instructions: Indoor unit manifold | | 1 | |
| Water outlet connection pipe |  | 1 | Used for outdoor drainage |
| Matched resistor |  | 2 | Enhances communication stability |
| Waterproof chassis cover |  | 2 | Used for centralized drainage |
| Connection pipe |  | 1 | Connecting pipes |

Part 3

Indoor Unit

Engineering Data

| | |
|-----------------------------------|----|
| 1 Specifications | 18 |
| 2 Dimensions | 19 |
| 3 Unit Placement | 20 |
| 4 Piping Diagram | 21 |
| 5 Wiring Diagram | 22 |
| 6 Electrical Characteristics..... | 24 |
| 7 Sound Levels | 25 |
| 8 Fan Performance | 26 |

1 Specifications

Table 3-1.1: Indoor unit specifications

| Model Name | Indoor Unit | | DUCMI200IHC-3PH | DUCMI220IHC-3PH |
|--|---------------------------------------|-------------------|------------------------------------|-----------------|
| Power supply | Indoor Unit | V/Ph/Hz | 220-240V/1/50-60Hz | |
| Power input (outdoor unit + indoor unit) | | kW | 6.7 | 6.99 |
| Cooling ¹ | Capacity | kW | 20.5 | 22.0 |
| | | kBtu/h | 69.9 | 75.0 |
| | EER | | 3.06 | 3.15 |
| | AEER | | 3.10 | 3.10 |
| Heating ² | Capacity | kW | 23.0 | 24.5 |
| | | kBtu/h | 78.4 | 83.6 |
| | COP | | 3.29 | 3.40 |
| | ACOP | | 3.25 | 3.25 |
| Indoor unit | Air flow rate ³ | m ³ /h | 5200/4911/4622/4333/4044/3756/3467 | |
| | External static pressure ⁴ | Pa | 150 (50-280) | |
| | Sound pressure level ⁵ | dB(A) | 51/49/47/45/43.5/42/41 | |
| | Sound power level | dB(A) | 70.5/69/67/65/63/61/60 | |
| | Net dimensions (W×H×D) ⁶ | mm | 1300×477×910 | |
| | Packed dimensions (W×H×D) | mm | 1580×650×1090 | |
| | Net weight | kg | 82 | |
| | Gross weight | kg | 120 | |
| Max pipe length/height | | m | 60/40 | |
| Pipe connections | Liquid pipe | mm | 12.7 | |
| | Gas pipe | mm | 25.4 | |
| | Drain pipe | mm | OD Φ32 | |

Notes:

- Indoor temperature 27°C DB, 19°C WB; outdoor temperature 35°C DB; equivalent refrigerant piping length 7.5m with zero level difference.
- Indoor temperature 20°C DB; outdoor temperature 7°C DB, 6°C WB; equivalent refrigerant piping length 7.5m with zero level difference.
- Fan motor speed and air flow rate are from the highest speed to the lowest speed, total 7 rates for each model.
- Stable operation external static pressure range. (Setting external static pressure outside the unit's optimal static pressure range may lead to higher noise levels and lower airflow rate. For the optimal external static pressure range refer to the unit's installation manual.)
- Sound pressure level is from highest level to lowest level, total 7 levels for each model. Sound pressure level is measured 1.4m below the unit in a semi-anechoic chamber.
- Unit body dimensions given are the largest external dimensions of the unit, no including hanger attachments.

2 Dimensions

2.1 Unit Dimensions

Figure 2.1: High Static Pressure Duct dimensions (unit: mm)

Appearance and dimensions of the air inlets, piping, drain pipes, power cable hole and communication wire hole:

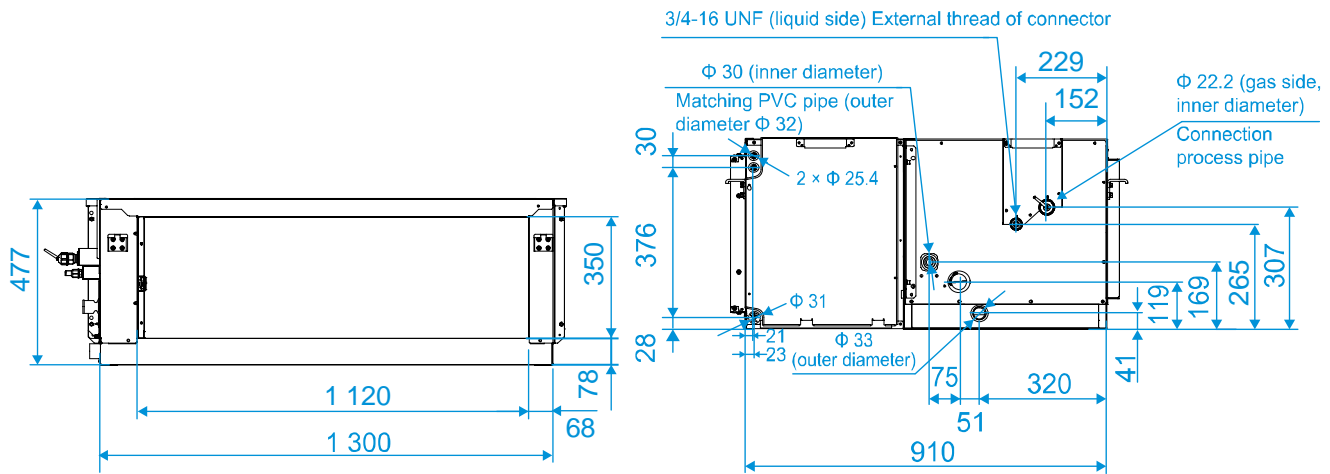

Dimensions of the air outlets:

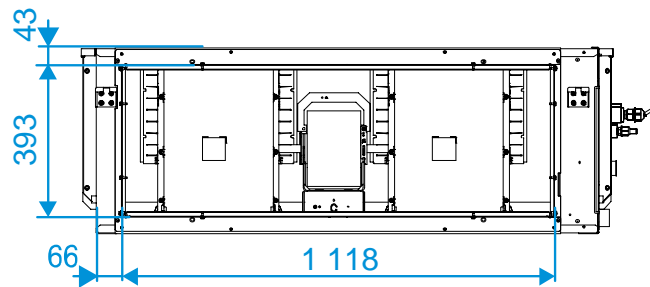

Dimensions of lugs and the screw hole of air outlet/inlet flange:

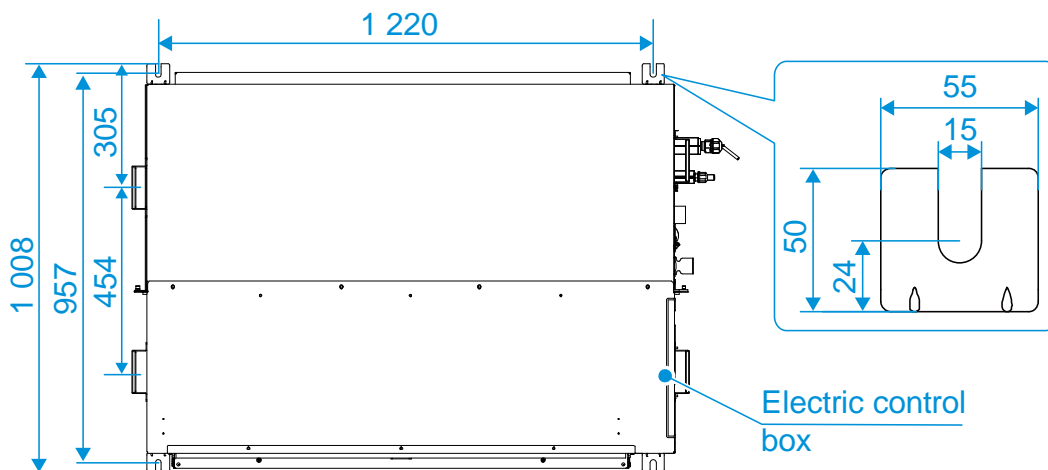

3 Unit Placement

3.1 Placement Considerations

Unit placement should take account of the following considerations:

- Units should not be installed in the following locations:
 - Where exposure to direct radiation from a high-temperature heat source or to interference from a source of electromagnetic radiation may occur.
 - Where dust or dirt may affect heat exchangers.
 - Where exposure to oil or to corrosive or harmful gases, such as acidic or alkaline gases, may occur.
 - Where exposure to salinity may occur, such as seaside locations.
 - Where highly flammable materials are present.
 - Where exposure to oily air may occur, such as a kitchen.
 - Where exposure to very high humidity may occur, such as a laundry.
- Units should be installed in positions where:
 - The ceiling is horizontal and is able to bear the unit's weight.
 - There are no obstructions that could impede the airflow into and out of the unit.
 - The airflow out of the unit can reach throughout the room.
 - There is sufficient space for access during installation, servicing and maintenance.
 - The refrigerant piping and drain piping can be easily connected to the refrigerant piping and drain piping systems.
 - Short-circuit ventilation (where outlet air returns quickly to a unit's air inlet) will not occur.

3.2 Space Requirements

Figure 3.1: High Static Pressure Duct space requirements (unit: mm)

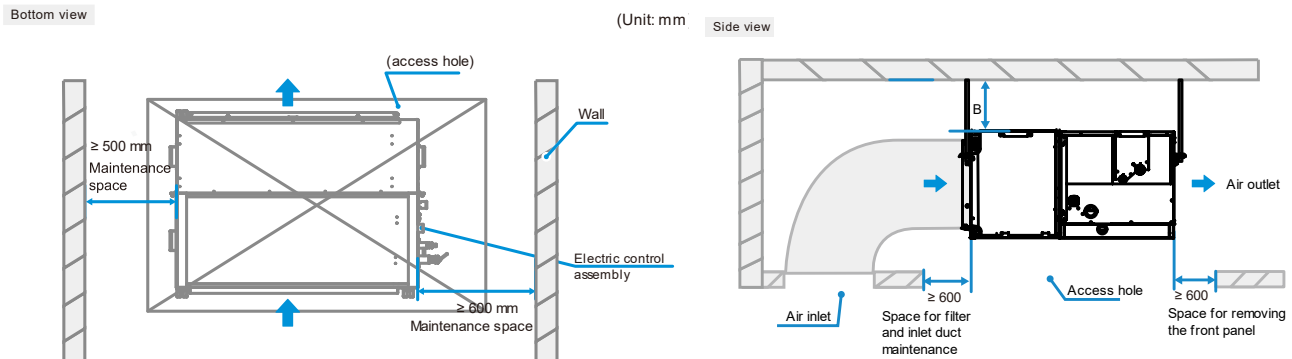

Notes for installers and service engineers

1. The distance between the indoor unit and the roof (B) shall be greater than 50mm to install the air duct.
2. The motor and fan can be maintained from the indoor unit top or the air outlet. If maintenance is performed from the indoor unit top, the distance between the indoor unit and the roof must be larger than 600mm. If maintenance is performed from the air outlet, the distance between the indoor unit and the roof must be larger than 200mm, with a minimum distance of 600mm allowed for removing the front panel.

4 Piping Diagram

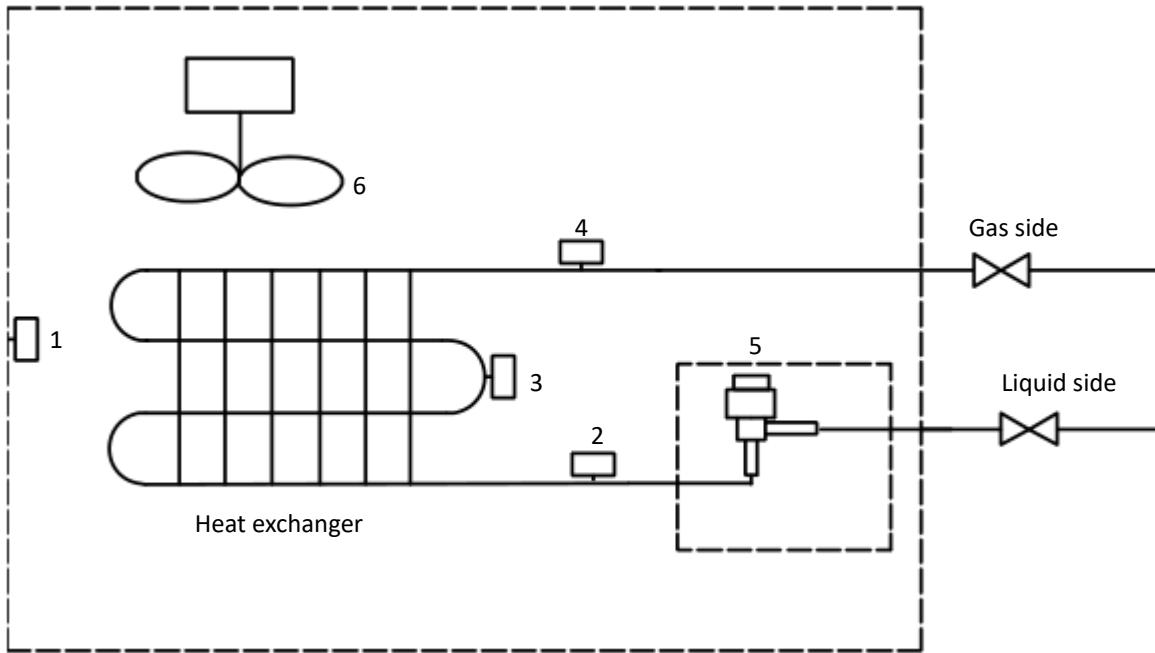

| Legend | | |
|--------|-----|----------------------------|
| 1 | T1 | Inlet Air Temp. Sensor |
| 2 | T2A | Liquid Pipe Temp. Sensor |
| 3 | T2 | Middle Pipe Temp. Sensor |
| 4 | T2B | Gas Pipe Temp. Sensor |
| 5 | EEV | Electronic expansion valve |
| 6 | FAN | Fan motor |

5 Wiring Diagram

Figure 5.1: High Static Pressure Duct wiring diagram

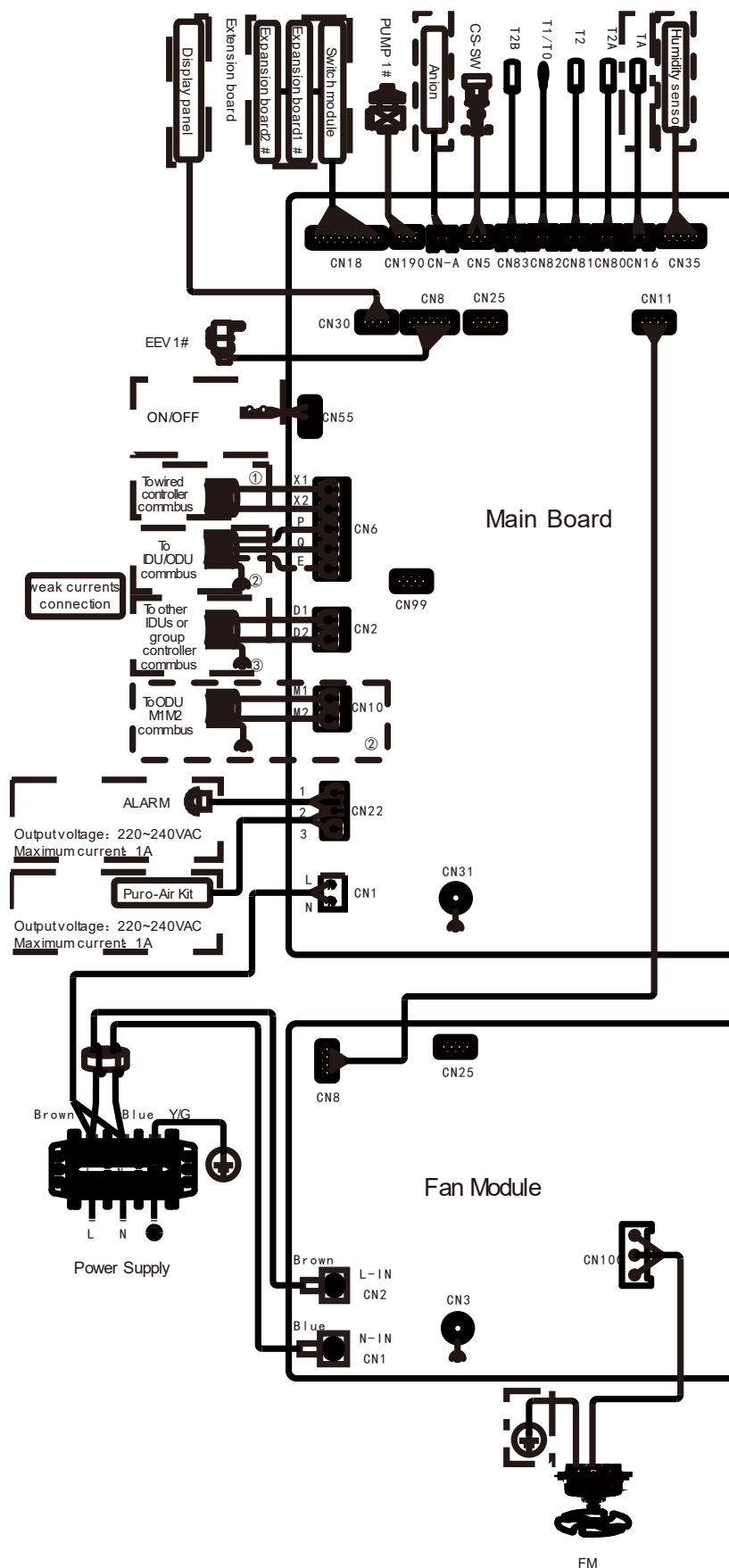

Midea Quantum Series (AU) Technical Service Manual

Notes for installers and service engineers **Caution**

- All installation, servicing and maintenance must be carried out by competent and suitably qualified, certified and accredited professionals and in accordance with all applicable legislation.
- Units should be grounded in accordance with all applicable legislation. Metal and other conductive components should be insulated in accordance with all applicable legislation.
- Power supply wiring should be securely fastened at the power supply terminals – loose power supply wiring would represent a fire risk.
- After installation, servicing or maintenance, the electric control box cover should be closed. Failing to close the electric control box cover risks fire or electric shock.
- The dotted lines indicate the field wiring or optional function.
- X1X2 communication ports can be connected to the wired controller.
- PQ and M1M2 communication ports both are used for indoor and outdoor communication, and only one of them can be used at a time. Meanwhile, be sure to connect the same communication ports (PQ to PQ; M1M2 to M1M2) in case of damage of the main control board.
- D1D2 communication ports are used for group control communication. When connecting the group controller, the D1D2 port of the indoor units that are to be group controlled must be connected in daisy chain, and the group controller must be connected to the X1X2 port of one of the indoor units in the group control, and set to group control mode. In addition, D1D2 communication ports can also be connected to the central controller.

6 Electrical Characteristics

| Model | Power supply | | | | | | Indoor Fan Motor |
|-----------------|--------------|---------|------------|------------|------|-----|------------------------|
| | Hz | Volts | Min. volts | Max. volts | MCA | MFA | Rated motor output (W) |
| DUCMI200IHC-3PH | 50/60 | 220-240 | 198 | 264 | 6.75 | 30 | 920 |
| DUCMI220IHC-3PH | 50/60 | 220-240 | 198 | 264 | 6.75 | 30 | 920 |

Abbreviations:

MCA: Minimum Circuit Amps

MFA: Maximum Fuse Amps

7 Sound Levels

7.1 Overall

Table 7.1: High Static Pressure Duct sound pressure levels¹

| Model name | Sound pressure levels dB(A) | | | | | | |
|-----------------|-----------------------------|----|----|----|------|----|-----|
| | SSH | SH | H | M | L | SL | SSL |
| DUCMI200IHC-3PH | 51 | 49 | 47 | 45 | 43.5 | 42 | 41 |
| DUCMI220IHC-3PH | 51 | 49 | 47 | 45 | 43.5 | 42 | 41 |

Notes:

- 1 Sound pressure levels are measured 1.4m below the unit in an anechoic chamber. During in-situ operation, sound pressure levels may be higher as a result of ambient noise.

Figure 7.1: High Static Pressure Duct sound pressure level measurement

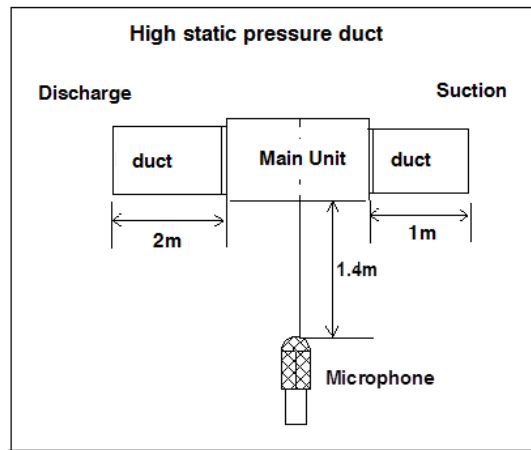

7.2 Octave Band Levels

Figure 7.2: DUCMI200IHC-3PH octave band levels

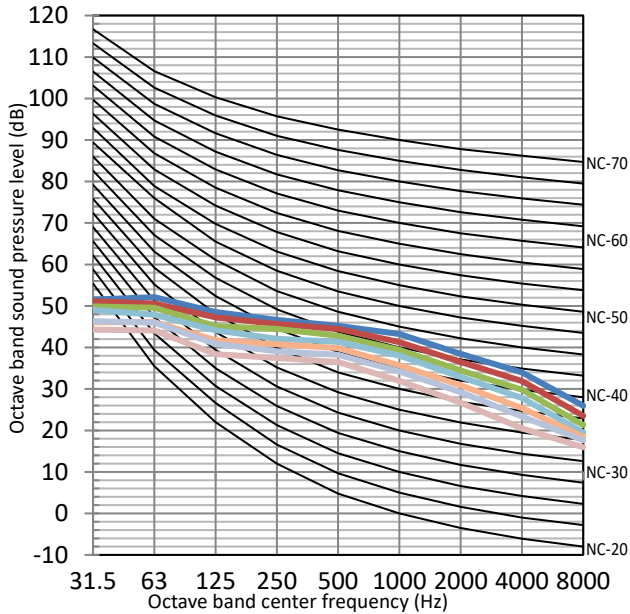
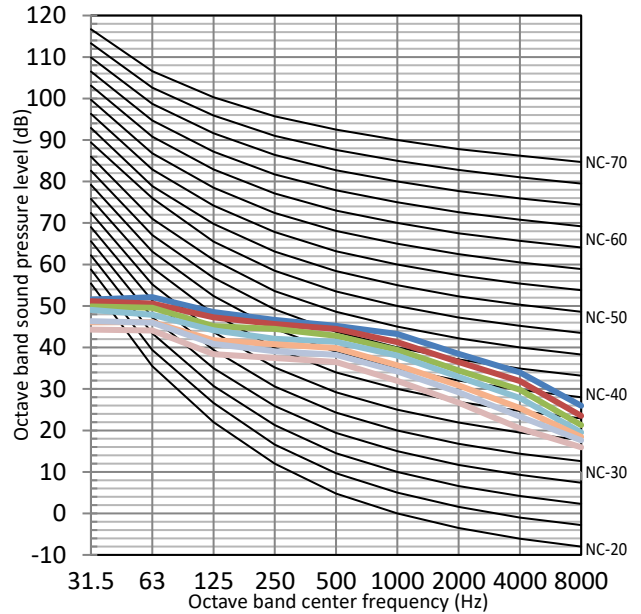

Figure 7.3: DUCMI220IHC-3PH octave band levels



8 Fan Performance

8.1 Constant Airflow mode

8.1.1 Fan performance diagram

Figure 8.1: DUCMI200IHC-3PH fan performance

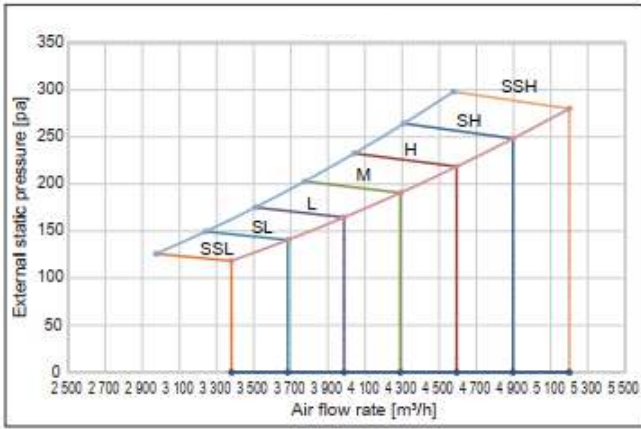
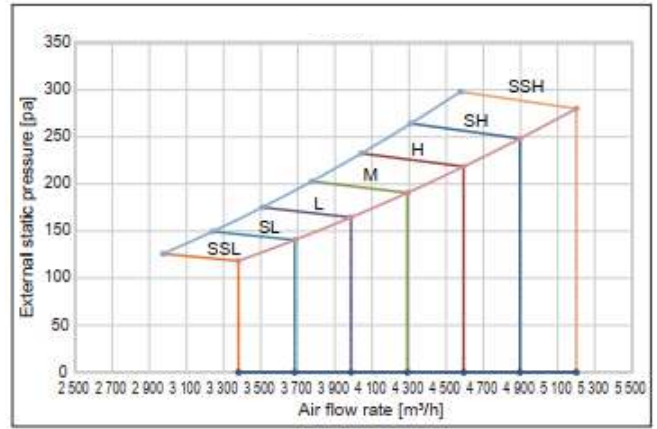

Figure 8.2: DUCMI220IHC-3PH fan performance



8.2 Constant Speed mode

8.2.1 Fan performance diagram

Figure 8.3: DUCMI200IHC-3PH fan performance

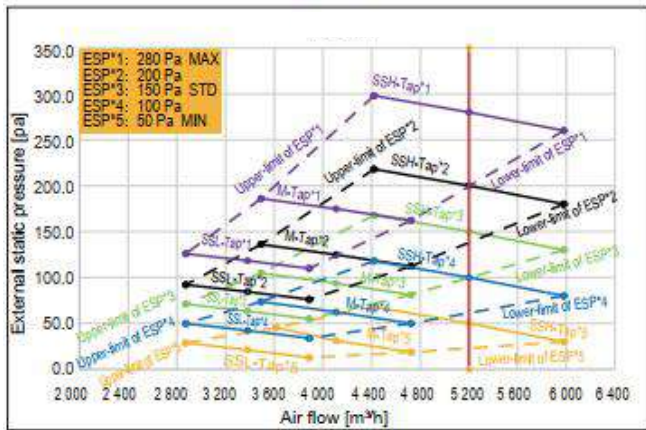
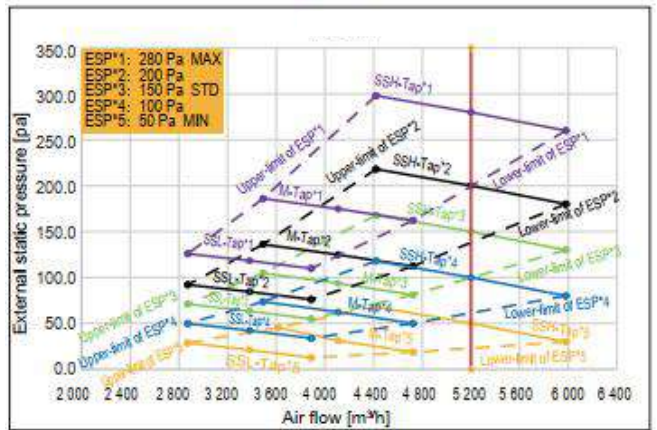

Figure 8.4: DUCMI220IHC-3PH fan performance



Part 4

System Design and Installation

| | |
|---|----|
| 1 Preface to Part 3 | 28 |
| 2 Unit Placement and Installation | 29 |
| 3 Refrigerant Piping Design | 31 |
| 4 Refrigerant Piping Installation | 33 |
| 5 Drain Piping | 40 |
| 6 Air Duct | 43 |
| 7 Insulation..... | 44 |
| 8 Charging Refrigerant | 45 |

1 Preface

1.1 Notes for Installers Boxes

The information contained in this Engineering Data Book may primarily be of use during the system design stage of a Midea VRF project. Additional important information which may primarily be of use during field installation has been placed in boxes, such as the example below, titled “Notes for installers”.

Notes for installers

- Notes for installers boxes contain important information which may primarily be of use during field installation, rather than during desk-based system design.

1.2 Definitions

In this Engineering Data Book, the term “applicable legislation” refers to all national, local and other laws, standards, codes, rules, regulations and other legislation that apply in a given situation.

1.3 Precautions

All system installation including installation of piping and electrical works must only be carried out by competent and suitably qualified, certified and accredited professionals and in accordance with all applicable legislation.

1.4 Installation procedure

Notes for installers

Installation of the system should proceed in the following order

Preparations
before installation

Refrigerant
piping design

Pipe and joints
installation

Pipe Flushing

Gastightness
test

Vacuum drying

Commissioning

Electrical
wiring layout

Refrigerant
charging

Pipe insulation

Drain piping installation

Note: Pipe flushing should be performed once the brazed connections have been completed with the exception of the final connections to the indoor units. That is, flushing should be performed once the outdoor units have been connected but before the indoor units are connected.

2 Unit Placement and Installation

2.1 Outdoor Units

2.1.1 Placement considerations

Placement of outdoor units should take account of the following considerations:

- Air conditioners should not be exposed to direct radiation from a high-temperature heat source.
- Air conditioners should not be installed in positions where dust or dirt may affect heat exchangers.
- Air conditioners should not be installed in locations where exposure to oil or to corrosive or harmful gases, such as acidic or alkaline gases, may occur.
- Air conditioners should not be installed in locations where exposure to salinity may occur unless the anti-corrosion treatment for high-salinity areas customization option has been added and the precautions described in Part 3, 9 “Installation in Areas of High Salinity” are taken.
- Outdoor units should be installed in well-drained, well-ventilated positions that are as close as possible to the indoor units.

2.1.2 Spacing

Outdoor units must be spaced such that sufficient air may flow through each unit. Sufficient airflow across heat exchangers is essential for outdoor units to function properly.

Figure 4-2.1: Single unit installation (unit: mm)

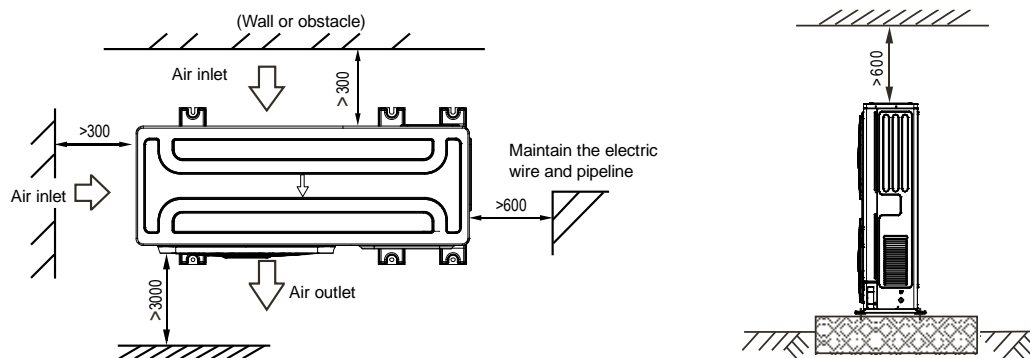
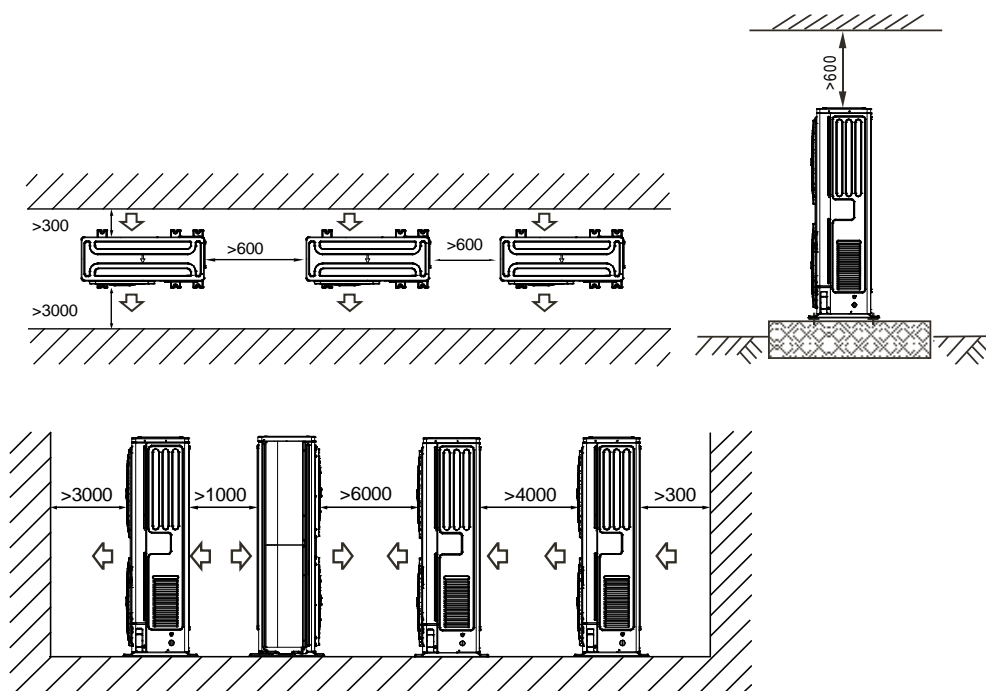

Figure 4-2.2: Two units or above installation (unit: mm)



2.2 Indoor Units

2.2.1 Placement considerations

Placement of indoor units should take account of the following considerations:

- Sufficient space for drain piping and for access during servicing and maintenance should be allowed.
- To ensure a good cooling/heating effect, short-circuit ventilation (where outlet air returns quickly to a unit's air inlet) should be avoided.
- To prevent excessive noise or vibration during operation, suspension rods or other weight-bearing fixings should typically be able to bear twice the unit's weight.

Notes for installers



- Before installing an indoor unit, check that the model to be installed is as specified in the construction drawings and confirm the correct orientation of the unit.
- Ensure that units are installed at the correct height.
- To allow smooth condensate drainage and to ensure unit stability (to prevent excessive noise or vibration), ensure that units are level to within 1° of the horizontal. If a unit is not level to within 1° of the horizontal, water leakage or abnormal vibration/noise may occur.

2.2.2 Space Requirements

Figure 4-2.3: High Static Pressure Duct space requirements (unit: mm)

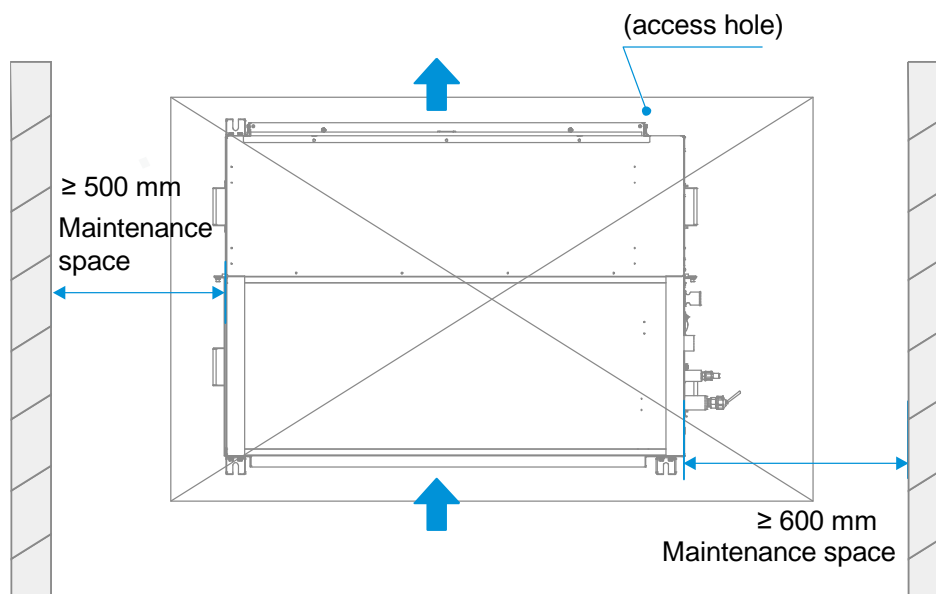

3 Refrigerant Piping Design

3.1 Permitted Piping Lengths and Level Differences

The piping length and level difference requirements that apply are summarized in table below.

Figure 4-3.1: Permitted refrigerant piping length and level differences

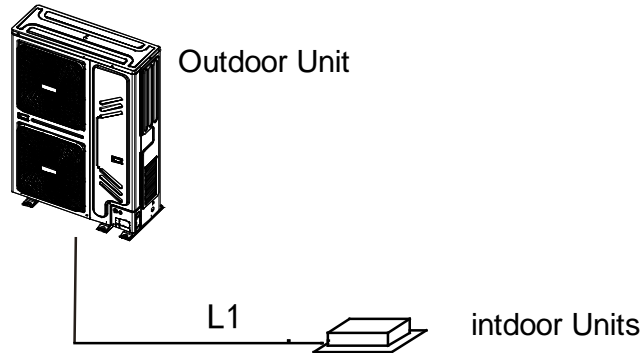

| Name | Designation |
|-----------|-------------|
| Main pipe | L1 |

Table 4-3.1: Summary of permitted refrigerant piping length and level differences

| Category | | Permitted values | Piping in Figure 4-3.1 |
|-------------------|---|-----------------------|------------------------|
| Piping lengths | The maximum piping length | $\leq 90\text{m}$ | L1 |
| Level differences | Largest level difference between indoor unit and outdoor unit | Outdoor unit is above | - |
| | | Outdoor unit is below | |

3.2 Selecting Piping Diameters

Selecting piping diameters between outdoor and indoor unit.

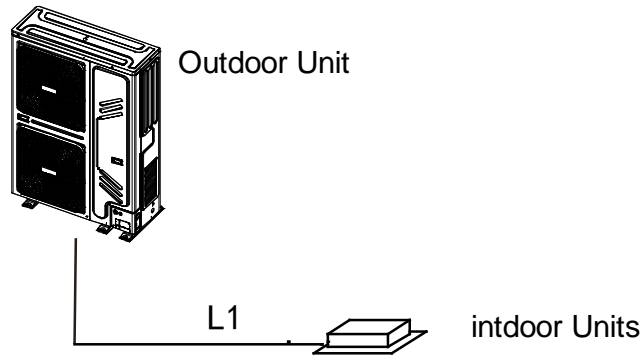

Table 4-3.2: Piping diameter of L1

| Outdoor units | Gas pipe (mm) | Liquid pipe (mm) |
|---------------|---------------|------------------|
| 20-22kW | Φ25.4 | Φ12.7 |

3.3 Refrigerant Leakage Precautions

R410A refrigerant is not flammable in air at temperatures up to 100°C at atmospheric pressure and is generally considered a safe substance to use in air conditioning systems. Nevertheless, precautions should be taken to avoid danger to life in the unlikely event of a major refrigerant leakage. Precautions should be taken in accordance with all applicable legislation. Where no applicable legislation exists, the following may be used as a guide:

- Air-conditioned rooms should be large enough that if leakage of all the refrigerant in the system occurs, the concentration of the refrigerant in the room does not reach a level dangerous to health.
- A critical concentration (at which point R410A becomes dangerous to human health) of 0.44 kg/m³ can be used.
- The potential concentration of refrigerant in a room following a leak can be calculated as follows:
 - Calculate the total amount of refrigerant in the system (“A”) as the nameplate charge (the charge in the system when delivered from the factory) plus the additional charge added as Part 4, 8.1 “Calculating Additional Refrigerant Charge”.
 - Calculate the total volume (“B”) of the smallest room into which refrigerant could potentially leak.
 - Calculate the potential refrigerant concentration as “A” divided by “B”.
 - If A/B is equal or more than 0.44 kg/m³, countermeasures such installing mechanical ventilators (either ventilating regularly or controlled by refrigerant leakage detectors) should be taken.
- Since R410A is heavier than air, particular consideration should be given to leak scenarios in basement rooms.

Figure 4-3.2: Mechanical ventilator controlled by refrigerant leak detector

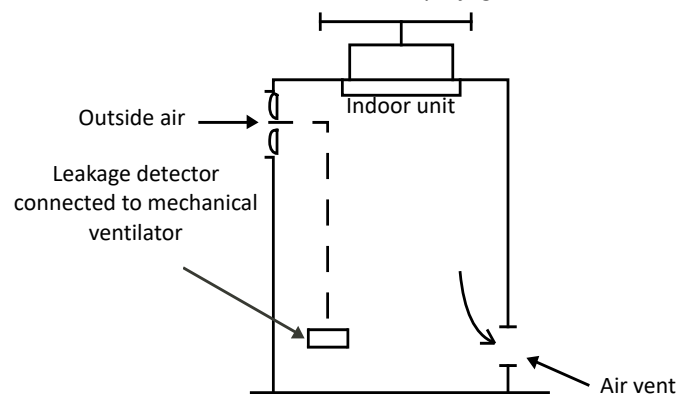

4 Refrigerant Piping Installation

4.1 Refrigerant pipe connection

Connect the Indoor units first, then connect the Outdoor unit.

Before connecting, knock off the plate in the corresponding direction.

Figure 4-4.1: The outdoor refrigerant connecting pipe position

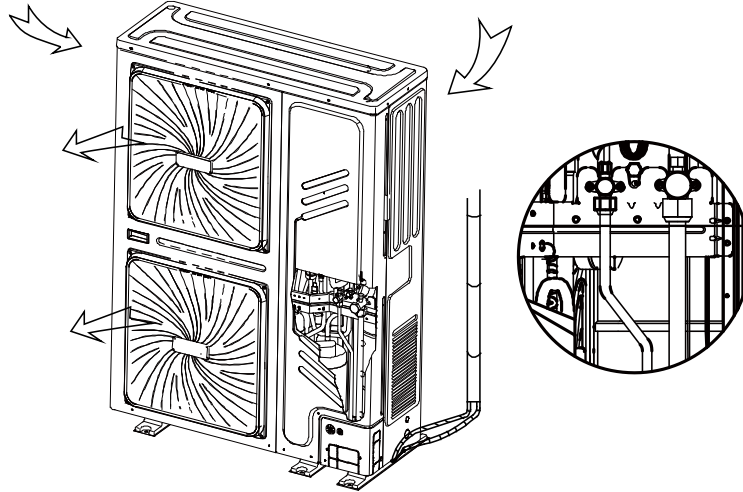

4.1.1 Cutting copper piping and removing burrs

Notes for installers



- Use a pipe cutter rather than a saw or cutting machine to cut piping. Rotate the piping evenly and slowly, applying even force to ensure that the piping does not become deformed during cutting. Using a saw or cutting machine to cut piping runs the risk of copper shavings entering the piping. Copper shavings are difficult to remove and pose a serious risk to the system if they enter the compressor or block the throttling unit.
- After cutting using a pipe cutter, use a reamer/scrapper to remove any burrs that have formed at the opening, keeping the opening of the piping downwards to avoid copper shavings from entering the piping.
- Remove burrs carefully to avoid scratches, which may prevent a proper seal being formed and lead to refrigerant leakage.

4.1.2 Bending piping

Bending copper piping reduces the number of brazed joints required and can improve quality and save material.

Notes for installers



Piping bending methods

- Hand bending is suitable for thin copper piping ($\Phi 6.35\text{mm} - \Phi 12.7\text{mm}$).
- Mechanical bending (using a bending spring, manual bending machine or powered bending machine) is suitable for a wide range of diameters ($\Phi 6.35\text{mm} - \Phi 54.0\text{mm}$).

Caution

- When using a spring bender, ensure that the bender is clean before inserting it in the piping.
- After bending a copper pipe, ensure that there are no wrinkles or deformation on either side of the pipe.
- Ensure that bend angles do not exceed 90° , otherwise wrinkles may appear on the inner side of the pipe, and the pipe may buckle or crack.
- Do not use a pipe that has buckled during the bending process; ensure that the cross section at the bend is greater than $2/3$ of the original area.

Figure 4-4.2: Pipe bending in excess of 90°

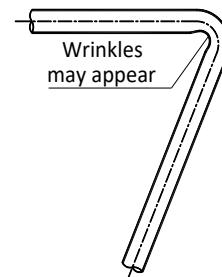

4.1.3 Flared joints

Flared joints should be used where a screw thread connection is required.

Notes for installers



- Before flaring 1/2H (half hard) piping, anneal the end of the pipe to be flared.
- Remember to place the flare nut on the piping before flaring.
- Ensure the flared opening is not cracked, deformed or scratched, otherwise it will not form a good seal and refrigerant leakage may occur.
- The diameter of the flared opening should be within the ranges specified in table below.

Table 4-4.1: Flared opening size ranges

| Pipe (mm) | Flared opening diameter (A) (mm) |
|-------------|----------------------------------|
| $\Phi 6.35$ | 8.7 - 9.1 |
| $\Phi 9.52$ | 12.8 - 13.2 |
| $\Phi 12.7$ | 16.2 - 16.6 |
| $\Phi 15.9$ | 19.3 - 19.7 |
| $\Phi 19.1$ | 23.6 - 24.0 |

Figure 4-4.3: Flared opening

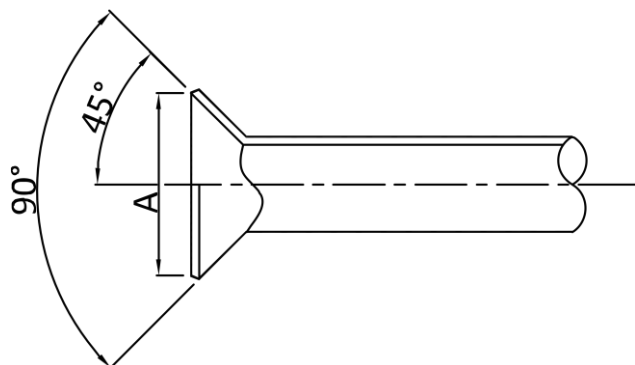

- When connecting a flared joint, apply some compressor oil to the inner and outer surfaces of the flared opening to facilitate the connection and rotation of the flare nut, ensure firm connection between the sealing surface and the bearing surface, and avoid the pipe becoming deformed.

4.1.4 Method of piping flaring connection

Connect the copper pipes to the indoor unit first, then connect it to the outdoor unit. You should first connect the low-pressure pipe, then the high-pressure pipe.

Notes for installers



- When connecting the flare nuts, apply a thin coat of refrigeration oil to the flared ends of the pipes.
- Align the center of the two pipes that you will connect. Remember to place the flare nut on the piping before flaring.
- The protective nut is a one-time part, it cannot be reused. In case it is removed, it should be replaced with a new one.
- According to the installation conditions, excessive torque can damage the horn mouth, while insufficient torque can cause air leakage. Please refer to the table below to determine the tightening torque in table below.

Table 4-4.2: Flared opening size ranges

| Pipe (mm) | Tightening torque |
|-----------|----------------------------------|
| Φ9.52 | 32.7~39.9 N.m (333~407 kgf.cm) |
| Φ19.1 | 97.2~118.6 N.m (990~1210 kgf.cm) |

Figure 4-4.4: Nut fastening

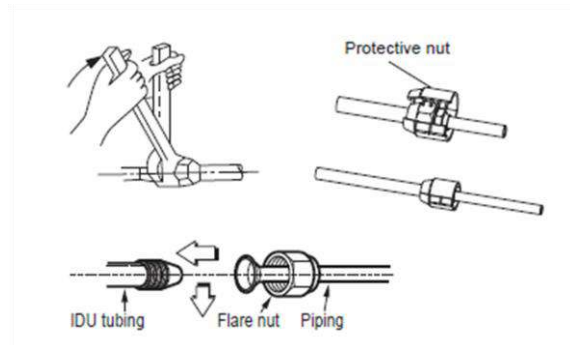

- When connecting a flared joint, apply some compressor oil to the inner and outer surfaces of the flared opening

4.1.5 Refrigerant Piping Supports

When the air conditioning is running, the refrigerant piping will deform (shrink, expand, droop). To avoid damage to piping, hangers or supports should be spaced as per the criteria in the table below. In general, the gas and liquid pipes should be suspended in parallel and the interval between support points should be selected according to the diameter of the gas pipe.

Table 4-4.3: Refrigerant piping support spacings

| Pipe (mm) | Interval between support points (m) | |
|-----------|-------------------------------------|-----------------|
| | Horizontal Piping | Vertical Piping |
| < Φ20 | 1 | 1.5 |
| Φ20 – Φ40 | 1.5 | 2 |
| > Φ40 | 2 | 2.5 |

Suitable insulation should be provided between the piping and the supports. If wooden dowels or blocks are to be used, use wood that has undergone preservative treatment.

Changes in refrigerant flow direction and refrigerant temperature result in movement, expansion and shrinkage of the refrigerant piping. Piping should therefore not be fixed too tightly, otherwise stress concentrations may occur in the piping, with the potential for rupturing.

4.2 Pipe Flushing

4.2.1 Purpose

To remove dust, other particles and moisture, which could cause compressor malfunction if not flushed out before the system is run, the refrigerant piping should be flushed using nitrogen. As described in Part 4, "Installation procedure", pipe flushing should be performed once the piping connections have been completed with the exception of the final connections to the indoor units. That is, flushing should be performed once the outdoor units have been connected but before the indoor units are connected.

4.2.2 Procedure

Notes for installers



Warning

Only use nitrogen for flushing. Using carbon dioxide risks leaving condensation in the piping. Oxygen, air, refrigerant, flammable gases and toxic gases must not be used for flushing. Use of such gases may result in fire or explosion.

Procedure

The liquid and gas sides can be flushed simultaneously; alternatively, one side can be flushed first and then Steps 1 to 8 repeated, for the other side. The flushing procedure is as follows:

1. Cover the inlets and outlets of the indoor units to prevent dirt getting blown in during pipe flushing. (Pipe flushing should be carried out before connecting the indoor units to the piping system.)
2. Attach a pressure reducing valve to a nitrogen cylinder.
3. Connect the pressure reducing valve outlet to the inlet on the liquid (or gas) side of the outdoor unit.
4. Use blind plugs to block all liquid (gas) side openings, except for the opening at the indoor unit which is furthest from the outdoor units ("Indoor unit A" in figure below).
5. Start to open the nitrogen cylinder valve and gradually increase the pressure to 0.5MPa.
6. Allow time for nitrogen to flow as far as the opening at indoor unit A.
7. Flush the first opening:
 - a) Using suitable material, such as a bag or cloth, press firmly against the opening at indoor unit A.
 - b) When the pressure becomes too high to block with your hand, suddenly remove your hand allowing gas to rush out.
 - c) Repeatedly flush in this manner until no further dirt or moisture is emitted from the piping. Use a clean cloth to check for dirt or moisture being emitted. Seal the opening once it has been flushed.
8. Flush the other openings in the same manner, working in sequence from indoor unit A towards the outdoor units. Refer to figure below.
9. Once flushing is complete, seal all openings to prevent dust and moisture from entering.

Figure 4-4.5: Pipe flushing using nitrogen

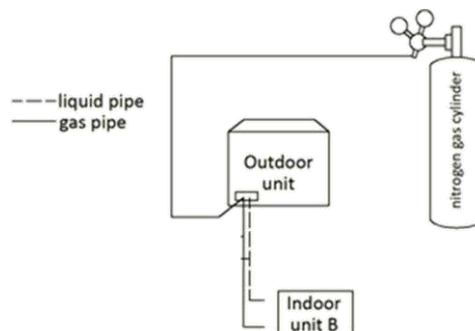

4.3 Gastightness Test

4.3.1 Purpose

To prevent faults caused by refrigerant leakage, a gastightness test should be performed before system commissioning.

4.3.2 Procedure

Notes for installers



Warning

Only dry nitrogen should be used for gastightness testing. Oxygen, air, flammable gases and toxic gases must not be used for gastightness testing. Use of such gases may result in fire or explosion.

Procedure

The gastightness test procedure is as follows:

Step 1

- Once the piping system is complete and the indoor and outdoor units have been connected, vacuum the piping to -0.1MPa.

Step 2

- Charge the indoor piping with nitrogen at 0.3MPa through the needle valves on the liquid and gas stop valves and leave for at least 3 minutes (do not open the liquid or gas stop valves). Observe the pressure gauge to check for large leakages. If there is a large leakage, the pressure gauge will drop quickly.
- If there are no large leakages, charge the piping with nitrogen at 1.5MPa and leave for at least 3 minutes. Observe the pressure gauge to check for small leakages. If there is a small leakage, the pressure gauge will drop distinctly.
- If there are no small leakages, charge the piping with nitrogen at 4.2MPa and leave for at least 24 hours to check for micro leakages. Micro leakages are difficult to detect. To check for micro leakages, allow for any change in ambient temperature over the test period by adjusting the reference pressure by 0.01MPa per 1°C of temperature difference. Adjusted reference pressure = Pressure at pressurization + (temperature at observation – temperature at pressurization) x 0.01MPa. Compare the observed pressure with the adjusted reference pressure. If they are the same, the piping has passed the gastightness test. If the observed pressure is lower than the adjusted reference pressure, the piping has a micro leakage.
- If the leakage is detected, refer to Part 3, 4.3.3 “Leak detection”. Once the leak has been found and fixed, the gastightness test should be repeated.

Step 3

- If not continuing straight to vacuum drying once the gastightness test is complete, reduce the system pressure to 0.5-0.8MPa and leave the system pressurized until ready to carry out the vacuum drying procedure.

Figure 4-4.6: Gastightness test

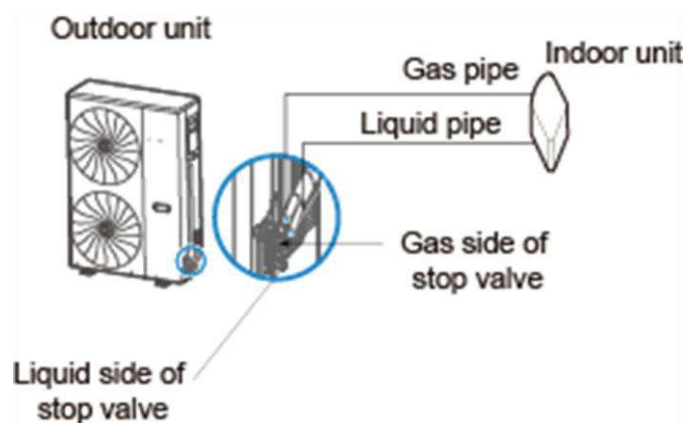

Notes for installers



To check for leaks: Vacuum leak test

1. Evacuate the system from the liquid and gas piping to -100.7 kPa (-1.007 bar) (5 Torr absolute) for more than 2 hours.
2. Once reached, turn off the vacuum pump and check that the pressure does not rise for at least 1 minute.
3. Should the pressure rise, the system may either contain moisture (see vacuum drying below) or have leaks.

To check for leaks: Pressure leak test

1. Test for leaks by applying a bubble test solution to all piping connections.
2. Discharge all nitrogen gas.
3. Break the vacuum by pressurizing with nitrogen gas to a minimum gauge pressure of 0.2 MPa (2 bar). Never set the gauge pressure higher than the maximum operation pressure of the unit, i.e. 4.0 MPa (40 bar)

ALWAYS use a recommended bubble test solution from your wholesaler.

NEVER use soap water:

Soap water may cause cracking of components, such as flare nuts or stop valve caps.

Soap water may contain salt, which absorbs moisture that will freeze when the piping gets cold.

Soap water contains ammonia which may lead to corrosion of flared joints (between the brass flare nut and the copper flare).

4.4 Vacuum Drying

4.4.1 Purpose

Vacuum drying should be performed in order to remove moisture and non-condensable gases from the system. Removing moisture prevents ice formation and oxidization of copper piping or other internal components. The presence of ice particles in the system would cause abnormal operation, whilst particles of oxidized copper can cause compressor damage. The presence of non-condensable gases in the system would lead to pressure fluctuations and poor heat exchange performance.

Vacuum drying also provides additional leak detection (in addition to the gastightness test).

4.4.2 Procedure

Notes for installers



During vacuum drying, a vacuum pump is used to lower the pressure in the piping to the extent that any moisture present evaporates. At 5mmHg (755mmHg below typical atmospheric pressure) the boiling point of water is 0°C. Therefore a vacuum pump capable of maintaining a pressure of -756mmHg or lower should be used. Using a vacuum pump with a discharge in excess of 4L/s and a precision level of 0.02mmHg is recommended.

Caution

- Before performing vacuum drying, make sure that all the outdoor unit stop valves are firmly closed.
- Once the vacuum drying is complete and the vacuum pump is stopped, the low pressure in the piping could suck vacuum pump lubricant into the air conditioning system. The same could happen if the vacuum pump stops unexpectedly during the vacuum drying procedure. Mixing of pump lubricant with compressor oil could cause compressor malfunction and a one-way valve should therefore be used to prevent vacuum pump lubricant seeping into the piping system.

Procedure

The vacuum drying procedure is as follows:

Step 1

- Connect the blue (low pressure side) hose of a pressure gauge to the master unit gas pipe stop valve, the red (high pressure side) hose to the master unit liquid pipe stop valve and the yellow hose to the vacuum pump.

Step 2

- Start the vacuum pump and then open the pressure gauge valves to start vacuum the system.
- After 30 minutes, close the pressure gauge valves.
- After a further 5 to 10 minutes check the pressure gauge. If the gauge has returned to zero, check for leakages in the refrigerant piping.

Step 3

- Re-open the pressure gauge valves and continue vacuum drying for at least 2 hours and until a pressure difference (below typical atmospheric pressure) of 756mmHg or more has been achieved. Once the pressure difference of at least 756mmHg has been achieved, continue vacuum drying for 2 hours.

Step 4

- Close the pressure gauge valves and then stop the vacuum pump.
- After 1 hour, check the pressure gauge. If the pressure in the piping has not increased, the procedure is finished. If the pressure has increased, check for leakages.
- After vacuum drying, **keep the blue and red hoses connected to the pressure gauge and to the master unit stop valves**, in preparation for refrigerant charging.

Figure 4-4.7: Vacuum drying

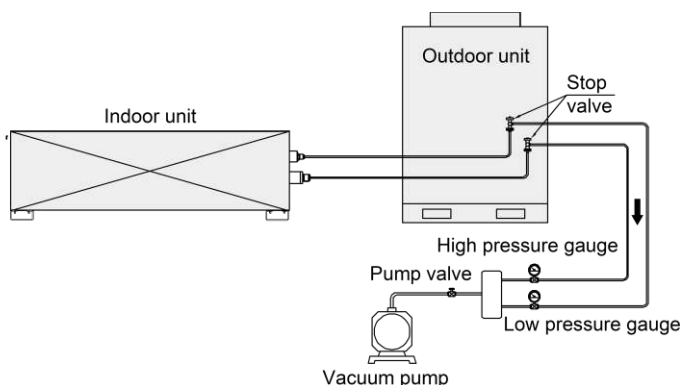

Pressure gauge

5 Drain Piping

5.1 Design Considerations

Drain piping design should take account of the following considerations:

- Indoor unit condensate drain piping needs to be of sufficient diameter to carry the volume of condensate produced at the indoor units and installed at a slope sufficient to allow drainage. Discharge as close as possible to the indoor units is usually preferable.
- To prevent the drain piping becoming excessively long, consideration should be given to installing multiple drain piping systems, with each system having its own drainage point and providing drainage for a subset of the overall set of indoor units.
- The routing of drain piping should take into consideration the need to maintain sufficient slope for drainage whilst avoiding obstacles such as beams and ducting. The drain piping slope should be at least 1:100 away from indoor units.

Figure 4-5.1: Drain piping minimum slope requirement

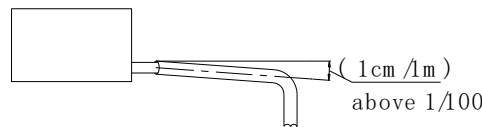

- To avoid backflow and other potential complications, two horizontal drain pipes should not meet at the same level. Refer to the figure below for suitable connection arrangements. Such arrangements also allow the slope of the two horizontal pipes to be selected independently.

Figure 4-5.2: Drain piping joints – correct and incorrect configurations

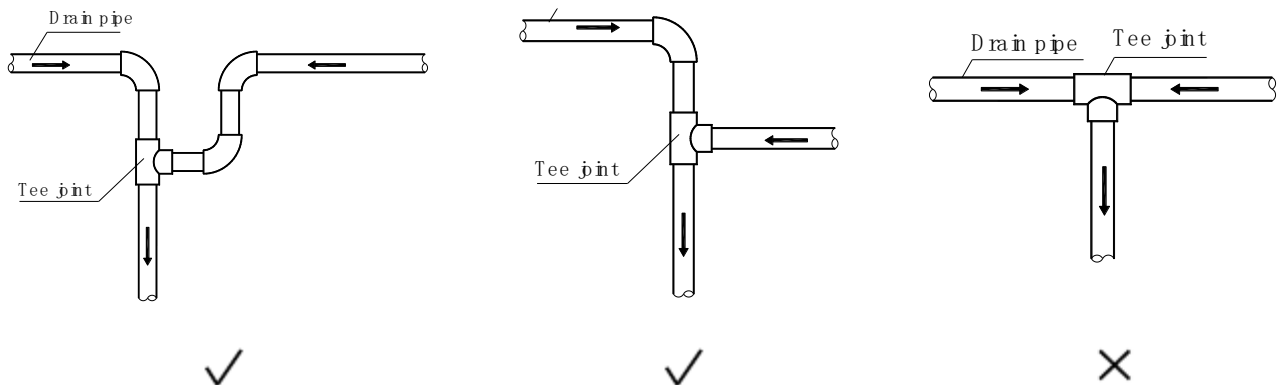

- Branch drain piping should join main drain piping from the top.
- Recommended support/hanger spacing is 0.8 – 1.0m for horizontal piping and 1.5 – 2.0m for vertical piping. Each vertical section should be fitted with at least two supports. For horizontal piping, spacing greater than those recommended leads to sagging and deformation of the pipe profile at the supports which impedes water flow and should therefore be avoided.
- Air vents should be fitted at the highest point of each drain piping system to ensure that condensation is discharged smoothly. U-bends or elbow joints should be used such that the vents face downwards, to prevent dust entering the piping. Air outlet should not be installed too close to indoor unit lift pumps.

Figure 4-5.3: Branch drain piping joining main drain piping

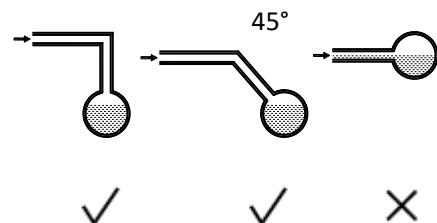

Figure 4-5.4: Effect of insufficient drain piping support

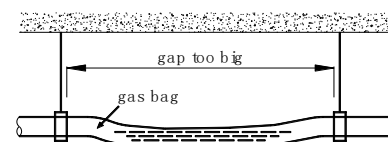
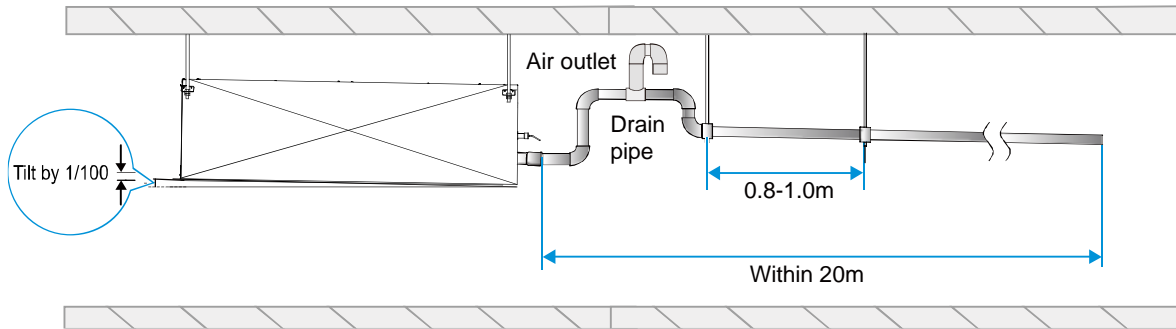

Figure 4-5.5: Drain piping air outlet



- Air conditioner drain piping should be installed separately from waste, rainwater and other drain piping and should not come into direct contact with the ground.
- Drain piping diameter should be not less than the indoor units' drain piping connection.
- To allow inspection and maintenance, the piping clamps shipped with units should be used to attach drain piping to indoor units – adhesive should not be used.
- Thermal insulation should be added to drain piping to prevent condensation forming. Thermal insulation should extend all the way to the connection with the indoor unit.
- Units with drain pumps should have separate drain piping systems from systems that use natural drainage.

5.2 Water Traps

For indoor units with a high negative pressure differential at the outlet of the drainage pan, a trap should be fitted to the drain piping to prevent poor drainage and/or water being blown back into the drainage pan. Traps should be arranged as in Figure 4-5.6. The vertical separation H should be in excess of 50mm. A plug may be fitted to allow cleaning or inspection.

Figure 4-5.6: Drain piping water traps

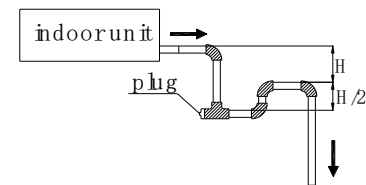

5.3 Selecting Piping Diameters

Select branch drainage piping (the drain piping connection to each unit) diameters according to indoor unit flow volume and select main drainage piping diameters according to the combined flow volume of the upstream indoor units. Use a design assumption of 2 liters of condensate per horsepower per hour. For example, the combined flow volume of three 2HP units and two 1.5HP units would be calculated as follows:

$$\begin{aligned} \text{Combined flow volume} &= 3 \times 2 \text{ L/HP/h} \times 2\text{HP} + 2 \times 2 \text{ L/HP/h} \times 1.5\text{HP} \\ &= 18 \text{ L/h} \end{aligned}$$

Tables below specify the required piping diameters for horizontal and vertical branch piping and for main piping. Note that main piping should use PVC40 or larger.

Table 4-5.1: Horizontal drain piping diameters

| PVC piping | Nominal diameter (mm) | Capacity (L/h) | | Remarks |
|------------|-----------------------|----------------|-------------|-----------------------|
| | | Slope 1:50 | Slope 1:100 | |
| PVC25 | 25 | 39 | 27 | Branch piping only |
| PVC32 | 32 | 70 | 50 | |
| PVC40 | 40 | 125 | 88 | Branch or main piping |
| PVC50 | 50 | 247 | 175 | |
| PVC63 | 63 | 473 | 334 | |

Table 4-5.2: Vertical drain piping diameters

| PVC piping | Nominal diameter (mm) | Capacity (L/h) | Remarks |
|------------|-----------------------|----------------|-----------------------|
| PVC25 | 25 | 220 | Branch piping only |
| PVC32 | 32 | 410 | |
| PVC40 | 40 | 730 | Branch or main piping |
| PVC50 | 50 | 1440 | |
| PVC63 | 63 | 2760 | |
| PVC75 | 75 | 5710 | |
| PVC90 | 90 | 8280 | |

5.4 Drain Piping Installation

Notes for installers



Installation of the drain piping should proceed in the following order:



Caution

- Ensure that all joints are firm and once the drain piping is all connected conduct a watertightness test and water flow test.
- Do not connect air conditioner drain piping to waste, rainwater or other drain piping and do not let air conditioner drain piping come into direct contact with the ground.
- For units with drain pumps, test that the drain pump functions properly by adding water to the unit's drainage pan and running the unit. To allow inspection and maintenance, the pipe clamps shipped with units should be used to attach drain piping to indoor units – adhesive should not be used.

5.5 Watertightness Test and Water Flow Test

Once installation of a drainage piping is complete, watertightness and water flow tests should be performed.

Notes for installers



Watertightness test

- Fill the piping with water and test for leakages over a 24-hour period.

Water flow test (natural drainage test)

- Slowly fill the drainage pan of each indoor unit with at least 600ml of water through the inspection port and check that the water is discharged through the outlet of the drain piping.

Caution

- The drain plug in the drainage pan is for removing accumulated water prior to performing indoor unit maintenance. During normal operation, the drain should be plugged to prevent leakage.

6 Air Duct

6.1 Design Considerations

- Please use locally purchased air ducts and soft air ducts (Use environmentally friendly, odorless materials, otherwise the air conditioner may generate odor when it runs).
- Install the flange at the air return side, and use aluminum foil tape to seal the connection part between the flange and the air duct to avoid air leakage.
- Use aluminum foil tape to seal the connection part between the flange at the air supply side and the air duct to avoid air leakage.
- The air ducts on the air supply side shall be insulated to prevent condensation.
- When installing the air duct and its components, need to fix and adjust the supports and suspension brackets to ensure they are in the right position and subject to uniform force.
- Make sure that the air duct and its components are clean before installation.
- After installation, carry out the air tightness test on the air duct to ensure its air leakage.

Figure 4-6.1: Air ducts design

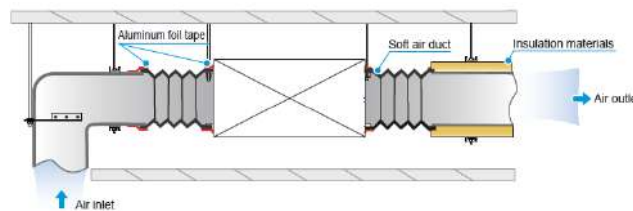

6.2 Procedure

Notes for installers



Warning

- Connect the air outlet and air inlet to the ceiling opening properly to avoid short circuit.
- Use canvas or soft air duct to connect the indoor unit and air duct at a distance (width) of 150-300mm.
- Do not lay wires, cables or other pipes containing toxic, flammable, and explosive gases or liquids inside the air ducts.
- The air duct regulating device shall be installed in a position that is easily accessible, flexible, and reliable.
- The air duct should be securely connected to the vent.
- The frame shall fit snugly into the building decoration, and should appear neat and flexible. It shall not be twisted or warped.
- If the air vent is installed horizontally, its deviation shall not exceed 3/1000; if installed vertically, its deviation shall not exceed 2/1000.
- All the air vents in one room shall be neatly installed at the same height.
- All metal accessories (including supports, suspension brackets, and brackets) for the piping system shall undergo anti-corrosion treatment.

Figure 4-6.2: Connection between air vent and air duct

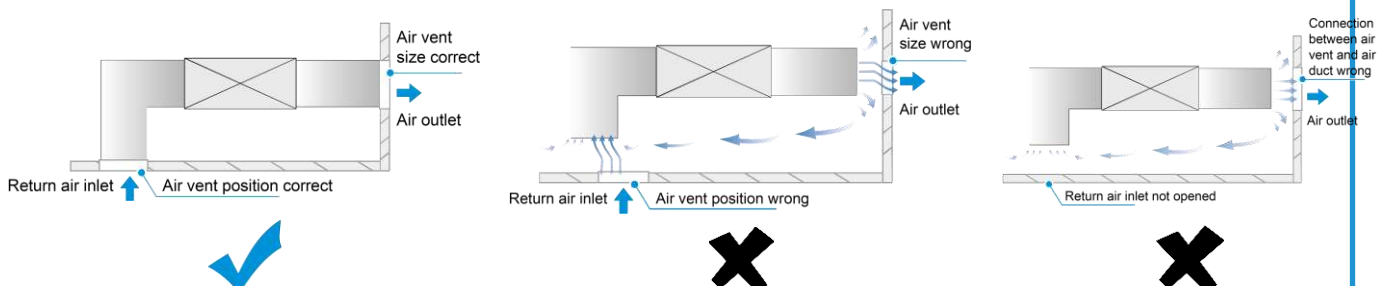

7 Insulation

7.1 Refrigerant Piping Insulation

During operation, the temperature of the refrigerant piping varies. Insulation is required to ensure unit performance and compressor lifespan. During cooling, the gas pipe temperature can be very low. Insulation prevents condensation forming on the piping. During heating, the gas pipe temperature can be very high. Insulation serves as necessary protection from burns.

7.1.1 Selecting insulation materials

Use heat-resistant polyethylene foam for the liquid pipes (able to withstand temperature of 70°C), and polyethylene foam for the gas pipes (able to withstand temperature of 120°C).

7.1.2 Thickness of insulation

Minimum thicknesses for refrigerant piping insulation are specified in table below. In hot, humid environments, the thickness of insulation should be increased over and above the specifications in table below.

Table 4-7.1: Refrigerant piping insulation thickness

| Pipe outer diameter (mm) | Minimum insulation thickness (mm) Humidity < 80%RH | Minimum insulation thickness (mm) Humidity ≥ 80%RH |
|--------------------------|---|---|
| Φ6.35 | 15 | 20 |
| Φ9.52 | | |
| Φ12.7 | | |
| Φ15.9 | | |
| Φ19.1 | | |
| Φ22.2 | | |
| Φ25.4 | | |

7.1.3 Installation of piping insulation

With the exception of joint insulation, insulation should be applied to piping before fixing the piping in place. Insulation at joints in refrigerant piping should be applied after the gastightness test has been completed.

Notes for installers



- Installation of insulation should be carried out in a manner suited to the type of insulation material being used.
- Ensure there are no gaps at the joints between sections of insulation.
- Do not apply tape too tightly as doing so may shrink insulation, reducing its insulating properties leading to condensation and loss of efficiency.
- Insulate gas and liquid pipes separately, otherwise heat exchange between the two sides will greatly impact efficiency.
- Do not bind the separately insulated gas and liquid pipes together too tightly as doing so can damage the joints between sections of insulation.

7.2 Drain Piping Insulation

- Use rubber/plastic insulating tube with a B1 fire resistance rating.
- The insulation should typically be in excess of 10mm thick.
- For drain piping installed inside a wall, insulation is not required.
- Use suitable adhesive to seal seams and joints in the insulation and then bind with cloth reinforced tape of width not less than 50mm. Ensure tape is fixed firmly to avoid condensation.
- Ensure the drain piping insulation adjacent to the indoor unit drainage water outlet is fixed to the unit itself using adhesive, to prevent condensation and dripping.

7.3 Ducting Insulation

Suitable insulation should be added to ducting in according with all applicable legislation.

8 Charging Refrigerant

8.1 Calculating Additional Refrigerant Charge

The additional refrigerant charge required depends on the lengths and diameters of the outdoor and indoor liquid pipes. Table 4-8.1 shows the additional refrigerant charge required per meter of equivalent pipe length for different diameters of pipe. The total additional refrigerant charge is obtained by summing the additional charge requirements for each of the outdoor and indoor liquid pipes, as in the following formula, where L_1 to L_8 represent the equivalent lengths of the pipes of different diameters. Assume 0.5m for the equivalent pipe length of each branch joint.

$$\begin{aligned} \text{Additional refrigerant charge R (kg)} &= L_1 (\Phi 6.35) \times 0.022 \\ &+ L_2 (\Phi 9.52) \times 0.057 \\ &+ L_3 (\Phi 12.7) \times 0.110 \\ &+ L_4 (\Phi 15.9) \times 0.170 \\ &+ L_5 (\Phi 19.1) \times 0.260 \\ &+ L_6 (\Phi 22.2) \times 0.360 \end{aligned}$$

Table 4-8.1: Additional refrigerant charge

| Liquid side piping (mm) | Additional refrigerant charge per meter of equivalent length of piping (kg) |
|-------------------------|---|
| Φ6.35 | 0.022 |
| Φ9.52 | 0.057 |
| Φ12.7 | 0.110 |
| Φ15.9 | 0.170 |
| Φ19.1 | 0.260 |
| Φ22.2 | 0.360 |

Notes:

- If the connection pipeline (L1) is less than or equal to 20m, no additional refrigerant is required.
- If the connection pipeline (L1) is longer than 20m, the refrigerant amount of 20m pipeline must be deducted from the final calculated additional refrigerant amount.

8.2 Adding Refrigerant

Notes for installers



Caution

- Only charge refrigerant after performing a gastightness test and vacuum drying.
- Never charge more refrigerant than required as doing so can lead to liquid hammering.
- Only use refrigerant R410A - charging with an unsuitable substance may cause explosions or accidents.
- Use tools and equipment designed for use with R410A to ensure required pressure resistance and to prevent foreign materials from entering the system.
- Refrigerant must be treated in accordance with applicable legislation.
- Always use protective gloves and protect your eyes when charging refrigerant.
- Open refrigerant containers slowly, and the power supply for all outdoor units should be turned on.
- The power supply for all outdoor units should be turned on, when add refrigerant

Notes for installers

**Procedure**

The procedure for adding refrigerant is as follows:

Step 1

- Calculate additional refrigerant charge R (kg).

Step 2

- Place a tank of R410A refrigerant on a weighing scale. Turn the tank upside down to ensure refrigerant is charged in a liquid state. (R410A is a blend of two different chemicals compounds. Charging gaseous R410A into the system could mean that the refrigerant charged is not of the correct composition).
- After vacuum drying, the blue and red pressure gauge hoses should still be connected to the pressure gauge and to the outdoor unit stop valves.
- Connect the yellow hose from the pressure gauge to the R410A refrigerant tank.

Step 3

- Open the valve where the yellow hose meets the pressure gauge, and open the refrigerant tank slightly to let the refrigerant eliminate the air. Caution: open the tank slowly to avoid freezing your hand.
- Set the weighing scale to zero.

Step 4

- Open the three valves on the pressure gauge to begin charging refrigerant.
- When the amount charged reaches R (kg), close the three valves. If the amount charged has not reached R (kg) but no additional refrigerant can be charged, close the three valves on the pressure gauge, run the outdoor units in cooling mode, and then open the yellow and blue valves. Continue charging until the full R (kg) of refrigerant has been charged, then close the yellow and blue valves. Note: Before running the system, be sure to complete all the pre-commissioning checks and be sure to open all stop valves as running the system with the stop valves closed would damage the compressor.

Figure 4-8.1: Charging refrigerant

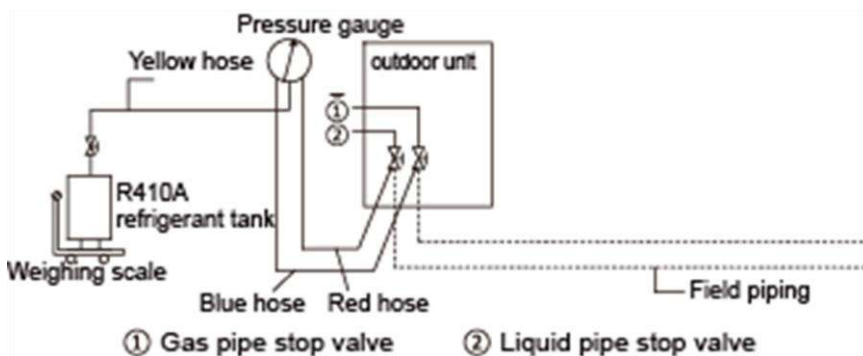

Pressure gauge

Part 5

Electrical Components and Wiring Diagrams

| | | |
|---|---|----|
| 1 | Outdoor Unit Electric Control Box Layout | 48 |
| 2 | Outdoor Unit Main PCB | 49 |
| 3 | Compressor Inverter Module and Filter Board | 56 |
| 4 | Wiring Diagrams | 60 |

1 Outdoor Unit Electric Control Box Layout

Figure 5-1.1: Front view of electric control box

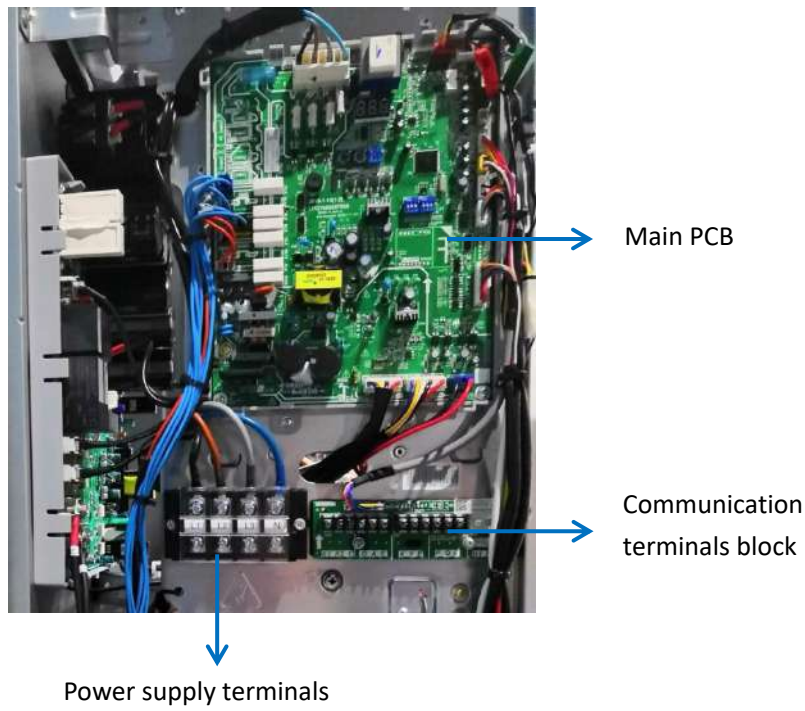
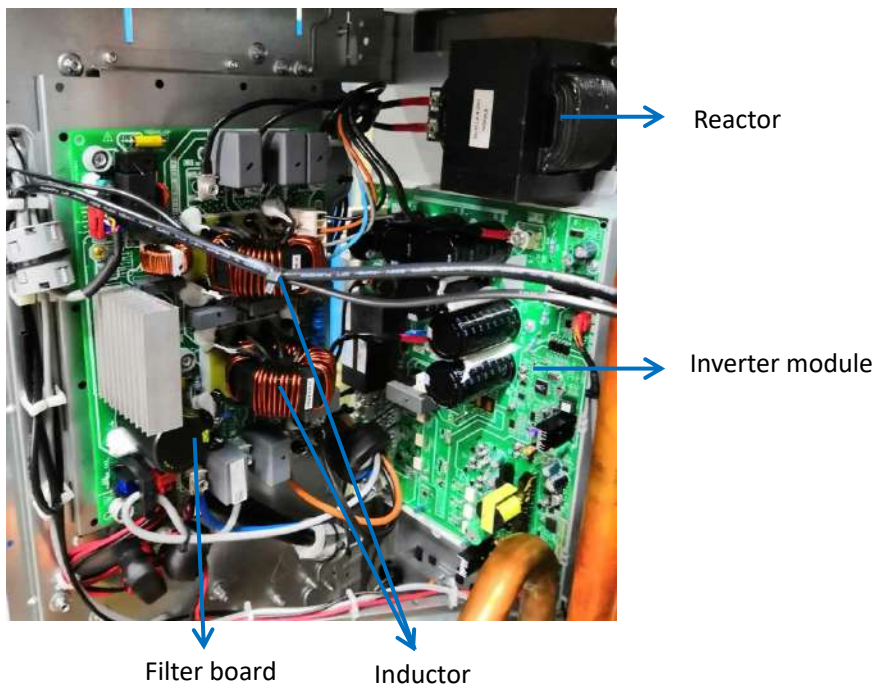

Figure 5-1.2: Rear view of electric control box



2 Outdoor Unit Main PCB

2.1 Ports

Figure 5-2.1: Outdoor unit main PCB ports¹

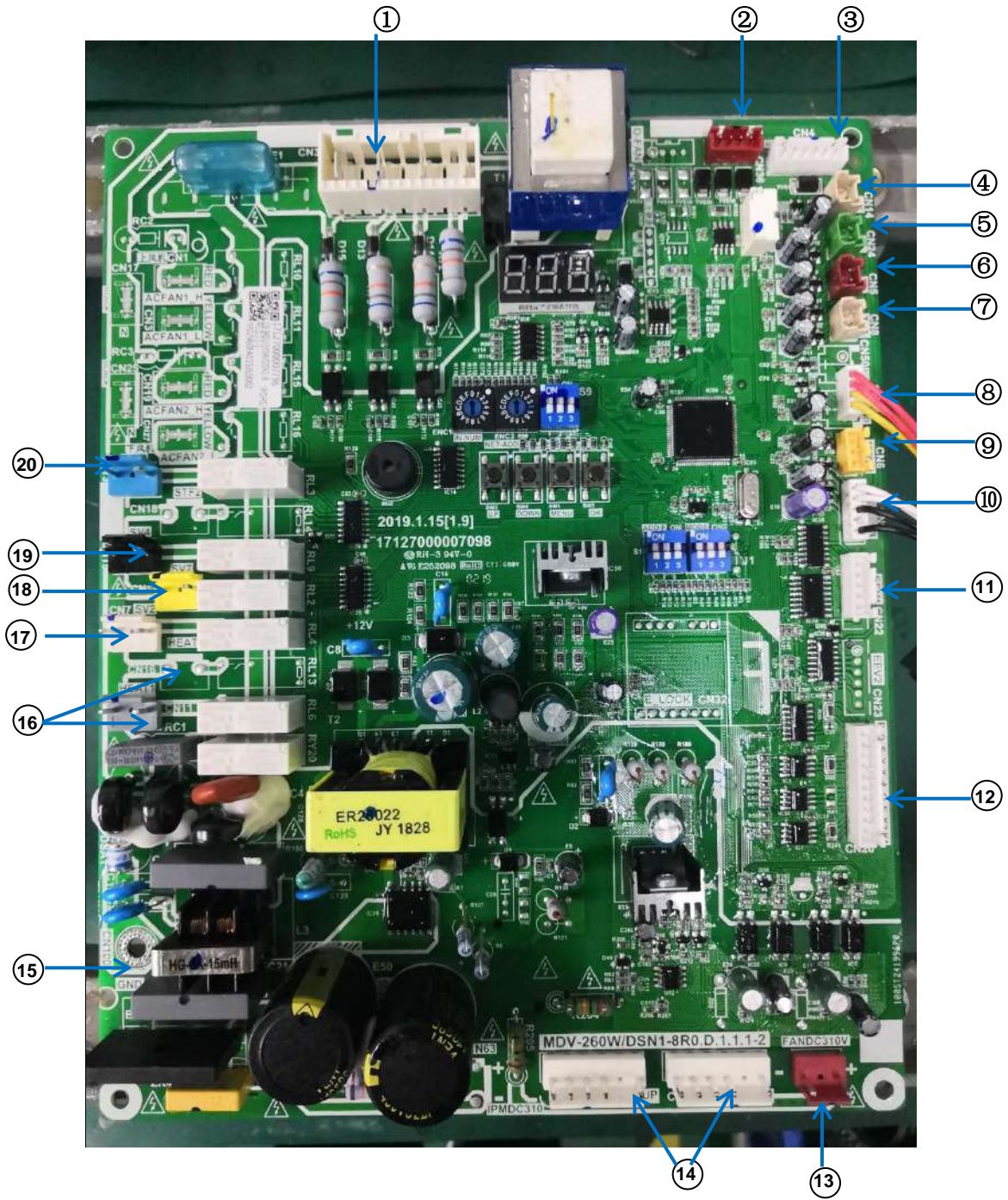

Notes:

1. Label descriptions are given in Table 5-2.1.

Table 5-2.1: Main PCB ports

| Label in Figure 5-2.1 | Port code | Content | Port voltage |
|-----------------------|----------------|---|---|
| 1 | CN30 | Power input of main board | 220V AC between A/B/C and N; 380V AC between A,B and C |
| 2 | CN36 | Inverter module connection | 0V or 5V DC |
| 3 | CN4 | Control port of filter board | 0V or 12V DC |
| 4 | CN14 | Heat sink temperature sensor (Tf) connection | 0-5V DC (varying) |
| 5 | CN24 | Refrigerant cooling pipe temperature sensor (TL) connection | 0-5V DC (varying) |
| 6 | CN5 | Discharge pipe temperature sensor (T5) connection | 0-5V DC (varying) |
| 7 | CN8 | Heat exchanger temperature sensor (T3A) connection (Reserved) | 0-5V DC (varying) |
| 8 | CN12 | High pressure sensor and low pressure sensor connections | 0-5V DC (varying) |
| 9 | CN6 | High pressure switch connection | 0V or 5V DC |
| 10 | CN9 | Heat exchanger temperature sensor outlet (T3) and ambient temperature sensor (T4) connections | 0-5V DC (varying) |
| 11 | CN22 | EEV drive port | 0V or 12V DC |
| 12 | CN20 | Communication port | 0-5V DC (varying) |
| 13 | CN53 | DC fan motor power supply connection | 310V DC |
| 14 | CN107 CN109 | DC fan motor control port | 0-310V DC (varying) |
| 15 | CN100 | Ground connection | |
| 16 | CN11 CN16 | Power supply to compressor crankcase heater | 220V AC |
| 17 | CN7 | Solenoid valve SV2 drive port | 220V AC |
| 18 | CN10 | Solenoid valve SV7 drive port | 220V AC |
| 19 | CN15 | Solenoid valve SV4 drive port | 220V AC |
| 20 | CN13 | Four-way valve drive ports | 220V AC |

2.2 Components

2.2.1 Layout

Figure 5-2.2: Outdoor unit main PCB components

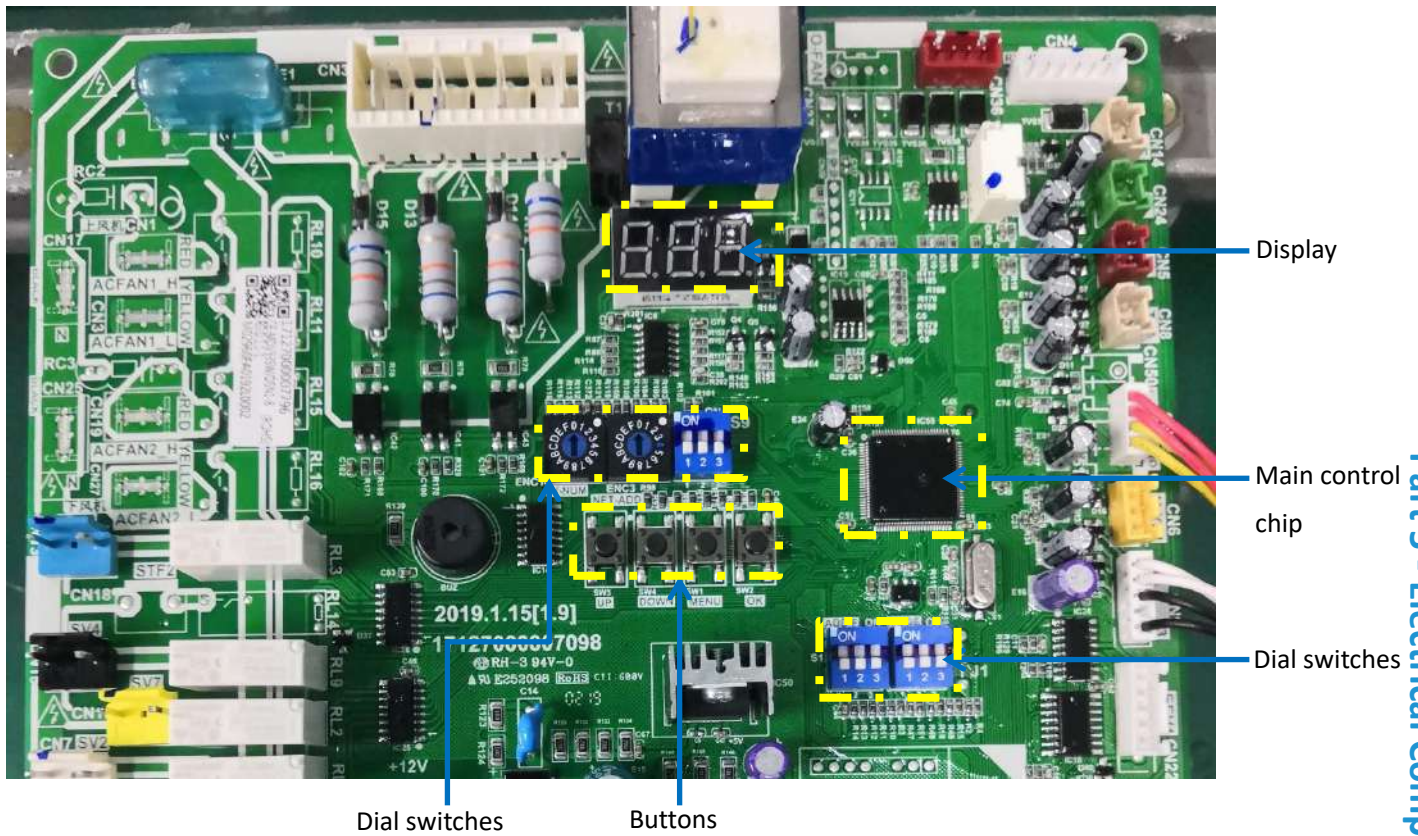

2.2.2 Function of buttons

Table 5-2.2: Function of buttons SW1 to SW4

| Button | Function |
|------------|---|
| SW3 (UP) | In menu mode: previous and next buttons for menu modes. |
| SW4 (DOWN) | Not in menu mode: previous and next buttons for system check information. |
| SW1 (MENU) | Enter / exit menu mode. |
| SW2 (OK) | Confirm to enter specified menu mode. |



2.2.3 Menu mode

1. Long press SW1 "MENU" button for 5 seconds to enter menu mode, and the digital display displays "n1";
2. Press SW3 / SW4 "UP / DOWN" button to select the first level menu "n1", "n2", "n3", "n4", "nb" or "nF";
3. Press SW2 "OK" button to enter specified first level menu, for example, enter "n3" mode;
4. Press SW3 / SW4 "UP / DOWN" button to select the second level menu from "n31" to "n34";
5. Press SW2 "OK" button to enter specified second level menu, for example, enter "n32" mode;

Menu mode selection flowchart:

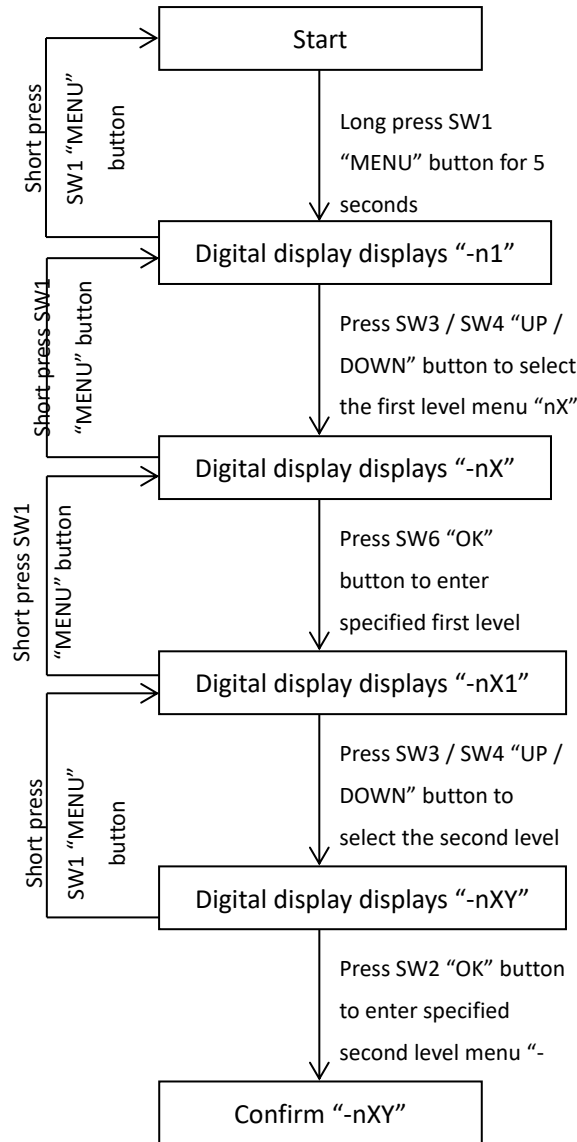

Menu mode function:
Table 5-2.3: Menu mode function

| Digital display content | Menu mode | Remarks |
|-------------------------|------------------------------|--|
| n14 | Force cooling mode | All indoor units running in cooling mode |
| n16 | Maintenance mode | The system does not check the indoor units' number. |
| n27 | Vacuum mode | It is only used in maintenance process. The digital display displays "R01", and all solenoid valves are opened and EXVs are positioned to 480 steps. |
| n31 | History error codes | Displays recent 10 history error codes |
| n32 | Cleaning history error codes | |
| n34 | Factory reset | |
| nb3 | Exit auto power save mode | |
| nb4 | Enter auto power save mode | |
| nF1 | Adjust T2 | Only 40 to 50 could be selected (default value is 44). |
| nF2 | Adjust T2B | Only 5 to 15 could be selected (default value is 8). |

How to exit specified menu mode:
Table 5-2.4: Exit specified menu mode method:

| Menu mode | Manual exit method | Automatic exit method |
|----------------------|--|--------------------------|
| Debug mode 1 (2) | Long press SW2 "OK" button when the digital display is not in menu selection state | After running 60 minutes |
| Maintenance mode | / | After running 60 minutes |
| Vacuum mode | Long press SW2 "OK" button when the digital display is not in menu selection state | After running 8 hours |
| Auto power save mode | Select "nb3" | / |

In the non-menu selection state, long press SW2 "OK" button for 3s, it will automatically exit all test modes.

2.2.4 System check button

Before pressing UP or DOWN button, make sure that the system has been operating steadily for more than one hour. On pressing UP or DOWN button, the parameters listed in Table 5-2.5 will be displayed in sequence.

Table 5-2.5: System check

| DSP content | Parameters displayed on DSP | Remarks |
|-------------|---|---|
| 1.-- | Unit capacity (Hp) | Actual value = value displayed |
| 2.-- | Setting number of indoor units | |
| 3.-- | Operating mode | Refer to Note 1 |
| 4.-- | Fan speed index | Refer to Note 2 |
| 5.-- | Total capacity of outdoor unit | |
| 6.-- | Total capacity requirement of indoor units | |
| 7.-- | Main heat exchanger pipe (T3) temperature (°C) | Actual value = value displayed |
| 8.-- | Outdoor ambient (T4) temperature (°C) | Actual value = value displayed |
| 9.-- | Inverter compressor discharge temperature (°C) | Actual value = value displayed |
| 10.-- | Invert module (TF) temperature (°C) | Actual value = value displayed |
| 11.-- | Refrigerant cooling pipe (TL) temperature (°C) | Actual value = value displayed |
| 12.-- | Compressor discharge pressure (MPa) | Actual value = value displayed × 0.1 |
| 13.-- | Discharge superheat degree (°C) | Actual value = value displayed |
| 14.-- | EXVA position | Actual value = value displayed × 8 |
| 15.-- | Actual current (A) | Actual value = value displayed |
| 16.-- | Inverter compressor current (A) | Actual value = value displayed |
| 17.-- | Actual voltage (V) | Actual value = value displayed |
| 18.-- | DC bus voltage (V) | Actual value = value displayed |
| 19.-- | Indoor heat exchanger pipe (T2/T2B) temperature (°C) | Actual value = value displayed |
| 20.-- | Priority mode | Refer to Note 3 |
| 21.-- | Number of indoor units currently in communication with outdoor unit | Actual value = value displayed |
| 22.-- | Number of indoor units currently operating | Actual value = value displayed |
| 23.-- | Most recent error or protection code | "nn" is displayed if no error or protection events have occurred since start-up |
| 24.-- | Software version | |
| 25.-- | -- | End |

Notes:

1. Operating mode:
 - 0: off; 2: cooling; 3: heating; 4: forced cooling.
2. The fan speed index is related to the fan speed in rpm and can take any integer value in the range 1 (slowest) to 11 (fastest).
3. Priority mode:
 - 0: heating priority; 1: cooling priority; 2: first ON priority; 3: heating only; 4: cooling only; 5: test mode 1; 6: test mode 2
4. Inverter compressor discharge temperature:
 - (10.):100°C-109°C; (11.):110°C-119°C

2.2.5 Digital display output

Table 5-2.6: Digital display output in different operating states

| Outdoor unit state | Parameters displayed on DSP |  |
|---------------------|--|---|
| Standby | The number of indoor units in communication with the outdoor unit | |
| Normal operation | Frequency limitation code ¹ and running speed of the compressor in rotations per second | |
| Error or protection | Error or protection code | |
| In menu mode | Refer to Table 5-2.3 | |
| System check | Refer to Table 5-2.5 | |

Notes:

1. Frequency limitation code:
 - P: Compressor discharge temperature frequency limitation; C: Pressure frequency limitation; A: Ambient temperature frequency limitation; F: Heat sink temperature frequency limitation; U: Voltage frequency limitation; H: Current frequency limitation; d: DC voltage frequency limitation.

3 Compressor Inverter Module and Filter Board

3.1 Inverter module ports

Figure 5-3.1: Outdoor unit inverter module ports¹

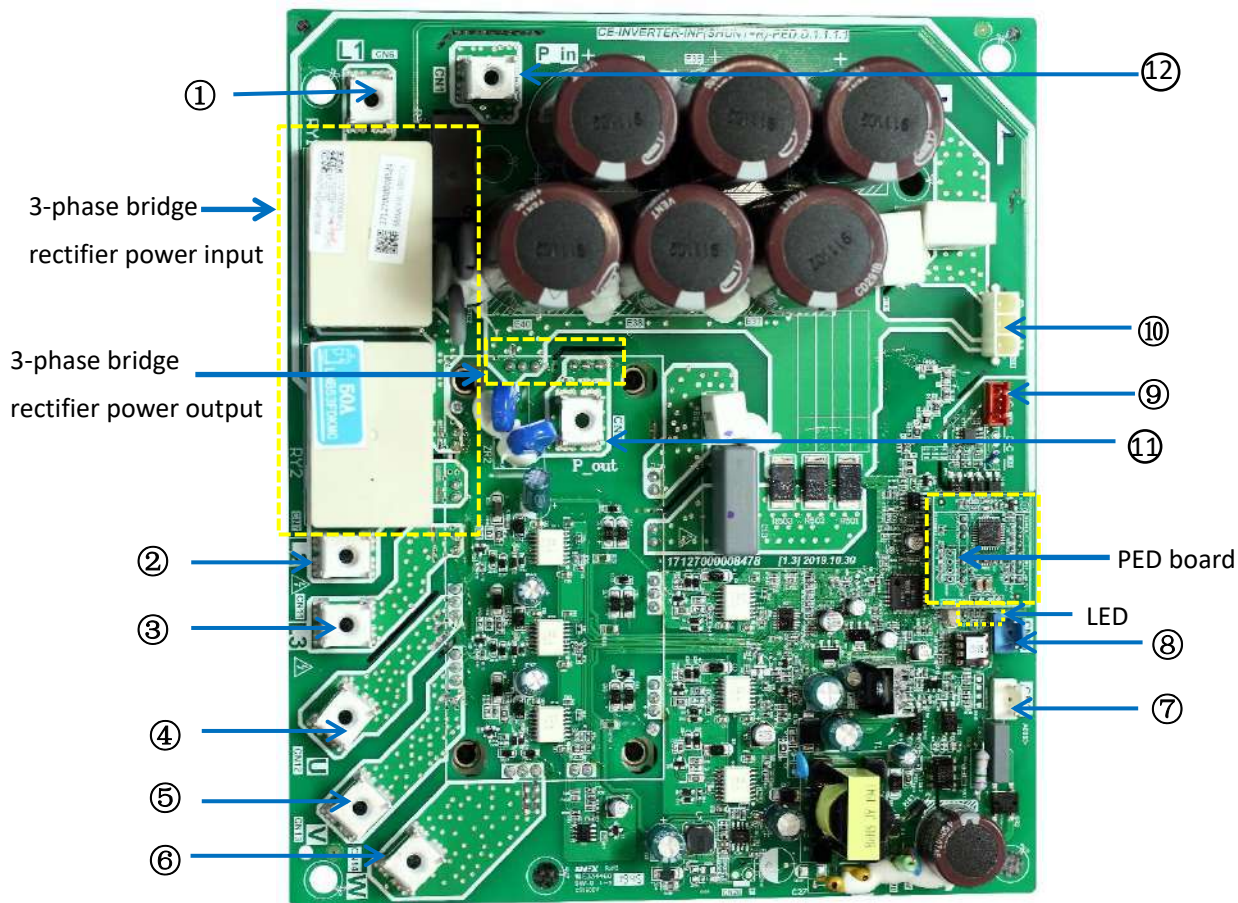

Notes:

1. Label descriptions are given in Table 5-3.1.

Table 5-3.1: Inverter module ports

| Label in Figure 5-2.1 | Port code | Content | Port voltage |
|-----------------------|-----------|---|--|
| 1 | CN6 | Power input L1 of inverter module | 380V AC |
| 2 | CN7 | Power input L2 of inverter module | 380V AC |
| 3 | CN11 | Power input L3 of inverter module | 380V AC |
| 4 | CN12 | Power output U of inverter module to compressor | Above 156V DC (varying according to frequency) |
| 5 | CN13 | Power output V of inverter module to compressor | Above 156V DC (varying according to frequency) |
| 6 | CN14 | Power output W of inverter module to compressor | Above 156V DC (varying according to frequency) |
| 7 | CN2 | DC power supply input | 310V DC |
| 8 | CN23 | High pressure switch connection | +12V DC |
| 9 | CN8 | Main PCB connection | 0-5V DC (varying) |
| 10 | CN38 | Reserved | |
| 11 | CN5 | DC bus output connect to reactor | 350-640V DC (varying) |
| 12 | CN1 | DC bus input connect to reactor | 350-640V DC (varying) |

LED indicators LED1 and LED2

Table 5-3.2: LED indicators LED1 and LED2

| Indicator | LED indicator function and status | |
|-----------|---|--|
| LED 1 | Inverter module operating indicator. Continuously on if the compressor is running normally and flashing if an inverter module error has occurred ¹ . | |
| LED 2 | Inverter module error indicator. Continuously on if an inverter module error has occurred ¹ . | |

Note:

1. If an inverter module error occurs, refer to Part 6, "H4 Troubleshooting". The error code is displayed on the digital display.

3.2 Filter board ports

Figure 5-3.2: Outdoor unit filter board ports¹

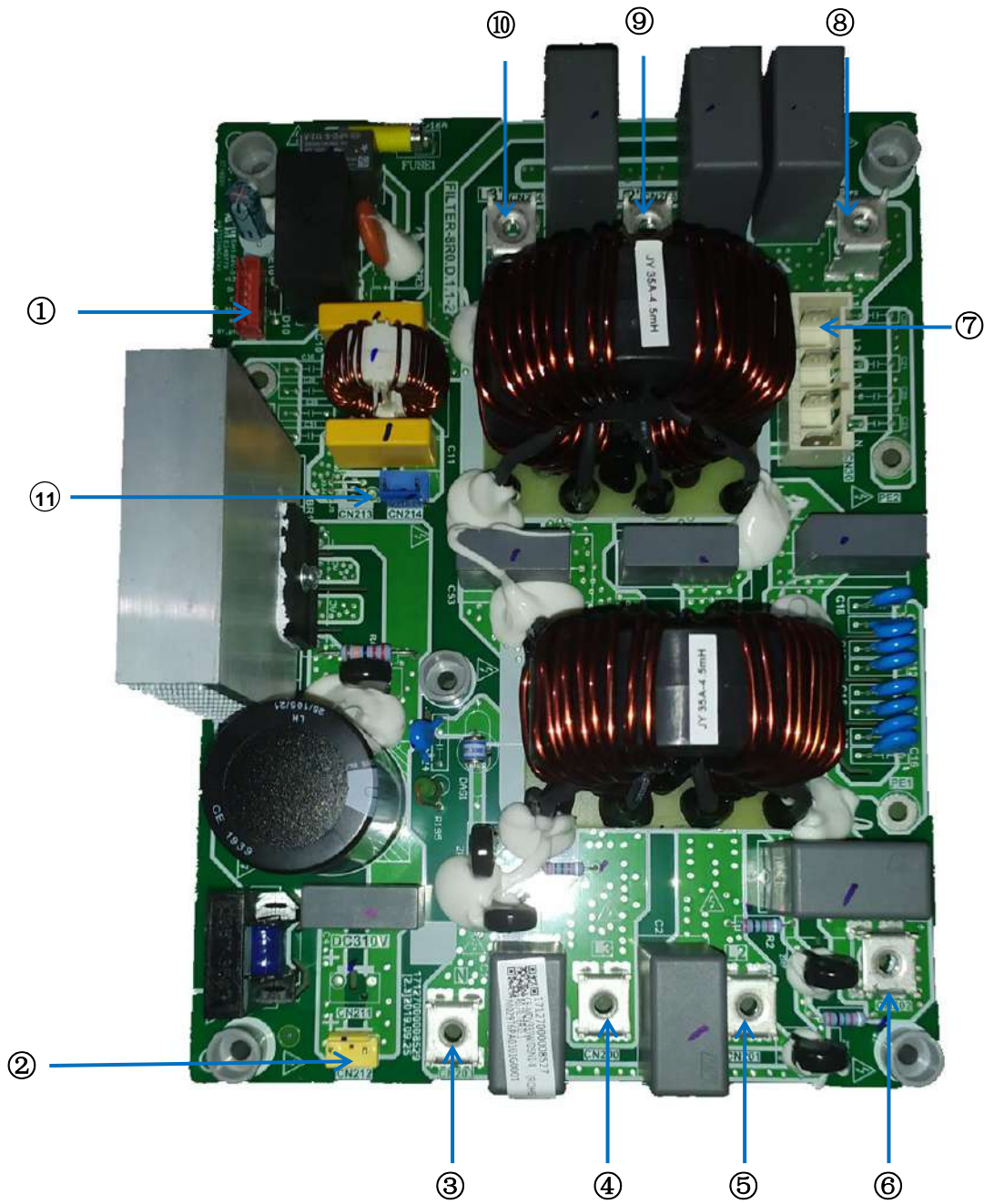

Notes:

1. Label descriptions are given in Table 5-3.3.

Table 5-3.3: Filter board ports

| Label in Figure 5-3.2 | Port code | Content | Port voltage |
|-----------------------|-----------|--|---|
| 1 | CN8 | Control port of filter board | 12V DC |
| 2 | CN212 | Power supply to DC fan motor (CN212) of filter board | 310V DC |
| 3 | CN203 | Power input N of filter board | 220V AC between L1/L2/L3 and N; 380V AC between L1,L2 and L3 |
| 4 | CN200 | Power input L1 of filter board | 220V AC between L1/L2/L3 and N; 380V AC between L1,L2 and L3 |
| 5 | CN201 | Power input L2 of filter board | 220V AC between L1/L2/L3 and N; 380V AC between L1,L2 and L3 |
| 6 | CN202 | Power input L3 of filter board | 220V AC between L1/L2/L3 and N; 380V AC between L1,L2 and L3 |
| 7 | CN30 | Power supply output to main PCB | 220V AC between L1/L2/L3 and N; 380V AC between L1,L2 and L3 |
| 8 | CN206 | Power output L1 of filter board | 220V AC between L1/L2/L3 and N; 380V AC between L1,L2 and L3 |
| 9 | CN205 | Power output L2 of filter board | 220V AC between L1/L2/L3 and N; 380V AC between L1,L2 and L3 |
| 10 | CN204 | Power output L3 of filter board | 220V AC between L1/L2/L3 and N; 380V AC between L1,L2 and L3 |
| 11 | CN214 | Power supply to inverter board (CN214) of filter board | 220V AC |

Quantum Series (AU)



4 Wiring Diagrams

Figure 5-4.1: Wiring diagram

| CODE | NAME |
|-------------|--|
| ACFAN1/2 | AC fan motor |
| COMP | Inverter compressor |
| EEV1/2 | Electric expansion valve |
| FAN UP/DOWN | DC fan motor |
| HEAT1/HEAT2 | Crankcase heating |
| H PRO/L PRO | High/Low pressure switch or shoring stub |
| H-YL1 | High pressure sensor |
| XT1 | Big 4-phase terminal |
| CT1 | AC current transformer |
| RA | Reactor |
| STF1/STF2 | 4-way valve |
| SV2/SV4/SV7 | Solenoid valve |
| T3/T3A | Piping temperature sensor |
| T4 | Outdoor ambient temperature sensor |
| T5 | Inverter compressor discharge temperature sensor |
| TL | Cooling refrigerant radiator pipe temperature sensor |
| TF | Inverter-module heatsink temperature sensor |

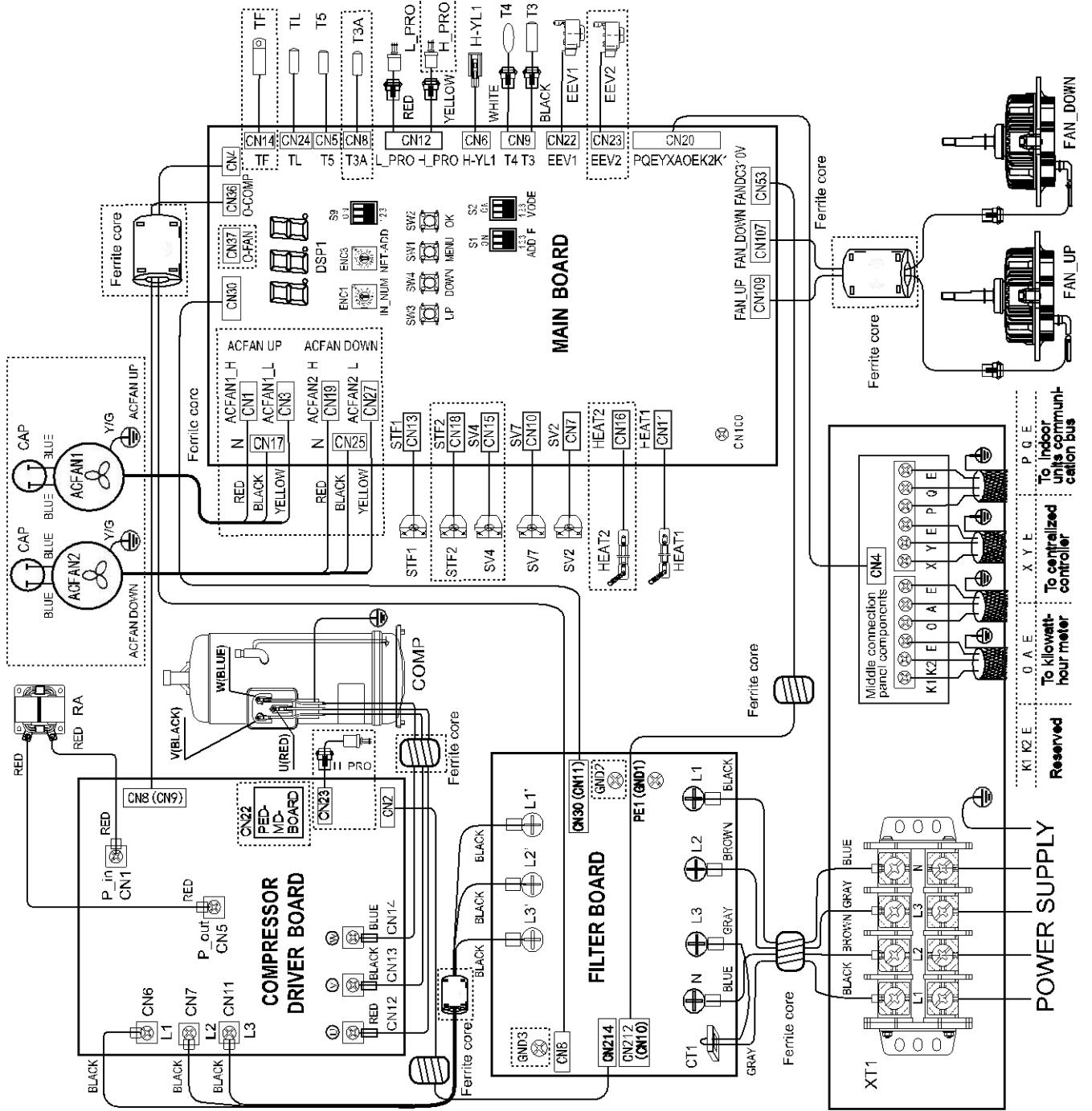

Part 6

Outdoor Diagnosis and Troubleshooting

| | | |
|---|--------------------------|-----|
| 1 | Error Code Table | 62 |
| 2 | Troubleshooting | 63 |
| 3 | Appendix to Part 6 | 115 |

1 Error Code Table

Table 6-1.1: Error code table

| Error code ¹ | Content | Remarks | Manual re-start required ¹ |
|-------------------------|---|-----------------------------------|---------------------------------------|
| E1 | Phase sequence error | Displayed on the outdoor unit PCB | Yes |
| E2 | Communication error between indoor and outdoor units | Displayed on the outdoor unit PCB | No |
| E4 | Outdoor heat exchanger temperature sensor (T3) error or outdoor ambient temperature sensor (T4) error | Displayed on the outdoor unit PCB | No |
| E5 | Abnormal power supply voltage | Displayed on the outdoor unit PCB | No |
| E6 | DC fan motor error | Displayed on the outdoor unit PCB | No |
| Eb | E6 error appears 6 times in 1 hour | Displayed on the outdoor unit PCB | Yes |
| E7 | Outdoor compressor discharge temperature sensor (T5) error | Displayed on the outdoor unit PCB | No |
| EH | Outdoor refrigerant cooling pipe temperature sensor (TL) error | Displayed on the outdoor unit PCB | No |
| F1 | DC bus voltage error | Displayed on the outdoor unit PCB | No |
| H0 | Communication error between main control chip and inverter driver chip | Displayed on the outdoor unit PCB | No |
| H4 | Inverter module protection, P6 protection appears three times in 30 minutes | Displayed on the outdoor unit PCB | Yes |
| H5 | P2 protection appears three times in 60 minutes | Displayed on the outdoor unit PCB | Yes |
| H7 | Number of indoor units detected by outdoor unit not same as number set on main PCB | Displayed on the outdoor unit PCB | No |
| H8 | High pressure sensor error | Displayed on the outdoor unit PCB | No |
| bL | High pressure switch protection on compressor inverter board | Displayed on the outdoor unit PCB | No |
| bH | PED board error | Displayed on the outdoor unit PCB | No |
| P1 | Discharge pipe high pressure protection | Displayed on the outdoor unit PCB | No |
| P2 | Suction pipe low pressure protection | Displayed on the outdoor unit PCB | No |
| P3 | Compressor current protection | Displayed on the outdoor unit PCB | No |
| P4 | Discharge temperature protection | Displayed on the outdoor unit PCB | No |
| P5 | Outdoor heat exchanger temperature protection | Displayed on the outdoor unit PCB | No |
| P8 | Typhoon protection | Displayed on the outdoor unit PCB | No |
| PL | Heat sink high temperature protection | Displayed on the outdoor unit PCB | No |
| L0 | Inverter module protection | Displayed on the outdoor unit PCB | Yes |
| L1 | DC bus low voltage protection | Displayed on the outdoor unit PCB | Yes |
| L2 | DC bus high voltage Heat sink temperature sensor protection | Displayed on the outdoor unit PCB | Yes |
| L4 | MCE error | Displayed on the outdoor unit PCB | Yes |
| L5 | Zero speed protection | Displayed on the outdoor unit PCB | Yes |
| L7 | Phase sequence error | Displayed on the outdoor unit PCB | Yes |
| L8 | Compressor frequency variation greater than 15Hz within one second protection | Displayed on the outdoor unit PCB | Yes |
| L9 | Actual compressor frequency differs from target frequency by more than 15Hz protection | Displayed on the outdoor unit PCB | Yes |

Notes:

1. For some error codes, a manual restart is required before the system can resume operation.

2 Troubleshooting

2.1 Warning

Warning



- All electrical work must be carried out by competent and suitably qualified, certified and accredited professionals and in accordance with all applicable legislation (all national, local and other laws, standards, codes, rules, regulations and other legislation that apply in a given situation).
- Power-off the outdoor units before connecting or disconnecting any connections or wiring, otherwise electric shock (which can cause physical injury or death) may occur or damage to components may occur.

2.2 E1: Phase sequence error

2.2.1 Digital display output



2.2.2 Description

- Phase sequence error.
- The system stops running.
- Error code is displayed on the outdoor unit PCB.

2.2.3 Trigger / recover condition

- Trigger condition: Wrong phase connection for 1.6s or phase missing for 48s.
- Recover condition: Correct phase connection.
- Reset method: Manually restart.

2.2.4 Possible causes

- Power supply phases not connected in correct sequence.
- Power supply terminals loose.
- Power supply abnormal.
- Main PCB damaged.

2.2.5 Procedure

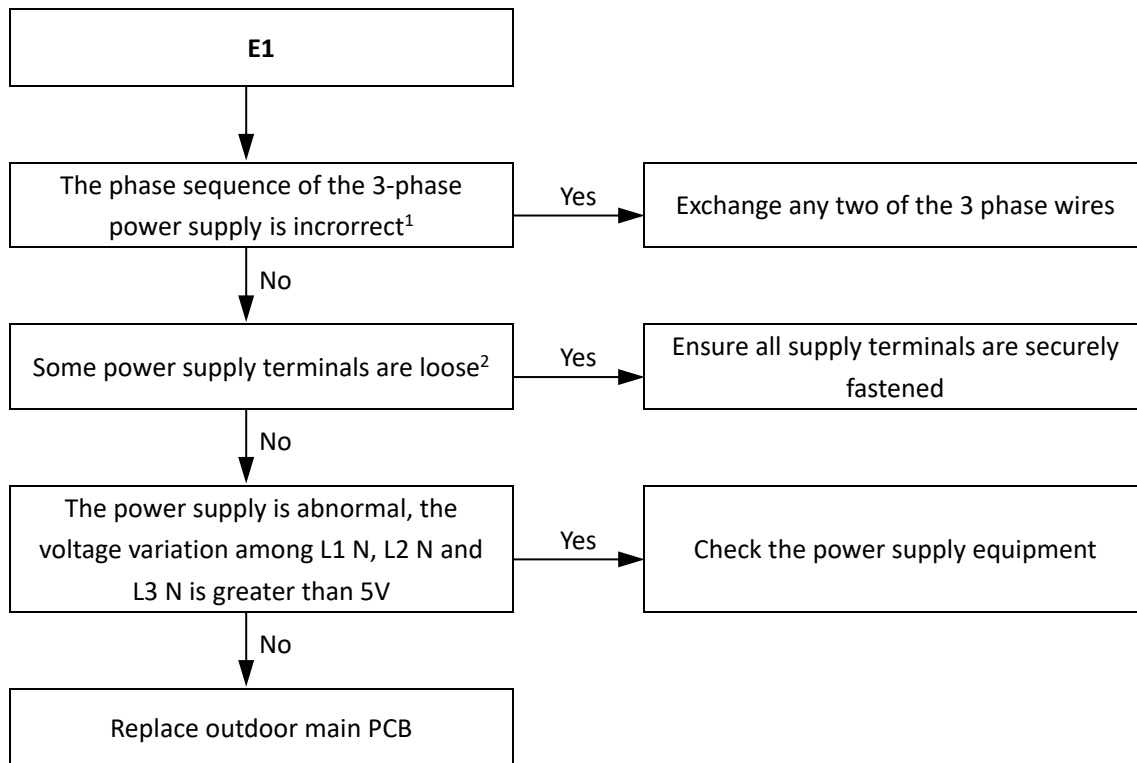

Notes:

1. The L1, L2, L3 terminals of the 3-phase power supply should match compressor phase sequence requirements. If the phase sequence is inverted, the compressor will operate inversely.
2. Loose power supply terminals can cause the compressor to operate abnormally and compressor current to be very large.

2.3 E2: Communication error between indoor and outdoor unit

2.3.1 Digital display output



2.3.2 Description

- Communication error between indoor and outdoor unit.
- The system stops running.
- Error code is displayed on the outdoor unit PCB.

2.3.3 Trigger / recover condition

- Trigger condition: Indoor units and the outdoor unit cannot communicate for 2 minutes after the system is powered on for 20 minutes.
- Recover condition: Communication goes back to normal.
- Reset method: Resume automatically.

2.3.4 Possible causes

- Communication wires between indoor and outdoor units not connected properly.
- Indoor unit power supply abnormal.
- Loosened wiring within electric control box.
- Interference from high voltage wires or other sources of electromagnetic radiation.
- Communication wire too long.
- Damaged main PCB or electric control box communication terminals block.

2.3.5 Procedure

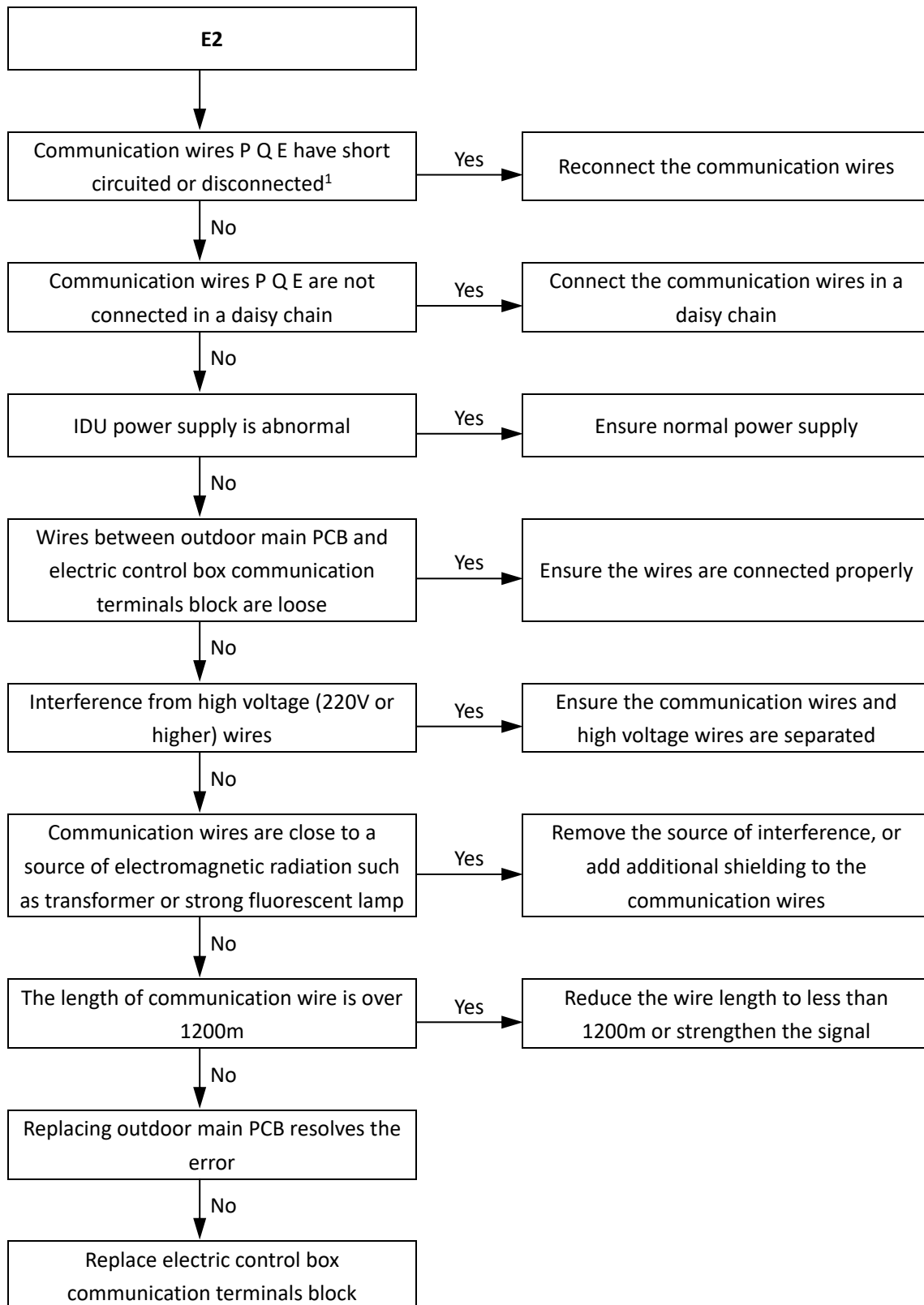

Notes:

1. Measure the resistance among P, Q and E. The normal resistance between P and Q is 120Ω, between P and E is infinite, between Q and E is infinite.

2.4 E4: Temperature sensor (T3/T4) error

2.4.1 Digital display output



2.4.2 Description

- Outdoor heat exchanger temperature sensor (T3) error or outdoor ambient temperature sensor (T4) error.
- The system stops running.
- Error code is displayed on the outdoor unit PCB.

2.4.3 Trigger / recover condition

- Trigger condition: The main control board cannot receive the feedback signal of temperature sensor T3 or T4.
- Recover condition: The main control board can receive the feedback signal of temperature sensor T3 or T4.
- Reset method: Resume automatically.

2.4.4 Possible causes

- Temperature sensor not connected properly or has malfunctioned.
- Damaged main PCB.

2.4.5 Procedure

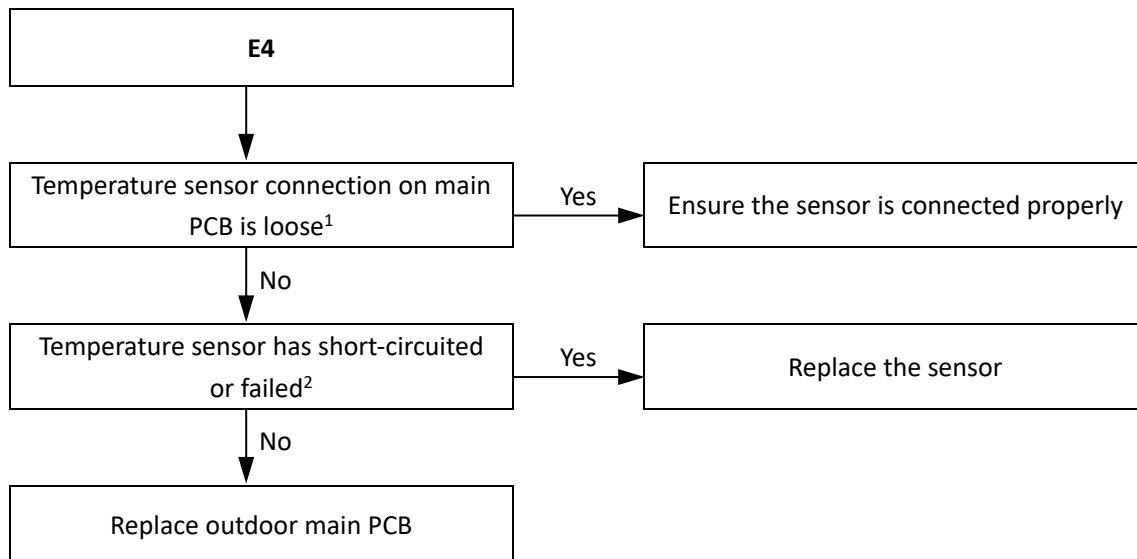

Notes:

1. Outdoor ambient temperature sensor (T4) and heat exchanger temperature sensor (T3) connection is port CN9 on the main PCB (labeled 10 in Figure 5-2.1 in Part 5, 2.1 "Ports").
2. Measure sensor resistance. If the resistance is too low, the sensor has short-circuited. If the resistance is not consistent with the sensor's resistance characteristics table, the sensor has failed. Refer to Table 6-3.1 in Part 6, 3.1 "Temperature Sensor Resistance Characteristics".

Quantum Series (AU)

2.5 E5: Abnormal power supply voltage

2.5.1 Digital display output



2.5.2 Description

- Abnormal power supply voltage.
- The system stops running.
- Error code is displayed on the outdoor unit PCB.

2.5.3 Trigger / recover condition

- Trigger condition: Outdoor unit power supply phase voltage < 172V.
- Recover condition: Outdoor unit power supply phase voltage is > 265V.
- Reset method: Resume automatically.

2.5.4 Possible causes

- Outdoor unit power supply voltage is abnormal or a phase is missing.
- Loosened wiring within electric control box.
- High voltage circuit error.
- Main PCB damaged.

2.5.5 Procedure

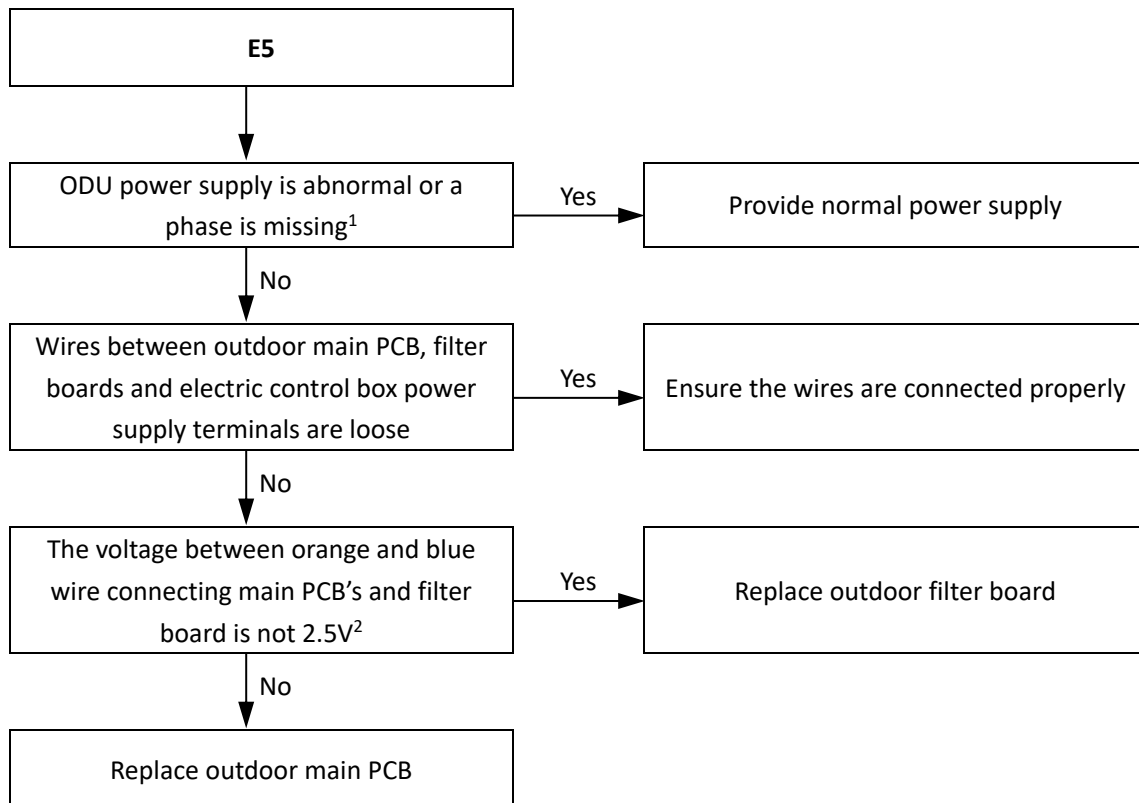

Notes:

1. The normal voltage between L1 and N, L2 and N, and L3 and N is 172-265V.
2. Control port of filter board is CN4 on the main PCB (labeled 3 in Figure 5-2.1 in Part 5, 2.1 "Ports").

Quantum Series (AU)



2.6 E6, Eb: DC fan motor error

2.6.1 Digital display output



2.6.2 Description

- DC fan motor error.
- The system stops running.
- Error code is displayed on the outdoor unit PCB.

2.6.3 Trigger / recover condition

- Trigger condition:
 - For E6 protection: Actual fan speed is < 120 rps more than 20S or the actual fan speed differs from target speed by more 200rps for more than 3 minutes.
 - For Eb protection: E6 protection appears six times in 60 minutes.
- Recover condition: Actual fan speed is > 120 rps and the actual fan speed differs from target speed less than 200rps.
- Reset method: Resume automatically.
 - For E6 protection: Resume automatically.
 - For Eb protection: Manually restart.

2.6.4 Possible causes

- Loosened wiring within electric control box.
- DC fan motor damaged.
- Filter board damaged.
- Main PCB damaged.

2.6.5 Procedure

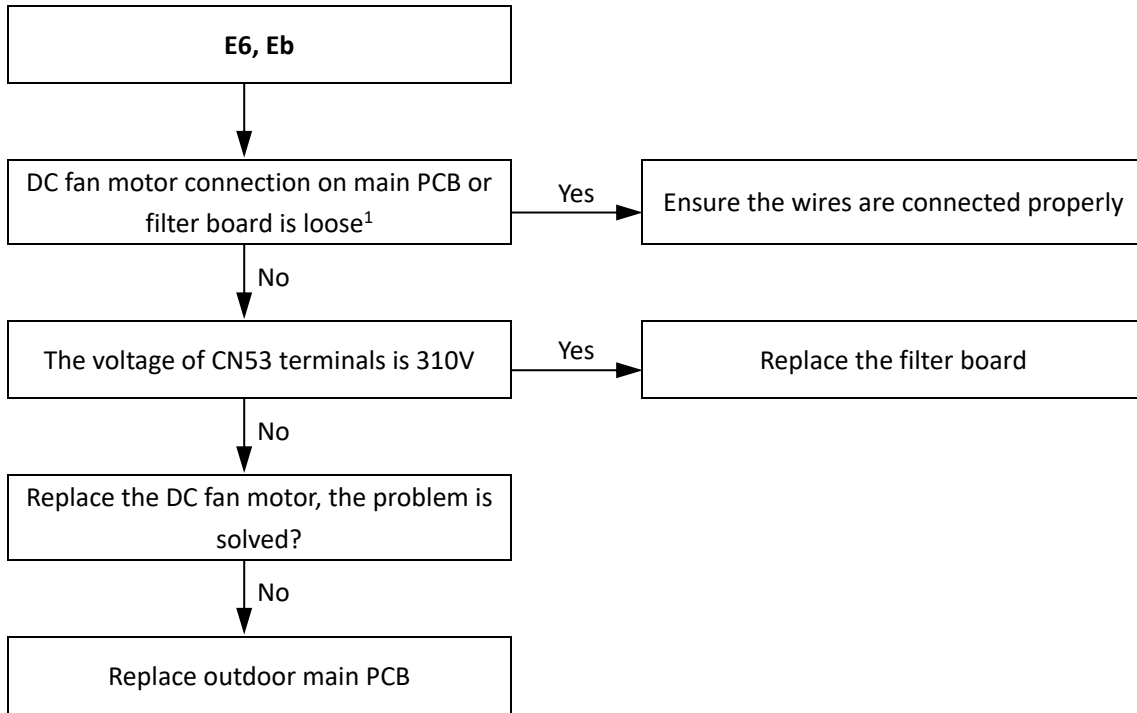

Notes:

- DC fan motor connections on main PCB are ports CN107, CN109 (labeled 14 in Figure 5-2.1 in Part 5, 2.1 "Ports") and CN53 (labeled 13 in Figure 5-2.1 in Part 5, 2.1 "Ports"). DC fan motor connection on filter board is ports CN212 (labeled 2 in Figure 5-3.2 in Part 5, 3.2 "Filter Board Ports").

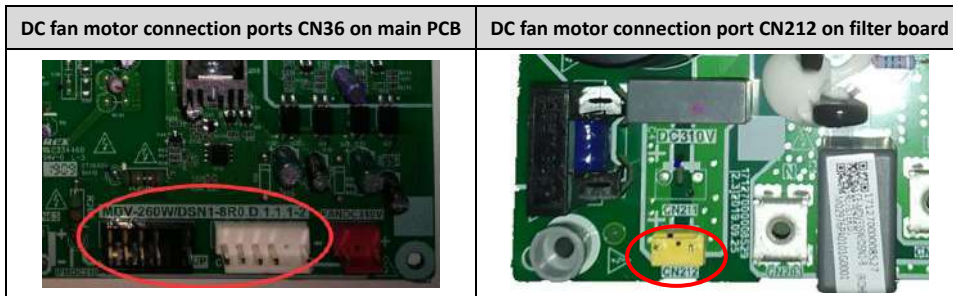

Quantum Series (AU)

2.7 E7: Temperature sensor (T5) error

2.7.1 Digital display output



2.7.2 Description

- A compressor discharge pipe temperature sensor (T5) error.
- The system stops running.
- Error code is displayed on the outdoor unit PCB.

2.7.3 Trigger / recover condition

- Trigger condition: Discharge temperature < 15°C for 2 minutes after compressor startup for 10 minutes.
- Recover condition: Discharge temperature go back to normal.
- Reset method: Manually restart.

2.7.4 Possible causes

- Temperature sensor not connected properly or has malfunctioned.
- Damaged main PCB.

2.7.5 Procedure

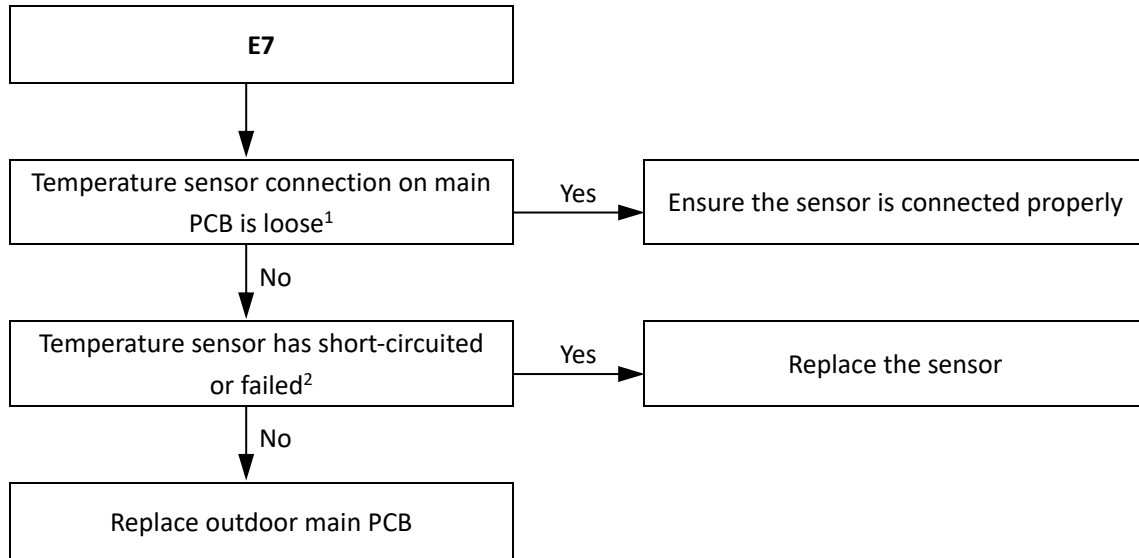

Notes:

1. Compressor discharge pipe temperature sensor connection is port CN5 on the main PCB (labeled 6 in Figure 5-2.1 in Part 5, 2.1 "Ports").
2. Measure sensor resistance. If the resistance is too low, the sensor has short-circuited. If the resistance is not consistent with the sensor's resistance characteristics table, the sensor has failed. Refer to Table 6-3.2 in Part 6, 3.1 "Temperature Sensor Resistance Characteristics".

Quantum Series (AU)

2.8 EH: Outdoor refrigerant cooling pipe temperature sensor (TL) error

2.8.1 Digital display output



2.8.2 Description

- An outdoor refrigerant cooling pipe temperature sensor (TL) error.
- The system stops running.
- Error code is displayed on the outdoor unit PCB.

2.8.3 Trigger / recover condition

- Trigger condition: The main control board cannot receive the feedback signal of temperature sensor TL.
- Recover condition: The main control board can receive the feedback signal of temperature sensor TL.
- Reset method: Manually restart.

2.8.4 Possible causes

- Temperature sensor not connected properly or has malfunctioned.
- Damaged main PCB.

2.8.5 Procedure

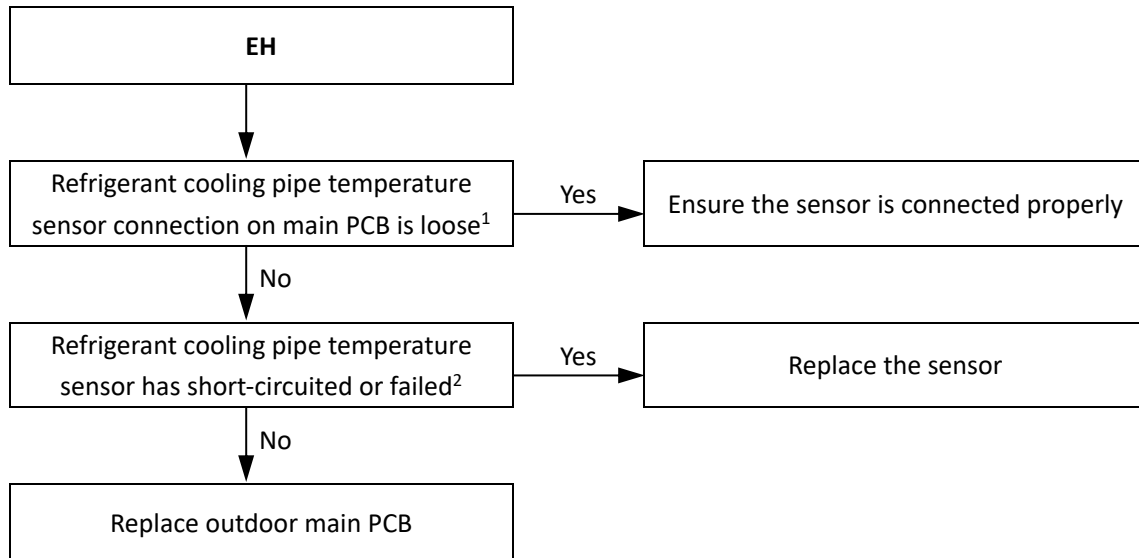

Notes:

1. Outdoor refrigerant cooling pipe temperature sensor connection is port CN24 on the main PCB (labeled 5 in Figure 5-2.1 in Part 5, 2.1 "Ports").
2. Measure sensor resistance. If the resistance is too low, the sensor has short-circuited. If the resistance is not consistent with the sensor's resistance characteristics table, the sensor has failed. Refer to Table 6-3.1 in Part 6, 3.1 "Temperature Sensor Resistance Characteristics".

Quantum Series (AU)

2.9 F1: DC bus voltage error

2.9.1 Digital display output



2.9.2 Description

- F1 indicates compressor DC bus voltage error.
- The system stops running.
- Error code is displayed on the unit with the error.

2.9.3 Trigger / recover condition

- Trigger condition: DC bus voltage < 200V continuously for 5 seconds.
- Recover condition: DC bus voltage goes back to normal.
- Reset method: Restart automatically.

2.9.4 Possible causes

- Loosened wiring of the compressor inverter module.
- Incorrect wiring of the reactor and DC bus wire.
- Abnormal power supply.
- Inverter module damaged.

2.9.5 Procedure

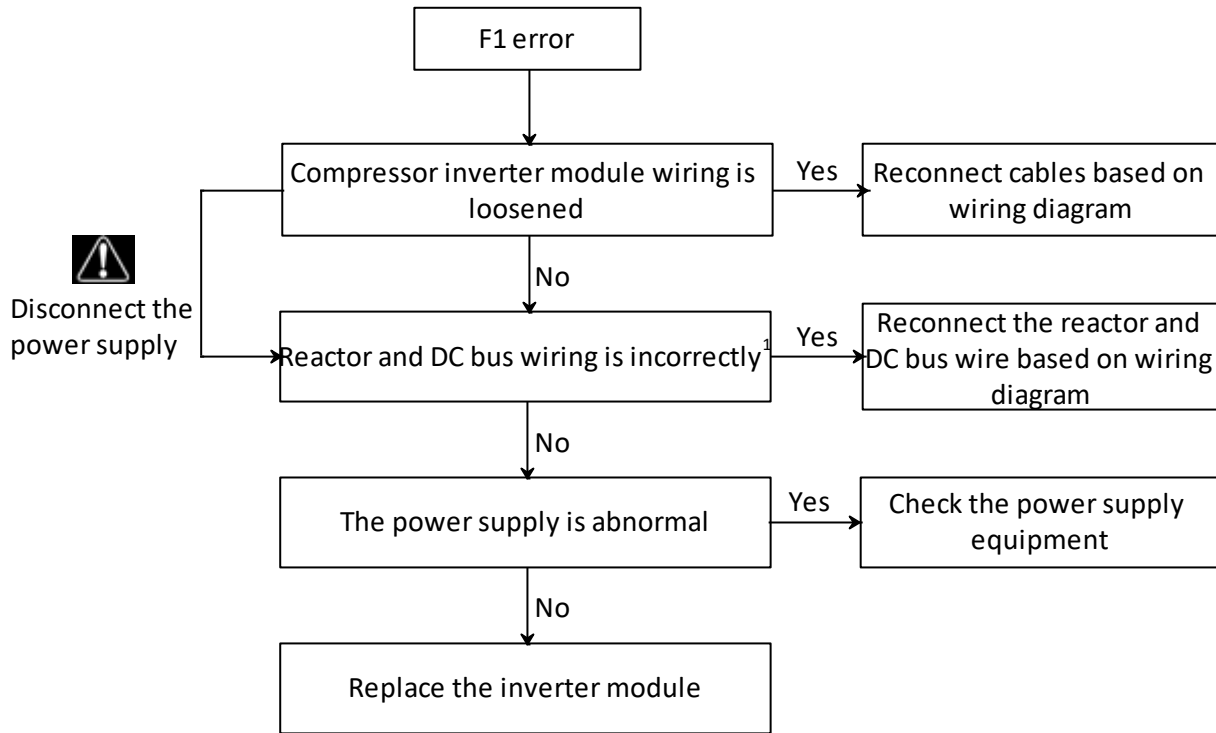

Note:

1. The normal DC voltage between terminals P and N on inverter module should be 450-650V.

Figure 6-2.1: P and N terminals on Inverter module



2.10 H0: Communication error

2.10.1 Digital display output



2.10.2 Description

- H0 indicates a communication error between the main control chip and the compressor inverter driver chip.
- The system stops running.
- Error code is displayed on the outdoor unit PCB.

2.10.3 Trigger / recover condition

- Trigger condition: Main control chip and inverter driver chip cannot communication for 2 minutes.
- Recover condition: Communication go back to normal.
- Reset method: Resume automatically.

2.10.4 Possible causes

- Loosened communication wiring from the main PCB to the inverter module.
- Main PCB damaged.
- Compressor inverter module damaged.

2.10.5 Procedure

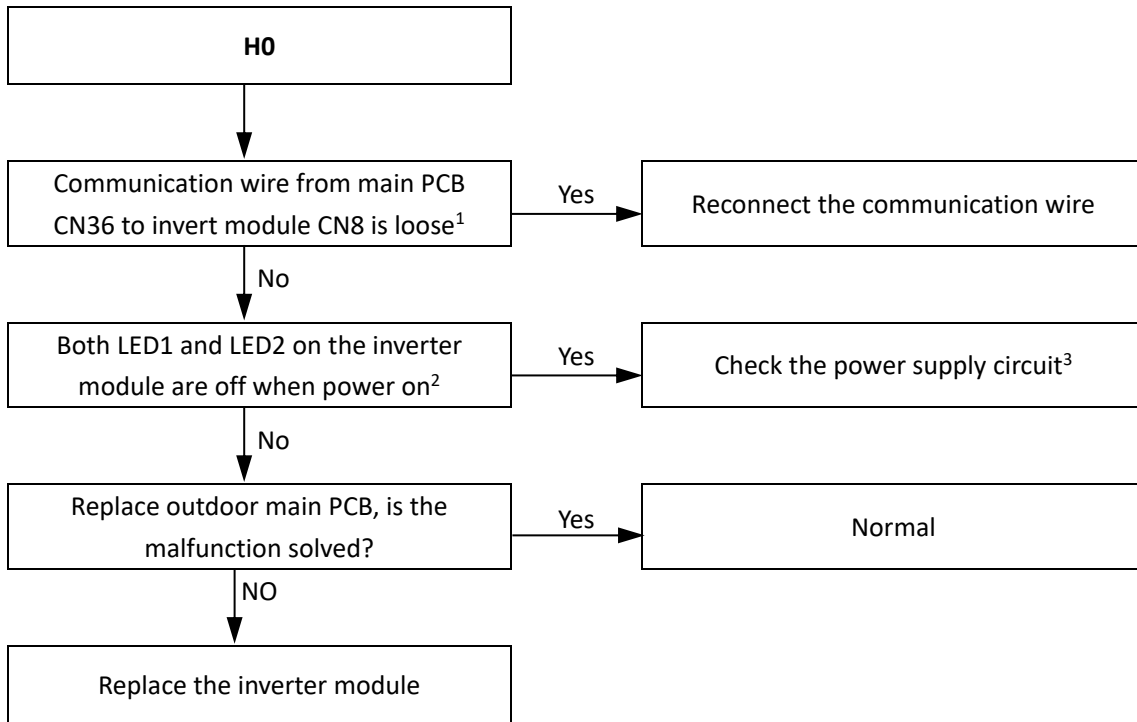

Notes:

1. Communication wire from outdoor main PCB CN36 to inverter module CN8.

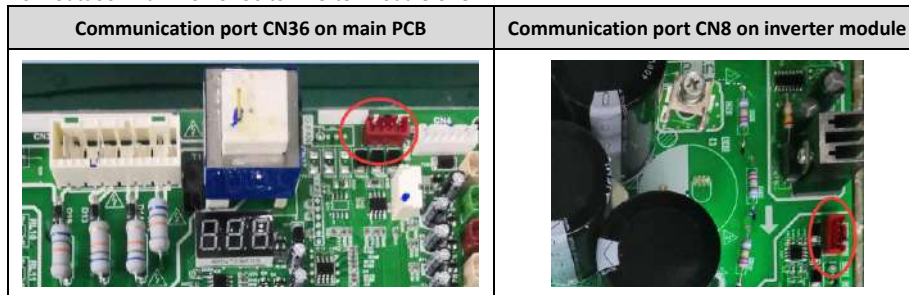

2. LED1/2 on inverter module



3. Check the power supply for the compressor inverter module, port CN211 on filter board, the normal voltage should be DC310V; Check the single phase bridge and fuse on filter board; check the connection cable from ODU main PCB port CN4 to filter board port CN8 which is 12V DC power control port.

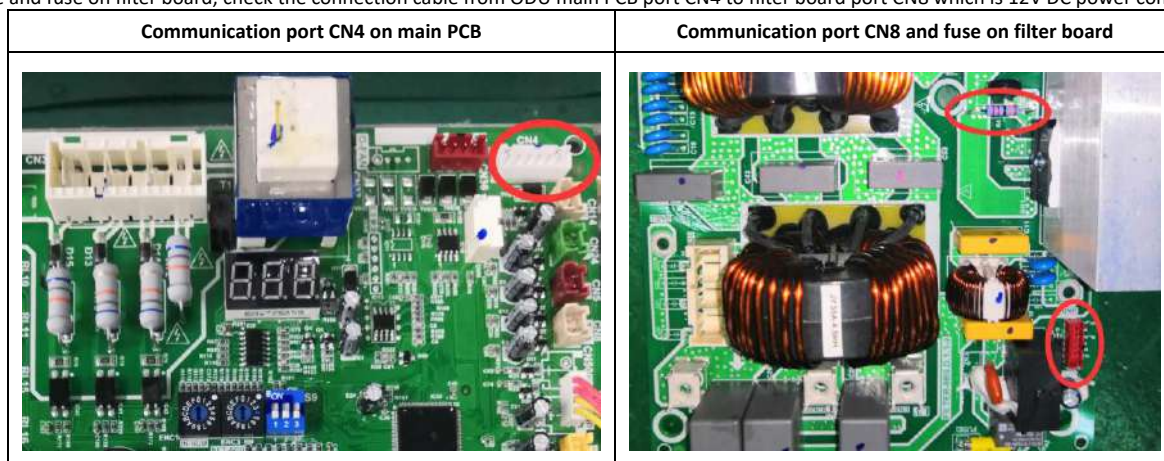

2.11 H4: Inverter module protection

2.11.1 Digital display output



2.11.2 Description

- H4 indicates compressor inverter module protection.
- The system stops running.
- Error code is displayed on the outdoor unit PCB.

2.11.3 Trigger / recover condition

- Trigger condition: Compressor appears three inverter module protections.
- Recover condition: Inverter module goes back to normal.
- Reset method: Manually restart.

2.11.4 Possible causes

- Inverter module protection.
- DC bus low or high voltage protection.
- MCE error.
- Zero speed protection.
- Phase sequence error.
- Excessive compressor frequency variation.
- Actual compressor frequency differs from target frequency.

2.11.5 Specific error codes for H4 inverter module protection

If an H4 error code is displayed, enter menu mode “n31” (refer to Part 5, 2.2.3 “menu mode”) to check the history error code to check the following specific error code: L0, L1, L2, L4, L5, L7, L8, L9.

Table 6-2.1: Specific error codes for error H4

| Specific error code ¹ | Content |
|----------------------------------|--|
| L0 | Inverter module protection |
| L1 | DC bus low voltage protection |
| L2 | DC bus high voltage protection |
| L4 | MCE error |
| L5 | Zero speed protection |
| L7 | Phase sequence error |
| L8 | Compressor frequency variation greater than 15Hz within one second protection |
| L9 | Actual compressor frequency differs from target frequency by more than 15Hz protection |

The specific error codes L0, L1, L2 and L4 can also be obtained from the inverter module LED indicators. If an inverter module error has occurred, LED2 is continuously on and LED1 flashes.

Figure 6-2.2: LED indicators LED1 and LED2 on inverter module

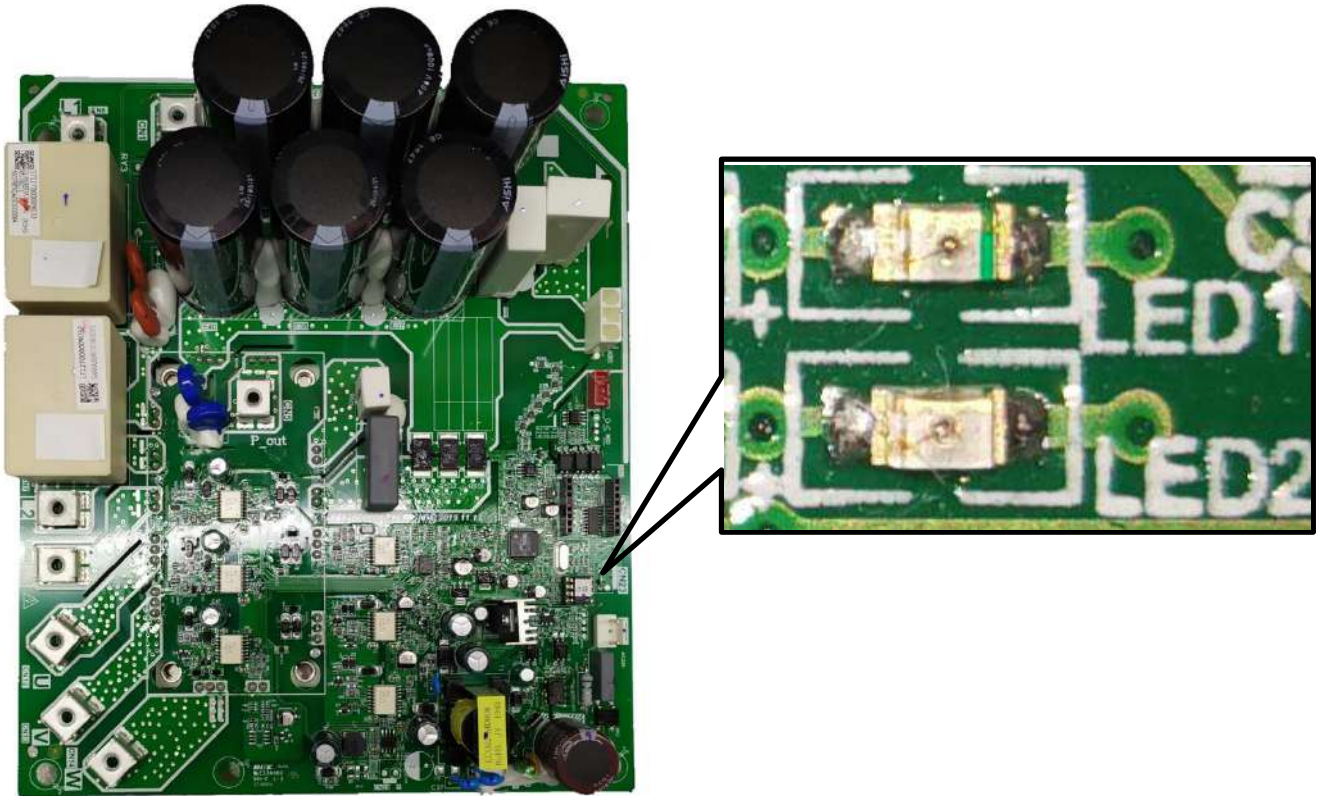
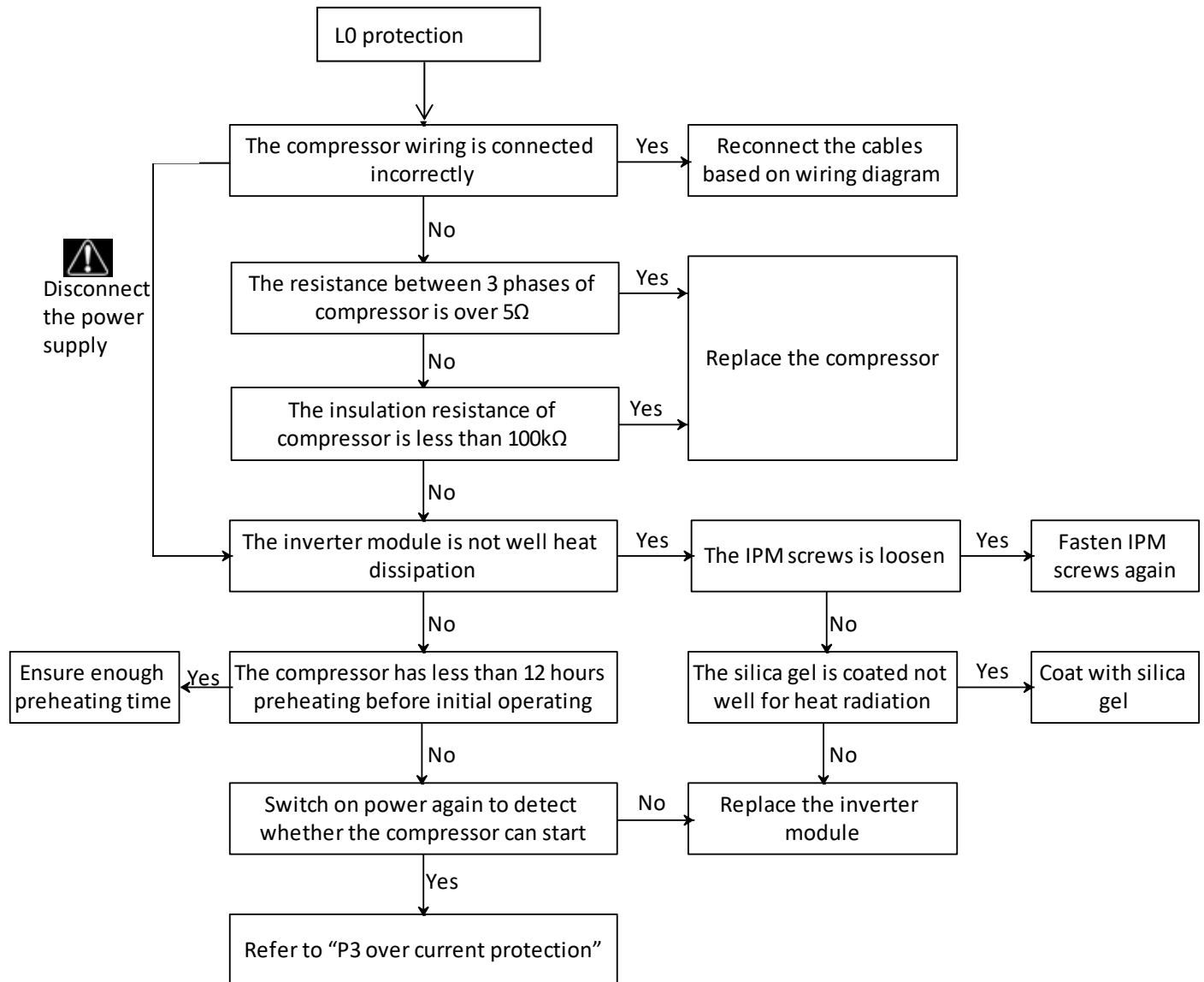

Table 2-6.2: Errors indicated on LED1

| LED1 flashing pattern | Corresponding error |
|---|-------------------------------------|
| Flashes 8 times and stops for 1 second, then repeats | L0 - Inverter module protection |
| Flashes 9 times and stops for 1 second, then repeats | L1 - DC bus low voltage protection |
| Flashes 10 times and stops for 1 second, then repeats | L2 - DC bus high voltage protection |
| Flashes 12 times and stops for 1 second, then repeats | L4 - MCE error |

2.11.6 L0: Inverter module protection



2.11.7 L1: DC bus low voltage protection

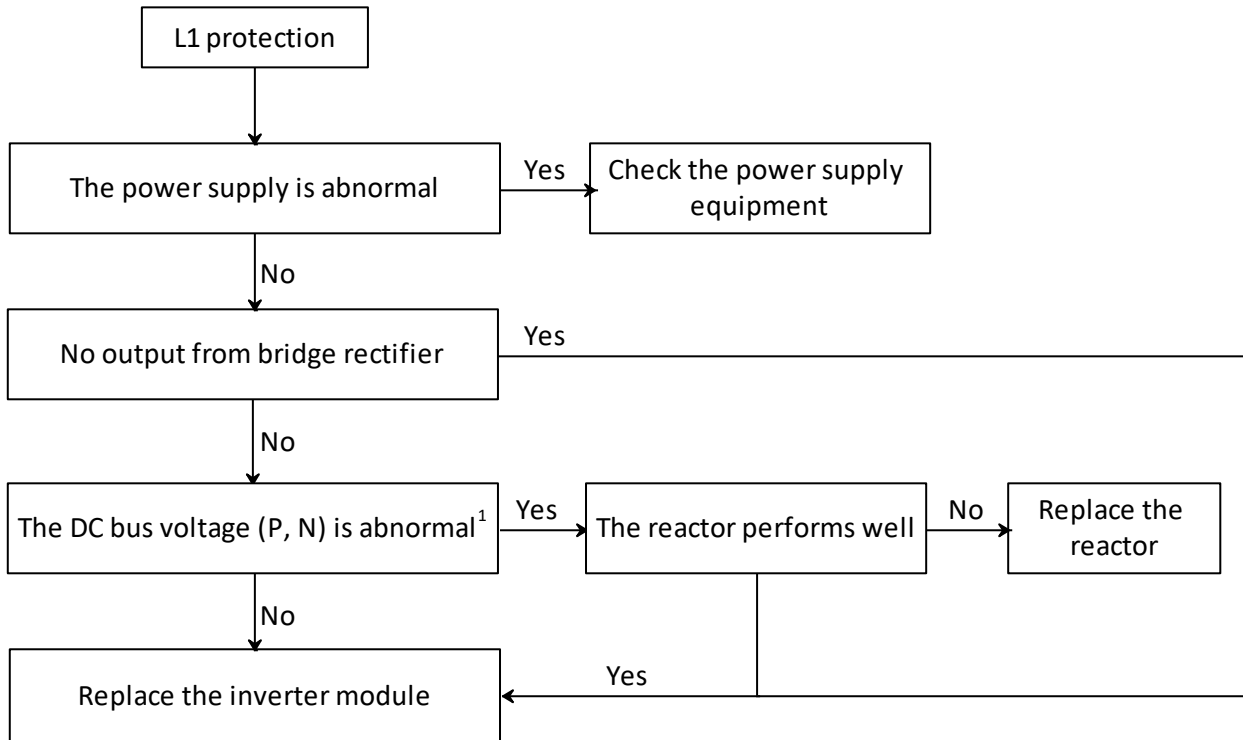

- Note:
- The normal DC voltage between terminals P and N on inverter module should be 450-650V. When the voltage is lower than 350V, L1 protection will be appeared.

Figure 6-2.3: P and N terminals on Inverter module



2.11.8 L2: DC bus high voltage protection

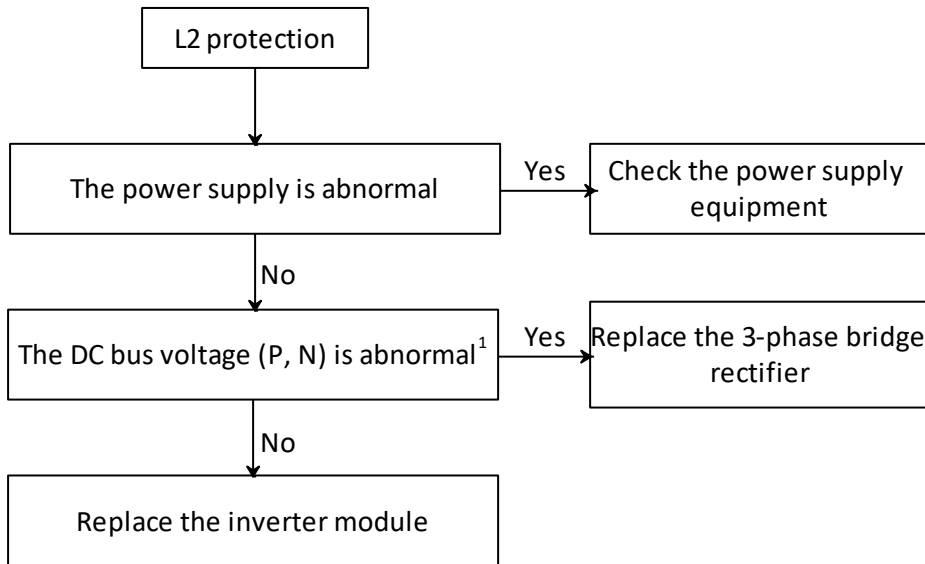

Note:

1. The normal DC voltage between terminals P and N on inverter module should be 520V. When the voltage is higher than 630V, L2 protection will be appeared.

Figure 6-2.4: P and N terminals on Inverter module



2.11.9 L4: MCE error



Disconnect the power supply

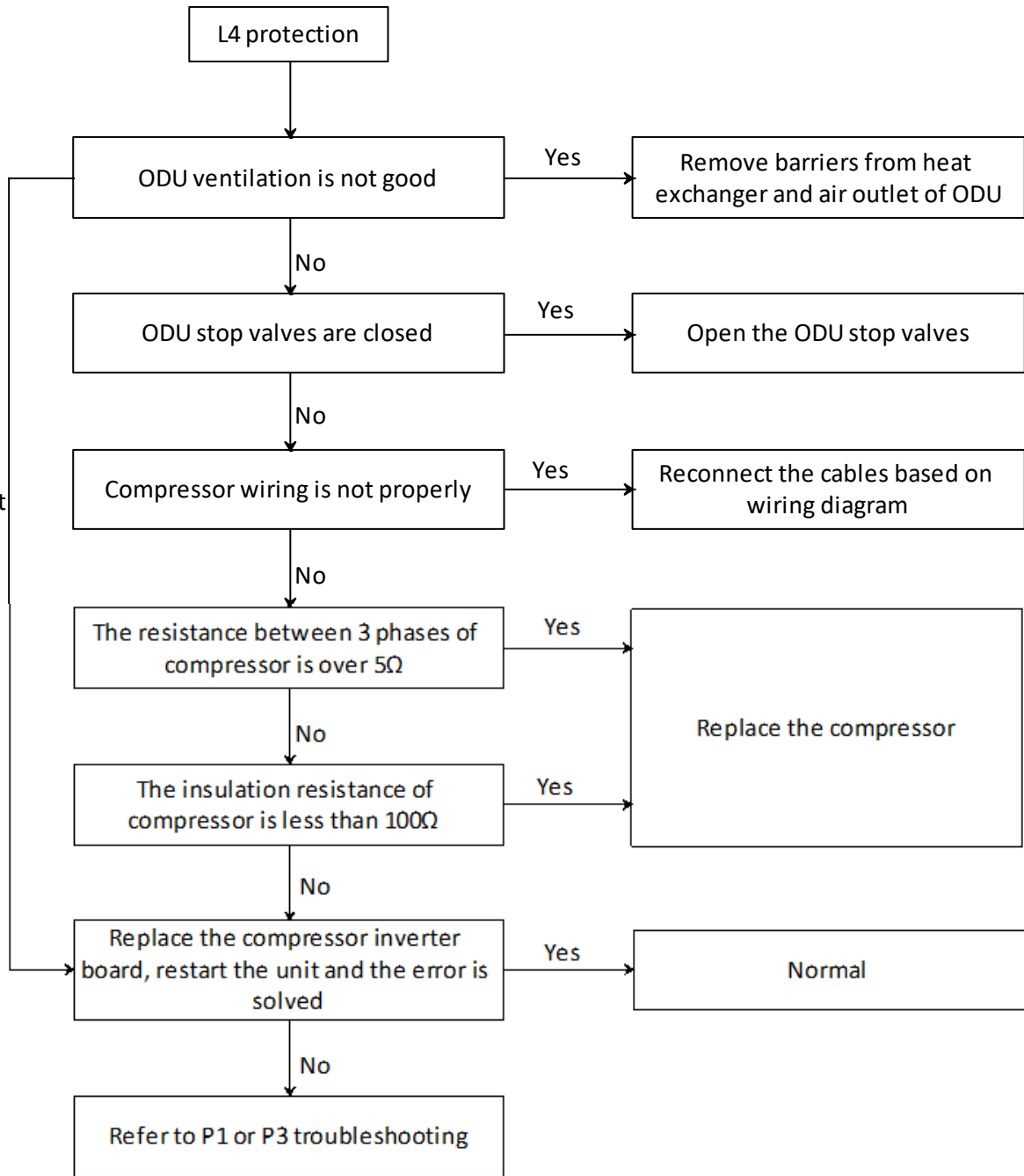

2.11.10 L5: Zero speed protection

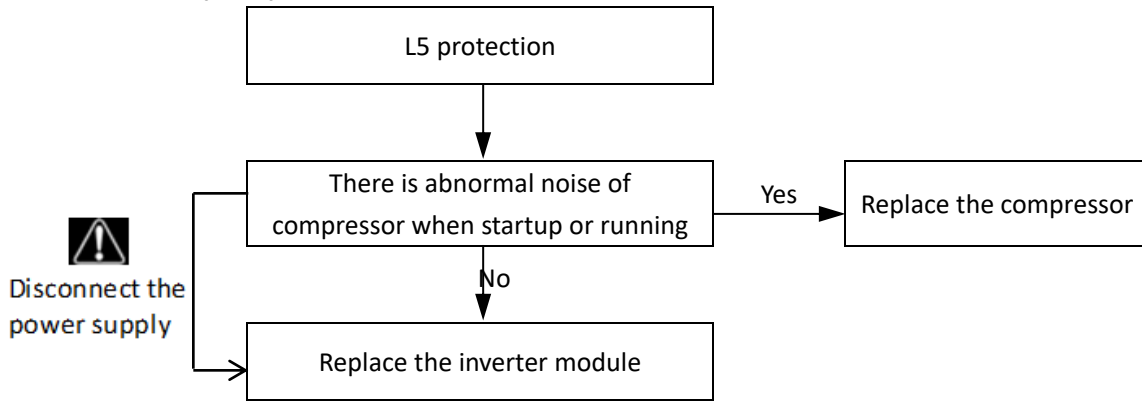

2.11.11 L7: Phase sequence error

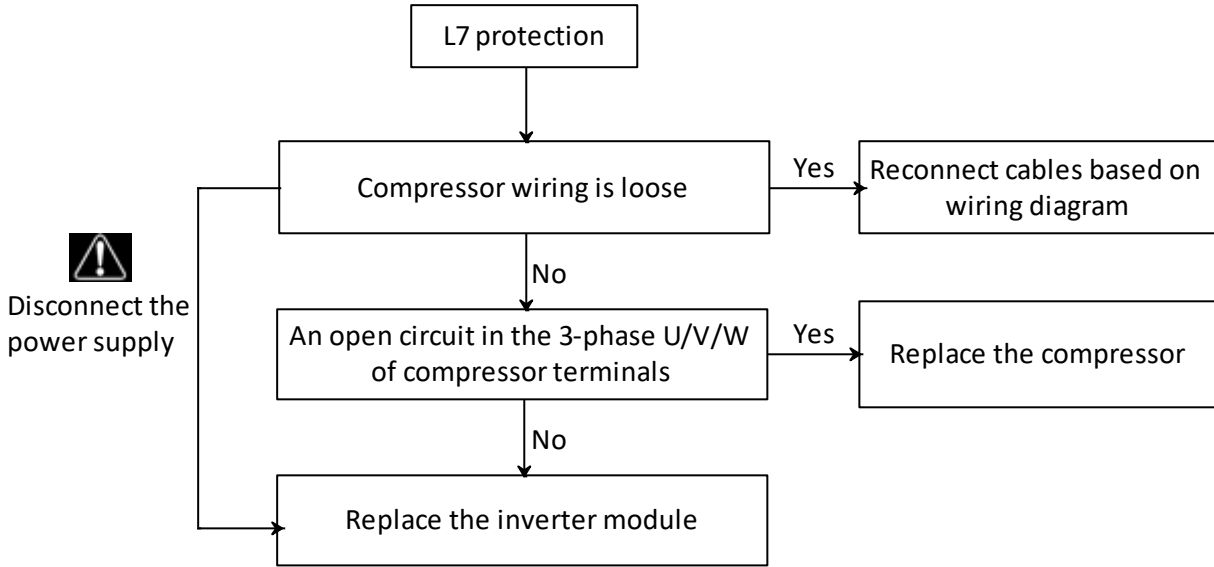

2.11.12 L8: Compressor frequency variation greater than 15Hz within one second protection

L9: Actual compressor frequency differs from target frequency by more than 15Hz protection

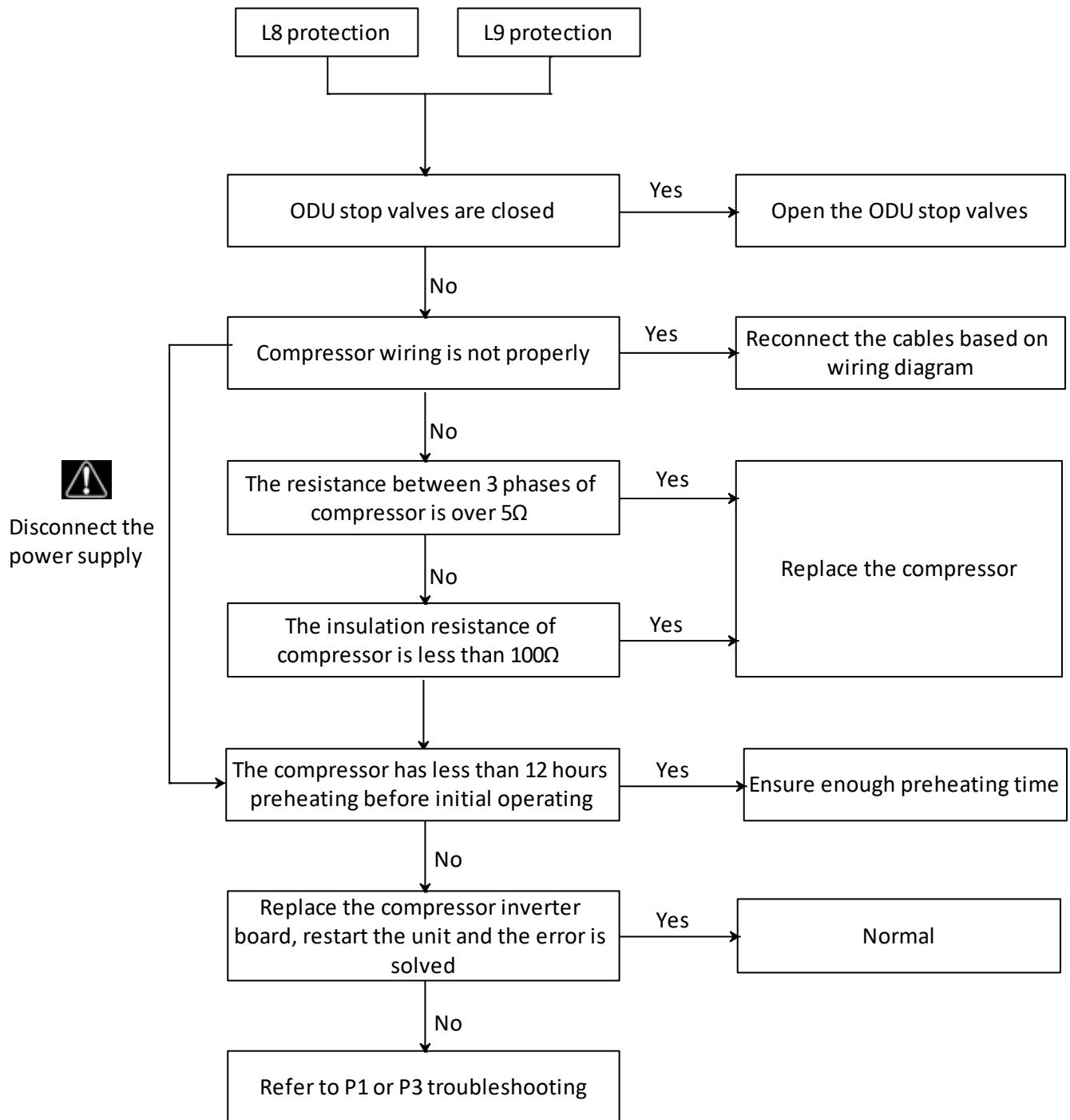

2.11.13 Compressor replacement procedure

Step 1: Remove faulty compressor and remove oil

- Remove the faulty compressor from the outdoor unit.
- Before removing the oil, shake the compressor so as to not allow impurities to remain settled at the bottom.
- Drain the oil out of the compressor and retain it for inspection. Normally the oil can be drained out from the compressor discharge pipe.

Figure 6-2.5: Draining oil from a compressor



Step 2: Inspect oil from faulty compressor

- The oil should be clear and transparent. Slightly yellow oil is not an indication of any problems. However, if the oil is dark, black or contains impurities, the system has problems and the oil needs to be changed. Refer to Figure 6-2.7 for further details regarding inspecting compressor oil. (If the compressor oil has been spoiled, the compressor will not be being lubricated effectively. The scroll plate, crankshaft and bearings will wear. Abrasion will lead to a larger load and higher current. More electric energy will get dissipated as heat and the temperature of the motor will become increasingly high. Finally, compressor damage or burnout will result.)

Step 3: Check oil in other compressors in the system

- If the oil drained from the faulty compressor is clean, go to Step 6.
- If the oil drained from the faulty compressor is spoiled (lightly or heavily), go to Step 4.

Step 4: Replace oil separator and accumulator

- If the oil from a compressor is spoiled (lightly or heavily), drain the oil from the oil separator and accumulator in that unit and then replace them.

Step 5: Check filters(s)

- If the oil from a compressor is spoiled (lightly or heavily), check the filter between the gas stop valve and the 4-way valve in that unit. If it is blocked, clean with nitrogen or replace.

Step 6: Replace the faulty compressor and re-fit the other compressors

- Replace the faulty compressor.
- If the oil had been spoiled and was drained from the non-faulty compressor in Step 3, use clean oil to clean them before re-fitting it into the unit. To clean, add oil into the compressor through the discharge pipe using a funnel, shake the compressor, and then drain the oil. Repeat several times and then re-fit the compressors into the units. (The discharge pipe is connected to the oil pool of the compressor by the inner oil balance pipe.)

Figure 6-2.6: Compressor piping



Step 7: Add compressor oil

- Add 2.3L of oil to each of the compressors from which oil was drained in Step 3.
- Only use FV50S oil. Different compressors require different types of oil. Using the wrong type of oil leads to various problems.
- Add additional 1.5L oil to the accumulator from which oil was drained in Step 4 such that the total amount of oil is 3.8L.

Step 8: Vacuum drying and refrigerant charging

- Once all the compressors and other components have been fully connected, vacuum dry the system and recharge refrigerant. Refer to the V4+i Engineering Data Book, Part 3.

Quantum Series (AU)



Figure 6-2.7: Inspecting compressor oil

This oil is black - it has been carbonized

This oil is a little yellow, but is clear and transparent and the condition is acceptable

This oil is still transparent but there are impurities which may clog the filter

Cloudy or gray oil indicates abnormal system operation

This oil contains particles of copper

2.12 H7: Unmatched total number of indoor units

2.12.1 Digital display output



2.12.2 Description

- Number of indoor units detected by the outdoor unit not same as number set on main PCB.
- The system stops running.
- Error code is displayed on the outdoor unit PCB.

2.12.3 Trigger / recover condition

- Trigger condition: At least one indoor unit cannot be detected by the outdoor unit for more than 20 minutes for the first time powered on or at least one indoor unit cannot be detected by the outdoor unit for more than 3 minutes.
- Recover condition: Number of indoor units detected by the outdoor unit is same as number set on main PCB.
- Reset method: Resume automatically.

2.12.4 Possible causes

- Number of indoor units set on main PCB not same as actual number of indoor units.
- Some indoor units are powered off.
- Communication wires between indoor and outdoor units not connected properly.
- Indoor unit PCB damaged.
- Indoor unit without address or indoor unit address duplicated.
- Main PCB damaged.

2.12.5 Procedure

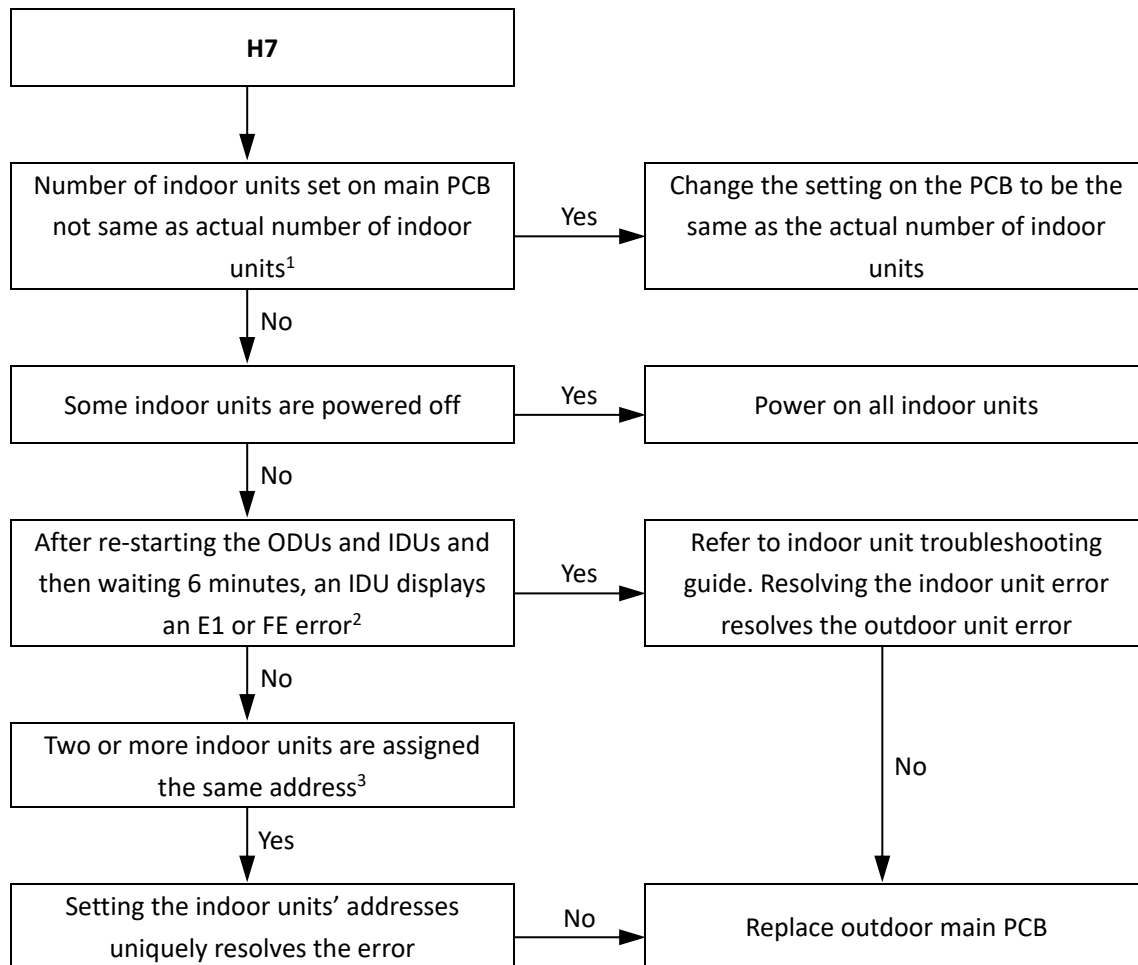

Notes:

1. The number of indoor units can be set on switches ENC1 and S9-3 on the main PCB.
2. Indoor unit error code E1 indicates a communication error between indoor and outdoor unit. Indoor unit error code FE indicates that an indoor unit has not been assigned an address.
3. Indoor unit addresses can be checked and manually assigned using indoor unit remote/wired controllers. Alternatively, indoor unit addresses can be automatically assigned by the outdoor unit.

2.13 H8: High pressure sensor error

2.13.1 Digital display output



2.13.2 Description

- High pressure sensor error.
- The system stops running.
- Error code is displayed on the unit with the error.

2.13.3 Trigger / recover condition

- Trigger condition: Discharge pressure \leq 0.3MPa.
- Recover condition: Discharge pressure $>$ 0.3MPa.
- Reset method: Resume automatically.

2.13.4 Possible causes

- Pressure sensor not connected properly or has malfunctioned.
- Insufficient refrigerant.
- Low pressure side blockage.
- Poor evaporator heat exchange.
- Main PCB damaged.

2.13.5 Procedure

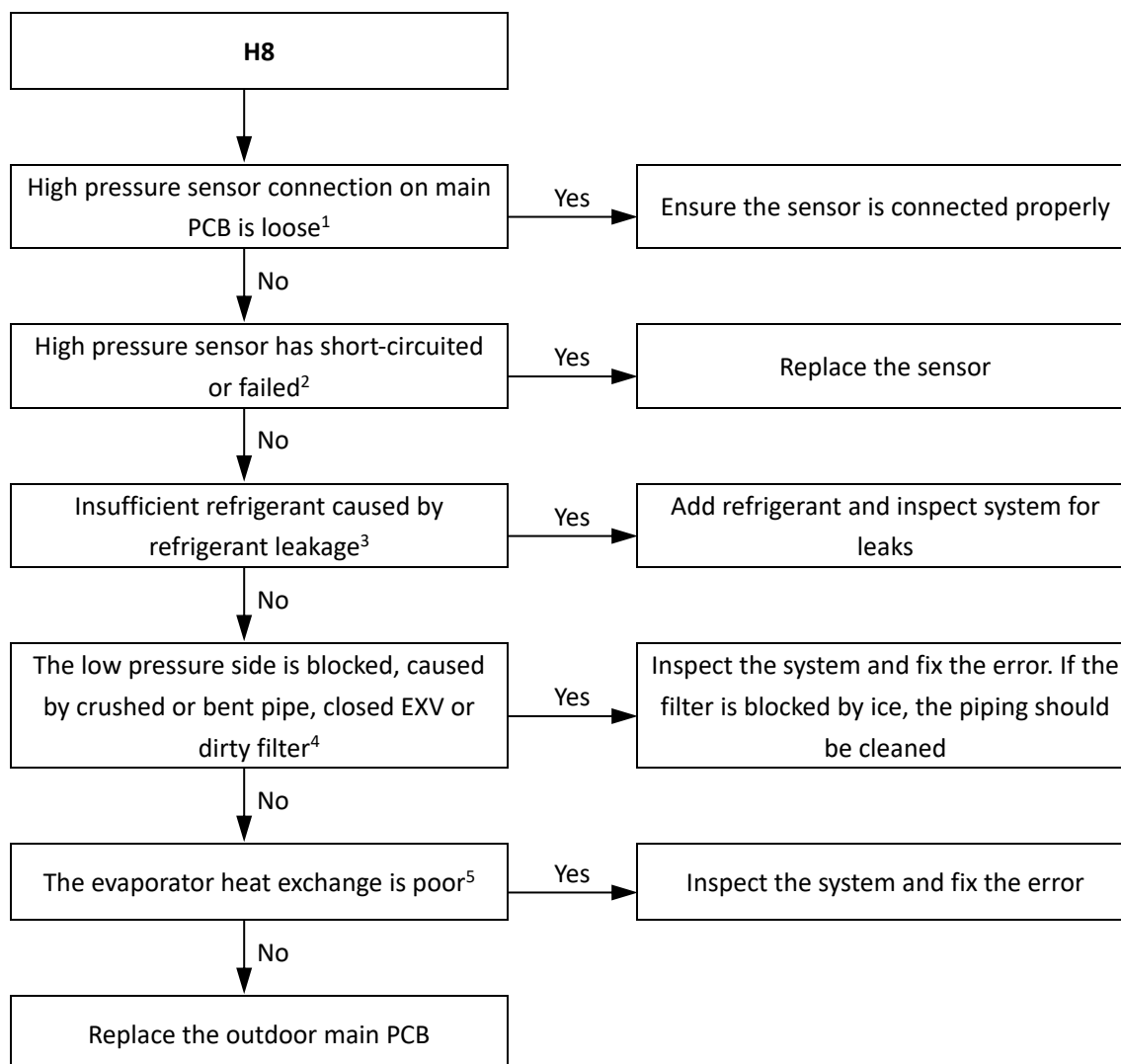

Notes:

1. High pressure sensor connection is port CN12 on the main PCB (labeled 8 in Figure 5-2.1 in Part 5, 2.1 "Ports").
2. Measure the resistance among the three terminals of the pressure sensor. If the resistance is of the order of mega Ohms or infinite, the pressure sensor has failed.
3. An insufficiency of refrigerant causes compressor discharge temperature to be higher than normal, discharge and suction pressures to be lower than normal and compressor current to be lower than normal, and may cause frosting to occur on the suction pipe. These issues disappear once sufficient refrigerant has been charged into the system. For normal system parameters refer to Table 6-3.4 and 6-3.5 in Part 6, 3.2 "Normal Operating Parameters of Refrigerant System".
4. A low pressure side blockage causes compressor discharge temperature to be higher than normal, suction pressure to be lower than normal and compressor current to be lower than normal, and may cause frosting to occur on the suction pipe. For normal system parameters refer to Table 6-3.4 and 6-3.5 in Part 6, 3.2 "Normal Operating Parameters of Refrigerant System".
5. In cooling mode check indoor heat exchangers, fans and air outlets for dirt/blockages. In heating mode check outdoor heat exchangers, fans and air outlets for dirt/blockages.

2.14 bL: High pressure switch protection on compressor inverter board

2.14.1 Digital display output



2.14.2 Description

- Discharge pipe high pressure protection or DC bus voltage abnormal.
- The system stops running.
- Error code is displayed on the outdoor unit PCB.

2.14.3 Trigger / recover condition

- Trigger condition: Discharge pressure $\geq 4.4\text{MPa}$ or DC bus voltage $\geq 325\text{V}$
- Recover condition: Discharge pressure $\leq 3.2\text{MPa}$ or DC bus voltage $< 325\text{V}$.
- Reset method: Resume automatically.

2.14.4 Possible causes

- Pressure sensor/switch not connected properly or has malfunctioned.
- High pressure side blockage.
- Poor condenser heat exchange.
- Main PCB damaged.
- Inverter module damaged
- PED board damaged.

2.14.5 Procedure

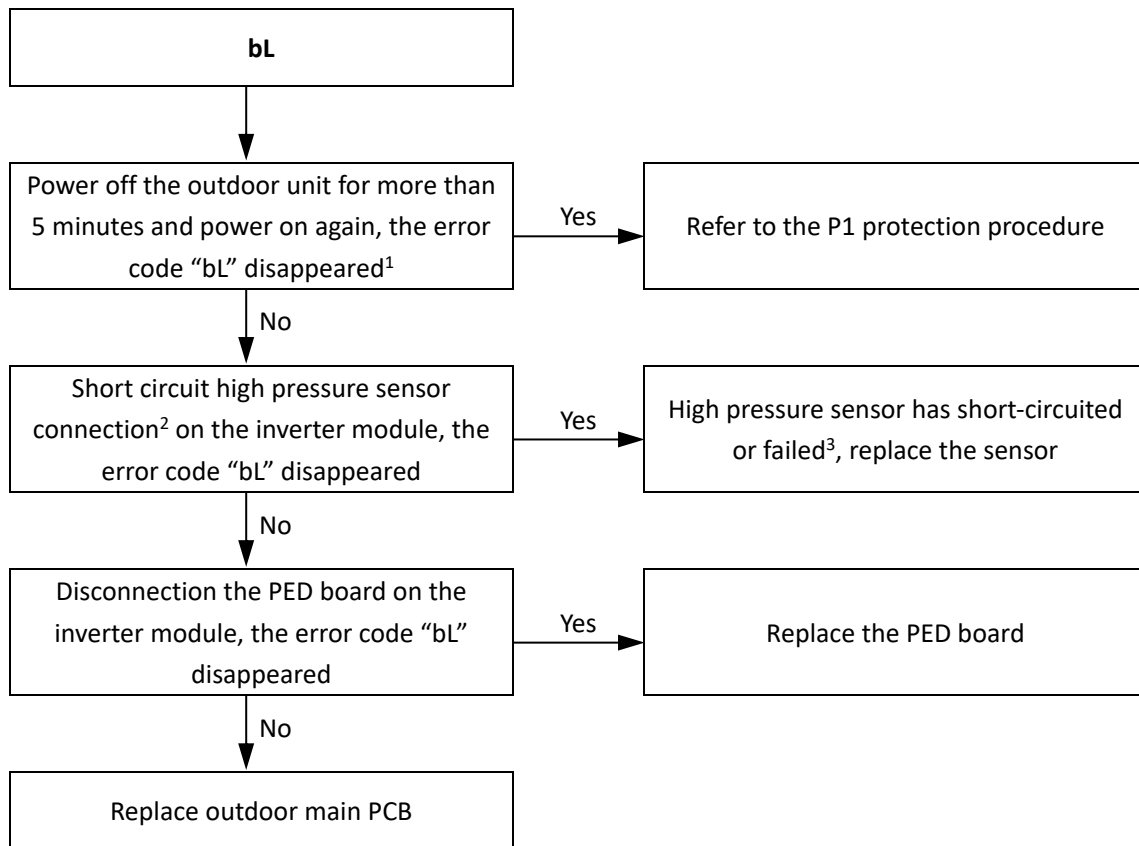

Notes:

1. For the first time the unit is powered on, the error code "bL" may disappeared in 5 minutes. It's normal and no need to be treated.
2. The high pressure sensor connection is port CN23 on the inverter module (labeled 8 in Figure 5-3.1 in Part 5, 3.1 "Ports").
3. Measure the resistance among the three terminals of the pressure sensor. If the resistance is of the order of mega Ohms or infinite, the pressure sensor has failed.

2.15 bH: PED board protection

2.15.1 Digital display output



2.15.2 Description

- PED board protection.
- The system stops running.
- Error code is displayed on the outdoor unit PCB.

2.15.3 Trigger / recover condition

- Trigger condition: Contact conglutination or PED board self-check failure.
- Recover condition: Contact conglutination problem resolved or PED board self-check success.
- Reset method: Resume automatically.

2.15.4 Possible causes

- Inverter module damaged.
- PED board damaged.

2.15.5 Procedure

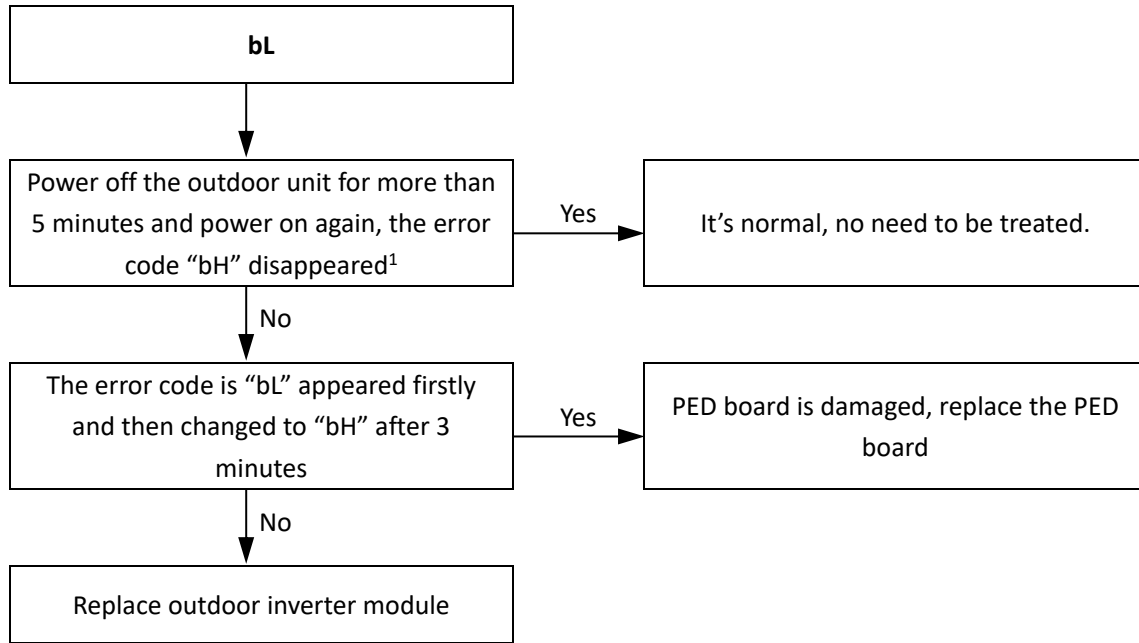

Notes:

1. For the first time the unit is powered on, the error code "bH" may disappear in 5 minutes. It's normal and no need to be treated.

2.16 P1: Discharge pipe high pressure protection

2.16.1 Digital display output



2.16.2 Description

- Discharge pipe high pressure protection.
- The system stops running.
- Error code is displayed on the outdoor unit PCB.

2.16.3 Trigger / recover condition

- Trigger condition: Discharge pressure ≥ 4.4 MPa.
- Recover condition: Discharge pressure ≤ 3.2 MPa.
- Reset method: Resume automatically.

2.16.4 Possible causes

- Outdoor unit stop valves are closed.
- Pressure sensor/switch not connected properly or has malfunctioned.
- Excess refrigerant.
- System contains air or nitrogen.
- High pressure side blockage.
- Poor condenser heat exchange.
- Main PCB damaged.

2.16.5 Procedure

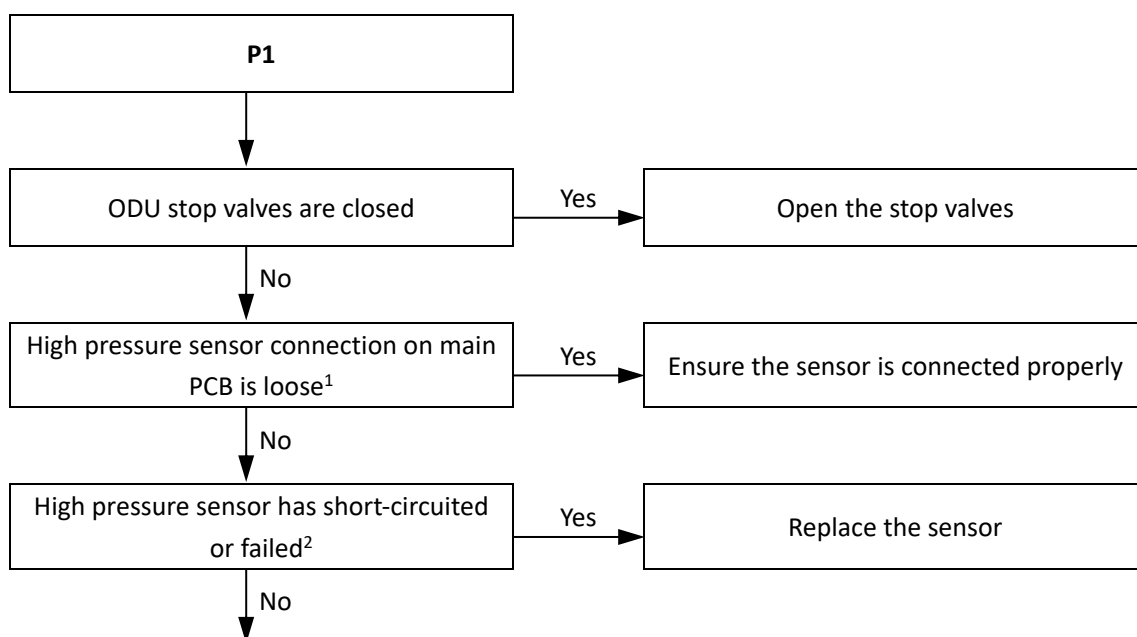

Flowchart continued on next page ...

... flowchart continued from previous page

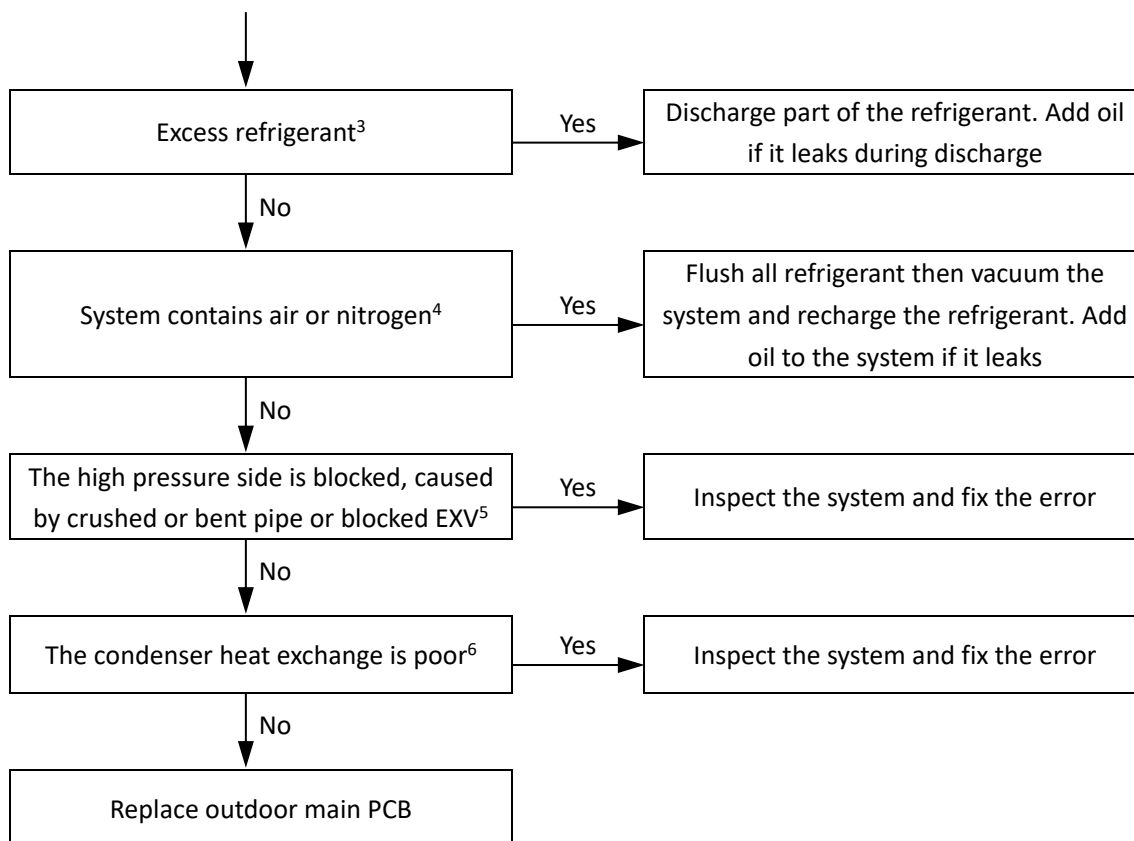

Notes:

4. The high pressure sensor connection is port CN12 on the main PCB (labeled 8 in Figure 5-2.1 in Part 5, 2.1 "Ports").
5. Measure the resistance among the three terminals of the pressure sensor. If the resistance is of the order of mega Ohms or infinite, the pressure sensor has failed.
6. Excess refrigerant causes discharge temperature to be lower than normal, discharge pressure to be higher than normal and suction pressure to be higher than normal. For normal system parameters refer to Table 6-3.4 and 6-3.5 in Part 6, 3.2 "Normal Operating Parameters of Refrigerant System".
7. Air or nitrogen in the system causes discharge temperature to be higher than normal, discharge pressure to be higher than normal, compressor current to be higher than normal, abnormal compressor noise and an unsteady pressure meter reading. For normal system parameters refer to Table 6-3.4 and 6-3.5 in Part 6, 3.2 "Normal Operating Parameters of Refrigerant System".
8. High pressure side blockage causes discharge temperature to be higher than normal, discharge pressure to be higher than normal and suction pressure to be lower than normal. For normal system parameters refer to Table 6-3.4 and 6-3.5 in Part 6, 3.2 "Normal Operating Parameters of Refrigerant System".
9. In cooling mode check outdoor heat exchangers, fans and air outlets for dirt/blockages. In heating mode check indoor heat exchangers, fans and air outlets for dirt/blockages.

2.17 P2, H5: Suction pipe low pressure protection

2.17.1 Digital display output



2.17.2 Description

- Suction pipe low pressure protection.
- The system stops running.
- Error code is displayed on outdoor unit PCB.

2.17.3 Trigger / recover condition

- Trigger condition:
 - For P2 protection: Suction pressure $\leq 0.05\text{MPa}$.
 - For H5 protection: P2 protection appears three times in 30 minutes.
- Recover condition: Suction pressure $\geq 0.15\text{MPa}$.
- Reset method:
 - For P2 protection: Resume automatically.
 - For H5 protection: Manually restart.

2.17.4 Possible causes

- Outdoor unit stop valves are closed.
- Insufficient refrigerant.
- Low pressure side blockage.
- Poor evaporator heat exchange.
- Main PCB damaged.

2.17.5 Procedure

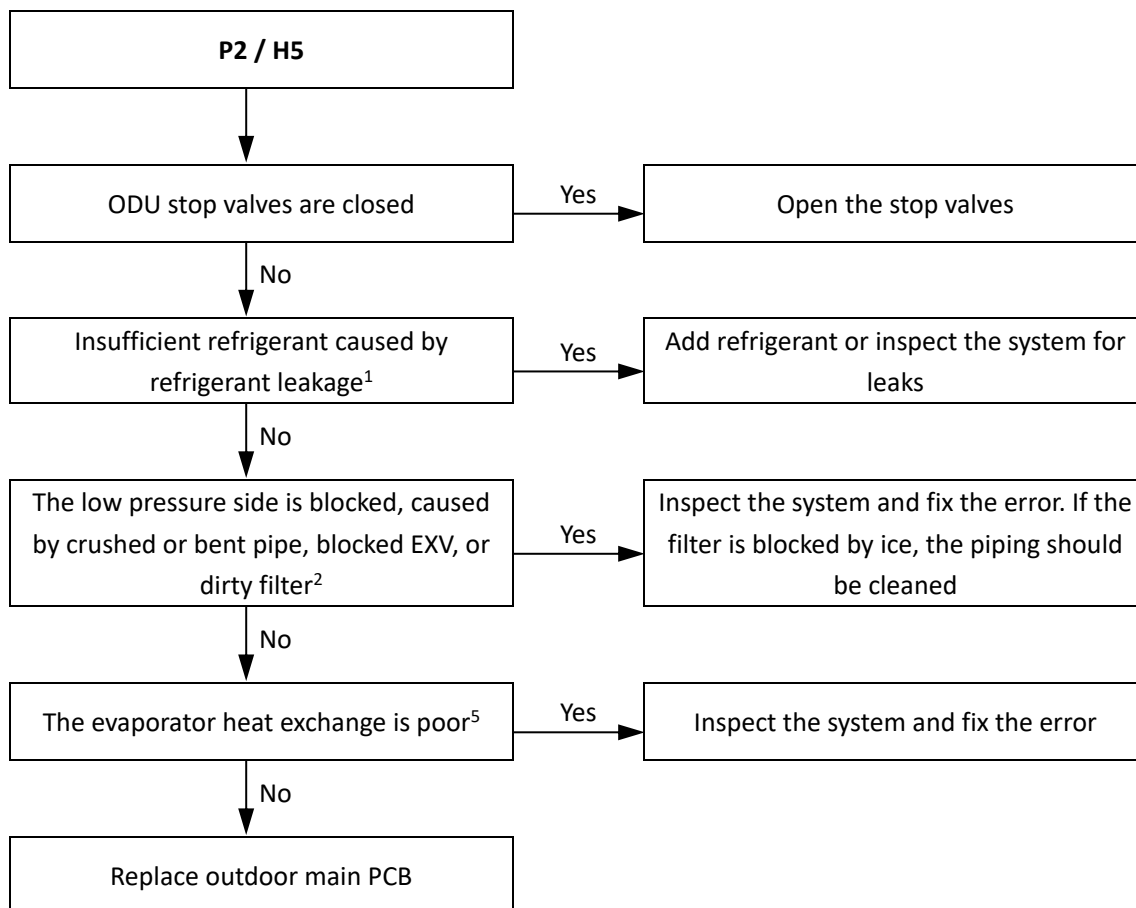

Notes:

1. An insufficiency of refrigerant causes compressor discharge temperature to be higher than normal, discharge and suction pressures to be lower than normal and compressor current to be lower than normal, and may cause frosting to occur on the suction pipe. These issues disappear once sufficient refrigerant has been charged into the system. For normal system parameters refer to Table 6-3.4 and 6-3.5 in Part 6, 3.2 "Normal Operating Parameters of Refrigerant System".
2. A low pressure side blockage causes compressor discharge temperature to be higher than normal, suction pressure to be lower than normal and compressor current to be lower than normal, and may cause frosting to occur on the suction pipe. For normal system parameters refer to Table 6-3.4 and 6-3.5 in Part 6, 3.2 "Normal Operating Parameters of Refrigerant System".
3. In cooling mode check indoor heat exchangers, fans and air outlets for dirt/blockages. In heating mode check outdoor heat exchangers, fans and air outlets for dirt/blockages.

2.18 P3: Compressor current protection
2.18.1 Digital display output

2.18.2 Description

- P3 indicates current protection on compressor.
- The system stops running.
- Error code is displayed on the outdoor unit PCB.

2.18.3 Trigger / recover condition

- Trigger condition: Current of compressor LNB65FAGMC \geq 29A.
- Recover condition: Current of compressor LNB65FAGMC $<$ 29A.
- Reset method: Resume automatically.

2.18.4 Possible causes

- | | |
|--|---|
| <ul style="list-style-type: none"> ▪ Outdoor unit stop valves are closed. ▪ Indoor load too large. ▪ Power supply abnormal. ▪ Sudden interruption of power to IDUs. ▪ Excess refrigerant. ▪ System contains air or nitrogen. | <ul style="list-style-type: none"> ▪ Poor condenser heat exchange. ▪ High pressure side blockage. ▪ Inverter module damaged. ▪ Compressor damaged. ▪ Main PCB damaged. |
|--|---|

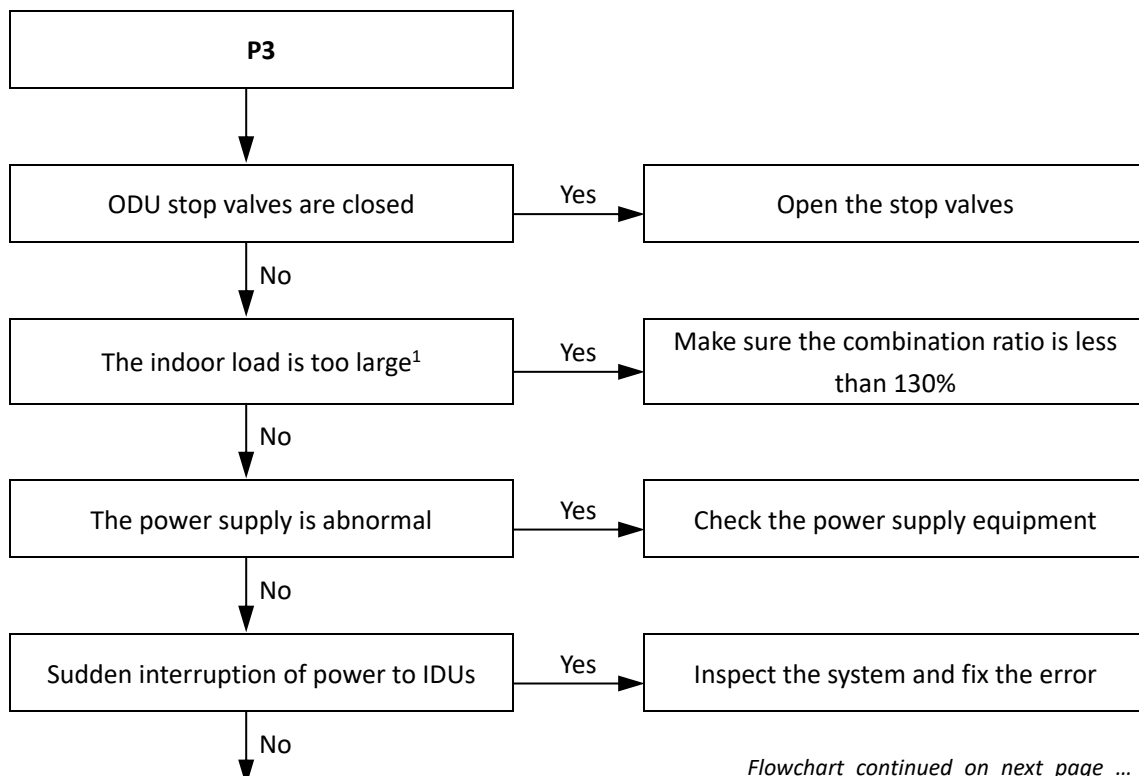
2.18.5 Procedure

Flowchart continued on next page ...

... flowchart continued from previous page

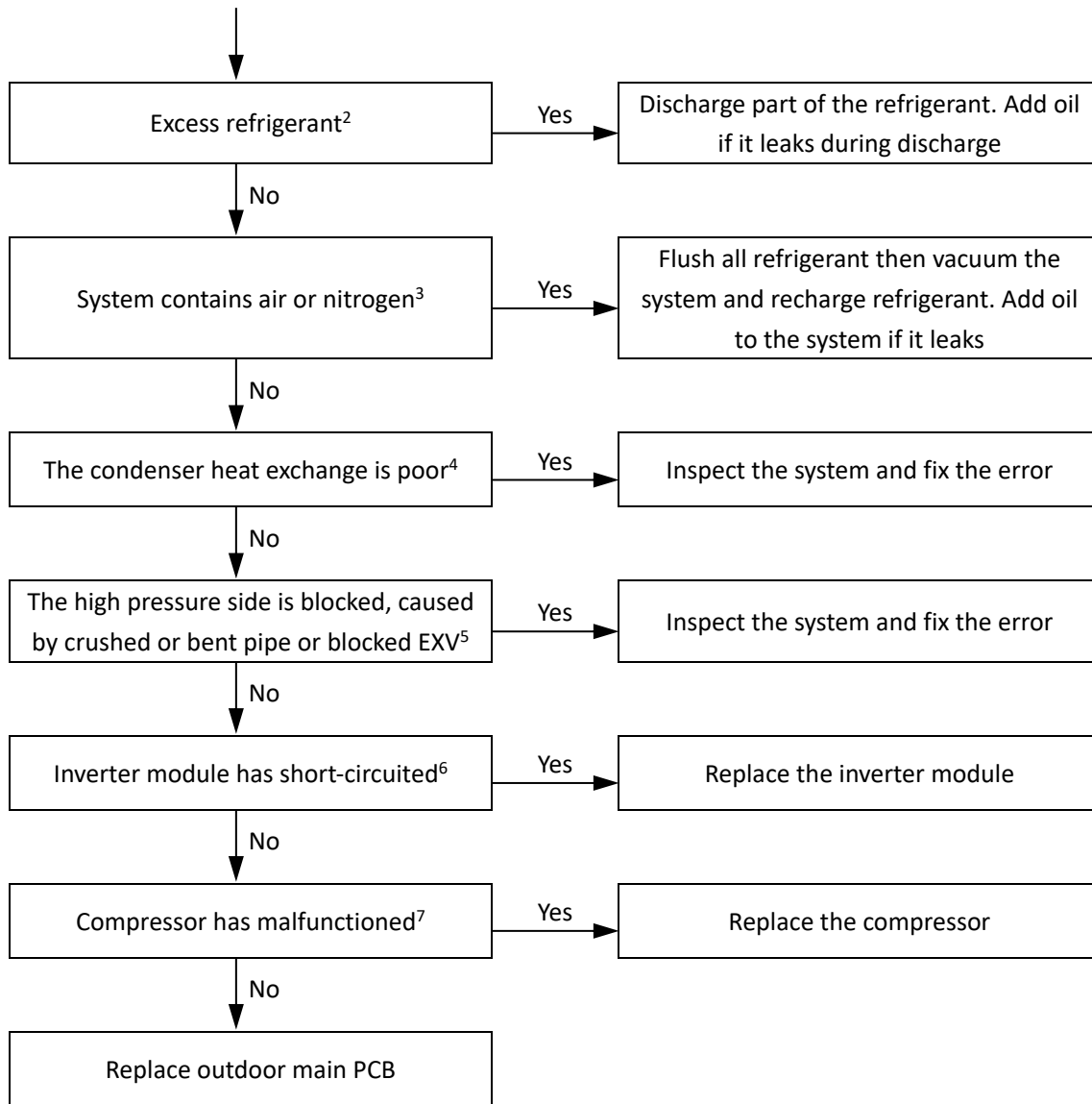

Notes:

1. An indoor load that is too large causes suction and discharge temperatures to be higher than normal. For normal system parameters refer to Table 6-3.4 and 6-3.5 in Part 6, 3.2 "Normal Operating Parameters of Refrigerant System".
2. Excess refrigerant causes discharge temperature to be lower than normal, discharge pressure to be higher than normal and suction pressure to be higher than normal. For normal system parameters refer to Table 6-3.4 and 6-3.5 in Part 6, 3.2 "Normal Operating Parameters of Refrigerant System".
3. Air or nitrogen in the system causes discharge temperature to be higher than normal, discharge pressure to be higher than normal, compressor current to be higher than normal, abnormal compressor noise and an unsteady pressure meter reading. For normal system parameters refer to Table 6-3.4 and 6-3.5 in Part 6, 3.2 "Normal Operating Parameters of Refrigerant System".
4. In cooling mode check outdoor heat exchangers, fans and air outlets for dirt/blockages. In heating mode check indoor heat exchangers, fans and air outlets for dirt/blockages.
5. High pressure side blockage causes discharge temperature to be higher than normal, discharge pressure to be higher than normal and suction pressure to be lower than normal. For normal system parameters refer to Table 6-3.4 and 6-3.5 in Part 6, 3.2 "Normal Operating Parameters of Refrigerant System".
6. Set a multi-meter to buzzer mode and test any two terminals of P N U V W of the inverter module. If the buzzer sounds, the inverter module has short-circuited.
7. The normal resistances of the inverter compressor are 0.7-1.5Ω among U V W and infinite between each of U V W and ground. If any of the resistances differ from these specifications, the compressor has malfunctioned.

2.19 P4: Discharge temperature protection
2.19.1 Digital display output

2.19.2 Description

- Discharge temperature protection.
- The system stops running.
- Error code is displayed on the unit with the error.

2.19.3 Trigger / recover condition

- Trigger condition:
Discharge temperature (T5) > 110°C.
- Recover condition: Discharge temperature (T5) < 85 °C.
- Reset method:
Resume automatically.

2.19.4 Possible causes

- Outdoor unit stop valves are closed.
- Temperature sensor/switch not connected properly or has malfunctioned.
- Insufficient refrigerant.
- System blockage.
- Indoor load too large.
- System contains air or nitrogen.
- Poor condenser heat exchange.
- Main PCB damaged.

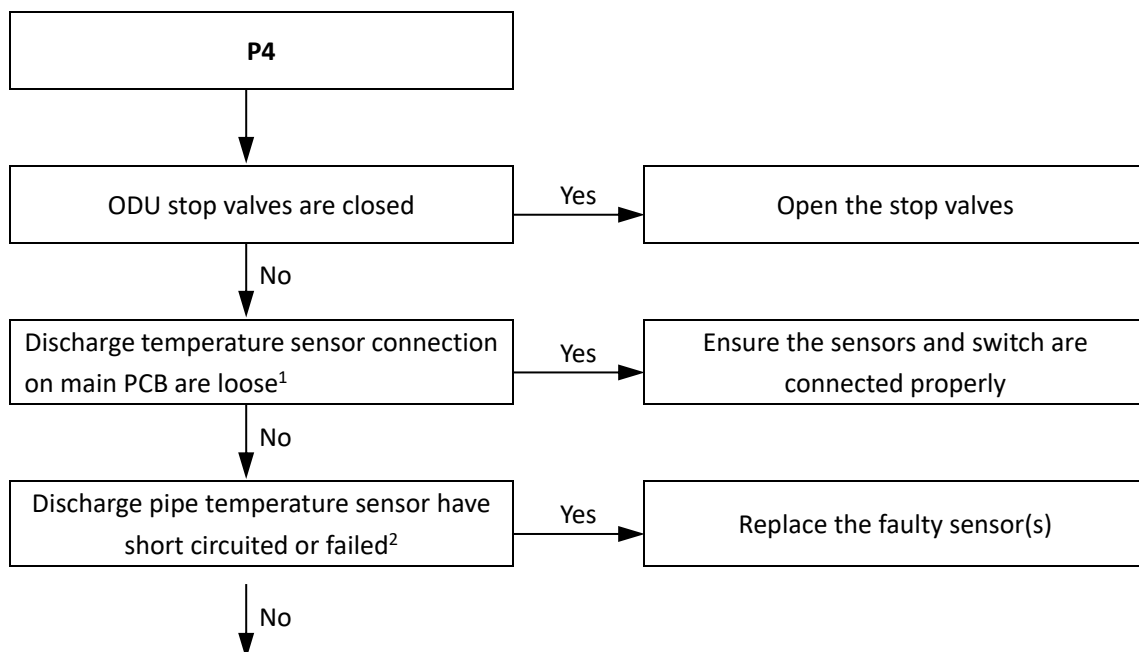
2.19.5 Procedure

Flowchart continued on next page ...

... flowchart continued from previous page

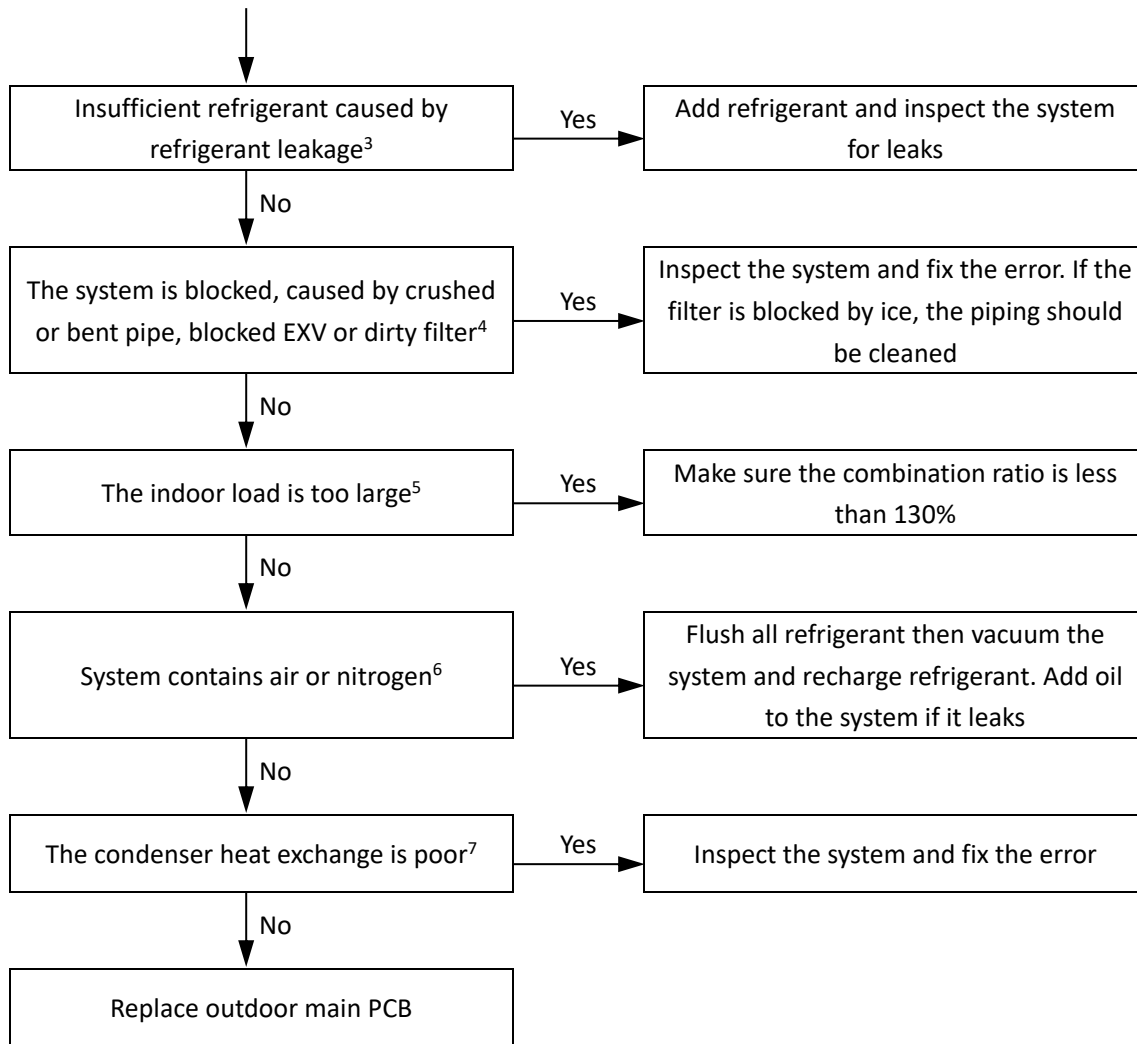

Notes:

1. Discharge pipe temperature sensor connections is port CN5 on the main PCB (labeled 6 in Figure 5-2.1 in Part 5, 2.1 "Ports").
2. Measure sensor resistance. If the resistance is too low, the sensor has short-circuited. If the resistance is not consistent with the sensor's resistance characteristics table, the sensor has failed. Refer to Table 6-3.2 in Part 6, 3.1 "Temperature Sensor Resistance Characteristics".
3. An insufficiency of refrigerant causes compressor discharge temperature to be higher than normal, discharge and suction pressures to be lower than normal and compressor current to be lower than normal, and may cause frosting to occur on the suction pipe. These issues disappear once sufficient refrigerant has been charged into the system. For normal system parameters refer to Table 6-3.4 and 6-3.5 in Part 6, 3.2 "Normal Operating Parameters of Refrigerant System".
4. A low pressure side blockage causes compressor discharge temperature to be higher than normal, suction pressure to be lower than normal and compressor current to be lower than normal, and may cause frosting to occur on the suction pipe. For normal system parameters refer to Table 6-3.4 and 6-3.5 in Part 6, 3.2 "Normal Operating Parameters of Refrigerant System".
5. An indoor load that is too large causes suction and discharge temperatures to be higher than normal. For normal system parameters refer to Table 6-3.4 and 6-3.5 in Part 6, 3.2 "Normal Operating Parameters of Refrigerant System".
6. Air or nitrogen in the system causes discharge temperature to be higher than normal, discharge pressure to be higher than normal, compressor current to be higher than normal, abnormal compressor noise and an unsteady pressure meter reading. For normal system parameters refer to Table 6-3.4 and 6-3.5 in Part 6, 3.2 "Normal Operating Parameters of Refrigerant System".
7. In cooling mode check outdoor heat exchangers, fans and air outlets for dirt/blockages. In heating mode check indoor heat exchangers, fans and air outlets for dirt/blockages.

2.20 P5: Outdoor heat exchanger temperature protection

2.20.1 Digital display output



2.20.2 Description

- Outdoor heat exchanger temperature protection.
- The system stops running.
- Error code is displayed on the unit with the error.

2.20.3 Trigger / recover condition

- Trigger condition: Outdoor heat exchanger temperature (T3) $\geq 65^{\circ}\text{C}$.
- Recover condition: Outdoor heat exchanger temperature (T3) $< 55^{\circ}\text{C}$.
- Reset method: Resume automatically.

2.20.4 Possible causes

- Outdoor unit stop valves are closed.
- Temperature sensor not connected properly or has malfunctioned.
- Indoor load too large.
- System contains air or nitrogen.
- Poor condenser heat exchange.
- High pressure side blockage.
- Main PCB damaged.

2.20.5 Procedure

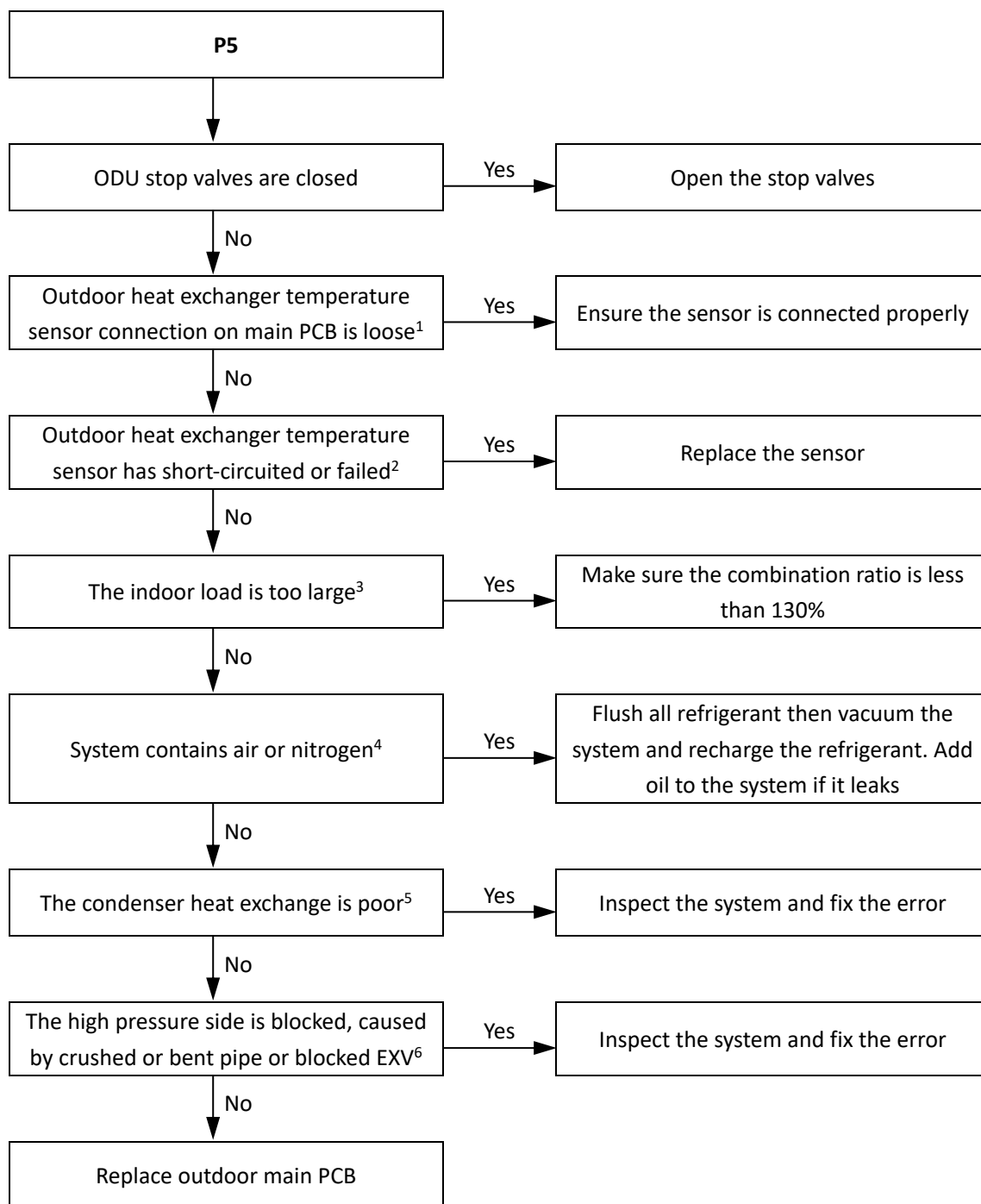

Notes:

1. Outdoor heat exchanger temperature sensor connection is port CN1 on the main PCB (labeled 11 in Figure 5-2.1 in Part 5, 2.1 "Ports").
2. Measure sensor resistance. If the resistance is too low, the sensor has short-circuited. If the resistance is not consistent with the sensor's resistance characteristics table, the sensor has failed. Refer to Table 6-3.1 in Part 6, 3.1 "Temperature Sensor Resistance Characteristics".
3. An indoor load that is too large causes suction and discharge temperatures to be higher than normal. For normal system parameters refer to Table 6-3.4 and 6-3.5 in Part 6, 3.2 "Normal Operating Parameters of Refrigerant System".
4. Air or nitrogen in the system causes discharge temperature to be higher than normal, discharge pressure to be higher than normal, compressor current to be higher than normal, abnormal compressor noise and an unsteady pressure meter reading. For normal system parameters refer to Table 6-3.4 and 6-3.5 in Part 6, 3.2 "Normal Operating Parameters of Refrigerant System".
5. In cooling mode check outdoor heat exchangers, fans and air outlets for dirt/blockages. In heating mode check indoor heat exchangers, fans and air outlets for dirt/blockages.
6. High pressure side blockage causes discharge temperature to be higher than normal, discharge pressure to be higher than normal and suction pressure to be lower than normal. For normal system parameters refer to Table 6-3.4 and 6-3.5 in Part 6, 3.2 "Normal Operating Parameters of Refrigerant System".

2.21 P8: Typhoon protection

2.21.1 Digital display output



2.21.2 Description

- P8 indicates strong wind protection.
- The system stops running.
- Error code is displayed on the outdoor unit PCB.

2.21.3 Trigger / recover condition

- Trigger condition:
Fan speed ≥ 400 rps when the outdoor unit is not start up.
- Recover condition:
Both the upper and lower fan speed < 400 rps for more than 120S.
- Reset method:
Resume automatically.

2.21.4 Possible causes

- There is strong wind around the outdoor unit.
- DC fan motor is damaged.
- Main PCB damaged.

2.21.5 Procedure

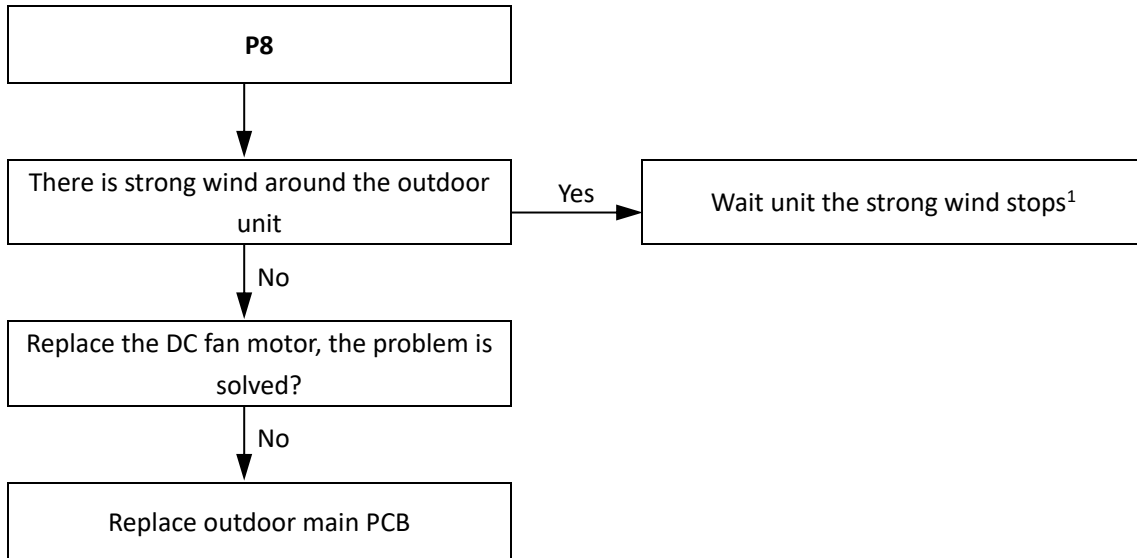

Notes:

1. P8 protection recovers in 2 minutes when the strong wind stops.

2.22 PL: Inverter module temperature protection

2.22.1 Digital display output



2.22.2 Description

- PL indicates inverter module temperature protection.
- The system stops running.
- Error code is displayed on the outdoor unit PCB.

2.22.3 Trigger / recover condition

- Trigger condition:
Inverter module heat sink temperature (T_f) $\geq 72^\circ\text{C}$.
- Recover condition:
Inverter module heat sink temperature (T_f) $< 66^\circ\text{C}$
- Reset method:
Resume automatically.

2.22.4 Possible causes

- Blocked, dirty or loose heat sink.
- Temperature sensor not connected properly or has malfunctioned.
- Main PCB damaged.

2.22.5 Procedure

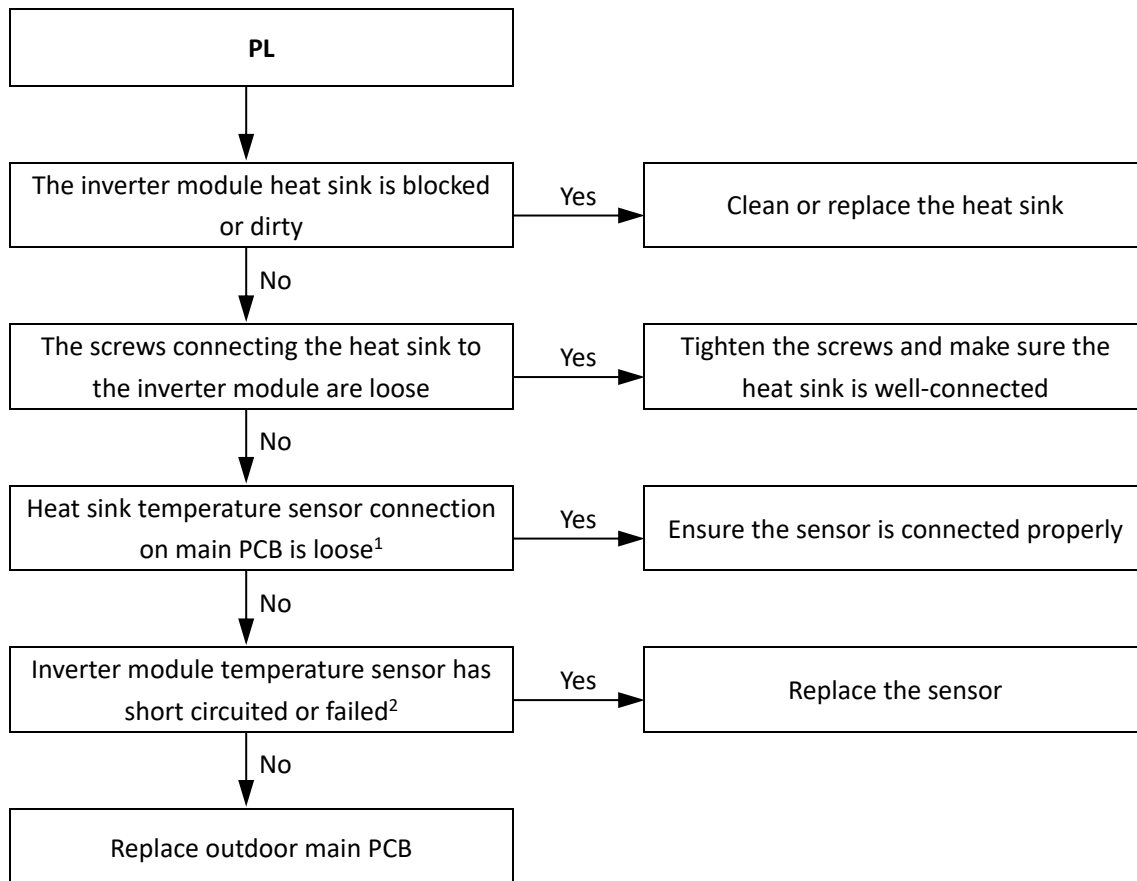

Notes:

1. Heat sink temperature sensor connection is port CN14 on the main PCB (labeled 4 in Figure 5-2.1 in Part 5, 2.1 "Ports").
2. Measure sensor resistance. If the resistance is too low, the sensor has short-circuited. If the resistance is not consistent with the sensor's resistance characteristics table, the sensor has failed. Refer to Table 6-3.3 in Part 6, 3.1 "Temperature Sensor Resistance Characteristics".

3 Appendix to Part 6

3.1 Temperature Sensor Resistance Characteristics

Table 6-3.1: Outdoor ambient temperature sensor, outdoor heat exchanger temperature sensor and refrigerant cooling pipe temperature sensor resistance characteristics

| Temperature (°C) | Resistance (kΩ) | Temperature (°C) | Resistance (kΩ) | Temperature (°C) | Resistance (kΩ) | Temperature (°C) | Resistance (kΩ) |
|------------------|-----------------|------------------|-----------------|------------------|-----------------|------------------|-----------------|
| -20 | 115.3 | 20 | 12.64 | 60 | 2.358 | 100 | 0.6297 |
| -19 | 108.1 | 21 | 12.06 | 61 | 2.272 | 101 | 0.6115 |
| -18 | 101.5 | 22 | 11.50 | 62 | 2.191 | 102 | 0.5939 |
| -17 | 96.34 | 23 | 10.97 | 63 | 2.112 | 103 | 0.5768 |
| -16 | 89.59 | 24 | 10.47 | 64 | 2.037 | 104 | 0.5604 |
| -15 | 84.22 | 25 | 10.00 | 65 | 1.965 | 105 | 0.5445 |
| -14 | 79.31 | 26 | 9.551 | 66 | 1.896 | 106 | 0.5291 |
| -13 | 74.54 | 27 | 9.124 | 67 | 1.830 | 107 | 0.5143 |
| -12 | 70.17 | 28 | 8.720 | 68 | 1.766 | 108 | 0.4999 |
| -11 | 66.09 | 29 | 8.336 | 69 | 1.705 | 109 | 0.4860 |
| -10 | 62.28 | 30 | 7.971 | 70 | 1.647 | 110 | 0.4726 |
| -9 | 58.71 | 31 | 7.624 | 71 | 1.591 | 111 | 0.4596 |
| -8 | 56.37 | 32 | 7.295 | 72 | 1.537 | 112 | 0.4470 |
| -7 | 52.24 | 33 | 6.981 | 73 | 1.485 | 113 | 0.4348 |
| -6 | 49.32 | 34 | 6.684 | 74 | 1.435 | 114 | 0.4230 |
| -5 | 46.57 | 35 | 6.400 | 75 | 1.387 | 115 | 0.4116 |
| -4 | 44.00 | 36 | 6.131 | 76 | 1.341 | 116 | 0.4006 |
| -3 | 41.59 | 37 | 5.874 | 77 | 1.291 | 117 | 0.3899 |
| -2 | 39.82 | 38 | 5.630 | 78 | 1.254 | 118 | 0.3796 |
| -1 | 37.20 | 39 | 5.397 | 79 | 1.2133 | 119 | 0.3695 |
| 0 | 35.20 | 40 | 5.175 | 80 | 1.174 | 120 | 0.3598 |
| 1 | 33.33 | 41 | 4.964 | 81 | 1.136 | 121 | 0.3504 |
| 2 | 31.56 | 42 | 4.763 | 82 | 1.100 | 122 | 0.3413 |
| 3 | 29.91 | 43 | 4.571 | 83 | 1.064 | 123 | 0.3325 |
| 4 | 28.35 | 44 | 4.387 | 84 | 1.031 | 124 | 0.3239 |
| 5 | 26.88 | 45 | 4.213 | 85 | 0.9982 | 125 | 0.3156 |
| 6 | 25.50 | 46 | 4.046 | 86 | 0.9668 | 126 | 0.3075 |
| 7 | 24.19 | 47 | 3.887 | 87 | 0.9366 | 127 | 0.2997 |
| 8 | 22.57 | 48 | 3.735 | 88 | 0.9075 | 128 | 0.2922 |
| 9 | 21.81 | 49 | 3.590 | 89 | 0.8795 | 129 | 0.2848 |
| 10 | 20.72 | 50 | 3.451 | 90 | 0.8525 | 130 | 0.2777 |
| 11 | 19.69 | 51 | 3.318 | 91 | 0.8264 | 131 | 0.2708 |
| 12 | 18.72 | 52 | 3.192 | 92 | 0.8013 | 132 | 0.2641 |
| 13 | 17.80 | 53 | 3.071 | 93 | 0.7771 | 133 | 0.2576 |
| 14 | 16.93 | 54 | 2.959 | 94 | 0.7537 | 134 | 0.2513 |
| 15 | 16.12 | 55 | 2.844 | 95 | 0.7312 | 135 | 0.2451 |
| 16 | 15.34 | 56 | 2.738 | 96 | 0.7094 | 136 | 0.2392 |
| 17 | 14.62 | 57 | 2.637 | 97 | 0.6884 | 137 | 0.2334 |
| 18 | 13.92 | 58 | 2.540 | 98 | 0.6682 | 138 | 0.2278 |
| 19 | 13.26 | 59 | 2.447 | 99 | 0.6486 | 139 | 0.2223 |

Table 6-3.2: Compressor discharge pipe temperature sensor resistance characteristics

| Temperature (°C) | Resistance (kΩ) | Temperature (°C) | Resistance (kΩ) | Temperature (°C) | Resistance (kΩ) | Temperature (°C) | Resistance (kΩ) |
|------------------|-----------------|------------------|-----------------|------------------|-----------------|------------------|-----------------|
| -30 | 913.239 | 16 | 83.541 | 62 | 12.809 | 108 | 2.918 |
| -29 | 862.001 | 17 | 79.801 | 63 | 12.357 | 109 | 2.835 |
| -28 | 813.806 | 18 | 76.248 | 64 | 11.923 | 110 | 2.755 |
| -27 | 768.47 | 19 | 72.871 | 65 | 11.506 | 111 | 2.678 |
| -26 | 725.821 | 20 | 69.66 | 66 | 11.105 | 112 | 2.603 |
| -25 | 685.694 | 21 | 66.607 | 67 | 10.721 | 113 | 2.53 |
| -24 | 647.937 | 22 | 63.703 | 68 | 10.352 | 114 | 2.46 |
| -23 | 612.405 | 23 | 60.939 | 69 | 9.997 | 115 | 2.392 |
| -22 | 578.963 | 24 | 58.31 | 70 | 9.656 | 116 | 2.326 |
| -21 | 547.482 | 25 | 55.807 | 71 | 9.329 | 117 | 2.262 |
| -20 | 517.845 | 26 | 53.424 | 72 | 9.014 | 118 | 2.2 |
| -19 | 489.937 | 27 | 51.154 | 73 | 8.711 | 119 | 2.141 |
| -18 | 463.653 | 28 | 48.992 | 74 | 8.42 | 120 | 2.082 |
| -17 | 438.895 | 29 | 46.933 | 75 | 8.14 | 121 | 2.026 |
| -16 | 415.569 | 30 | 44.97 | 76 | 7.871 | 122 | 1.972 |
| -15 | 393.587 | 31 | 43.098 | 77 | 7.612 | 123 | 1.919 |
| -14 | 372.869 | 32 | 41.314 | 78 | 7.363 | 124 | 1.868 |
| -13 | 353.337 | 33 | 39.613 | 79 | 7.123 | 125 | 1.818 |
| -12 | 334.92 | 34 | 37.989 | 80 | 6.892 | 126 | 1.77 |
| -11 | 317.549 | 35 | 36.441 | 81 | 6.67 | 127 | 1.723 |
| -10 | 301.161 | 36 | 34.963 | 82 | 6.456 | 128 | 1.678 |
| -9 | 285.699 | 37 | 33.552 | 83 | 6.249 | 129 | 1.635 |
| -8 | 271.104 | 38 | 32.205 | 84 | 6.051 | 130 | 1.592 |
| -7 | 257.326 | 39 | 30.919 | 85 | 5.859 | 131 | 1.551 |
| -6 | 244.316 | 40 | 29.691 | 86 | 5.675 | 132 | 1.511 |
| -5 | 232.028 | 41 | 28.517 | 87 | 5.497 | 133 | 1.472 |
| -4 | 220.418 | 42 | 27.395 | 88 | 5.325 | 134 | 1.435 |
| -3 | 209.447 | 43 | 26.323 | 89 | 5.16 | 135 | 1.399 |
| -2 | 199.077 | 44 | 25.298 | 90 | 5 | 136 | 1.363 |
| -1 | 189.272 | 45 | 24.318 | 91 | 4.846 | 137 | 1.329 |
| 0 | 179.999 | 46 | 23.381 | 92 | 4.697 | 138 | 1.296 |
| 1 | 171.227 | 47 | 22.485 | 93 | 4.554 | 139 | 1.264 |
| 2 | 162.926 | 48 | 21.627 | 94 | 4.415 | 140 | 1.233 |
| 3 | 155.07 | 49 | 20.806 | 95 | 4.282 | 141 | 1.203 |
| 4 | 147.632 | 50 | 20.021 | 96 | 4.152 | 142 | 1.174 |
| 5 | 140.589 | 51 | 19.269 | 97 | 4.027 | 143 | 1.146 |
| 6 | 133.917 | 52 | 18.548 | 98 | 3.907 | 144 | 1.119 |
| 7 | 127.596 | 53 | 17.859 | 99 | 3.79 | 145 | 1.093 |
| 8 | 121.605 | 54 | 17.198 | 100 | 3.677 | 146 | 1.067 |
| 9 | 115.926 | 55 | 16.565 | 101 | 3.568 | 147 | 1.043 |
| 10 | 110.54 | 56 | 15.958 | 102 | 3.463 | 148 | 1.019 |
| 11 | 105.433 | 57 | 15.377 | 103 | 3.361 | 149 | 0.996 |
| 12 | 100.587 | 58 | 14.82 | 104 | 3.262 | 150 | 0.974 |
| 13 | 95.988 | 59 | 14.285 | 105 | 3.166 | | |
| 14 | 91.622 | 60 | 13.773 | 106 | 3.091 | | |
| 15 | 87.477 | 61 | 13.281 | 107 | 3.003 | | |

Table 6-3.3: Heat sink temperature sensor resistance characteristics

| Temperature (°C) | Resistance (kΩ) | Temperature (°C) | Resistance (kΩ) | Temperature (°C) | Resistance (kΩ) | Temperature (°C) | Resistance (kΩ) |
|------------------|-----------------|------------------|-----------------|------------------|-----------------|------------------|-----------------|
| -30 | 971.4 | 10 | 109.0 | 50 | 19.70 | 90 | 5.000 |
| -29 | 912.8 | 11 | 103.9 | 51 | 18.97 | 91 | 4.855 |
| -28 | 858.2 | 12 | 99.02 | 52 | 18.26 | 92 | 4.705 |
| -27 | 807.3 | 13 | 94.44 | 53 | 17.59 | 93 | 4.566 |
| -26 | 759.7 | 14 | 90.11 | 54 | 16.94 | 94 | 4.431 |
| -25 | 715.3 | 15 | 86.00 | 55 | 16.32 | 95 | 4.301 |
| -24 | 673.6 | 16 | 82.09 | 56 | 15.73 | 96 | 4.176 |
| -23 | 634.7 | 17 | 78.38 | 57 | 15.16 | 97 | 4.055 |
| -22 | 598.2 | 18 | 74.87 | 58 | 14.62 | 98 | 3.938 |
| -21 | 564.1 | 19 | 71.53 | 59 | 14.10 | 99 | 3.825 |
| -20 | 532.2 | 20 | 68.36 | 60 | 13.60 | 100 | 3.716 |
| -19 | 502.2 | 21 | 65.34 | 61 | 13.12 | 101 | 3.613 |
| -18 | 474.1 | 22 | 62.47 | 62 | 12.65 | 102 | 3.514 |
| -17 | 447.7 | 23 | 59.75 | 63 | 12.22 | 103 | 3.418 |
| -16 | 423.0 | 24 | 57.17 | 64 | 11.79 | 104 | 3.326 |
| -15 | 399.8 | 25 | 54.71 | 65 | 11.39 | 105 | 3.235 |
| -14 | 378.0 | 26 | 52.36 | 66 | 10.99 | 106 | 3.148 |
| -13 | 357.5 | 27 | 50.13 | 67 | 10.62 | 107 | 3.063 |
| -12 | 338.2 | 28 | 48.01 | 68 | 10.25 | 108 | 2.982 |
| -11 | 320.1 | 29 | 45.99 | 69 | 9.909 | 109 | 2.902 |
| -10 | 303.1 | 30 | 44.07 | 70 | 9.576 | 110 | 2.826 |
| -9 | 287.1 | 31 | 42.23 | 71 | 9.253 | 111 | 2.747 |
| -8 | 272.0 | 32 | 40.48 | 72 | 8.947 | 112 | 2.672 |
| -7 | 257.8 | 33 | 38.81 | 73 | 8.646 | 113 | 2.599 |
| -6 | 244.4 | 34 | 37.23 | 74 | 8.362 | 114 | 2.528 |
| -5 | 231.9 | 35 | 35.71 | 75 | 8.089 | 115 | 2.460 |
| -4 | 220.0 | 36 | 34.27 | 76 | 7.821 | 116 | 2.390 |
| -3 | 208.7 | 37 | 32.89 | 77 | 7.569 | 117 | 2.322 |
| -2 | 198.2 | 38 | 31.58 | 78 | 7.323 | 118 | 2.256 |
| -1 | 188.2 | 39 | 30.33 | 79 | 7.088 | 119 | 2.193 |
| 0 | 178.8 | 40 | 29.13 | 80 | 6.858 | 120 | 2.132 |
| 1 | 169.9 | 41 | 27.98 | 81 | 6.640 | 121 | 2.073 |
| 2 | 161.5 | 42 | 26.89 | 82 | 6.432 | 122 | 2.017 |
| 3 | 153.6 | 43 | 25.85 | 83 | 6.230 | 123 | 1.962 |
| 4 | 146.1 | 44 | 24.85 | 84 | 6.033 | 124 | 1.910 |
| 5 | 139.1 | 45 | 23.90 | 85 | 5.847 | 125 | 1.859 |
| 6 | 132.3 | 46 | 22.98 | 86 | 5.667 | | |
| 7 | 126.0 | 47 | 22.10 | 87 | 5.492 | | |
| 8 | 120.0 | 48 | 21.26 | 88 | 5.322 | | |
| 9 | 114.3 | 49 | 20.47 | 89 | 5.159 | | |

Quantum Series (AU)



3.2 Normal Operating Parameters of Refrigerant System

Under the following conditions, the operating parameters given in Tables 6-3.4 and 6-3.5 should be observed:

- The outdoor unit can detect all the indoor units.
- The number of indoor units displayed on DSP is steady and is equal to the actual number of indoor units installed.
- All stop valves are open and all indoor unit EXVs are connected to their unit's PCB.
- All the indoor units are currently running.
- If the outdoor ambient temperature is high, the system is being run in cooling mode with the following settings: temperature 17°C; fan speed high.
- If the outdoor ambient temperature is low, the system is being run in heating mode with the following settings: temperature 30°C; fan speed high.
- The system has been running normally for more than 30 minutes.

Table 6-3.4: Outdoor unit cooling mode operating parameters

| Outdoor ambient temperature | °C | < 10 | 10 to 26 | 26 to 31 | 31 to 41 | > 41 |
|--------------------------------|-----|---------|----------|----------|----------|---------|
| Average discharge temperature | °C | 60-76 | 62-78 | 65-82 | 67-92 | 69-92 |
| Average discharge superheat | °C | 17-30 | 17-33 | 17-34 | 17-36 | 10-32 |
| Discharge pressure | MPa | 2.3-2.8 | 2.3-2.8 | 2.4-3.6 | 2.6-3.8 | 3.1-4.2 |
| Suction pressure | MPa | 0.6-0.7 | 0.7-0.9 | 0.8-1.0 | 1.0-1.2 | 1.2-1.4 |
| DC inverter compressor current | A | 7-18 | 10-20 | 12-25 | 15-27 | 18-25 |

Table 6-3.5: Outdoor unit heating mode operating parameters

| Outdoor ambient temperature | °C | < -10 | -10 to 0 | 0 to 5 | 5 to 10 | 10 to 17 | > 17 |
|--------------------------------|-----|---------|----------|---------|---------|----------|---------|
| Average discharge temperature | °C | 56-74 | 57-76 | 58-78 | 61-82 | 63-82 | 63-82 |
| Average discharge superheat | °C | 17-35 | 17-35 | 17-35 | 17-33 | 14-33 | 14-33 |
| Discharge pressure | MPa | 1.7-2.4 | 1.8-2.5 | 1.9-3.0 | 2.2-3.2 | 2.3-3.2 | 2.3-3.2 |
| Suction pressure | MPa | 1.4-1.6 | 1.5-1.7 | 1.6-2.2 | 1.8-2.6 | 1.8-2.6 | 2.0-2.4 |
| DC inverter compressor current | A | 11-23 | 12-25 | 10-25 | 10-26 | 10-22 | 13-20 |

Part 7

Indoor Unit Diagnosis and Troubleshooting

| | |
|-----------------------------------|-----|
| 1 Errors and operation code | 120 |
| 2 Troubleshooting | 123 |
| 3 Appendix..... | 193 |

1 Errors and operation code Error Code Table

Table 7.1: Error code

| Error code | Content | Error code | Content |
|------------|--|------------|---|
| A01 | Emergency stop | C52 | Abnormal communication between the IDU and Wi-Fi Kit |
| A11 | R32 refrigerant leaks, requiring shutdown immediately | C61 | Abnormal communication between the IDU main control board and display board |
| A51 | Outdoor unit fault | C71 | Abnormal communication between the AHU Kit slave unit and master unit |
| A71 | Interlocking control Heat Recovery Ventilation Unit fault (in-series application) | C72 | Number of AHU Kits is not the same as the set number |
| A72 | The Humidity Unit fault | C73 | Abnormal communication between the linked humidifying IDU and master IDU |
| A73 | Interlocking control Heat Recovery Ventilation Unit fault (non-serial application) | C74 | Abnormal communication between the linked FAPU and master IDU (series setting) |
| A74 | The AHU Kit slave unit fault | C75 | Abnormal communication between the linked FAPU and master IDU (non-series setting) |
| A81 | Self-check fault | C76 | Abnormal communication between the main wired controller and secondary wired controller |
| A82 | MS (refrigerant flow direction switching device) fault | C77 | Abnormal communication between the IDU main control board and 1# Expansion board |
| A91 | Mode conflict | C78 | Abnormal communication between the IDU main control board and 2# Expansion board |
| b11 | 1# EEV coil fault | C79 | Abnormal communication between the IDU main control board and Switch module |
| b12 | 1# EEV body fault | C81 | The indoor unit is in a power-off state |
| b13 | 2# EEV coil fault | d16 | Air inlet temperature of the IDU is too low in heating mode |
| b14 | 2# EEV body fault | d17 | Air inlet temperature of the IDU is too high in cooling mode |
| b34 | Protection on 1# water pump | d81 | Alarm for exceeding temperature and humidity range |
| b35 | Protection on 2# water pump | dE1 | Sensor control board fault |
| b36 | Water level switch alarm | dE2 | PM2.5 sensor fault |
| b71 | Reheating electric heater fault | dE3 | CO2 sensor fault |
| b72 | Preprocessing electric heater fault | dE4 | Formaldehyde sensor fault |
| b81 | Humidifier fault | dE5 | Human Detect sensor fault |
| C11 | Duplicate IDU address code | E21 | T0 (fresh inlet air temperature sensor) short-circuits or cuts off |
| C21 | Abnormal communication between the IDU and ODU | E22 | The upper dry bulb temperature sensor short-circuits or cuts off |
| C41 | Abnormal communication between the IDU main control board and fan drive board | E23 | The lower dry bulb temperature sensor short-circuits or cuts off |
| C51 | Abnormal communication between the IDU and wired controller | E24 | T1 (IDU return air temperature sensor) short-circuits or cuts off |

Table 7.1: Error code (continued)

| Error code | Content | Error code | Content |
|------------|--|------------|---|
| E31 | wired controller temperature sensor failure | U01 | Locked (electronic lock) |
| E32 | The wireless temperature sensor short-circuits or cuts off | U11 | Unit model code not set |
| E33 | The external room temperature sensor short-circuits or cuts off | U12 | Capacity(HP) code not set |
| E61 | Tcp (pre-cooled fresh air temperature sensor) short-circuits or cuts off | U14 | The capacity value of the AHU Kit DIP switch does not match the model |
| E62 | Tph (pre-heated fresh air temperature sensor) short-circuits or cuts off | U15 | The DIP value of AHU Kit's fan speed output voltage is incorrect |
| E81 | TA (outlet air temperature sensor) short-circuits or cuts off | U26 | Mismatch between indoor unit model and outdoor unit model |
| EA1 | Outlet air humidity sensor fault | U38 | Address code not detected |
| EA2 | Return air humidity sensor fault | J01 | Motor failed more than once |
| EA3 | Upper wet bulb sensor fault | J1E | IPM (fan module) overcurrent protection |
| EA4 | Lower wet bulb sensor fault | J11 | Instantaneous overcurrent protection for phase current |
| EC1 | R32 refrigerant leakage sensor fault | J3E | Low bus voltage fault |
| F01 | T2A (heat exchanger liquid pipe temperature sensor) short-circuits or cuts off | J31 | High bus voltage fault |
| F11 | T2 (heat exchanger middle temperature sensor) short-circuits or cuts off | J43 | Phase current sample bias error |
| F12 | T2 (heat exchanger middle temperature sensor) over temperature protection | J45 | Motor and IDU are unmatched |
| F21 | T2B (heat exchanger gas pipe temperature sensor) short-circuits or cuts off | J47 | IPM and IDU are unmatched |
| P71 | Main control board EEPROM fault | J5E | Motor startup failure |
| P72 | IDU display control board EEPROM fault | J52 | Motor blocking protection |
| P31/P34 | Fan drive board AC side overcurrent protection | J55 | Speed control mode setting error |
| P52 | The voltage of the power supply is too low | J6E | Phase lack protection of motor |

1.1 Operating Status Codes

Table 7.2: Operating Status Codes

| Code | Content | Code | Content |
|------|------------------------------------|------|----------------------------------|
| d0 | Oil return or preheating operation | d61 | Remote shutdown |
| dC | Self-cleaning | d71 | IDU backup operation |
| dd | Mode conflict | d72 | ODU backup operation |
| dF | Defrosting | OTA | Main control program upgrading |
| d51 | Initial static pressure detection | dH | Hot water mode (Specific series) |

2 Troubleshooting

Warning



- All electrical work must be carried out by competent and suitably qualified, certified and accredited professionals and in accordance with all applicable legislation (all national, local and other laws, standards, codes, rules, regulations and other legislation that apply in a given situation).
- Power-off the unit before connecting or disconnecting any connections or wiring, otherwise electric shock (which can cause physical injury or death) may occur or damage to components may occur.

2.1 A01 – Emergency shutdown

| | | |
|-----------------|---|--|
| Error display | Digital display | Display position |
| | | Panel, display box, and wired controller |
| Error impact | The faulty IDU and other IDUs of the same system: stop running, displaying code "A01" (V6 platform indoor unit displays "A0" code) | |
| | ODU of the same system: stop running, displaying code "A01" (V6 platform outdoor unit displays "A0" code) | |
| Error trigger | When the IDU receives an emergency shutdown signal from the ODU | |
| Error recovery | After troubleshooting, power on again | |
| Possible cause | <ul style="list-style-type: none"> ■ An emergency shutdown signal is received. ■ The IDU main control board is damaged. | |
| Troubleshooting | <div style="text-align: center;"> <pre> graph TD Start([A01]) --> Step1[Find out the cause of the emergency shutdown and solve it before clearing the emergency shutdown signal] Step1 --> Decision{Check whether the fault is cleared} Decision -- No --> Step2[Replace the main control board of the IDU] Decision -- Yes --> Step3[Fault cleared] </pre> </div> <p>Note:</p> <p>1. Emergency shutdown is usually caused by the outdoor unit receiving an emergency shutdown command sent by the central controller or external reasons. For detailed handling instructions, please refer to the corresponding outdoor unit troubleshooting manual.</p> | |

2.2 A11 - R32 refrigerant leaks, requiring shutdown immediately

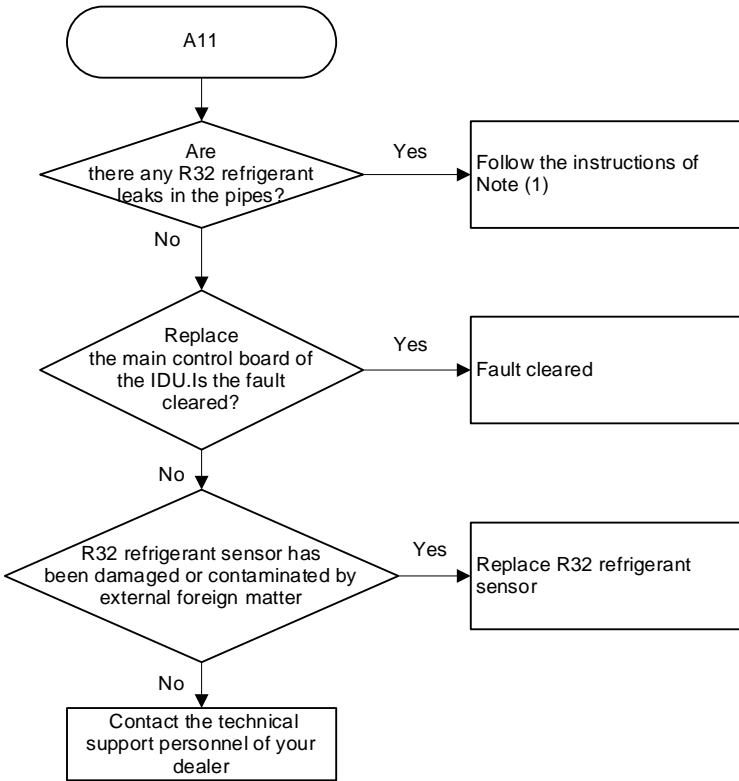
| Error display | Digital display | Display position |
|-----------------|--|--|
| |  | Panel, display box, and wired controller |
| Error impact | <ul style="list-style-type: none"> ■ Faulty IDU: The fan operates at the highest speed, the EEV is closed (Note: Fault persists after power on again), and buzzer of the display control board of the faulty IDU and buzzer of wired controller connected to the faulty IDU keep beeping. ■ Other IDUs of the same system: Refrigerant is recycled to ODU. After recycling is completed, other IDUs stop running, displaying code "A51" - ODU fault <p>ODU of the same system: It stops running after recycling is completed, displaying code "A11" - IDU refrigerant leaks.</p> | |
| Error trigger | When the IDU main control board receives a refrigerant leakage signal from R32 refrigerant detection device (See Figure 1 below) or the abnormal communication among the IDU main control board, the adapter board and the control board of the R32 refrigerant detection device causes the fault to trigger by mistake. | |
| Error recovery | Has not detected the refrigerant leak signal and has received the signal of refrigerant fault rectification | |
| Possible cause | <ul style="list-style-type: none"> ■ R32 refrigerant of IDUs leaks. ■ R32 refrigerant sensor is damaged or contaminated with external foreign matter (e.g. steam, oil) ■ Abnormal communication among IDU main control board, adapter board and R32 refrigerant detection device control board ■ IDU main control board or adapter board or R32 refrigerant detection device control board damaged | |
| Troubleshooting | <div style="text-align: center;">  <pre> graph TD Start([A11]) --> D1{Are there any R32 refrigerant leaks in the pipes?} D1 -- Yes --> N1[Follow the instructions of Note (1)] D1 -- No --> D2{Replace the main control board of the IDU. Is the fault cleared?} D2 -- Yes --> E1[Fault cleared] D2 -- No --> D3{R32 refrigerant sensor has been damaged or contaminated by external foreign matter} D3 -- Yes --> E2[Replace R32 refrigerant sensor] D3 -- No --> E3[Contact the technical support personnel of your dealer] </pre> </div> <p>Note 1: Adapter board ENC1 dip switch setting When the function of determining refrigerant leakage fault is effective, if the communication abnormality between indoor unit main control board, adapter board and R32 refrigerant detection device control board lasts for more than 2 minutes (see "C79" fault handling in this manual for the communication abnormality handling method between indoor unit main control board and adapter board, and</p> | |

see R32 refrigerant detection device control board operation and installation manual for the communication abnormality handling method between adapter board and R32 refrigerant detection device control board), "A11" fault will be triggered by mistake.

Note 2:

Step 1: Refrigerant leakage inspection method and refrigerant leakage treatment

(1) Check whether there is refrigerant leakage in the field pipeline. Inspection method: if the system is connected with the refrigerant block device, use the refrigerant pressure gauge to connect the liquid test or gas test maintenance needle valve of the refrigerant block device; if the system is not connected with the refrigerant block device, use the refrigerant pressure gauge to connect the liquid test or gas test maintenance needle valve of the outdoor unit. Measure the refrigerant saturation gauge pressure in the field pipeline. If the measured liquid side or gas side refrigerant saturation pressure is less than the standard saturation pressure (see the table of R32 refrigerant ambient temperature and standard saturation gauge pressure in the attached table of this manual), it is determined that there is refrigerant leakage. Follow these steps to handle refrigerant leaks:

- As shown in the figure below, use the refrigerant recovery device to recover the refrigerant in Part 1 and Part 2 respectively. Note: 1) The recovery device must be connected to the liquid/gas side needle valve at the same time to ensure that the residual refrigerant in the liquid pipe and the air pipe is recovered completely; 2) For the recovery of Part 1, it is necessary to enter the outdoor unit engineering menu and select the vacuumizing mode to ensure that all valve bodies of the outdoor unit are in the open state.

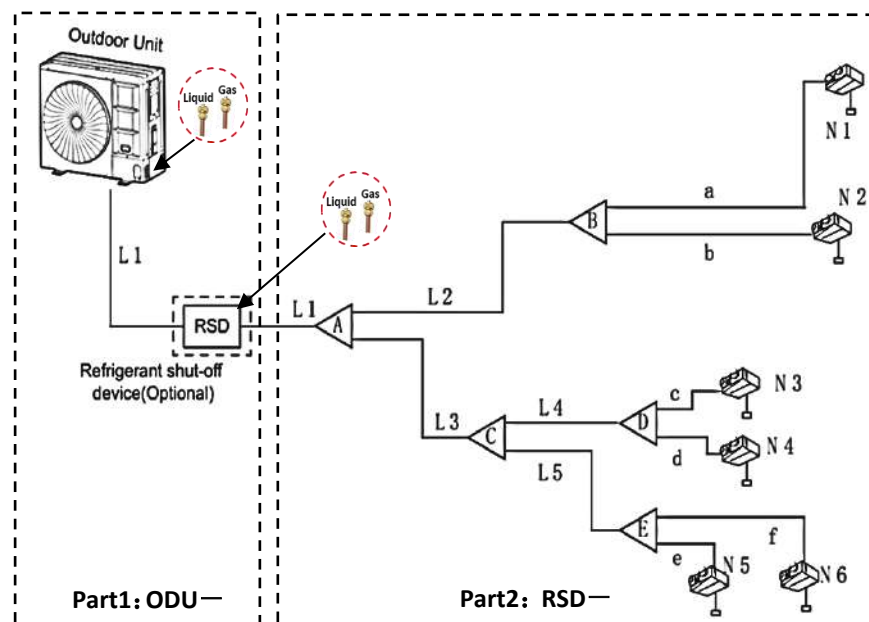

- Locate and repair pipeline leaks.
- After the repair is completed, the system is tested for gas tightness, refer to the Owner's and installation manual for details. If the gas tightness test is passed, go to the next step, otherwise repeat the step above until the gas tightness test is passed
- Replace the R32 sensor model of the faulty IDU.
- Recharge refrigerant according to the ODU Installation Manual.

(2) If the measured refrigerant saturation pressure on the liquid side or gas side is equal to the standard saturation pressure (see Table of Ambient Temperature and Standard Saturation Pressure of R32 attached to this manual), confirm whether there is a refrigerant leak by using refrigerant testing instruments. If it is determined that there is a refrigerant leak, please operate the refrigerant leak handling procedure above.

Step 2: Reset the R32 refrigerant detection device.

Refer to Figure 1 below. After the refrigerant leakage alarm, the red LED (LED 2) in the R32 refrigerant detection device lights up once every 1s, and the buzzer sounds once every 1s. After maintenance, press and hold the S1 key on the control panel for 10s to reset. After resetting, all LEDs are on for 2S and then go out, and the buzzer stops ringing. The R32 sensor life timing recorded by EERPOM on the control panel is cleared.

Step 3: Wired controller reset operation.

When the wired controller receives the refrigerant leakage fault command transmitted by the indoor unit, the interface will display the "A11" code, and the buzzer will sound once every 1s. After the above step 1/2 is completed and the R32 refrigerant leakage alarm signal is OFF, enter the wired controller engineering parameter setting menu to select the parameter: refrigerant leakage fault reset. After the reset is completed, the interface will no longer display the "A11" code, and the buzzer stops ringing. Note: If the R32 refrigerant leakage alarm signal = ON, the reset operation is invalid!

Figure 1 Schematic diagram of the R32 refrigerant leakage detection system

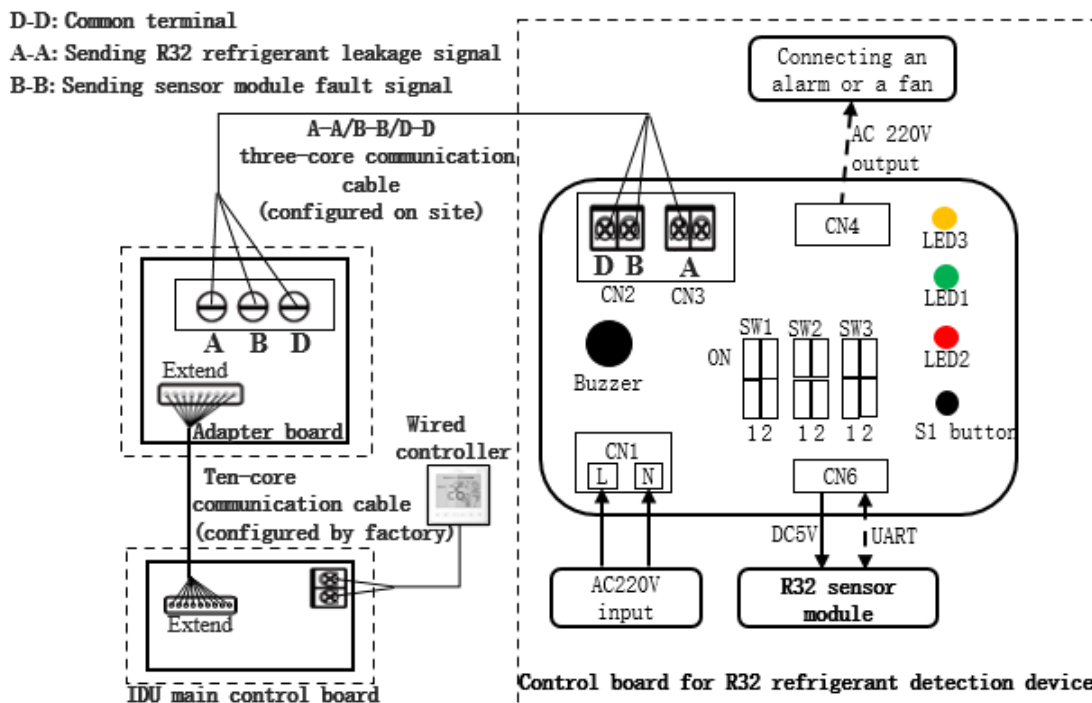

Note: The A/B/D wet printed numbers on the adapter board and the R32 refrigerant detection device control board are only used for the connection of the communication line. Please refer to the corresponding requirements in the installation instructions of the adapter board and the R32 refrigerant detection device control board when connecting the communication line on site.

2.3 A51 - ODU fault

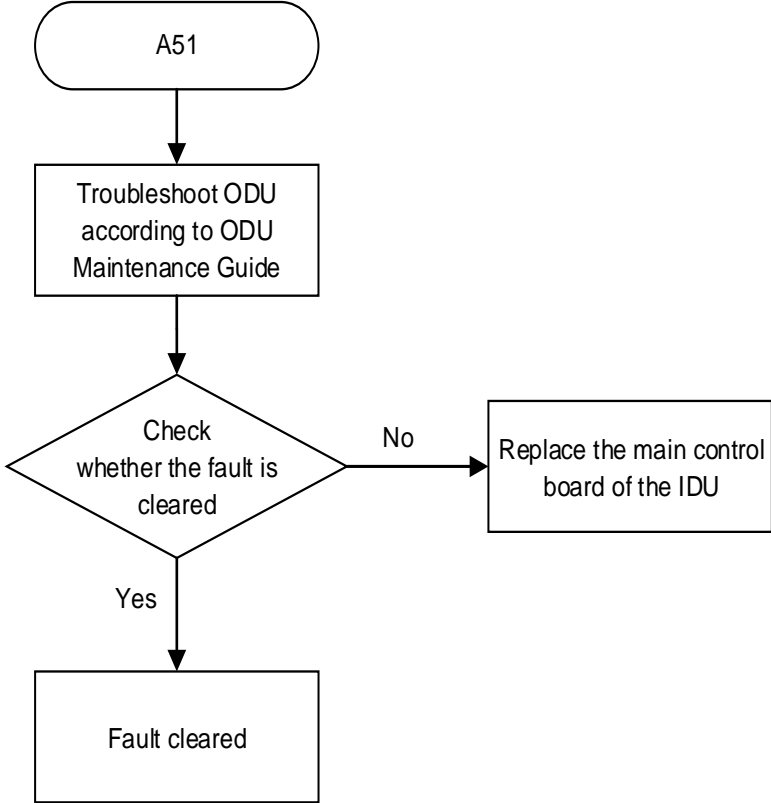
| | | |
|-----------------|--|--|
| Error display | Digital display | Display position |
| |  | Panel, display box, and wired controller |
| Error impact | <p>The faulty IDU and other IDUs of the same system: The fan continues running, the EEV is closed, and code "A51" is displayed (V6 platform IDU displays the code "Ed")</p> <p>ODU of the same system:</p> <ul style="list-style-type: none"> ■ stops. ■ The displayed code depends on the error type of the ODU. For the meaning of the code, please refer to the error table specific to the model of the ODU. | |
| Error trigger | Duration of ODU error ≥ 10 minutes | |
| Error recovery | Automatic recovery | |
| Possible cause | <ul style="list-style-type: none"> ■ The ODU error is transmitted to the IDU. ■ The IDU main control board is damaged. | |
| Troubleshooting |  <pre> graph TD A51([A51]) --> B[Troubleshoot ODU according to ODU Maintenance Guide] B --> C{Check whether the fault is cleared} C -- Yes --> D[Fault cleared] C -- No --> E[Replace the main control board of the IDU] </pre> | |

2.4 A71 - The error of the linked FAPU is transmitted to the master IDU (series setting)

- Note:
- 1) The type of FAPU may be HRV, VRF fresh air IDU and so on.
 - 2) Series setting: The air supply side of the linked FAPU is directly connected to the air return side of the master IDU through an air duct. A wired controller is used to set this installation method as a series connection.

| | | |
|-----------------------|--|--|
| Error display | Digital display | Display position (master IDU) |
| | | Panel, display box, and wired controller |
| Error impact | The master IDU and the linked FAPU: stop. Other IDUs of the same system: operate normally. | |
| | ODU of the same system: operate normally. | |
| Error trigger | The error of the linked FAPU is transmitted to the master IDU | |
| Error recovery | Automatic recovery | |
| Possible cause | <ul style="list-style-type: none"> ■ The FAPU is faulty. ■ The master IDU's main control board is damaged. | |

| | |
|------------------------|---|
| Troubleshooting | <pre> graph TD Start([A71/A73]) --> Step1[Obtain the linked error code (1) of the FAPU, and refer to the corresponding error handling method in the maintenance manual of the FAPU for troubleshooting] Step1 --> Decision{Error in FAPU After troubleshooting, is the master IDU error code cleared?} Decision -- Yes --> End1[Fault cleared] Decision -- No --> End2[Replace the the main control board of the master IDU] </pre> |
| | <p>Note:</p> <ol style="list-style-type: none"> 1. The error code can be queried after the FAPU is connected to the wired controller or the display box. |

2.5 A72 - The error of the linked humidifying IDU is transmitted to the master IDU

| | | | |
|----------------|--|-------------------------------|-----------------------------|
| Error display | Digital display | Display position (master IDU) | |
| | | Panel or display box | Wired controller |
| | | Spot check interface query | Error code is not displayed |
| Error impact | Master IDU: operates normally. Humidifying IDUs: stop. Other IDUs of the same system: operate normally. ODU of the same system: operate normally. | | |
| Error trigger | The error of the linked humidifying IDU is transmitted to the master IDU | | |
| Error recovery | Automatic recovery | | |
| Possible cause | <ul style="list-style-type: none"> ■ The humidifying IDU is faulty. ■ The master IDU's main control board is damaged. | | |

Troubleshooting

```

graph TD
    Start([A72]) --> Step1[Obtain the linked error code (1) of the humidifying IDU, and refer to the corresponding error handling method in the maintenance manual of the humidifying IDU for troubleshooting]
    Step1 --> Decision{Error in humidifying IDU  
After troubleshooting, is the master IDU error code cleared?}
    Decision -- Yes --> End([Fault cleared])
    Decision -- No --> Step2[Replace the the main control board of the master IDU]
    
```

Note:

1. The error code can be queried after the humidifying IDU is connected to the wired controller or the display box.

2.6 A73 - The error of the linked FAPU is transmitted to the master IDU (non-series connection)

Note:

- 1) The type of FAPU may be HRV, VRF fresh air IDU and so on.
- 2) Series setting: The linked FAPU and the master IDU are connected to the air supply duct and air return duct respectively and separately. A wired controller is used to set this installation method as a non-series connection.

| | | | |
|------------------------|--|-------------------------------|-----------------------------|
| Error display | Digital display | Display position (master IDU) | |
| | | Panel or display box | Wired controller |
| | | Spot check interface query | Error code is not displayed |
| Error impact | Master IDU: operates normally. FAPU: stops. Other IDUs of the same system: operate normally. ODU of the same system: operate normally. | | |
| Error trigger | The error of the linked FAPU is transmitted to the master IDU | | |
| Error recovery | Automatic recovery | | |
| Possible cause | <ul style="list-style-type: none"> ■ The FAPU is faulty. ■ The master IDU's main control board is damaged. | | |
| Troubleshooting | <div style="text-align: center;"> <pre> graph TD Start([A71/A73]) --> Step1[Obtain the linked error code (1) of the FAPU, and refer to the corresponding error handling method in the maintenance manual of the FAPU for troubleshooting] Step1 --> Decision{Error in FAPU After troubleshooting, is the master IDU error code cleared?} Decision -- Yes --> End1[Fault cleared] Decision -- No --> End2[Replace the the main control board of the master IDU] </pre> </div> <p>Note:</p> <ol style="list-style-type: none"> 1. The error code can be queried after the FAPU is connected to the wired controller or the display box. | | |

2.7 A81 - Self-check fault

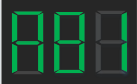
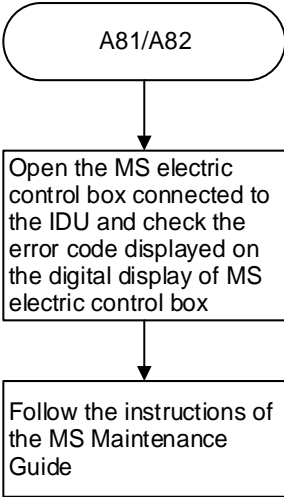
| | Digital display | Display position |
|------------------------|---|--|
| Error display |  | Panel, display box, and wired controller |
| Error impact | Faulty IDU: stops. Other IDUs of the same system: <ul style="list-style-type: none"> ■ IDUs that share the same MS with the faulty IDU will stop operating, while other IDUs remain in operation. ■ IDUs that share the same MS with the faulty IDU display the code "A81" (V6 platform IDU displays the code "U4"). Meaning of the code: MS self-check fault); IDUs that are connected to other MSs work properly. | |
| | ODU of the same system: <ul style="list-style-type: none"> ■ stops. ■ V8 platform ODU displays the code "A81", and V6 platform ODU displays the code "U4". Meaning of the code: MS self-check fault) | |
| Error trigger | The MS self-check fault lasts for at least 10 min | |
| Error recovery | The fault is cleared if one of the following conditions is met: <ul style="list-style-type: none"> ■ Automatic recovery 30 min after the MS fault is cleared ■ Power on again | |
| Possible cause | <ul style="list-style-type: none"> ■ A fault may occur during the MS self-check process. | |
| Troubleshooting |  <pre> graph TD A81[A81/A82] --> B[Open the MS electric control box connected to the IDU and check the error code displayed on the digital display of MS electric control box] B --> C[Follow the instructions of the MS Maintenance Guide] </pre> | |

2.8 A82 - MS (refrigerant flow direction switching device) fault

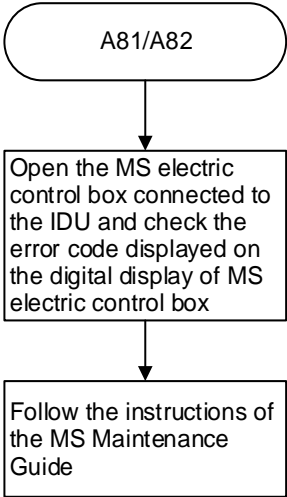
| | | |
|------------------------|---|--|
| Faulty IDU | Digital display | Display position |
| |  | Panel, display box, and wired controller |
| Error impact | Faulty IDU: The fan continues running, and the EEV is closed. Other IDUs of the same system: <ul style="list-style-type: none"> ■ IDUs that share the same MS with the faulty IDU: The fan continues running, and the EEV is closed. Other IDUs remain in operation. ■ IDUs that share the same MS with the faulty IDU: V8 platform IDU displays the code "A82", and V6 platform IDU displays the code "F8". Meaning of the code: MS fault. IDUs that are connected to other MSs work properly. | |
| | ODU of the same system: <ul style="list-style-type: none"> ■ Shutdown ■ V8 platform ODU displays the code "A82" (V6 platform ODU displays the code "F8". Meaning of the code: MS fault) | |
| Error trigger | When the IDU receives a fault signal from MS | |
| Error recovery | Automatic recovery (Note: Duration from fault triggering to automatic recovery is at least 30 min) | |
| Possible cause | The MS is faulty. | |
| Troubleshooting |  <pre> graph TD A81/A82([A81/A82]) --> B[Open the MS electric control box connected to the IDU and check the error code displayed on the digital display of MS electric control box] B --> C[Follow the instructions of the MS Maintenance Guide] </pre> | |

Quantum Series (AU)



2.9 A91 - Mode conflict (V6 communication protocol adopted)

Available when using V6 platform wired controller.

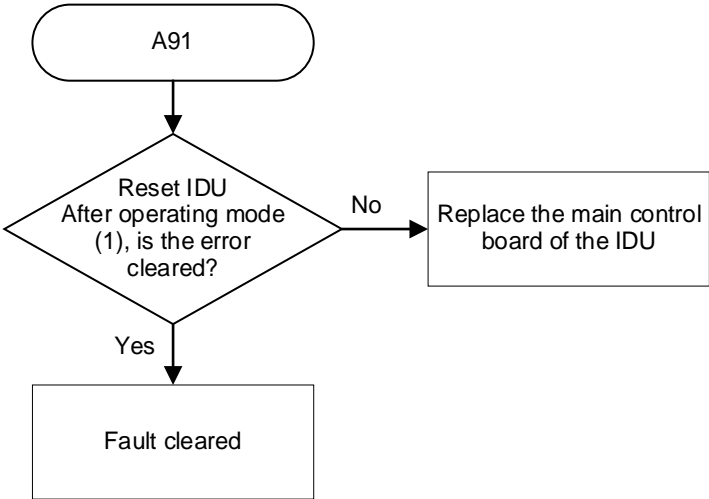
| Error display | Digital display | Display position |
|-----------------|---|--|
| |  | Panel, display box, and wired controller (Note: Error codes are displayed 2 minutes after faults are triggered) |
| Error impact | Faulty IDU: The fan continues running, and the EEV is closed. Other IDUs of the same system: operate normally. ODU of the same system: operate normally. | |
| Error trigger | <ul style="list-style-type: none"> ■ The ODU is running in heating mode, and the IDU is running in cooling mode or dehumidification mode. ■ The ODU is running in heating mode, and the IDU is running in fan mode (note: the wired controller can be used to set whether the heating mode conflicts with the fan mode). ■ The ODU is running in cooling mode, and the IDU is running in heating mode. | |
| Error recovery | Automatic recovery | |
| Possible cause | <ul style="list-style-type: none"> ■ The operation mode of IDU conflicts with that of the ODU. ■ The IDU main control board is damaged. | |
| Troubleshooting | <div style="text-align: center;">  <pre> graph TD A91([A91]) --> D{Reset IDU After operating mode (1), is the error cleared?} D -- Yes --> FC[Fault cleared] D -- No --> RMCB[Replace the main control board of the IDU] </pre> </div> <p>Note:</p> <p>1. For all IDUs in the heat pump system (Except for DC Fresh Air Processing Unit): 1) When the ODU is running in heating mode, the IDU can only operate in heating mode. If you would like to use the fan mode for the IDU, the wired controller needs to be used to change the settings (for more instructions on how to change settings, refer to "Instruction for Use of the wired controller"). 2) When the ODU is running in cooling mode, the IDU can operate in cooling mode or fan mode.</p> | |

2.10 b11, b13 - Error in 1# electronic expansion valve coil, error in 2# electronic expansion valve coil

| Error display | Digital display | Display position |
|-----------------|--|--|
| | | Panel, display box, and wired controller |
| Error impact | The faulty IDU stops. Other IDUs of the same system: operate normally. ODU of the same system: operate normally. | |
| Error trigger | The IDU main control board cannot detect the feedback signal from the electronic expansion valve coil for no less than 4 seconds. | |
| Error recovery | After the unit is powered on again, the main control program detects a feedback signal from the electronic expansion valve. | |
| Possible cause | <ul style="list-style-type: none"> ■ The electronic expansion valve coil plugged into the EEV port in the IDU main control board is loose. ■ The IDU main control board is damaged. ■ The electronic expansion valve coil is faulty. ■ The electronic expansion valve coil is short circuited or disconnected. | |
| Troubleshooting | <div style="text-align: center;"> <pre> graph TD Start([b11/b13 (1)]) --> D1{Is the electronic expansion valve coil plugged into the EXV port in the IDU main control board loose?} D1 -- Yes --> A1[Reconnect the plug tightly] D1 -- No --> D2{Check the electronic expansion valve Is the coil abnormal (2)?} D2 -- Yes --> A2[Replace the electronic expansion valve coil] D2 -- No --> D3{Check the electronic expansion valve Is the coil adapter short circuited or disconnected (3)?} D3 -- Yes --> A3[Replace the adapter] D3 -- No --> A4[Replace the main control board of the IDU] </pre> </div> <p>Note:</p> | |

1. The error code corresponds to the following two situations:
 - a. If there is only one electronic expansion valve port on the main control board of the IDU, when an error occurs in the electronic expansion valve coil connected to the EEV port, the error code is b05.
 - b. If there are two electronic expansion valve ports on the main control board of the IDU named EEV1 and EEV2, when an error occurs in the electronic expansion valve coil connected to port EEV1, the error code is b05; when an error occurs in the electronic expansion valve coil connected to port EEV2, the error code is b07.
2. In Figure 1 below: The numbers 1 to 5 stand for the pins of different colours paired with individual wires which have the same colour as the pin. 5(com) is a pin of the common terminal, and number 6 is a null pin without any wire connected; an XHP coil plug is used to connect to the EEV port of the main control board, and an APM coil plug is used to connect to the A-direction plug of the adapter wire (see Figure 2 below). Table 1 shows the resistance between pin 1-4 and pin 5 (the common terminal) when the electronic expansion valve coil is in a normal state. If the resistance is near zero or significantly deviates from its normal state, the coil is damaged.

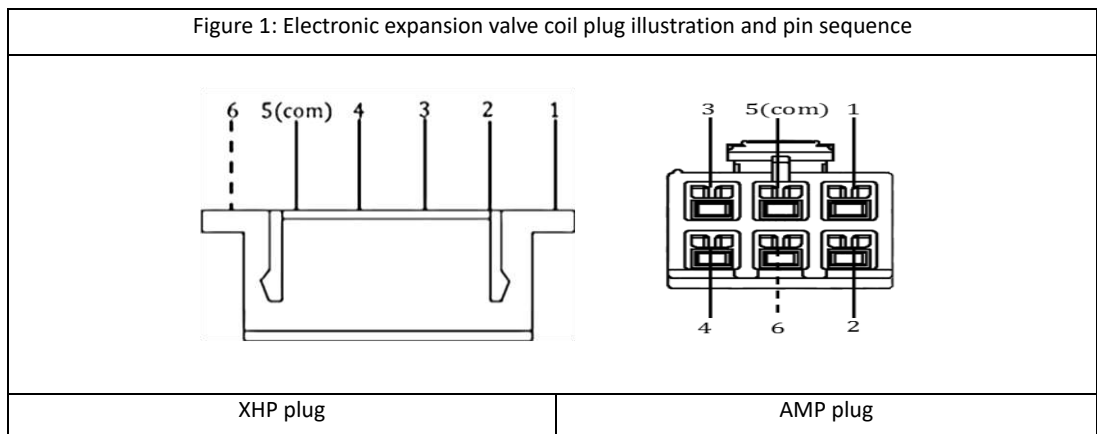
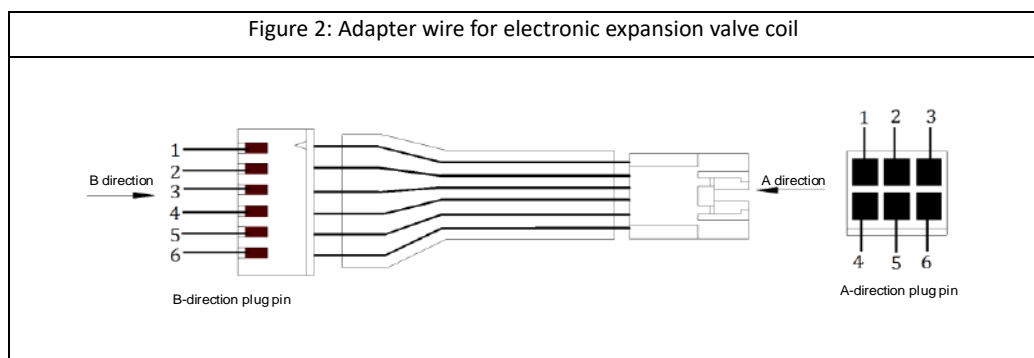

Table 1: Resistance between pins with an electronic expansion valve coil in normal condition

| Pin measured | Resistance in normal status |
|--------------|-----------------------------|
| 1-5 | 40-50Ω |
| 2-5 | 40-50Ω |
| 3-5 | 40-50Ω |
| 4-5 | 40-50Ω |

3. When the distance between the throttle part and the main control board of the IDU in need of connection is too great, you will need an adapter wire for the electronic expansion valve coil. This is shown in Figure 2 below: Use a multimeter to measure the resistance between the pin in the plug at end A of each wire and at end B. A resistance value close to 0 indicates a short circuit has occurred in the wire, and a resistance value close to infinity indicates an open circuit of the wire.



2.11 b12, b14 - Error in 1# electronic expansion valve body, error in 2# electronic expansion valve body

| Error display | Digital display | | Display position | |
|-----------------------|--|--|----------------------------|-----------------------------|
| | | | Panel or display box | Wired controller |
| | | | Spot check interface query | Error code is not displayed |
| Error impact | The faulty IDU and other IDUs of the same system: operate normally. ODU of the same system: operate normally. | | | |
| Error trigger | <ul style="list-style-type: none"> Return air temperature(T1) - Heat exchanger liquid pipe temperature (T2A) > Set value IDU EEV=0, ODU running in cooling mode and compressor speed ≠0 | | | |
| Error recovery | Automatic recovery | | | |
| Possible cause | <ul style="list-style-type: none"> The electronic expansion valve needle is stuck or clogged. The electronic expansion valve coil is damaged and unable to drive the valve body. The IDU main control board is damaged. | | | |

Troubleshooting



```

graph TD
    Start([b12/b14 (1)]) --> D1{Remove the coil and fix it to the valve body again. Is the fault cleared?}
    D1 -- Yes --> R1[Operate normally (loose coil)]
    D1 -- No --> D2{Replace the coil and re-energize. Is the error cleared?}
    D2 -- Yes --> R2[Operate normally (the coil cannot drive the valve body)]
    D2 -- No --> D3{Replace the main control board. Is the fault cleared?}
    D3 -- Yes --> R3[Operate normally (the IDU main control board is damaged and the electronic expansion valve body cannot be driven)]
    D3 -- No --> R4[Replace the electronic expansion valve body (the interior of the body is clogged or the valve needle is stuck)]
    
```

Note:

- The error code corresponds to the following two situations:
 - If there is only one electronic expansion valve port on the main control board of the IDU, when an internal leakage error occurs in the electronic expansion valve body connected to the EEV port, the error code is b12.
 - If there are two electronic expansion valve ports on the main control board of the IDU named EEV1 and EEV2, when there is a leak inside the electronic expansion valve body connected to port EEV1, the error code is b12; when there is a leak inside the electronic expansion valve body connected to port EEV2, the error code is b14.

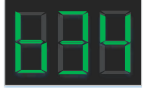
2.12 b34, b35 - Stall protection for 1# water pump, stall protection on 2# water pump

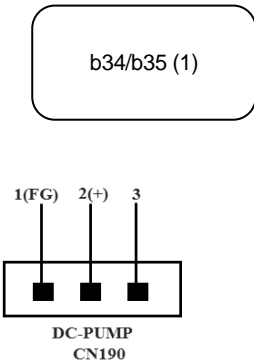
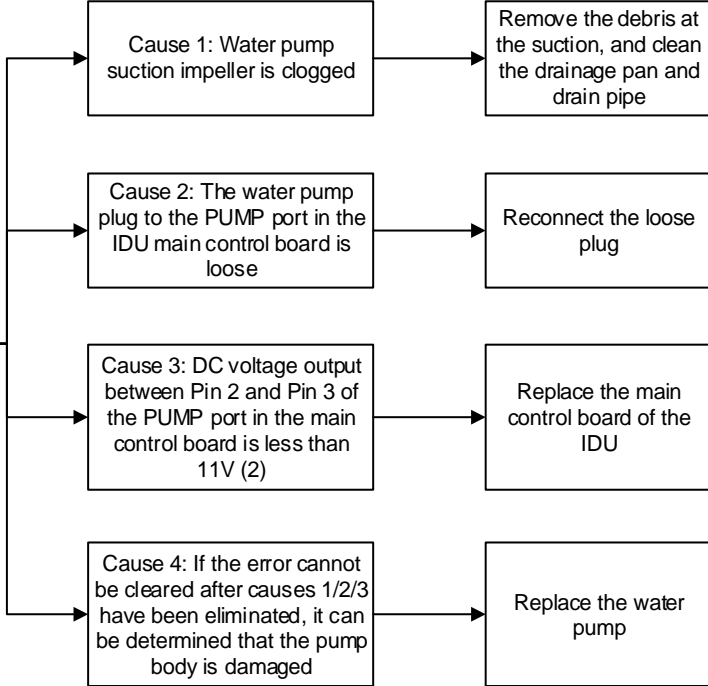
| Error display | Digital display | Display position |
|-----------------|--|---|
| |  |  |
| Error impact | The faulty IDU stops. Other IDUs of the same system: operate normally. ODU of the same system: operate normally. | |
| Error trigger | The main control board of the IDU detects the pump rotation speed ≤ 100 rpm for 10 seconds | |
| Error recovery | Automatic recovery | |
| Possible cause | <ul style="list-style-type: none"> ■ The water pump suction impeller is clogged. ■ The water pump plug to the PUMP port in the IDU main control board is loose. ■ The pump body is damaged (due to motor damage, control drive circuit damage, etc.). ■ The IDU main control board is damaged. | |
| Troubleshooting | <div style="display: flex; align-items: center;"> <div style="margin-right: 20px;">  </div> <div>  </div> </div> <p>Note:</p> <ol style="list-style-type: none"> 1. The error code corresponds to the following two situations: <ol style="list-style-type: none"> 1) If there is only one PUMP port on the main control board of the IDU, when a stall error occurs in the water pump connected to the PUMP port, the error code is b34. 2) If there are two PUMP ports on the main control board of the IDU named PUMP1 and PUMP2, when a stall error occurs in the water pump connected to PUMP1 port, the error code is b34; when a stall error occurs in the water pump connected to PUMP2 port, the error code is b35. 2. Figure 1 above shows the pins of the PUMP port. The output voltage between pin 2 and pin 3 can be measured with a multimeter in DC voltage gear. If the output voltage is less than 11 V, the water pump cannot be driven. | |

2.13 b36 - Water level switch alarm error

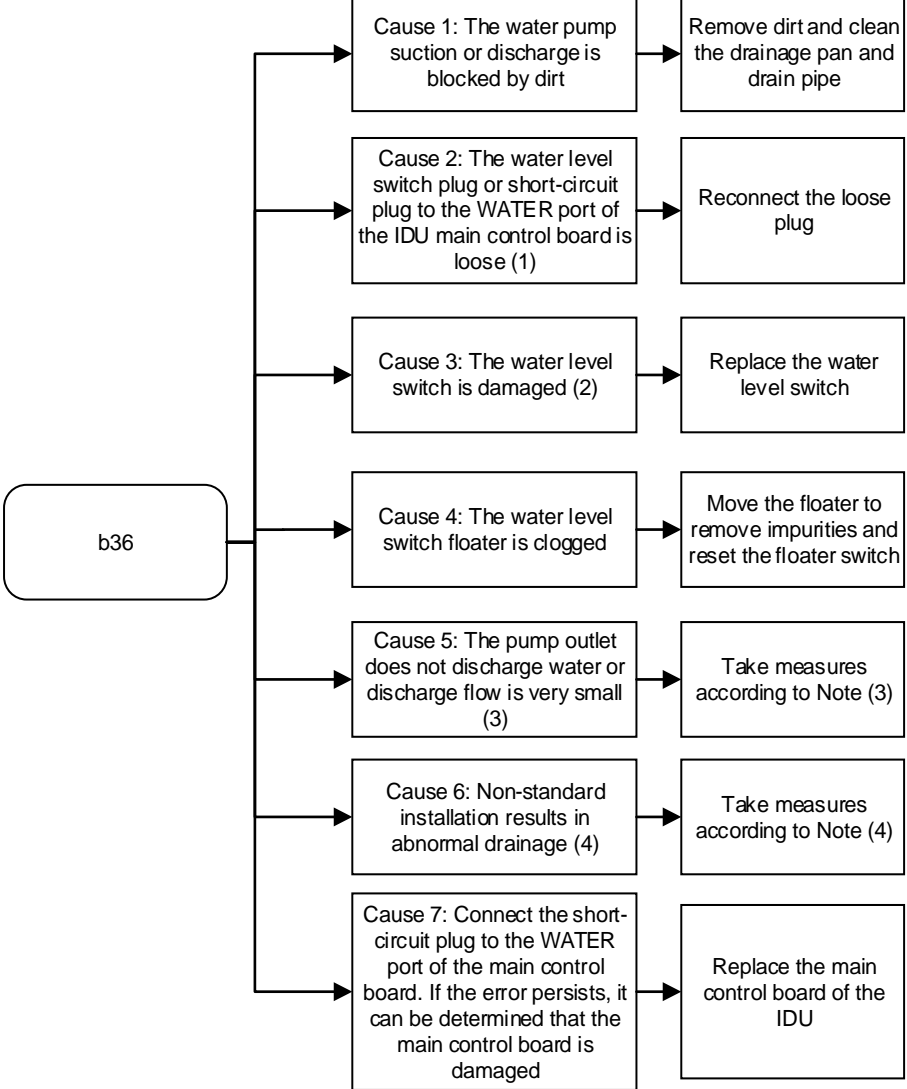
| Error display | Digital display | Display position |
|-----------------|---|--|
| |  | Panel, display box, and wired controller |
| Error impact | The faulty IDU stops. Other IDUs of the same system: operate normally. ODU of the same system: operate normally. | |
| Error trigger | The water level switch alarm is triggered when the floater of the water level switch rises to the warning water level and lasts for 5 min. | |
| Error recovery | Automatic recovery | |
| Possible cause | <ul style="list-style-type: none"> ■ The drain pump/water level switch is damaged. ■ Water level switch float is stuck by a foreign object ■ The water level switch plug or short-circuit plug to the WATER port of the IDU main control board is loose. ■ Non-standard installation results in abnormal drainage: The drain pipe is blocked; the improperly sloped drain pipe causes the condensate water to flow backwards; and the lift of the drain pipe exceeds the allowable value. ■ The IDU main control board is damaged. | |
| Troubleshooting | <div style="text-align: center; margin-bottom: 20px;">  <pre> graph LR b36[b36] --> C1[Cause 1: The water pump suction or discharge is blocked by dirt] b36 --> C2[Cause 2: The water level switch plug or short-circuit plug to the WATER port of the IDU main control board is loose (1)] b36 --> C3[Cause 3: The water level switch is damaged (2)] b36 --> C4[Cause 4: The water level switch floater is clogged] b36 --> C5[Cause 5: The pump outlet does not discharge water or discharge flow is very small (3)] b36 --> C6[Cause 6: Non-standard installation results in abnormal drainage (4)] b36 --> C7[Cause 7: Connect the short-circuit plug to the WATER port of the main control board. If the error persists, it can be determined that the main control board is damaged] C1 --> A1[Remove dirt and clean the drainage pan and drain pipe] C2 --> A2[Reconnect the loose plug] C3 --> A3[Replace the water level switch] C4 --> A4[Move the floater to remove impurities and reset the floater switch] C5 --> A5[Take measures according to Note (3)] C6 --> A6[Take measures according to Note (4)] C7 --> A7[Replace the main control board of the IDU] </pre> </div> <p>Note:</p> <p>1. The plug attached to the WATER port of the main control board corresponds to the following two cases:</p> | |

- a. The factory default of IDUs without a water level switch uses a short-circuit plug to seal the WATER port.
 - b. IDUs with a water level switch use a water level switch plug to seal the WATER port.
2. Use a multimeter to measure the resistance between the pins corresponding to the two wires of the water level switch plug. 1) After the floater of the water level switch is moved upwards to the highest position, the water level switch is in a short-circuited state, and the resistance value is infinite. 2) After the floater of the water level switch is moved downwards to the lowest position, the water level switch is closed, and the resistance value is less than 1 Ω. If the detected resistance value does not meet the above values, the water level switch is damaged.
3. Possible causes and solutions for the situation where the pump outlet does not discharge water or the discharge flow is very small: 1) The water pump plug to the PUMP port in the IDU main control board is loose. Reconnect it firmly. 2) The drain pump suction impeller is clogged. Remove the debris causing the clog to make the pump continue running. 3) If the error cannot be cleared after implementing solutions for causes 1) and 2), the drain pump body is damaged. Replace the drain pump.
4. Possible causes and solutions for abnormal drainage due to non-standard installation: 1) If the drain pipe is blocked, remove the debris and clean the drainage pan and the drain pipe of the IDU. 2) If the drain pipe is improperly installed, which causes the condensate water to flow backward, tilt the IDU to the drainage side by a certain gradient (inclination ≥ 1%). The centralized drain pipe must be lower than the drainage outlet of the unit. Air outlets must be placed at the highest horizontal pipeline (see Installation and Operation Manual of IDUs). 3) If the lift of the drain pipe exceeds the allowable value, reduce the vertical height of the drain pipe or replace the drain pump with the one which has a higher lift.

2.14 C11 - Duplicate IDU address code

| Error display | Digital display | Display position | |
|------------------------|--|---|--|
| | | Panel or display box | Wired controller |
| | | Error code and address code are displayed alternately (2) | Error code and address code flash simultaneously |
| Error impact | Faulty IDU: The fan continues running, and the EEV is closed. Other IDUs of the same system: The fan continues running, the EEV is closed, and error code "A51" is displayed (V6 platform IDU displays the code "Ed"). Meaning of the code: ODU fault ODU of the same system: <ul style="list-style-type: none"> ■ Stop. ■ Error code "C26" is displayed (V6 platform ODU displays the code "H7"). Meaning of the code: IDU qty decrease fault | | |
| Error trigger | Repeated address codes for IDU | | |
| Error recovery | Automatic recovery | | |
| Possible cause | <ul style="list-style-type: none"> ■ Duplicate IDU address code (▲) ■ The IDU main control board is damaged. | | |
| Troubleshooting | <div style="text-align: center;"> <pre> graph TD Start([C11]) --> Decision{Locate the IDU that reports repeated addresses. Is the address repeated?} Decision -- Yes --> Action1[Reset the address (1)] Decision -- No --> Action2[Replace the main control board of the IDU (the communication circuit of the main control board is damaged)] </pre> </div> <p>(▲): The common reasons for address code duplication are as follows:</p> <ol style="list-style-type: none"> 1. After replacing the main control board, the address was not reset, resulting in address duplication. The address can be manually set using the controller or the indoor unit address can be cleared at the outdoor unit and then automatically addressed again. 2. In systems where the nominal capacity of an indoor unit is greater than or equal to 20KW, the indoor unit usually occupies more than two addresses (one real address + several virtual addresses, see Note 1 below), which may cause the addresses of other indoor units in the system to duplicate with the virtual addresses of the large indoor unit. In this case, the indoor unit address can be cleared at the outdoor unit and then automatically addressed again, or the controller can be used to manually set the address to avoid duplicate codes when the duplicate address code is known. <p>Note:</p> | | |

1. The following table shows the number of addresses and address codes for any indoor unit (AHU kit/direct expansion unit not applicable) with different capacities (HP)

| Nominal capacity (kW) | capacity (HP) | Number of IDUs (N) | Number of addresses (N) | Address code | Address code to be queried at the centralized controller or wired controller (★) |
|-----------------------|---------------|--------------------|-------------------------|---|--|
| kW<20 | HP<7 | 1 | 1 | Address code can be any integer from 0 to 63, denoted by X | X |
| 20≤kW<40 | 7≤HP<14 | 1 | 2 | The address code can be any integer from 0 to 62, denoted by X, and the virtual address following it is X+1 | X |
| 40≤kW<78.5 | 14≤HP<28 | 1 | 4 | The address code can be any integer from 0 to 60, denoted by X, and the virtual addresses following it are: X+1, X+2, X+3 | X |
| 78.5≤kW<101 | 28≤HP<36 | 1 | 5 | The address code can be any integer from 0 to 59, denoted by X, and the virtual addresses following it are: X+1, X+2, X+3, X+4 | X |
| 101≤kW<112 | 36≤HP<40 | 1 | 6 | The address code can be any integer from 0 to 58, denoted by X, and the virtual addresses following it are: X+1, X+2, X+3, X+4, X+5 | X |
| kW>112 | HP>40 | 1 | 8 | The address code can be any integer from 0 to 56, denoted by X, and the virtual addresses following it are: X+1, X+2, X+3, X+4, X+5, X+6, X+7 | X |

★Example: If one IDU is 5 HP and the address code is set to 1, then the query address at the centralized controller side or wired controller side is 1. If one IDU is 20 HP and the address code is set to 5, then this IDU has four address codes, which are 5, 6, 7, and 8, but the query address at the centralized controller side or wired controller side is 5.

2. Repeated display of address codes and confirmation of repeated address codes

| | Error code | Display box/panel | Wired controller |
|---|------------|---|-------------------------------|
| IDU with repeated address codes (number of addresses N = 1) | C11 | Error code "C11" and address code are displayed alternately every 1s (★1) | Error code "C11" is displayed |
| IDU with repeated address codes (number of addresses N>1) | C11 | If the number of repeated address codes is 1, then the error code "C11" is displayed alternately with the minimum address code every 1s. If the number of repeated address codes is >1, then the error code "C11" is displayed alternately with the minimum address code every 1s; (★2) | Error code "C11" is displayed |

★ Example 1: If IDU 1 is 5 HP and the address code is set to 1, and IDU 2 is 5 HP and the address code is set to 1 too, then the display box or panel of IDU 1 and IDU 2 will alternately display the code C11 and the address code 1.

★Example 2: If IDU 1 is 20 HP and the address code is set to 1 (the addresses actually occupied are 1, 2, 3, and 4), IDU 2 is 5 HP and the address code is set to 2, IDU 3 is 5 HP and the address code is set to 3, then the display box or panel of IDU 1 will alternately display the code C11 and the address code 2 (If there are multiple repeated addresses, then the minimum address code is displayed); the display box or panel of IDU 2 will alternately display the code C11 and the address code 2; and the display box or panel of IDU 3 will alternately display the code C11 and the address code 3.

2.15 C21 - Abnormal communication between IDU and ODU

| Error display | Digital display | Display position |
|-----------------|---|--|
| Error display | | Panel, display box, and wired controller |
| Error impact | Faulty IDU: The fan continues running, and the EEV is closed. Other IDUs of the same system: The fan continues running, the EEV is closed, and error code "A51" is displayed (V6 platform IDU displays the code "Ed"). Meaning of the code: ODU fault | |
| Error impact | ODU of the same system: <ul style="list-style-type: none"> ■ stops. ■ Error code "C26" is displayed (V6 platform ODU displays the code "H7"). Meaning of the code: IDU qty decrease fault | |
| Error trigger | If the IDU has not received any communication signal from ODU for 2 min | |
| Error recovery | Automatic recovery | |
| Possible cause | See the Troubleshooting section. | |
| Troubleshooting | <p>■ If the indoor and outdoor units communicate via RS-485(PQE/PQ):</p> <div style="text-align: center;"> </div> | |
| | <p>Note 1: If you measure the resistance between ports P, Q, and E of the IDU main control board, normally the resistance between P and Q is 120 Ω, the resistance between P and E is infinite, and the resistance between Q and E is infinite.</p> | |

Troubleshooting

■ If the indoor and outdoor units communicate via HyperLink (M1M2):

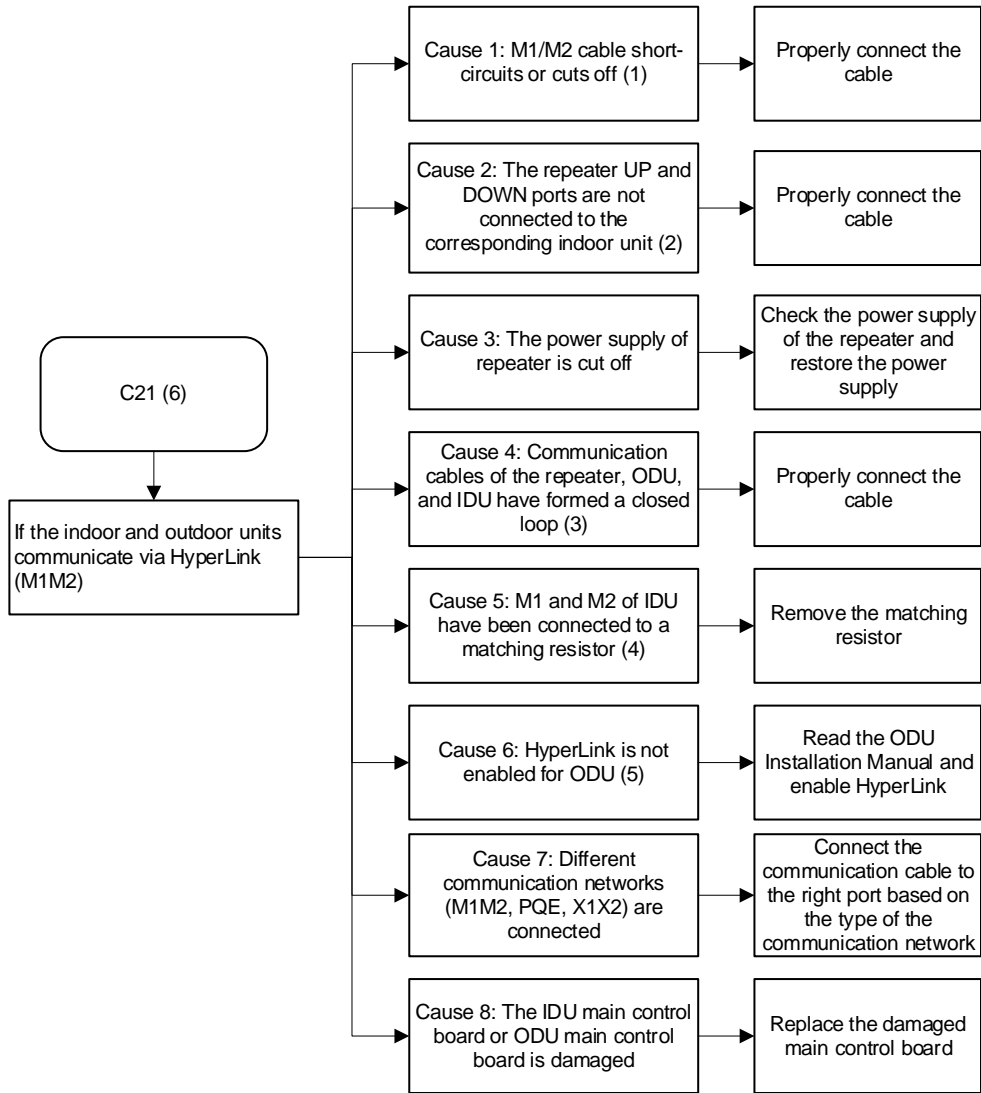

Note:

1. If you measure the resistance between terminal blocks M1 and M2 of the IDU main control board, normally this resistance is greater than 1 MΩ.
2. Figure 1 shows the schematic diagram of HyperLink communication line connection. The connection of repeater wires must comply with the following requirements. Otherwise, an IDU communication fault may occur.

Figure 1 Schematic diagram of HyperLink communication cable connection

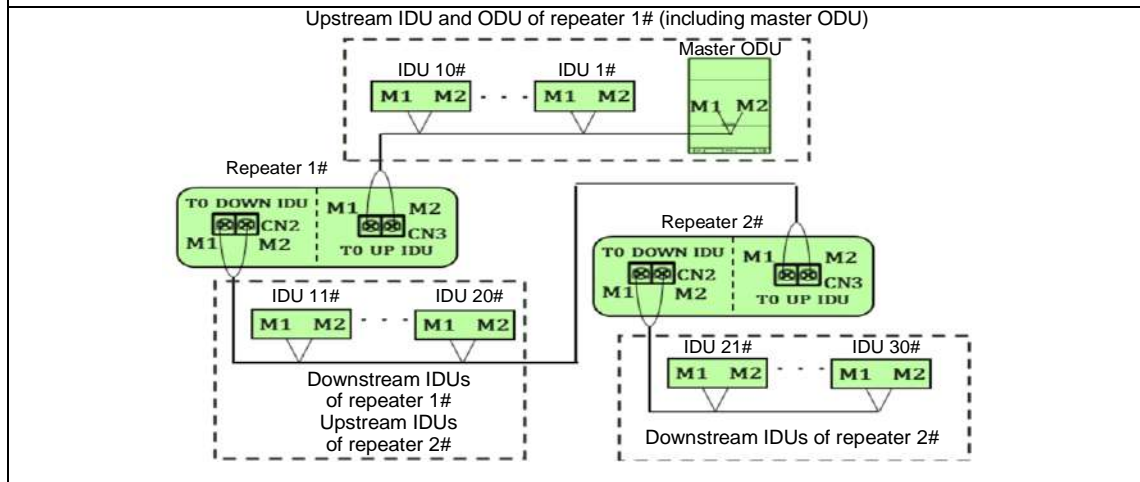

- 1) The UP communication port of 1# repeater is connected to the communication port of 10# IDU, and the DOWN communication port of 1# repeater is connected to the communication port of 11# IDU.
- 2) The UP communication port of 2# repeater is connected to the communication port of 20# IDU, and the DOWN communication port of 2# repeater is connected to the communication port of 21# IDU.
- 3) For each repeater added, 10 IDUs and 200 m communication distance can be added. A refrigerant system allows the addition of a maximum of 2 repeaters and can connect to up to 30 IDUs. If more than 30 IDUs are connected, please allocate separate refrigerant systems.
3. If communication cables connecting the communication ports of the repeater, IDU and ODU form a closed loop, it will cause a communication fault.
4. RS-485 communication cables must be connected hand in hand. If communication is unstable, a matching resistor needs to be added to the last IDU on the PQ (in the accessory bag of the ODU). However, a matching resistor should not be added between M1 and M2. Otherwise, a communication fault may occur.
5. To select the communication mode HyperLink (M1M2), users must go to the ODU menu item to change the mode (For the setting method, refer to the ODU Installation Manual). Otherwise, communication faults may occur.
6. The V8 platform ODU typically uses the V8 communication protocol. If there are any IDUs that use a non-V8 platform, users must go to the ODU menu item to change the communication protocol (Please refer to the ODU Installation Manual for setup instructions). Otherwise, these IDUs will display communication fault codes (For the code number, please refer to the IDU wiring nameplate).

2.16 C41 - Abnormal communication between IDU main control board and fan drive board

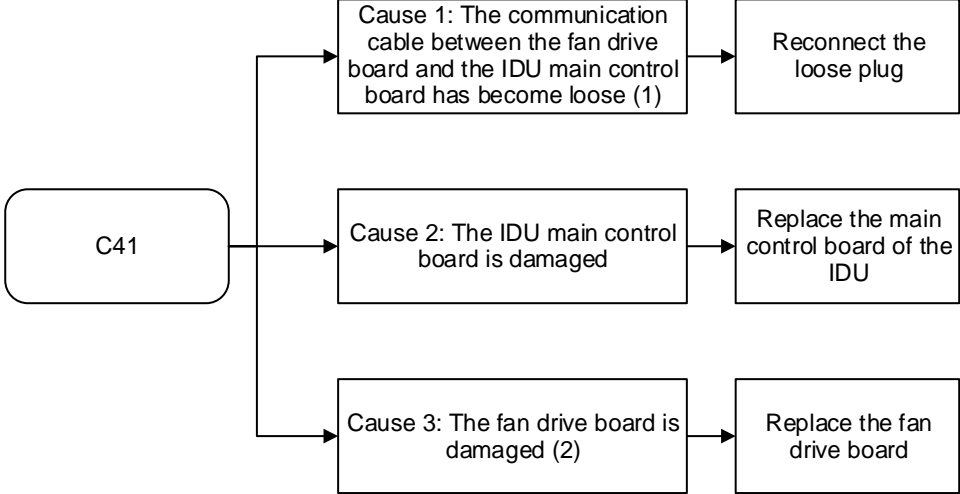
| Error display | Digital display | Display position |
|-----------------|---|--|
| |  | Panel, display box, and wired controller |
| Error impact | The faulty IDU stops. Other IDUs of the same system: operate normally. ODU of the same system: operate normally. | |
| Error trigger | If the main control board of an IDU has lost communication with the fan drive board for 2 min (3) | |
| Error recovery | Automatic recovery | |
| Possible cause | <ul style="list-style-type: none"> ■ The fan drive board is damaged. ■ The IDU main control board is damaged. ■ The communication cable between the fan drive board and the IDU main control board has become loose. | |
| Troubleshooting | <div style="text-align: center;">  <pre> graph LR C41([C41]) --> C1[Cause 1: The communication cable between the fan drive board and the IDU main control board has become loose (1)] C41 --> C2[Cause 2: The IDU main control board is damaged] C41 --> C3[Cause 3: The fan drive board is damaged (2)] C1 --> R1[Reconnect the loose plug] C2 --> R2[Replace the main control board of the IDU] C3 --> R3[Replace the fan drive board] </pre> </div> <p>Note:</p> <ol style="list-style-type: none"> 1. Communication cables are only provided for units whose fan drive board is independent of the IDU main control board. 2. For units whose fan drive board is welded onto the main control board, if either the fan drive board or main control board becomes faulty, the whole control board has to be replaced. | |

2.17 C51: communication exception between the IDU and wired controller

Note: The error code C51 can be triggered either at the IDU side or the wired controller side.

| | LED display | Display position |
|-----------------------|--|---|
| Fault Display |  | <p>If a powered-on IDU does not receive any message from the wired controller: 1) Wired controller: "C51" is displayed; 2) Panel or display box: The LED display and the error code bit on the inspection interface are displayed normally.</p> <p>If a powered-on IDU receives any message from the wired controller: 1) Wired controller: "C51" is displayed; 2) Panel or display box: The LED display is normal, and "C51" is displayed in the error code bit on the inspection interface.</p> |
| Fault Impact | <ul style="list-style-type: none"> ■ Triggered at the IDU side: The faulty IDU and other IDUs of the same system operate normally. ■ Triggered at the wired controller side: The wired controller is unavailable. <p>ODU of the same system operates normally.</p> | |
| Fault Trigger | <ul style="list-style-type: none"> ■ Triggered at the IDU side: The IDU main control board experiences a two-minute communication interruption with the wired controller. ■ Triggered at the wired controller side: The wired controller has not received any reply from the IDU main control board for one continuous minute. | |
| Fault Recovery | Automatic recovery | |
| Possible Cause | <ul style="list-style-type: none"> ■ The wired controller is damaged. ■ The IDU main control board is damaged. ■ Communication wires are loose or the communication port is faulty. ■ Communication wires have short-circuited or been cut off. ■ The communication wire does not meet anti-interference requirements or is affected by strong-current interference. ■ IDU has no address. | |

Troubleshooting

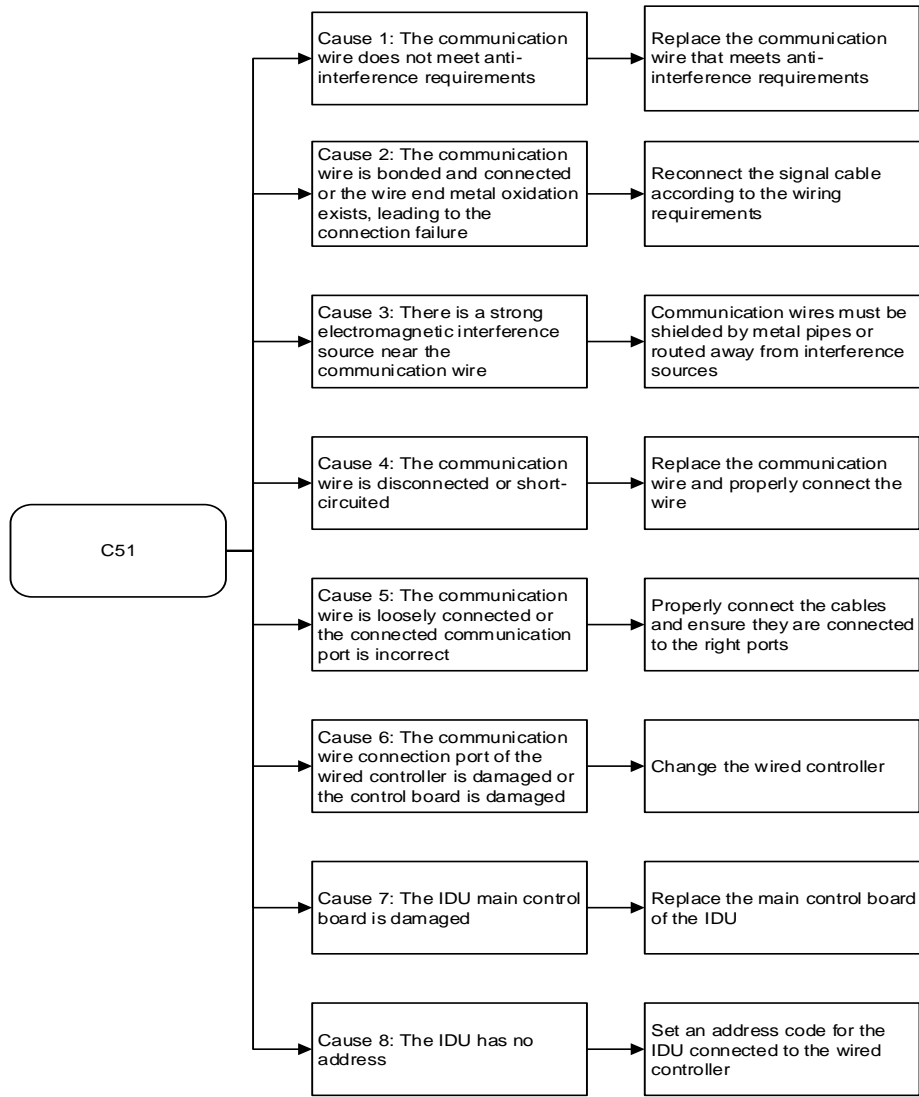

2.18 C61 - Abnormal communication between the IDU main control board and display control board

Note: The error code C61 can be triggered either at the IDU side or at the panel or display box side.

| | Digital display | Display position |
|-----------------------|--|---|
| Error display | | After power on, normal communication was not established between the indoor unit and the wired controller: 1) The wired controller does not display fault code; 2) The panel or display box displays "C61". |
| | | After power on, normal communication was established between the indoor unit and the wired controller: 1) The wired controller displays "C61"; 2) The panel or display box displays "C61". |
| Error impact | The faulty IDU and other IDUs of the same system: operate normally. | |
| | ODU of the same system: operate normally. | |
| Error trigger | <ul style="list-style-type: none"> ■ Triggered at the IDU side: If the main control board of the IDU has been connected to the display board but has not communicated with the display board for 2 min; ■ Triggered at panel or display box side: If the display board has not received any reply from the main control board of an IDU for 1 min | |
| Error recovery | Automatic recovery | |
| Possible cause | <ul style="list-style-type: none"> ■ Unplug the display box or panel communication wire from the main control board of powered indoor unit. ■ Use a wrong port to connect display control board and IDU main control board. ■ The communication wire between the display control board and the IDU main control board has become loose. ■ Short circuit or open circuit in communication wire ■ The display box or panel does not match the indoor unit model. ■ The display control board is damaged. ■ The IDU main control board is damaged. | |

Troubleshooting

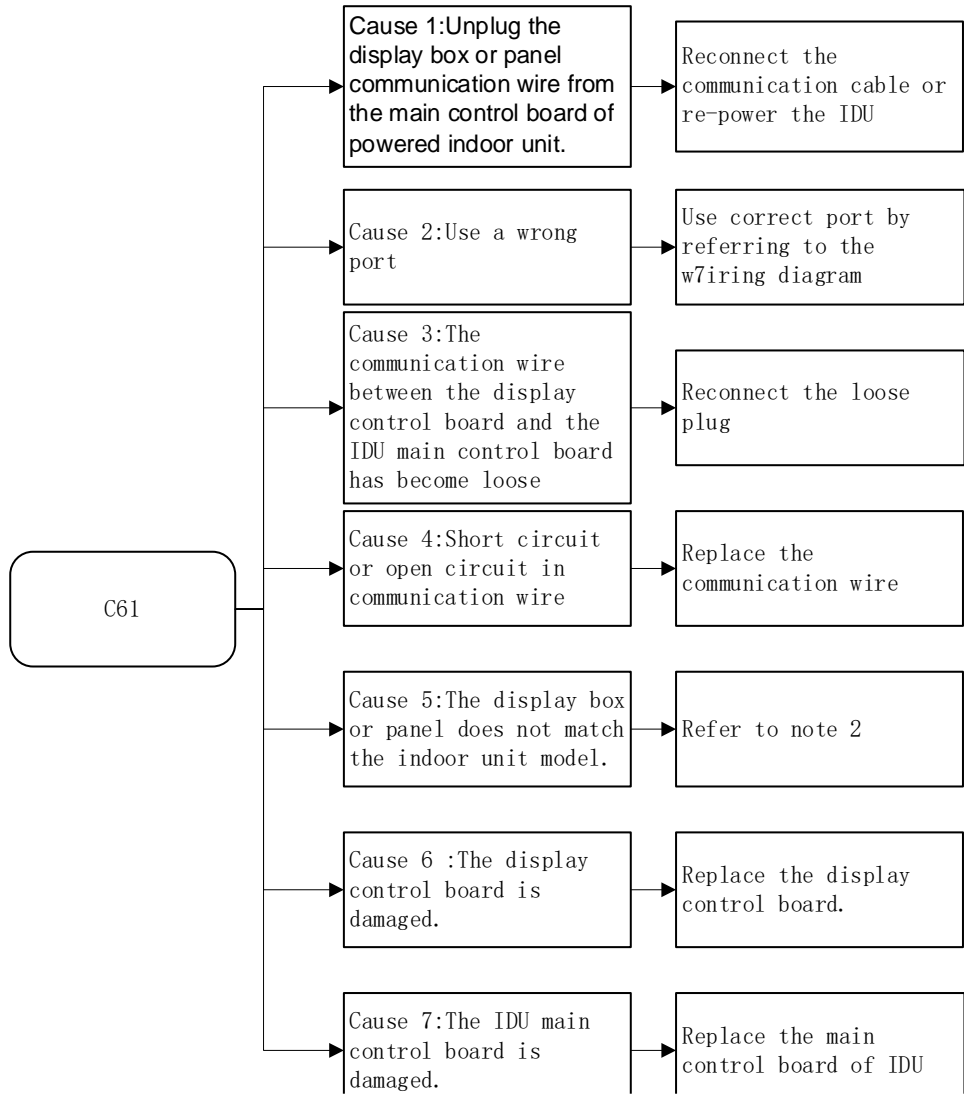

Note:

1. The control boards of display box and panel are uniformly named as display control board.
2. Check whether the model of display box and panel is correct and the type of the indoor unit main control board is set correctly

2.19 C73 - Abnormal communication between the linked humidifying IDU and master IDU

| | | | |
|-----------------|--|-------------------------------|-----------------------------|
| Error display | Digital display | Display position (master IDU) | |
| | | Panel or display box | Wired controller |
| | | Spot check interface query | Error code is not displayed |
| Error impact | Master IDU: operates normally. Humidifying IDUs: stop. Other IDUs of the same system: operate normally. ODU of the same system: operate normally. | | |
| Error trigger | If the main control board of the master IDU has lost communication with the main control board of the humidifying IDU for 2 min | | |
| Error recovery | Automatic recovery | | |
| Possible cause | <ul style="list-style-type: none"> ■ The main control board of the humidifying IDU is damaged. ■ The master IDU's main control board is damaged. ■ Communication cables are loose or the communication port is faulty. ■ Communication cables have short-circuited or been cut off. | | |
| Troubleshooting | <div style="display: flex; align-items: center;"> <div style="border: 1px solid black; border-radius: 15px; padding: 10px; margin-right: 20px;">C73</div> <div style="flex-grow: 1;"> <pre> graph LR C73[C73] --> C1[Cause 1: The communication cable between the main control board of the humidifying IDU and the main control board of master IDU is disconnected or short circuited] C73 --> C2[Cause 2: The communication cable between the main control board of the humidifying IDU and the main control board of the master IDU has become loose or is connected to a wrong port] C73 --> C3[Cause 3: The main control board of the master IDU is damaged] C73 --> C4[Cause 4: The main control board of the humidifying IDU is damaged] C1 --> R1[Replace the communication cable and properly connect the cable] C2 --> R2[Properly connect the cables and ensure they are connected to the right ports] C3 --> R3[Replace the main control board of the master IDU] C4 --> R4[Replace the main control board of the humidifying IDU] </pre> </div> </div> <p>Note:</p> <ol style="list-style-type: none"> The error code can be queried after the humidifying IDU is connected to the wired controller or the display box. | | |

2.20 C74 - Abnormal communication between the linked FAPU and master IDU (series setting)

Note:

- 1) The type of FAPU may be HRV, VRF fresh air IDU and so on.
- 2) Series setting: The air supply side of the linked FAPU is directly connected to the air return side of the master IDU through an air duct. A wired controller is used to set this installation method as a series connection.

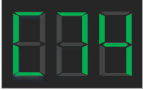
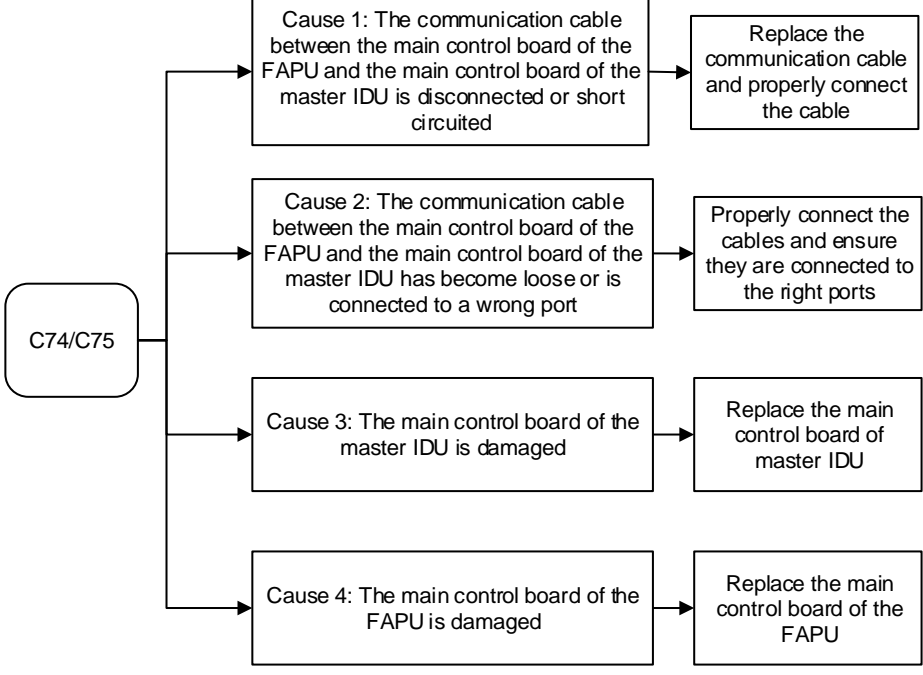
| Error display | Digital display | Display position (master IDU) |
|------------------------|---|--|
| |  | Panel, display box, and wired controller |
| Error impact | The master IDU and the linked FAPU: stop. Other IDUs of the same system: operate normally. | |
| | ODU of the same system: operate normally. | |
| Error trigger | If the main control board of the master IDU has lost communication with the main control board of the FAPU for 2 min | |
| Error recovery | Automatic recovery | |
| Possible cause | <ul style="list-style-type: none"> ■ The main control board of the FAPU is damaged. ■ The master IDU's main control board is damaged. ■ Communication cables are loose or the communication port is faulty. ■ Communication cables have short-circuited or been cut off. | |
| Troubleshooting | <div style="display: flex; align-items: center;"> <div style="border: 1px solid black; border-radius: 15px; padding: 5px; margin-right: 20px;">C74/C75</div> <div style="flex-grow: 1;">  <pre> graph LR A(C74/C75) --> B1[Cause 1: The communication cable between the main control board of the FAPU and the main control board of the master IDU is disconnected or short circuited] A --> B2[Cause 2: The communication cable between the main control board of the FAPU and the main control board of the master IDU has become loose or is connected to a wrong port] A --> B3[Cause 3: The main control board of the master IDU is damaged] A --> B4[Cause 4: The main control board of the FAPU is damaged] B1 --> C1[Replace the communication cable and properly connect the cable] B2 --> C2[Properly connect the cables and ensure they are connected to the right ports] B3 --> C3[Replace the main control board of master IDU] B4 --> C4[Replace the main control board of the FAPU] </pre> </div> </div> <p>Note:</p> <ol style="list-style-type: none"> 1. The error code can be queried after the FAPU is connected to the wired controller or the display box. | |

2.21 C75 - Communication fault between linked FAPU and master IDU (non-series setting)

Note:

- 1) The type of FAPU may be HRV, VRF fresh air IDU and so on.
- 2) Series setting: The linked FAPU and the master IDU are connected to the air supply duct and air return duct respectively and separately. A wired controller is used to set this installation method as a non-series connection.

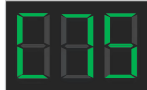
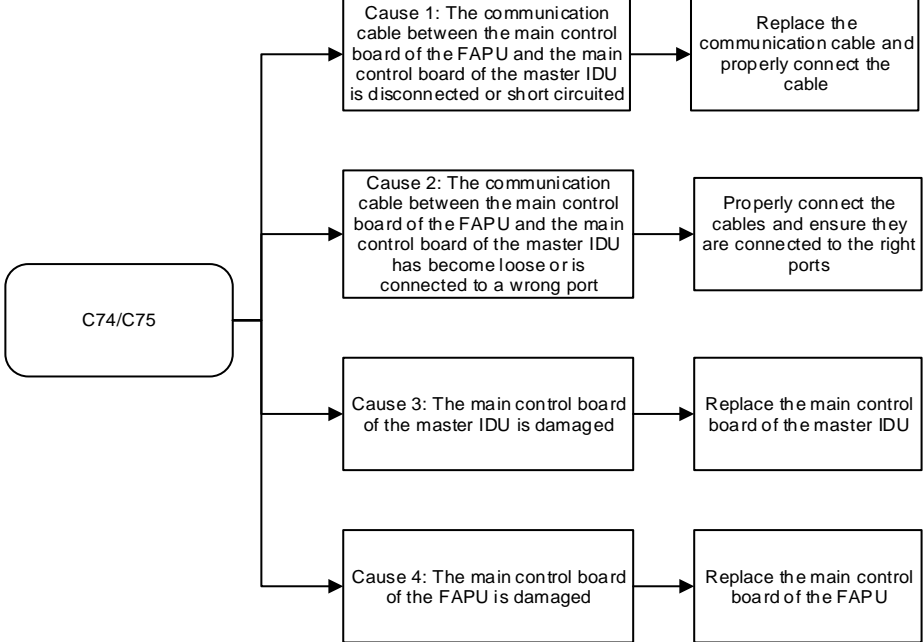
| Error display | Digital display | | Display position (master IDU) | |
|------------------------|--|----------------------------|-------------------------------|--|
| |  | Panel or display box | Wired controller | |
| | | Spot check interface query | Error code is not displayed | |
| Error impact | Master IDU: operates normally. FAPU: stops. Other IDUs of the same system: operate normally. | | | |
| | ODU of the same system: operate normally. | | | |
| Error trigger | If the main control board of the master IDU has lost communication with the main control board of the FAPU for 2 min | | | |
| Error recovery | Automatic recovery | | | |
| Possible cause | <ul style="list-style-type: none"> ■ The main control board of the FAPU is damaged. ■ The master IDU's main control board is damaged. ■ Communication cables are loose or the communication port is faulty. ■ Communication cables have short-circuited or been cut off. | | | |
| Troubleshooting | <div style="display: flex; align-items: center; justify-content: center;"> <div style="border: 1px solid black; border-radius: 15px; padding: 5px; margin-right: 20px;">C74/C75</div>  </div> <p>Note:</p> <ol style="list-style-type: none"> 1. The error code can be queried after the FAPU is connected to the wired controller or the display box. | | | |

2.22 C76 - Abnormal communication between the main wired controller and secondary wired controller

Note: The error code C51 can be triggered either at the IDU side or at the wired controller side.

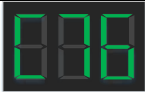
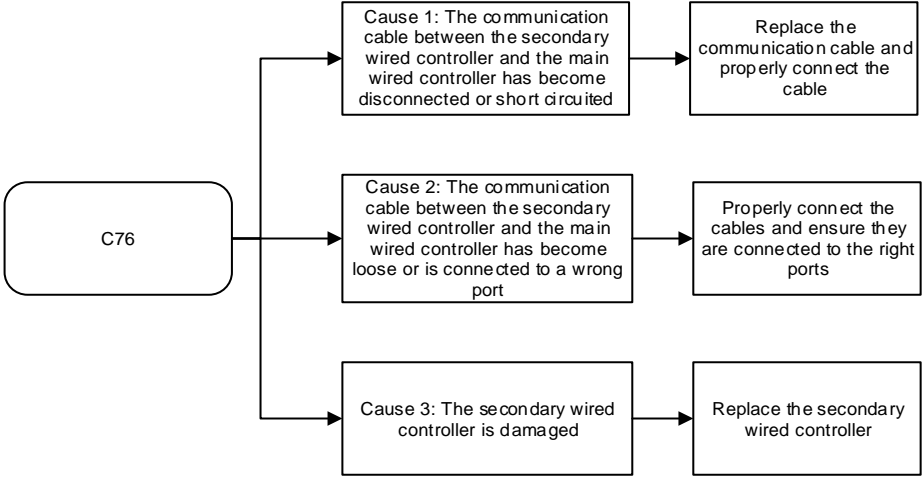
| | Digital display | Display position |
|------------------------|---|--|
| Error display |  | The error code "C76" is displayed only on the secondary wired controller |
| Error impact | The faulty IDU and other IDUs of the same system: operate normally. The wired controller does not work. ODU of the same system: operate normally. | |
| Error trigger | If the secondary wired controller has not received any reply from the main wired controller for 1 min | |
| Error recovery | Automatic recovery | |
| Possible cause | <ul style="list-style-type: none"> ■ The secondary wired controller is damaged. ■ Communication cables are loose or the communication port is faulty. ■ Communication cables have short-circuited or been cut off. | |
| Troubleshooting |  | |

2.23 C77, C78 - Abnormal communication between IDU main control board and 1# Expansion Board, abnormal communication between IDU main control board and 2# Expansion Board

| Error display | Digital display | | Display position |
|----------------|--|--|--|
| | | | Panel, display box, and wired controller |
| Error impact | Faulty IDU: The fan continues running, and the EEV is closed. Other IDUs of the same system: operate normally. | | |
| | ODU of the same system: operate normally. | | |
| Error trigger | If the main control board of an IDU has lost communication with 1# Expansion Board or 2# Expansion Board for 2 min | | |
| Error recovery | Automatic recovery | | |
| Possible cause | See the Troubleshooting section. | | |

Troubleshooting

Note: The main control board of the IDU cannot be directly connected to the Expansion Board. Instead, a Switch module has to be used. See Figure 1 below:

Figure 1 Wiring diagram of Expansion Board, Switch module, and IDU main control board

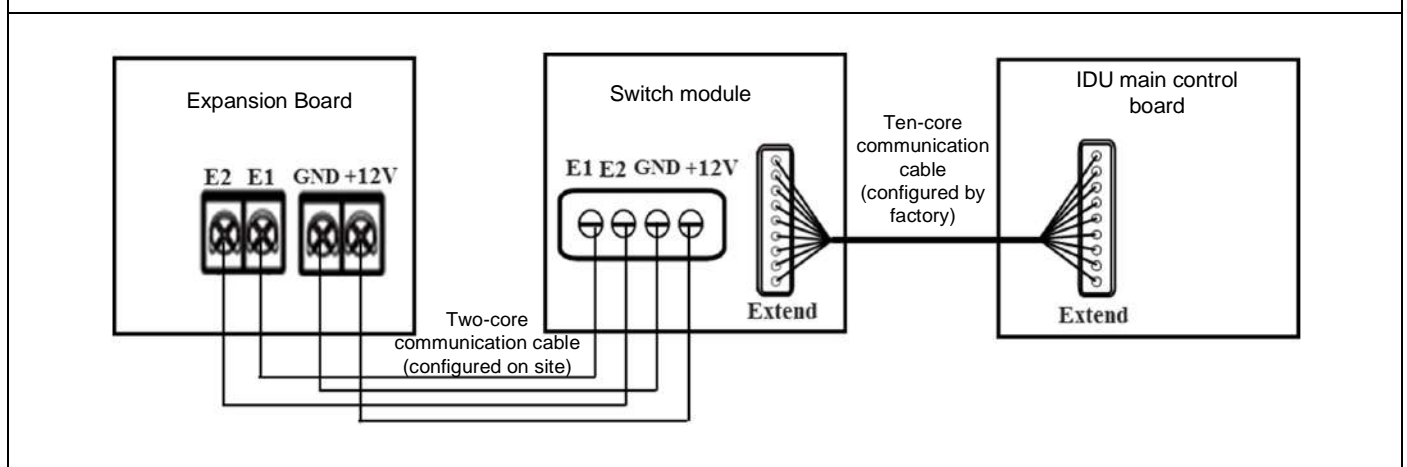

2.24 C79 - Abnormal communication between the IDU main control board and Switch module

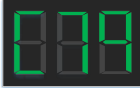
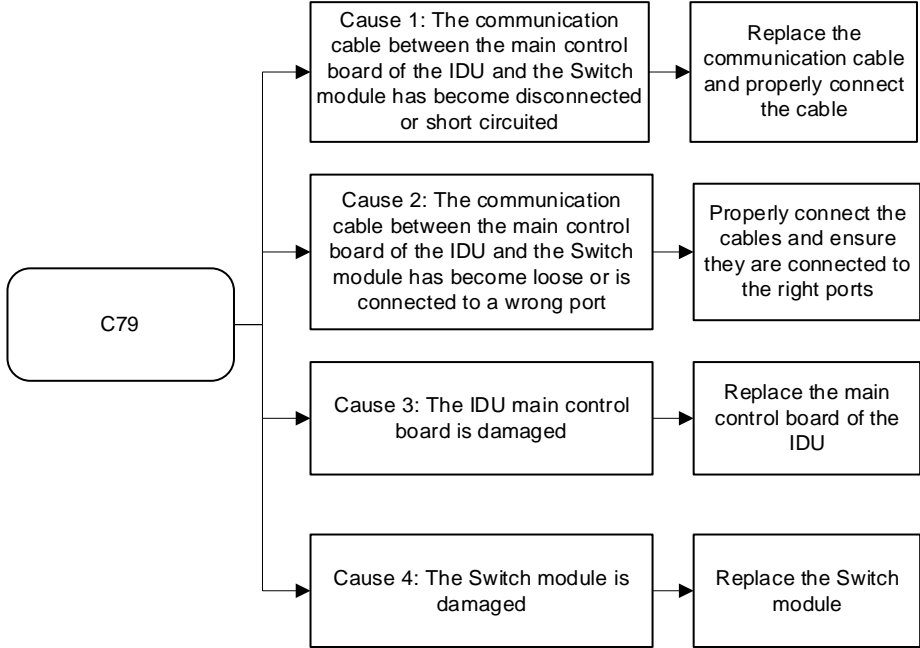
| Error display | Digital display | Display position |
|-----------------|---|--|
| |  | Panel, display box, and wired controller |
| Error impact | Faulty IDU: The fan continues running, and the EEV is closed. Other IDUs of the same system: operate normally. ODU of the same system: operate normally. | |
| Error trigger | If the main control board of an IDU has lost communication with the Switch module for 2 min | |
| Error recovery | Automatic recovery | |
| Possible cause | See the Troubleshooting section. | |
| Troubleshooting |  <pre> graph LR C79(C79) --> C1[Cause 1: The communication cable between the main control board of the IDU and the Switch module has become disconnected or short circuited] C79 --> C2[Cause 2: The communication cable between the main control board of the IDU and the Switch module has become loose or is connected to a wrong port] C79 --> C3[Cause 3: The IDU main control board is damaged] C79 --> C4[Cause 4: The Switch module is damaged] C1 --> S1[Replace the communication cable and properly connect the cable] C2 --> S2[Properly connect the cables and ensure they are connected to the right ports] C3 --> S3[Replace the main control board of the IDU] C4 --> S4[Replace the Switch module] </pre> | |

2.25 C81—The indoor unit is in a power-off state

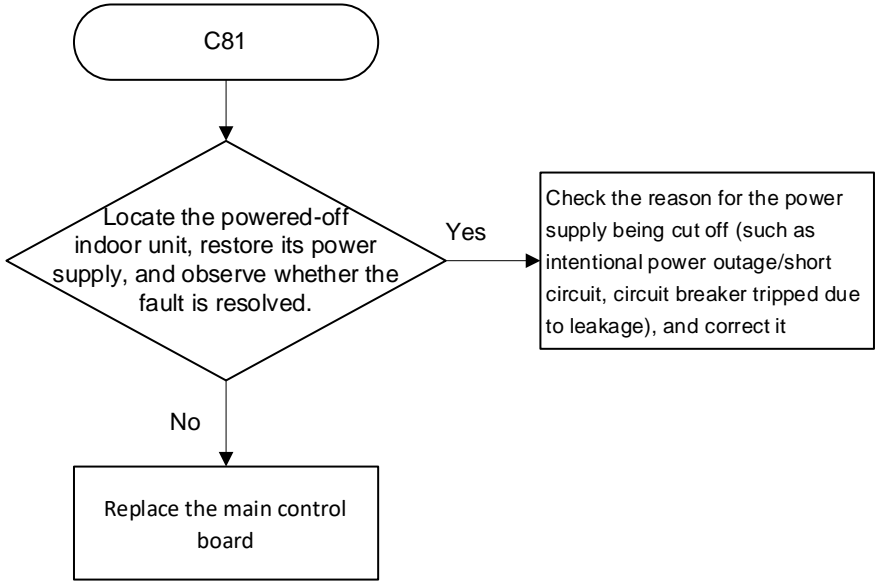
| | Digital display | Display position |
|------------------------|--|--|
| Error display |  | Central controller or various types of control terminal software |
| Error impact | <ul style="list-style-type: none"> ■ The faulty indoor unit and the panels, display boxes, and wired controllers connected to it will stop running, and the central controller or various types of control terminal software will display "C81". ■ Other indoor units in the same system are operating normally. The outdoor unit in the same system is operating normally, displaying 'd41'(There are indoor units in the system that are in a powered-off state). HyperLink will closes the electronic expansion valve of the powered-off indoor unit. | |
| Error trigger | The power supply to the indoor unit has been detected as being cut off. | |
| Error recovery | The faulty indoor unit will automatically resume operation once power supply is restored. | |
| Possible cause | <ul style="list-style-type: none"> ■ The power supply to the indoor unit has been cut off. ■ The main control board of the indoor unit is damaged | |
| Troubleshooting | <div style="text-align: center;">  <pre> graph TD Start([C81]) --> Decision{Locate the powered-off indoor unit, restore its power supply, and observe whether the fault is resolved.} Decision -- Yes --> YesBox[Check the reason for the power supply being cut off (such as intentional power outage/short circuit, circuit breaker tripped due to leakage), and correct it] Decision -- No --> NoBox[Replace the main control board] </pre> </div> <p>Note: The C81 fault trigger is only supported when both the indoor and outdoor units belong to the V8 series and the communication line between the indoor and outdoor units is connected to the M1/M2 ports.</p> | |

2.26 d16 - Air inlet temperature of IDU is too low in heating mode

| | | |
|-----------------------|---|--|
| Error display | Digital display | Display position |
| | | Panel, display box, and wired controller |
| Error impact | The faulty IDU stops. Other IDUs of the same system: operate normally. | |
| | ODU of the same system: operate normally. | |
| Error trigger | If the air inlet temperature of the IDU is lower than the set value (See the operating temperature range set out in the IDU Manual) for 5 min in heating mode | |
| Error recovery | Automatic recovery | |
| Possible cause | See the Troubleshooting section. | |

| | | |
|------------------------|--|--|
| Troubleshooting | | |
| | <p>Note:</p> <p>1. The inlet air temperature sensor is commonly found in the fresh air IDUs (The sensor code is defined as T0), and its resistance and temperature characteristics are similar to T1 - return air temperature sensor. Please refer to the Table of Temperature Sensor Resistance Characteristics listed in the Maintenance Manual to learn more about the sensor's features.</p> | |

2.27 d17 - Air inlet temperature of IDU is too high in cooling mode

| | | |
|----------------|--|--|
| Error display | Digital display | Display position |
| | | Panel, display box, and wired controller |
| Error impact | The faulty IDU stops. Other IDUs of the same system: operate normally. | |
| | ODU of the same system: operate normally. | |
| Error trigger | If the air inlet temperature of the IDU is higher than the set value (See the operating temperature range set out in the IDU Manual) for 5 min in cooling mode | |
| Error recovery | Automatic recovery | |
| Possible cause | See the Troubleshooting section. | |

Troubleshooting

```

    graph LR
      d17((d17)) --> C1[Cause 1: Spot check the inlet air temperature and measure the inlet air temperature. If the point check result is the same as the measured result (error ≤ 1°C), it is a normal protection measure for the unit. Otherwise, refer to cause 2/3/4]
      d17 --> C2[Cause 2: Remove the plug of the inlet air temperature sensor from the main control board of the IDU, measure its resistance value, and compare it with the Table of Sensor Resistance - Temperature Characteristics (1). If the temperature that corresponds to the resistance value deviates from the actual inlet air temperature by more than 5°C, the sensor is damaged.]
      d17 --> C3[Cause 3: The sensor body has come into contact with a hot source, such as direct sunlight or hot surface of a heat exchanger, which causes the detected value to be lower than the normal value]
      d17 --> C4[Cause 4: If the error cannot be cleared after causes 1/2/3 have been eliminated, the main control board of the IDU is damaged]
      C1 --> R1[It is a normal protection measure for the IDU. When the inlet air temperature is lower than the set value, the fault will be cleared]
      C2 --> R2[Replace the inlet air temperature sensor]
      C3 --> R3[Eliminate the interference of external hot source to the sensor]
      C4 --> R4[Replace the main control board of the IDU]
    
```

Note:

1. The inlet air temperature sensor is commonly found in the fresh air IDUs (The sensor code is defined as T0), and its resistance and temperature characteristics are similar to T1 - return air temperature sensor. Please refer to the Table of Temperature Sensor Resistance Characteristics listed in the Maintenance Manual to learn more about the sensor's features.

2.28 dE1 - Sensor control board fault

| | | |
|------------------------|--|--|
| Error display | Digital display | Display position |
| | | Panel, display box, and wired controller |
| Error impact | The faulty IDU and other IDUs of the same system: operate normally. | |
| | ODU of the same system: operate normally. | |
| Error trigger | If the main control board of an IDU has lost communication with sensor control board for 2 min | |
| Error recovery | Automatic recovery | |
| Possible cause | See the Troubleshooting section. | |
| Troubleshooting | <pre> graph LR dE1(dE1) --> C1[Cause 1: The communication cable between the main control board of the IDU and the sensor control board has become disconnected or short circuited] dE1 --> C2[Cause 2: The communication cable between the main control board of IDU and the adapter board has become loose] dE1 --> C3[Cause 3: The IDU main control board is damaged] dE1 --> C4[Cause 4: The sensor control board is damaged] C1 --> A1[Replace the communication cable and properly connect the cable] C2 --> A2[Connect the cable properly] C3 --> A3[Replace the main control board of the IDU] C4 --> A4[Replace the sensor control board] </pre> | |

2.29 dE2 - PM2.5 sensor fault

| | | |
|-----------------|---|--|
| Error display | Digital display | Display position |
| | | Panel, display box, and wired controller |
| Error impact | The faulty IDU and other IDUs of the same system: operate normally. | |
| | ODU of the same system: operate normally. | |
| Error trigger | If the main control board of an IDU has lost communication with PM2.5 sensor for 2 min | |
| Error recovery | Automatic recovery | |
| Possible cause | See the Troubleshooting section. | |
| Troubleshooting | <pre> graph LR dE2(dE2) --> C1[Cause 1: The communication cable between the PM2.5 sensor and the sensor control board becomes disconnected or short circuited] dE2 --> C2[Cause 2: The communication cable between the PM2.5 sensor and the adapter board has become loose] dE2 --> C3[Cause 3: The IDU main control board is damaged] dE2 --> C4[Cause 4: If the error cannot be cleared after causes 1/2/3 have been eliminated, the PM2.5 sensor is damaged] C1 --> R1[Replace the communication cable and properly connect the cable] C2 --> R2[Connect the cable properly] C3 --> R3[Replace the main control board of the IDU] C4 --> R4[Replace the PM2.5 sensor (1)] </pre> | |
| | <p>Note:</p> <p>1. If the PM2.5 sensor is integrated with the sensor control board, making disassembly difficult, then replace the sensor control board directly.</p> | |

2.30 dE3 - CO2 sensor fault

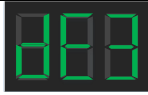
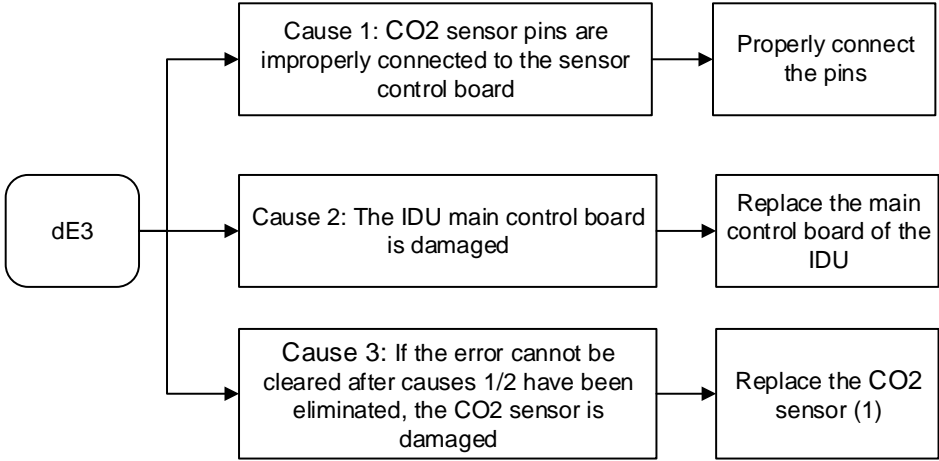
| | | |
|------------------------|--|--|
| Error display | Digital display | Display position |
| |  | Panel, display box, and wired controller |
| Error impact | The faulty IDU and other IDUs of the same system: operate normally. | |
| | ODU of the same system: operate normally. | |
| Error trigger | If the main control board of an IDU has lost communication with CO2 sensor for 2 min | |
| Error recovery | Automatic recovery | |
| Possible cause | See the Troubleshooting section. | |
| Troubleshooting |  <pre> graph LR dE3(dE3) --> C1[Cause 1: CO2 sensor pins are improperly connected to the sensor control board] dE3 --> C2[Cause 2: The IDU main control board is damaged] dE3 --> C3[Cause 3: If the error cannot be cleared after causes 1/2 have been eliminated, the CO2 sensor is damaged] C1 --> S1[Properly connect the pins] C2 --> S2[Replace the main control board of the IDU] C3 --> S3[Replace the CO2 sensor (1)] </pre> | |
| | <p>Note 1:</p> <p>1) The CO2 sensor pins should be inserted on the sensor control board according to the wiring nameplate.</p> <p>2) When inserting and removing the sensor, do not press and deform the sensor surface, as it may change its internal optical path and cause zero drift to the sensor, making the measuring results of sensor too large or even out of range.</p> <p>3) When inserting and removing the sensor: Operators must keep their hands clean and dry; the antistatic wrist strap should be worn on the wrist; the metal piece inside the antistatic wrist strap should be in close contact with the skin; and the metal clamp of the antistatic wrist strap should be placed at the exposed copper grounding wire.</p> | |

2.31 dE4 - Formaldehyde sensor fault

| | | |
|----------------|---|--|
| Error display | Digital display | Display position |
| | | Panel, display box, and wired controller |
| Error impact | The faulty IDU and other IDUs of the same system: operate normally. | |
| | ODU of the same system: operate normally. | |
| Error trigger | If the main control board of an IDU has lost communication with formaldehyde sensor for 2 min | |
| Error recovery | Automatic recovery | |
| Possible cause | See the Troubleshooting section. | |

| | | |
|-----------------|--|--|
| Troubleshooting | <pre> graph LR dE4([dE4]) --> C1[Cause 1: The formaldehyde sensor pins are improperly connected to the sensor control board] dE4 --> C2[Cause 2: The IDU main control board is damaged] dE4 --> C3[Cause 3: If the error cannot be cleared after causes 1/2 have been eliminated, the formaldehyde sensor is damaged] C1 --> R1[Properly connect the pins] C2 --> R2[Replace the main control board of the IDU] C3 --> R3[Replace the formaldehyde sensor (1)] </pre> | |
| | <p>Note 1:</p> <ol style="list-style-type: none"> 1) The formaldehyde sensor pins should be inserted on the sensor control board according to the wiring nameplate. 2) When inserting and removing the sensor, do not touch or squeeze the white sensor film with your hand. 3) When inserting and removing the sensor: Operators must keep their hands clean and dry; the antistatic wrist strap should be worn on the wrist; the metal piece inside the antistatic wrist strap should be in close contact with the skin; and the metal clamp of the antistatic wrist strap should be placed at the exposed copper grounding wire. | |

2.32 dE5 - Human Detect sensor fault

Note: The human detector sensor on the smart panel is used to detect the location of the human body.

| | | |
|-----------------------|--|-------------------------|
| Error display | Digital display | Display position |
| |  | Panel, wired controller |
| Error impact | The faulty IDU and other IDUs of the same system: operate normally. | |
| | ODU of the same system: operate normally. | |
| Error trigger | If the control board of intelligent panel has lost communication with the human detector sensor for 10s and a fault signal has been sent to the IDU main control board | |
| Error recovery | Automatic recovery | |
| Possible cause | See the Troubleshooting section. | |

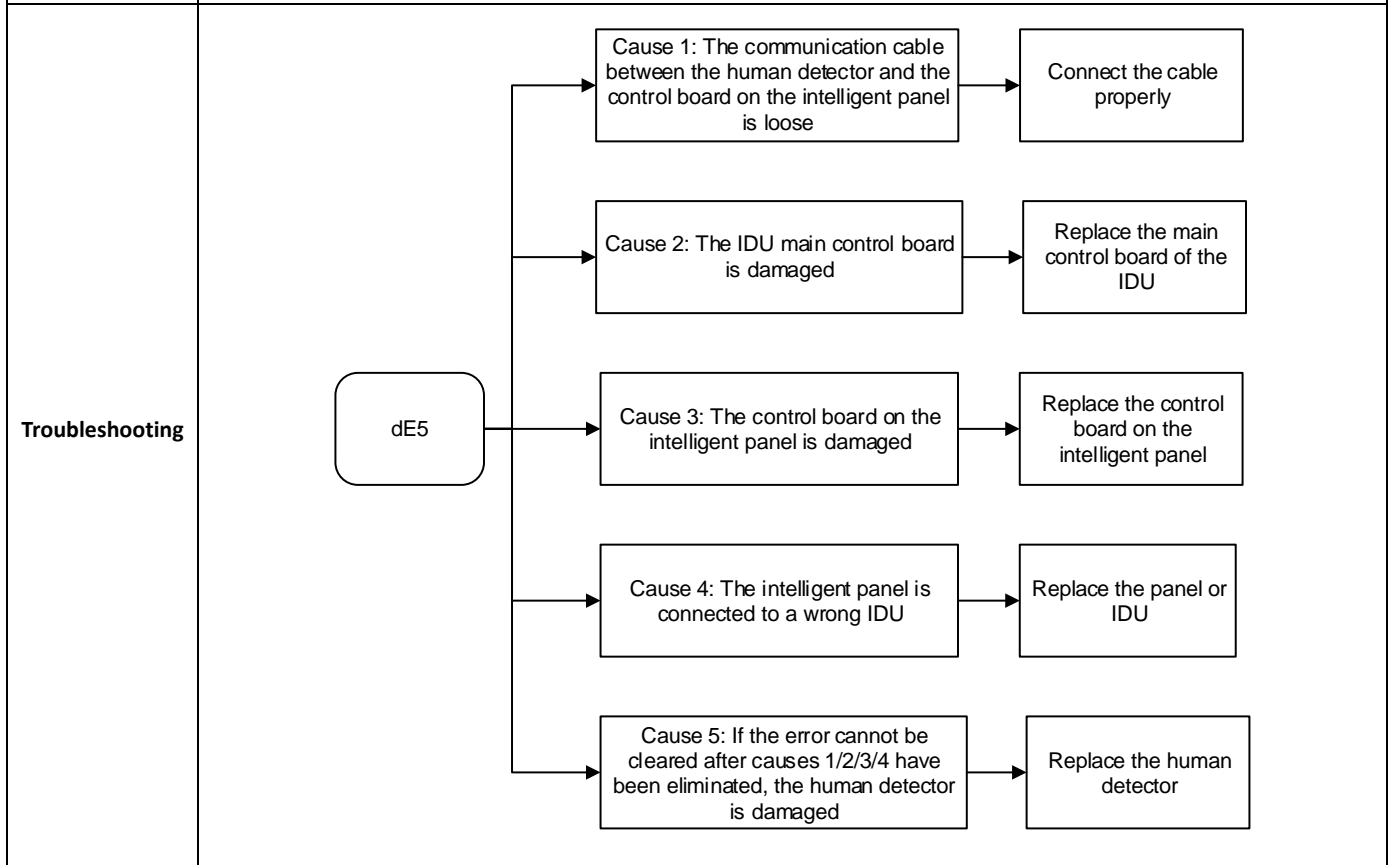

Quantum Series (AU)



2.33 E21, E24, E81 - T0 (fresh inlet air temperature sensor) short-circuits or cuts off, T1 (IDU return air temperature sensor) short-circuits or cuts off, and TA (outlet air temperature sensor) short-circuits or cuts off

| Error display | Digital display | | | Display position |
|----------------|--|--|--|------------------|
| | | | | |
| Error impact | The faulty IDU stops. Other IDUs of the same system: operate normally. | | | |
| | ODU of the same system: operate normally. | | | |
| Error trigger | When detecting that the temperature sensor short-circuits or cuts off | | | |
| Error recovery | Automatic recovery | | | |
| Possible cause | <ul style="list-style-type: none"> ■ The temperature sensor is damaged. ■ The sensor plug to the T0/T1/TA port in the IDU main control board is loose. ■ The IDU main control board is damaged. | | | |

Troubleshooting

```

graph TD
    Start([E21/E24/E81 (1)]) --> Q1{Is the temperature sensor plug connecting to the IDU main control board loose?}
    Q1 -- Yes --> A1[Reconnect the plug tightly]
    Q1 -- No --> Q2{Is the temperature sensor resistance abnormal (2)?}
    Q2 -- Yes --> A2[Replace the temperature sensor]
    Q2 -- No --> A3[Replace the main control board of the IDU]
    
```

Note:

- 1) The E21/E24/E81 code respectively corresponds to the T0/T1/TA temperature sensor. Check the wiring nameplate to find the sensor port on the main control board.
- 2) Measure the resistance between two pins of the sensor plug with a multimeter. A resistance value close to 0 indicates a short circuit has occurred in the temperature sensor, and a resistance value close to infinity indicates an open circuit in the temperature sensor.
- 3) When the AHU kit is set to return air temperature control, it is able to determine if the T1 sensor is short-circuited or open-circuited, but it is not able to determine if the T0 or TA sensors are short-circuited or open-circuited.
- 4) Only the master unit needs to be connected to the T1/T0/TA sensors when the AHU kit is installed in parallel.

2.34 E31: wired controller temperature sensor failure

| | | | |
|------------------------|--|--|------------------|
| Fault Display | LED display | Display position | |
| | | Panel or display box | Wired controller |
| | | Panel, display box, and wired controller | |
| Fault Impact | The faulty IDU and other IDUs of the same system operate normally. ODU of the same system operates normally. | | |
| Fault Trigger | When the V8 series FAPU uses room temperature control, the "Follow Me" temperature value received from the wired controller is abnormal. | | |
| Fault Recovery | Automatic recovery | | |
| Possible Cause | <ul style="list-style-type: none"> ■ The built-in room temperature sensor of the wired controller is short-circuited or open-circuited. ■ The wired controller is damaged. ■ The main control board of the FAPU is damaged. | | |
| Troubleshooting | <div style="text-align: center;"> <pre> graph TD Start([E31]) --> Decision{Is the fault cleared after replacing the wired controller of the same model? (1)} Decision -- Yes --> YesBox[The "Follow Me" temperature sensor embedded in the wired controller is damaged] Decision -- No --> NoBox[Replace the main control board of the IDU] </pre> </div> <p>Note:</p> <p>1. After replacing the wired controller of the same model, set the FAPU to room temperature control and activate the "Follow Me" function according to the engineering parameter settings in the Installation Manual for V8 Series Fresh Air Processing Unit.</p> | | |

2.35 EA2 - Return air humidity sensor fault

| | | | |
|-----------------|---|----------------------------|-----------------------------|
| Error display | Digital display | Display position | |
| | | Panel or display box | Wired controller |
| | | Spot check interface query | Error code is not displayed |
| Error impact | The faulty IDU and other IDUs of the same system: operate normally. ODU of the same system: operate normally. | | |
| Error trigger | If the main control board of an IDU has lost communication with the return air humidity sensor for 2 min | | |
| Error recovery | Automatic recovery | | |
| Possible cause | <ul style="list-style-type: none"> ■ The humidity sensor board is damaged. ■ The cable plug connecting to the RH port in the IDU main control board is loose. ■ The cable plug connecting to the humidity sensor board is loose. ■ The IDU main control board is damaged. | | |
| Troubleshooting | <div style="text-align: center;"> <pre> graph TD Start([EA2]) --> Q1{Is the cable plug (with one end connecting to RH port of the IDU main control board and the other end connecting to humidity sensor board) loose?} Q1 -- Yes --> A1[Reconnect the plug tightly] Q1 -- No --> Q2{Are wires short circuited or disconnected? (1)} Q2 -- Yes --> A2[Replace the wires] Q2 -- No --> Q3{Replace the humidity sensor board and power on the system again. Is the fault cleared?} Q3 -- Yes --> A3[Fault cleared] Q3 -- No --> A4[Replace the main control board of the IDU] </pre> </div> <p>Note:</p> <ol style="list-style-type: none"> 1. Use a multimeter to measure the resistance between the pin in the plug at two ends of each wire. A resistance value close to 0 indicates a short circuit has occurred in the wire, and a resistance value close to infinity indicates an open circuit in the wire. | | |

2.36 EC1: R32 refrigerant leakage sensor fault

| | | |
|------------------------|--|--|
| Fault Display | LED display | Display position |
| | | Panel, display box, and wired controller |
| Fault Impact | Faulty IDU: stops. Other IDUs of the same system: operate normally. | |
| | ODU of the same system operates normally. | |
| Fault Trigger | The IDU main control board receives sensor module fault signal from the R32 refrigerant detection device. | |
| Fault Recovery | No sensor module fault signal is detected by the IDU main control board. | |
| Possible Cause | See the Troubleshooting section. | |
| Troubleshooting | | |
| | <p>Note:</p> <p>1. Three fault resetting methods: sensor module fault, sensor module life expiration, and refrigerant detection device control board EEPROM fault: After faults have been cleared, press and hold the S1 button on the control board for 10 seconds to reset the unit. After resetting, all the LED indicators are lit for two seconds before they become dimmed. The R32 sensor life recorded by the control board EEPROM is cleared. Communication between the sensor and the control board for the detection device is automatically restored.</p> <p>2. The communication connection between the control board for the detection device and the switch module A/B/D is shown in Figure 1 below.</p> | |

Figure 1 Schematic diagram of the R32 refrigerant leakage detection system

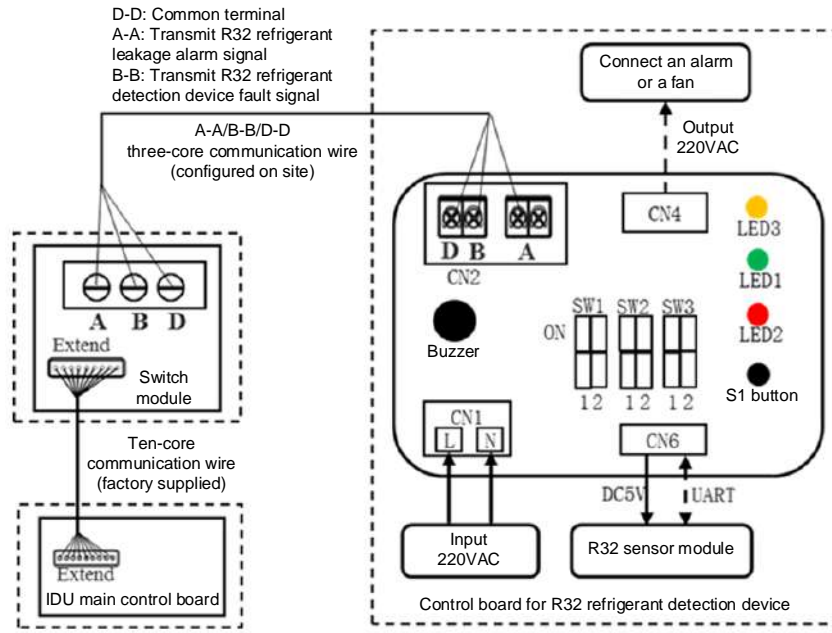

2.37 F01, F11, F21 - T2A (heat exchanger liquid pipe temperature sensor) short-circuits or cuts off, T2 (heat exchanger middle temperature sensor) short-circuits or cuts off, and T2B (heat exchanger gas pipe temperature sensor) short-circuits or cuts off

| | Digital display | Display position |
|-----------------------|---|--|
| Error display |  | Panel, display box, and wired controller |
| Error impact | The faulty IDU stops. Other IDUs of the same system: operate normally. ODU of the same system: operate normally. | |
| Error trigger | When detecting that the temperature sensor short-circuits or cuts off | |
| Error recovery | Automatic recovery | |
| Possible cause | <ul style="list-style-type: none"> ■ The temperature sensor is damaged. ■ The sensor plug connecting to the T2A/T2/T2B port in the IDU main control board is loose. ■ The IDU main control board is damaged. | |

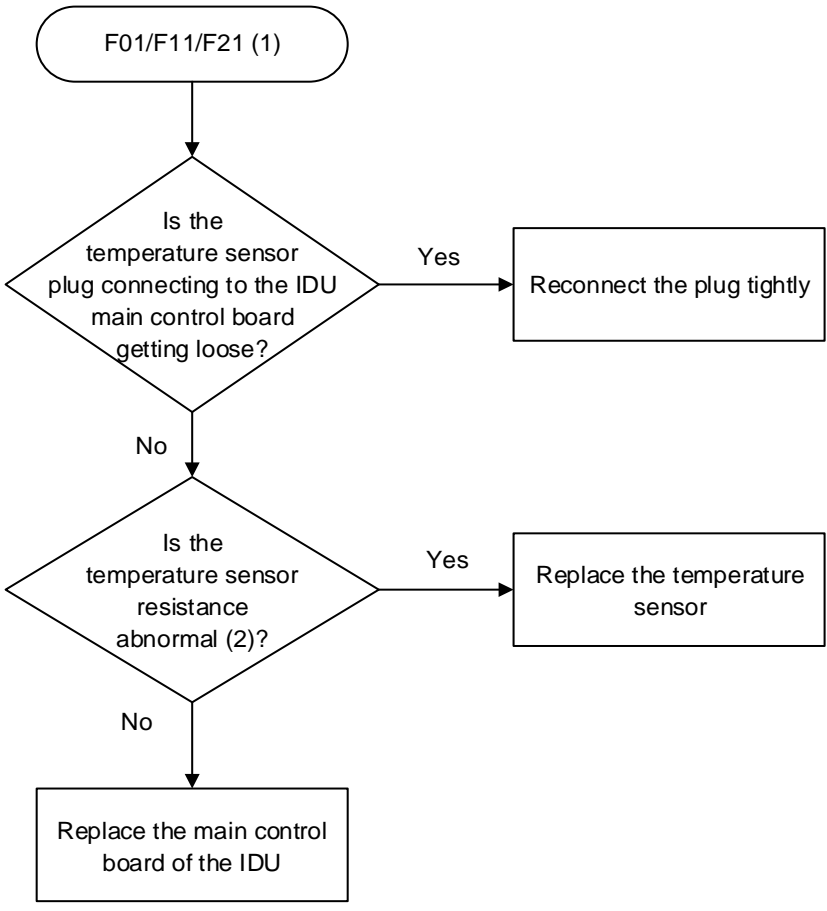
| | |
|------------------------|--|
| Troubleshooting |  <pre> graph TD Start([F01/F11/F21 (1)]) --> D1{Is the temperature sensor plug connecting to the IDU main control board getting loose?} D1 -- Yes --> A1[Reconnect the plug tightly] D1 -- No --> D2{Is the temperature sensor resistance abnormal (2)?} D2 -- Yes --> A2[Replace the temperature sensor] D2 -- No --> A3[Replace the main control board of the IDU] </pre> |
| | <p>Note:</p> <p>1) The F01/F11/F21 codes respectively correspond to T2A/T2/T2B temperature sensors. Check the wiring nameplate to find the sensor port on the main control board.</p> <p>2) Measure the resistance between two pins of the sensor plug with a multimeter. A resistance value close to 0 indicates a short circuit has occurred in the temperature sensor, and a resistance value close to infinity indicates an open circuit in the temperature sensor.</p> <p>3) If only the master unit is connected to the T2A/T2/T2B temperature sensors in the parallel control of the AHU kit, then only the master unit can detect the F01/F11/F21 faults, and the slave units cannot detect them.</p> |

2.38 P31/P34 - Fan drive board AC side overcurrent protection

| Error display | Digital display | | Display position |
|------------------------|---|--|------------------|
| | | | |
| Error impact | The faulty IDU stops. Other IDUs of the same system: operate normally. ODU of the same system: operate normally. | | |
| Error trigger | <ul style="list-style-type: none"> ■ P31: The current value detected on the AC side of the fan drive board exceeds the programmed overcurrent protection value ■ P34: Six P31 failures within an hour. | | |
| Error recovery | <ul style="list-style-type: none"> ■ P31: Automatic recovery ■ P34: Power-on again | | |
| Possible cause | <ul style="list-style-type: none"> ■ The actual static pressure resistance of the indoor unit outlet is less than the static pressure value of indoor unit ■ Instantaneous power failure or violent voltage fluctuation ■ Indoor unit fan driver board is damaged ■ Indoor unit main control board is damaged | | |
| Troubleshooting | <pre> graph LR A(P31/P34) --> B[Cause 1: The actual static pressure resistance of the indoor unit outlet is less than the static pressure value of indoor unit] A --> C[Cause 2: Instantaneous power failure or violent voltage fluctuation] A --> D[Cause 3: If the error cannot be cleared after all other cause have been eliminated, the main control board or fan drive board is damaged] B --> E[Use control to set the static pressure value of indoor unit] C --> F[Power-on again, check whether the power supply voltage is stable, if the fluctuation is violent, the power supply needs to be rectified] D --> G[Replace the main control board or fan drive board] </pre> <p>Note 1: When replacing the fan drive board, the following should be noted: For models where the fan drive board is integrated and soldered onto the main control board, if either the fan drive board or the indoor unit main control board is damaged, the entire control board needs to be replaced."</p> | | |

2.39 P52 - The voltage of the power supply is too low

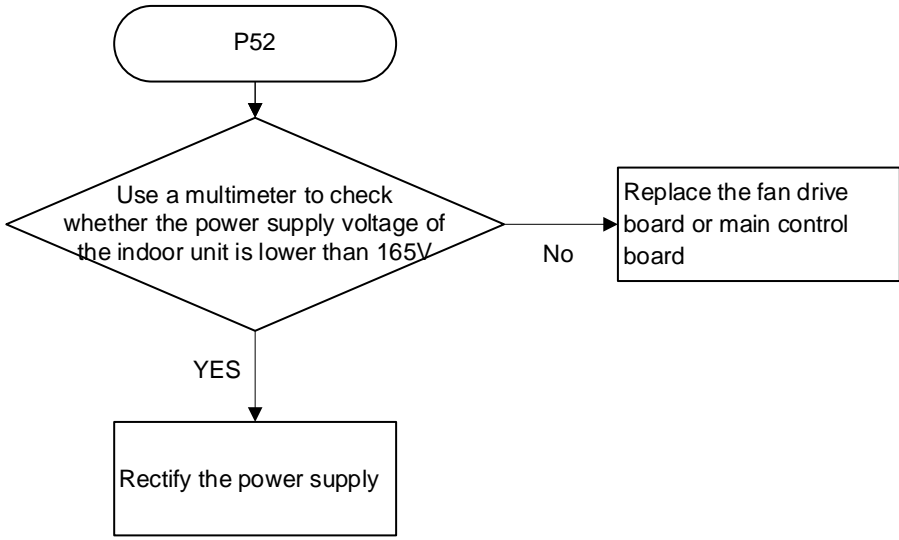
| | | |
|------------------------|---|--|
| Error display | Digital display | Display position |
| |  | Panel, display box, and wired controller |
| Error impact | The faulty IDU stops. Other IDUs of the same system: operate normally. | |
| | ODU of the same system: operate normally. | |
| Error trigger | <ul style="list-style-type: none"> ■ Power supply voltage is below the programmed protection threshold (165V) | |
| Error recovery | <ul style="list-style-type: none"> ■ Automatic recovery | |
| Possible cause | <ul style="list-style-type: none"> ■ Power supply voltage is lower than 165V ■ Indoor unit fan driver board is damaged | |
| Troubleshooting | <div style="text-align: center;">  <pre> graph TD Start([P52]) --> Decision{Use a multimeter to check whether the power supply voltage of the indoor unit is lower than 165V} Decision -- YES --> Rectify[Rectify the power supply] Decision -- No --> Replace[Replace the fan drive board or main control board] </pre> </div> | |

2.40 P71 - Main control board EEPROM fault

| | | |
|-----------------------|---|--|
| Error display | Digital display | Display position |
| | | Panel, display box, and wired controller |
| Error impact | The faulty IDU stops. Other IDUs of the same system: operate normally. | |
| | ODU of the same system: operate normally. | |
| Error trigger | When the master chip cannot receive data from EEPROM (EEPROM: a non-volatile memory whose data are kept even when powered off) | |
| Error recovery | Automatic recovery | |
| Possible cause | <ul style="list-style-type: none"> ■ The IDU main control board is damaged. ■ External interference (such as noise and electromagnetic) | |

| | |
|------------------------|--|
| Troubleshooting | <pre> graph TD Start([P71]) --> Step[Power off and then power on the IDU] Step --> Decision{Is the fault cleared?} Decision -- No --> Action[Replace the main control board of the IDU] Decision -- Yes --> End[The main control board of IDU is normal and subject to external interference (such as noise and electromagnetic)] </pre> |
| | |

2.41 P72 - IDU display control board EEPROM fault

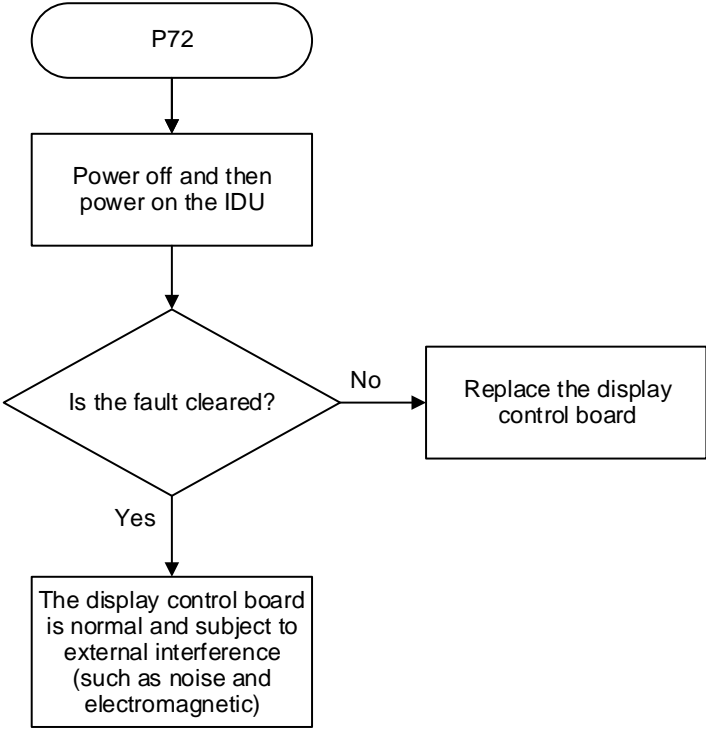
| | | |
|------------------------|--|----------------------|
| Error display | Digital display | Display position |
| |  | Panel or display box |
| Error impact | The faulty IDU operates normally, and the error code is displayed on the panel or display box only. Other IDUs of the same system: operate normally. | |
| | ODU of the same system: operate normally. | |
| Error trigger | Unable to read data from display control board EEPROM (EEPROM: a non-volatile memory whose data are kept even when powered off) | |
| Error recovery | Automatic recovery | |
| Possible cause | <ul style="list-style-type: none"> ■ The display control board is damaged. ■ External interference (such as noise and electromagnetic) | |
| Troubleshooting |  <pre> graph TD Start([P72]) --> Step[Power off and then power on the IDU] Step --> Decision{Is the fault cleared?} Decision -- No --> Action[Replace the display control board] Decision -- Yes --> End[The display control board is normal and subject to external interference (such as noise and electromagnetic)] </pre> | |

Quantum Series (AU)

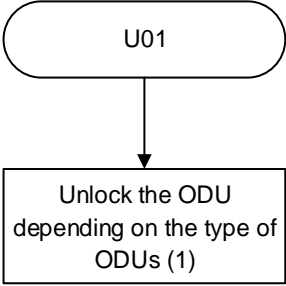

2.42 U01 - Locked (electronic lock)

| | | |
|------------------------|---|--|
| Error display | Digital display | Display position |
| |  | Panel, display box, and wired controller |
| Error impact | All IDUs of the same system: stop running, displaying code "U01" | |
| | ODU of the same system: stops running, displaying code "U01" | |
| Error trigger | When detecting that the ODU is locked | |
| Error recovery | Automatic recovery | |
| Possible cause | The ODU is still locked. | |
| Troubleshooting | <div style="text-align: center;">  <pre> graph TD A([U01]) --> B[Unlock the ODU depending on the type of ODUs (1)] </pre> </div> | |
| | <p>Note 1: To get unlocking methods and tools, please contact your local dealer or technical support personnel.</p> | |

2.43 U11 - Unit model code not set

| Error display | Digital display | Display position |
|------------------------|---|--|
| | | Panel, display box, and wired controller |
| Error impact | 1) The faulty IDU stops running. 2) Other IDUs of the same system: <ul style="list-style-type: none"> ■ If the address for the faulty IDU has been set, other IDUs will operate normally. ■ If the address of the faulty IDU was not set, other IDUs will display error code "A51"-ODU fault. (The indoor unit of V6 platform displays "Ed" code) ODU of the same system: <ul style="list-style-type: none"> ■ If the address for the faulty IDU has been set, the ODU will operate normally. ■ If the address of the faulty IDU was not set, the ODU will display the error code "C26" -number of IDUs reduced. (The outdoor unit of V6 platform displays "H7" code.) | |
| Error trigger | When detecting that the unit model code for IDU main control board is not set | |
| Error recovery | Automatic recovery | |
| Possible cause | <ul style="list-style-type: none"> ■ The unit model code has not been set after replacing the IDU main control board. ■ The IDU main control board is damaged. | |
| Troubleshooting | <div style="text-align: center;"> <pre> graph TD Start([U11]) --> Step[Use the dedicated tooling (1) to set the model code for the main control board of IDU, and power on the unit again] Step --> Decision{Is the fault cleared?} Decision -- No --> Action[Replace the main control board of the IDU] Decision -- Yes --> End[Fault cleared] </pre> </div> <p>Note 1: For specialized tooling and instructions, please contact your local dealer or technical support personnel.</p> | |

2.44 U12 - Capacity(HP) code not set

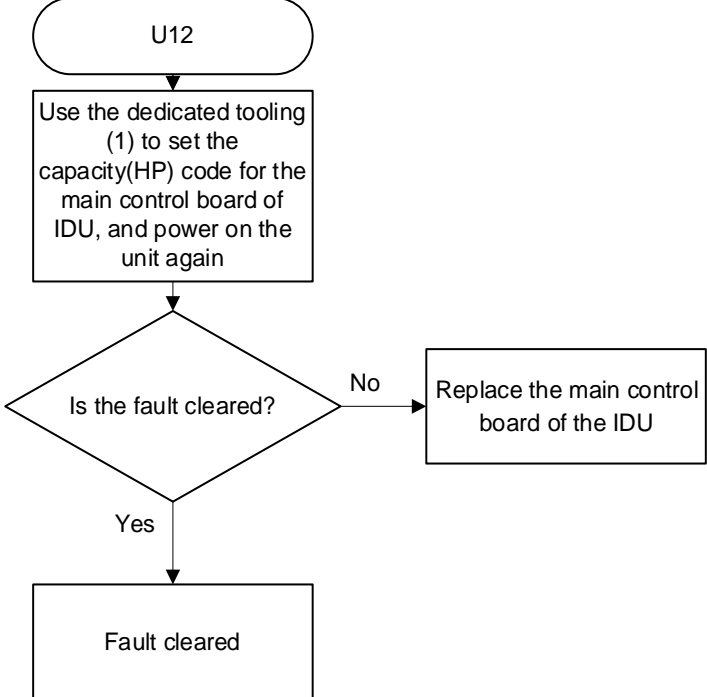
| Error display | Digital display | Display position |
|------------------------|--|--|
| |  | Panel, display box, and wired controller |
| Error impact | <p>1) The faulty IDU stops running.</p> <p>2) Other IDUs of the same system:</p> <ul style="list-style-type: none"> ■ If the address for the faulty IDU has been set, other IDUs will operate normally. ■ If the address of the faulty IDU was not set, other IDUs will display error code "A51"-ODU fault. <p>ODU of the same system:</p> <ul style="list-style-type: none"> ■ If the address for the faulty IDU has been set, the ODU will operate normally. ■ If the address of the faulty IDU was not set, the ODU will display the error code "C26" -number of IDUs reduced. | |
| Error trigger | When detecting that the capacity(HP) code for IDU main control board has not been set | |
| Error recovery | Automatic recovery | |
| Possible cause | <ul style="list-style-type: none"> ■ The capacity(HP) code has not been set after replacing the IDU main control board. ■ The new IDU main control board is damaged. | |
| Troubleshooting | <div style="text-align: center;">  <pre> graph TD Start([U12]) --> Step[Use the dedicated tooling (1) to set the capacity(HP) code for the main control board of IDU, and power on the unit again] Step --> Decision{Is the fault cleared?} Decision -- No --> Action[Replace the main control board of the IDU] Decision -- Yes --> End[Fault cleared] </pre> </div> <p>Note 1: For specialized tooling and instructions, please contact your local dealer or technical support personnel.</p> | |

2.45 U26 - Mismatch between indoor unit model and outdoor unit model

| Error display | Digital display | Display position |
|------------------------|--|--|
| |  | Panel, display box, and wired controller |
| Error impact | 1) The faulty IDU stops running. 2) Other IDUs of the same system will operate normally ODU of the same system: <ul style="list-style-type: none"> ■ If there is one IDU in the system is operating normally, the ODU will operate normally. ■ If all the IDUs in the system are display error code "U26", the ODU will operate normally. | |
| Error trigger | <ul style="list-style-type: none"> ■ There is a conflict between the model series code of indoor unit and the model series code of outdoor unit ■ The communication flag bit (Myhome identification flag bit) between indoor unit and outdoor unit has a matching conflict | |
| Error recovery | Automatic recovery | |
| Possible cause | <ul style="list-style-type: none"> ■ Model series code setting error when replacing the main control board of indoor unit. ■ Mismatch between indoor unit model and outdoor unit model in the same system. ■ Myhome configuration code setting error when replacing the main control board of indoor unit ■ Myhome configuration indoor unit and non-Myhome configuration outdoor unit are connected in one system ■ Non-Myhome configured indoor unit and Myhome configured outdoor unit are connected in one system | |
| Troubleshooting | <div style="display: flex; align-items: center; justify-content: center;"> <div style="border: 1px solid black; border-radius: 15px; padding: 10px; margin-right: 20px;">U26</div> <div style="display: flex; flex-direction: column; gap: 10px;"> <div style="display: flex; align-items: center;"> <div style="border: 1px solid black; padding: 5px; width: 300px;">Cause 1: Model series code setting error when replacing the main control board of indoor unit.</div> <div style="margin-left: 20px;">→</div> <div style="border: 1px solid black; padding: 5px; width: 250px;">Use the dedicated tooling (1) to set the model code for the main control board of IDU, and power on the unit again</div> </div> <div style="display: flex; align-items: center;"> <div style="border: 1px solid black; padding: 5px; width: 300px;">Cause 2: Myhome configuration code setting error when replacing the main control board of indoor unit</div> <div style="margin-left: 20px;">→</div> <div style="border: 1px solid black; padding: 5px; width: 250px;">Use the dedicated tooling (1) to set the Myhome code for the main control board of IDU, and power on the unit again</div> </div> <div style="display: flex; align-items: center;"> <div style="border: 1px solid black; padding: 5px; width: 300px;">Cause 3: Mismatch between indoor unit model and outdoor unit model in the same system.</div> <div style="margin-left: 20px;">→</div> <div style="border: 1px solid black; padding: 5px; width: 250px;">Replace the outdoor unit or indoor unit(2)</div> </div> <div style="display: flex; align-items: center;"> <div style="border: 1px solid black; padding: 5px; width: 300px;">Cause 4: Myhome configuration indoor unit and non-Myhome configuration outdoor unit are connected in one system</div> <div style="margin-left: 20px;">→</div> <div style="border: 1px solid black; padding: 5px; width: 250px;">Replace the outdoor unit or indoor unit(2)</div> </div> <div style="display: flex; align-items: center;"> <div style="border: 1px solid black; padding: 5px; width: 300px;">Cause 5: Non-Myhome configured indoor unit and Myhome configured outdoor unit are connected in one system</div> <div style="margin-left: 20px;">→</div> <div style="border: 1px solid black; padding: 5px; width: 250px;">Replace the outdoor unit or indoor unit(2)</div> </div> </div> </div> <p data-bbox="323 1928 379 1951">Note:</p> <p data-bbox="323 1973 1358 1995">1. For specialized tooling and instructions, please contact your local dealer or technical support personnel.</p> <p data-bbox="323 2018 1114 2040">2. Please contact your local dealer or technical support staff to confirm the detail.</p> | |

2.46 U38 - Address code not detected

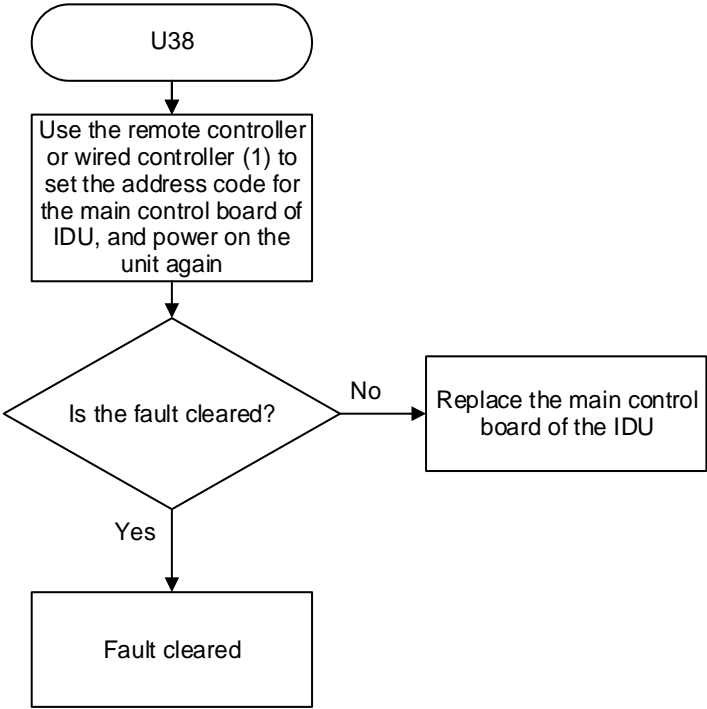
| | Digital display | Display position |
|------------------------|---|--|
| Error display |  | Panel, display box, and wired controller |
| Error impact | 1) The faulty IDU stops running. 2) Other IDUs of the same system: The fan continues running, the EEV is closed, and ODU error code "A51" is displayed (V6 platform IDU displays the code "Ed"). ODU of the same system: Otherwise, the ODU will display the error code "C26" (number of IDUs reduced) (V6 platform ODU displays the code "H7") | |
| Error trigger | When detecting that the address code for IDU main control board has not been set | |
| Error recovery | Automatic recovery | |
| Possible cause | <ul style="list-style-type: none"> ■ The address code has not been set after replacing the IDU main control board. ■ The new IDU main control board is damaged. | |
| Troubleshooting | <div style="text-align: center;">  <pre> graph TD Start([U38]) --> Step[Use the remote controller or wired controller (1) to set the address code for the main control board of IDU, and power on the unit again] Step --> Decision{Is the fault cleared?} Decision -- Yes --> End([Fault cleared]) Decision -- No --> Action[Replace the main control board of the IDU] </pre> </div> <p>Note 1: For instructions on how to set up addresses for a remote controller or a wired controller, please refer to relevant manuals.</p> | |

2.47 J01 - Motor failed more than once

| | | |
|-----------------------|--|--|
| Error display | Digital display | Display position |
| | | Panel, display box, and wired controller |
| Error impact | The faulty IDU stops. Other IDUs of the same system: operate normally. | |
| | ODU of the same system: operate normally. | |
| Error trigger | If fan control faults have occurred 10 times in 120 min (1) | |
| Error recovery | After troubleshooting, power on again | |
| Possible cause | The fan drive faults have caused the motor to fail more than once. | |

| Troubleshooting | <div style="text-align: center;"> <pre> graph TD A([J01 (1)]) --> B[Enter the spot check interface of the IDU to view the fan error code] B --> C[Take relevant countermeasures according to the error code] C --> D[If the fault persists, please contact the technical support personnel of your dealer] </pre> </div> <p>Note:</p> <p>1. Enter the spot check interface of the IDU to query fan drive fault code (see the table below). For specific troubleshooting methods, please refer to this document.</p> <table border="1" style="margin-left: auto; margin-right: auto;"> <thead> <tr> <th>No.</th> <th>Error code</th> <th>Fan drive fault name</th> </tr> </thead> <tbody> <tr> <td>1</td> <td>J1E</td> <td>IPM (fan module) overcurrent protection</td> </tr> <tr> <td>2</td> <td>J11</td> <td>Instantaneous overcurrent protection for phase</td> </tr> <tr> <td>3</td> <td>J3E</td> <td>Low bus voltage fault</td> </tr> <tr> <td>4</td> <td>J31</td> <td>High bus voltage fault</td> </tr> <tr> <td>5</td> <td>J43</td> <td>Phase current sample bias error</td> </tr> <tr> <td>6</td> <td>J47</td> <td>IPM (fan module) and IDU unmatched</td> </tr> <tr> <td>7</td> <td>J5E</td> <td>Motor startup failure</td> </tr> <tr> <td>8</td> <td>J52</td> <td>Motor blocking protection</td> </tr> <tr> <td>9</td> <td>J55</td> <td>Speed control mode setting error</td> </tr> <tr> <td>10</td> <td>J6E</td> <td>Phase lack protection of motor</td> </tr> </tbody> </table> | No. | Error code | Fan drive fault name | 1 | J1E | IPM (fan module) overcurrent protection | 2 | J11 | Instantaneous overcurrent protection for phase | 3 | J3E | Low bus voltage fault | 4 | J31 | High bus voltage fault | 5 | J43 | Phase current sample bias error | 6 | J47 | IPM (fan module) and IDU unmatched | 7 | J5E | Motor startup failure | 8 | J52 | Motor blocking protection | 9 | J55 | Speed control mode setting error | 10 | J6E | Phase lack protection of motor |
|------------------------|---|--|----------------------|----------------------|---|-----|---|---|-----|--|---|-----|-----------------------|---|-----|------------------------|---|-----|---------------------------------|---|-----|------------------------------------|---|-----|-----------------------|---|-----|---------------------------|---|-----|----------------------------------|----|-----|--------------------------------|
| | No. | Error code | Fan drive fault name | | | | | | | | | | | | | | | | | | | | | | | | | | | | | | | |
| 1 | J1E | IPM (fan module) overcurrent protection | | | | | | | | | | | | | | | | | | | | | | | | | | | | | | | | |
| 2 | J11 | Instantaneous overcurrent protection for phase | | | | | | | | | | | | | | | | | | | | | | | | | | | | | | | | |
| 3 | J3E | Low bus voltage fault | | | | | | | | | | | | | | | | | | | | | | | | | | | | | | | | |
| 4 | J31 | High bus voltage fault | | | | | | | | | | | | | | | | | | | | | | | | | | | | | | | | |
| 5 | J43 | Phase current sample bias error | | | | | | | | | | | | | | | | | | | | | | | | | | | | | | | | |
| 6 | J47 | IPM (fan module) and IDU unmatched | | | | | | | | | | | | | | | | | | | | | | | | | | | | | | | | |
| 7 | J5E | Motor startup failure | | | | | | | | | | | | | | | | | | | | | | | | | | | | | | | | |
| 8 | J52 | Motor blocking protection | | | | | | | | | | | | | | | | | | | | | | | | | | | | | | | | |
| 9 | J55 | Speed control mode setting error | | | | | | | | | | | | | | | | | | | | | | | | | | | | | | | | |
| 10 | J6E | Phase lack protection of motor | | | | | | | | | | | | | | | | | | | | | | | | | | | | | | | | |

2.48 J1E: IPM (fan module) overcurrent protection

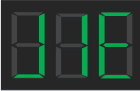
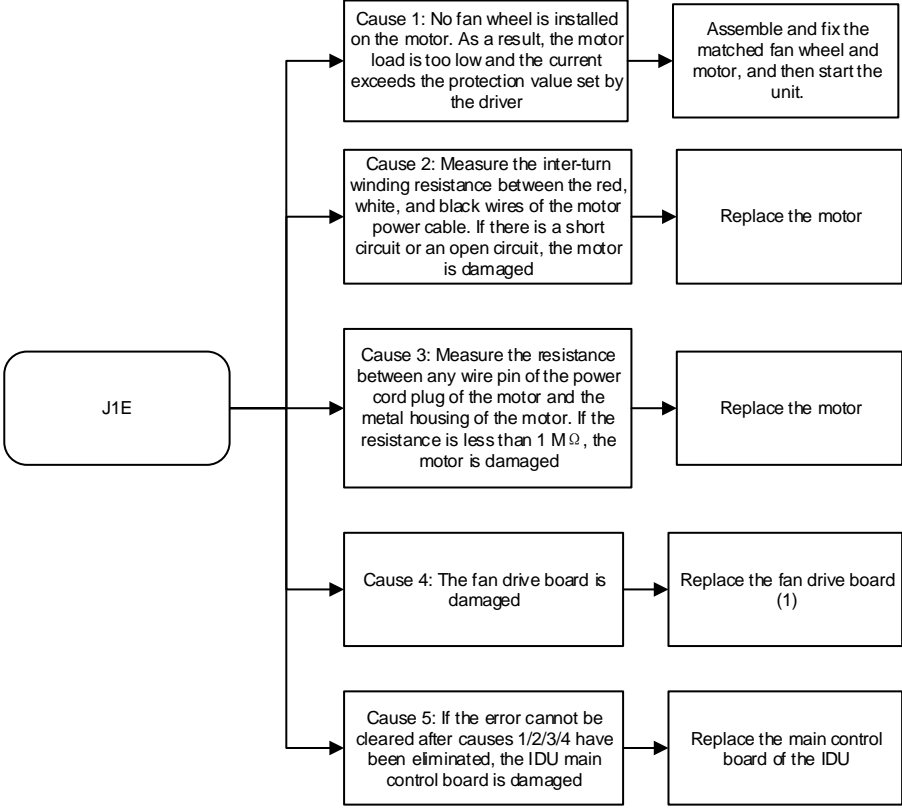
| | | |
|------------------------|--|---|
| Fault Display | <p style="text-align: center;">LED display</p> <div style="text-align: center;">  </div> | <p style="text-align: center;">Display position</p> <p style="text-align: center;">Panel, display box, and wired controller</p> |
| Fault Impact | <p>The faulty IDU stops. Other IDUs of the same system: operate normally.</p> <p>ODU of the same system operates normally.</p> | |
| Fault Trigger | <p>The fault is triggered if one of the following conditions is met:</p> <p>1) The current value (AC) detected for any phase line of U/V/W on the IPM exceeds the set overcurrent protection value of the IPM.</p> <p>2) A fault signal output by the IPM protection circuit is detected.</p> | |
| Fault Recovery | <p>Automatic recovery</p> | |
| Possible Cause | <ul style="list-style-type: none"> ■ There is no fan wheel installed on the motor. ■ The motor insulation is damaged or motor coils are short-circuited. ■ The fan drive board is damaged. ■ The IDU main control board is damaged. | |
| Troubleshooting | <div style="text-align: center;">  </div> <p>Note 1: Please observe the following rule when replacing the fan drive board: For units whose fan drive board is welded onto the main control board, if either the fan drive board or main control board becomes faulty, the whole control board has to be replaced.</p> | |



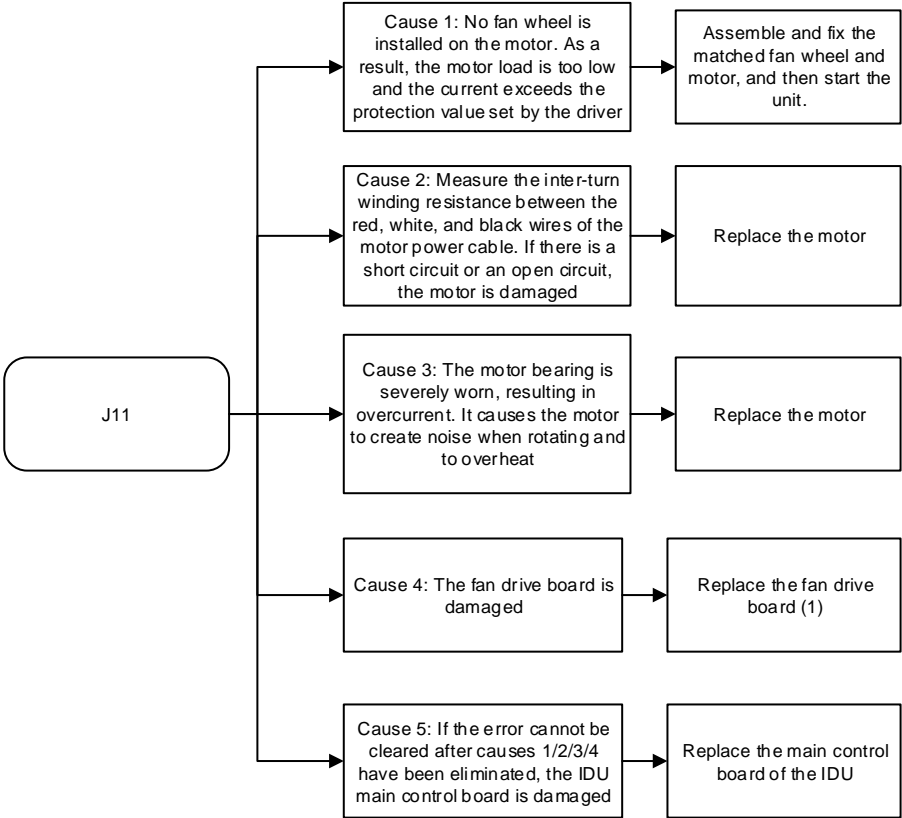



2.49 J11: instantaneous overcurrent protection for phase current

| | | |
|------------------------|---|--|
| Fault Display | LED display | Display position |
| |  | Panel, display box, and wired controller |
| Fault Impact | The faulty IDU stops. Other IDUs of the same system: operate normally. ODU of the same system operates normally. | |
| Fault Trigger | The current value (AC) detected for any phase line of U/V/W on the IPM exceeds the set overcurrent protection value of the driver. | |
| Fault Recovery | Automatic recovery | |
| Possible Cause | <ul style="list-style-type: none"> ■ There is no fan wheel installed on the motor. ■ Motor coils are short-circuited, or the motor bearing is worn, resulting in an abnormal increase of motor current. ■ The fan drive board is damaged. ■ The IDU main control board is damaged. | |
| Troubleshooting | <div style="text-align: center;">  <pre> graph LR J11((J11)) --> C1[Cause 1: No fan wheel is installed on the motor. As a result, the motor load is too low and the current exceeds the protection value set by the driver] J11 --> C2[Cause 2: Measure the inter-turn winding resistance between the red, white, and black wires of the motor power cable. If there is a short circuit or an open circuit, the motor is damaged] J11 --> C3[Cause 3: The motor bearing is severely worn, resulting in overcurrent. It causes the motor to create noise when rotating and to over heat] J11 --> C4[Cause 4: The fan drive board is damaged] J11 --> C5[Cause 5: If the error cannot be cleared after causes 1/2/3/4 have been eliminated, the IDU main control board is damaged] C1 --> A1[Assemble and fix the matched fan wheel and motor, and then start the unit.] C2 --> A2[Replace the motor] C3 --> A3[Replace the motor] C4 --> A4[Replace the fan drive board (1)] C5 --> A5[Replace the main control board of the IDU] </pre> </div> <p>Note 1: Please observe the following rule when replacing the fan drive board: For units whose fan drive board is welded onto the main control board, if either the fan drive board or main control board becomes faulty, the whole control board has to be replaced.</p> | |

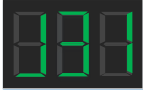
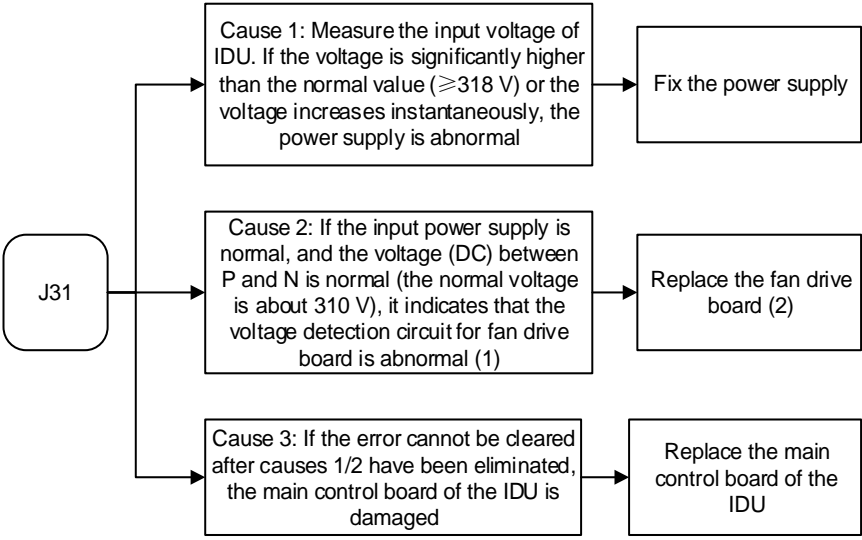
2.50 J3E - Low bus voltage fault

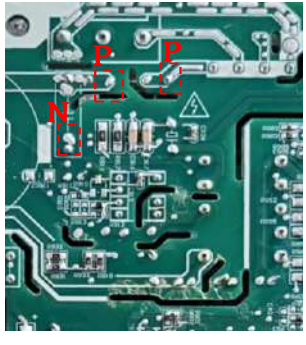
| Error display | Digital display | Display position | | | | | | | | | |
|-----------------|---|-----------------------------------|-----------------------------|------------|------------|--|------------------------------------|-----------------------------------|--|--|--|
| | | Panel or display box | Wired controller | | | | | | | | |
| | | Spot check interface query | Error code is not displayed | | | | | | | | |
| Error impact | The faulty IDU stops. Other IDUs of the same system: operate normally. ODU of the same system: operate normally. | | | | | | | | | | |
| Error trigger | When the bus voltage (DC voltage) is below the threshold value of the driver (165 V) | | | | | | | | | | |
| Error recovery | Automatic recovery | | | | | | | | | | |
| Possible cause | <ul style="list-style-type: none"> ■ The input voltage is too low, resulting in low bus voltage. ■ The input voltage encounters transient drop and interruption, resulting in too low transient bus voltage. ■ The fan drive board is damaged, so the bus voltage detection circuit becomes abnormal. ■ The IDU main control board is damaged. | | | | | | | | | | |
| Troubleshooting | <div style="text-align: center;"> </div> <p>Note:</p> <p>1. Please refer to the figure below when measuring voltage between P and N. Make sure P/N measuring points are selected according to PCB type.</p> <table border="1" style="width: 100%; text-align: center;"> <thead> <tr> <th rowspan="2">PCB type 1</th> <th colspan="2">PCB type 2</th> </tr> <tr> <th>P/N measuring point (front of PCB)</th> <th>P/N measuring point (back of PCB)</th> </tr> </thead> <tbody> <tr> <td></td> <td></td> <td></td> </tr> </tbody> </table> <p>2. Please observe the following rule when replacing the fan drive board: For units whose fan drive board is welded onto the main control board, if either the fan drive board or main control board becomes faulty, the whole control board has to be replaced.</p> | | | PCB type 1 | PCB type 2 | | P/N measuring point (front of PCB) | P/N measuring point (back of PCB) | | | |
| PCB type 1 | PCB type 2 | | | | | | | | | | |
| | P/N measuring point (front of PCB) | P/N measuring point (back of PCB) | | | | | | | | | |
| | | | | | | | | | | | |

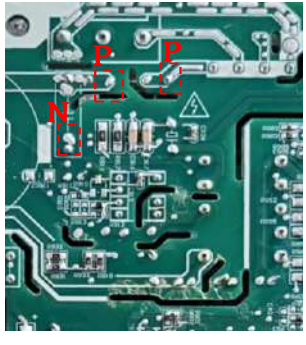
2.51 J31 - High bus voltage fault

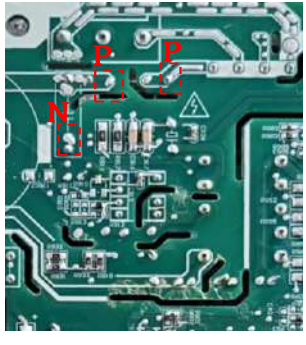
| Error display | Digital display | Display position | | | | | | | | | |
|---|--|---|------------|------------|--|---------------------|------------------------------------|-----------------------------------|---|--|---|
| |  | Panel, display box Wired controller | | | | | | | | | |
| Error impact | The faulty IDU stops. Other IDUs of the same system: operate normally. | | | | | | | | | | |
| | ODU of the same system: operate normally. | | | | | | | | | | |
| Error trigger | When the bus voltage (DC voltage) is greater than the threshold value of the driver (450V) | | | | | | | | | | |
| Error recovery | Automatic recovery | | | | | | | | | | |
| Possible cause | <ul style="list-style-type: none"> ■ The input voltage is too high, resulting in high bus voltage. ■ Instantaneous high input voltage. ■ The fan drive board is damaged, so the bus voltage detection circuit becomes abnormal. ■ The IDU main control board is damaged. | | | | | | | | | | |
| Troubleshooting | <div style="text-align: center;">  </div> <p>Note:</p> <p>1. Please refer to the figure below when measuring voltage between P and N. Make sure P/N measuring points are selected according to PCB type.</p> <table border="1" style="width: 100%; text-align: center;"> <thead> <tr> <th style="width: 33%;">PCB type 1</th> <th colspan="2">PCB type 2</th> </tr> <tr> <th>P/N measuring point</th> <th>P/N measuring point (front of PCB)</th> <th>P/N measuring point (back of PCB)</th> </tr> </thead> <tbody> <tr> <td></td> <td></td> <td></td> </tr> </tbody> </table> <p>2. Please observe the following rule when replacing the fan drive board: For units whose fan drive board is welded onto the main control board, if either the fan drive board or main control board becomes faulty, the whole control board has to be replaced.</p> | | PCB type 1 | PCB type 2 | | P/N measuring point | P/N measuring point (front of PCB) | P/N measuring point (back of PCB) |  |  |  |
| | PCB type 1 | PCB type 2 | | | | | | | | | |
| P/N measuring point | P/N measuring point (front of PCB) | P/N measuring point (back of PCB) | | | | | | | | | |
|  |  |  | | | | | | | | | |

2.52 J43 - Phase current sample bias error

| | | |
|-----------------|---|--|
| Error display | Digital display | Display position |
| | | Panel, display box Wired controller |
| Error impact | The faulty IDU stops. Other IDUs of the same system: operate normally. | |
| | ODU of the same system: operate normally. | |
| Error trigger | When detecting that the current sample is 50% greater than 2.5 V | |
| Error recovery | Automatic recovery | |
| Possible cause | <ul style="list-style-type: none"> ■ The current sampling circuit of the fan drive board is damaged. ■ The IDU main control board is damaged. | |
| Troubleshooting | <div style="text-align: center;"> <pre> graph TD J11([J11]) --> D{Replace the fan drive board. Is the fault cleared?} D -- Yes --> A1[Replace the fan drive board (1)] D -- No --> A2[Replace the main control board of the IDU] </pre> </div> <p>Note 1: Please observe the following rule when replacing the fan drive board: For units whose fan drive board is welded onto the main control board, if either the fan drive board or main control board becomes faulty, the whole control board has to be replaced.</p> | |

2.53 J45 - Motor and IDU unmatched

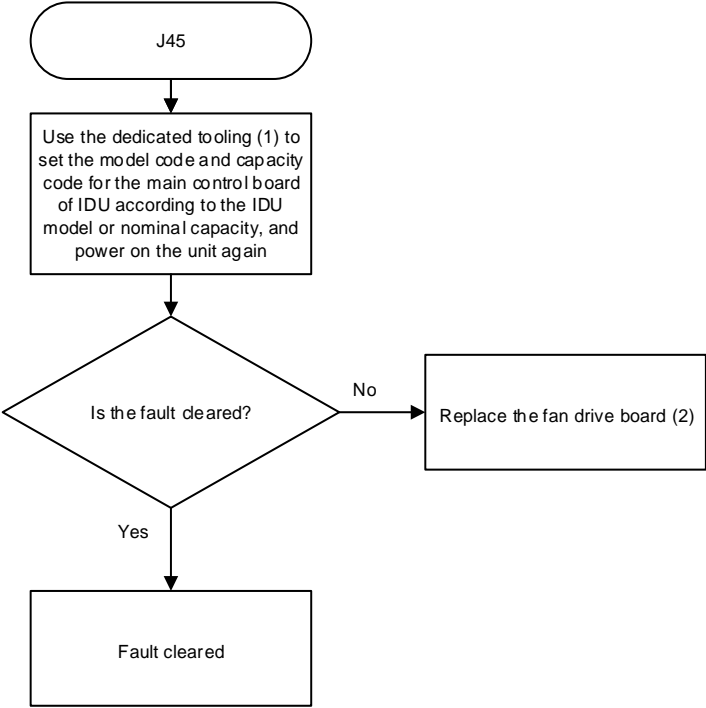
| Error display | Digital display | Display position |
|------------------------|--|--|
| |  | Panel, display box, and wired controller |
| Error impact | The faulty IDU stops. Other IDUs of the same system: operate normally. ODU of the same system: operate normally. | |
| Error trigger | If the motor code sent by the IDU main control board is not found in the fan driver | |
| Error recovery | Automatic recovery | |
| Possible cause | <ul style="list-style-type: none"> ■ Unit model code or capacity code is incorrectly set. ■ The fan drive board is wrong or damaged. | |
| Troubleshooting | <div style="text-align: center;">  <pre> graph TD Start([J45]) --> Step[Use the dedicated tooling (1) to set the model code and capacity code for the main control board of IDU according to the IDU model or nominal capacity, and power on the unit again] Step --> Decision{Is the fault cleared?} Decision -- Yes --> End([Fault cleared]) Decision -- No --> Action[Replace the fan drive board (2)] </pre> </div> <p>Note:</p> <ol style="list-style-type: none"> 1. For specialized tooling and instructions, please contact your local dealer or technical support personnel. 2. Please observe the following rule when replacing the fan drive board: For units whose fan drive board is welded onto the main control board, if either the fan drive board or main control board becomes faulty, the whole control board has to be replaced. | |

Quantum Series (AU)



2.54 J47 - IPM (fan module) and IDU unmatched

| | | |
|----------------|--|--|
| Error display | Digital display | Display position |
| | | Panel, display box, and wired controller |
| Error impact | The faulty IDU stops. Other IDUs of the same system: operate normally. | |
| | ODU of the same system: operate normally. | |
| Error trigger | When detecting that the fan drive board does not match the set value of the driver | |
| Error recovery | Automatic recovery | |
| Possible cause | <ul style="list-style-type: none"> ■ Unit model code or capacity(HP) code is incorrectly set. ■ The fan drive board is wrong or damaged. | |

Troubleshooting

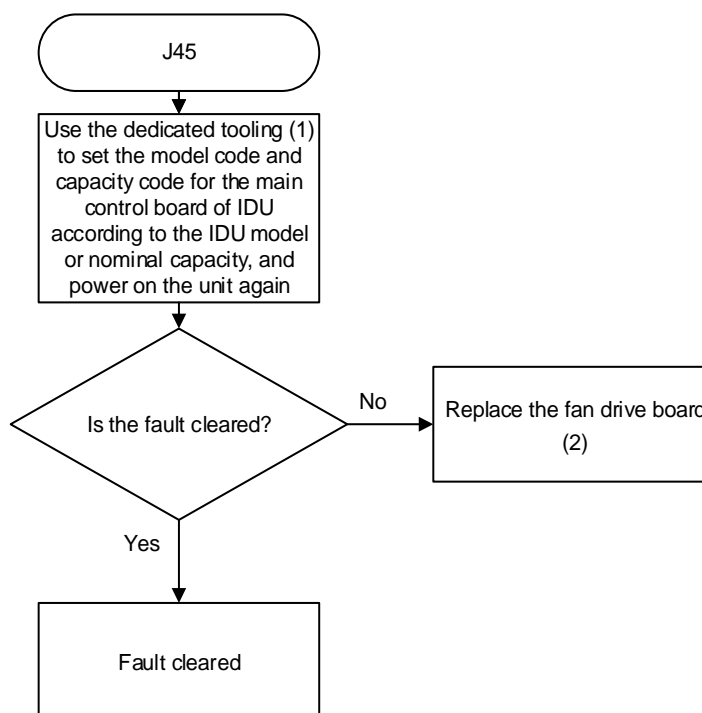

Note:

1. For specialized tooling and instructions, please contact your local dealer or technical support personnel.
2. Please observe the following rule when replacing the fan drive board: For units whose fan drive board is welded onto the main control board, if either the fan drive board or main control board becomes faulty, the whole control board has to be replaced.

2.55 J5E - Motor startup failure

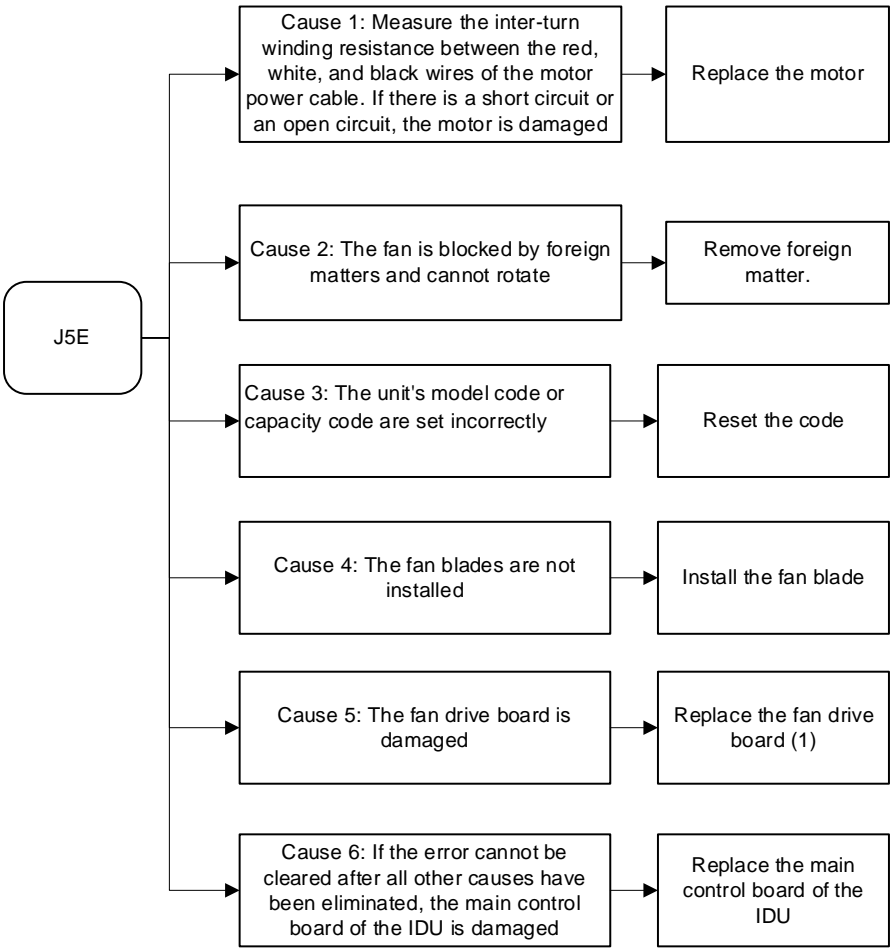
| | | |
|------------------------|--|--|
| Error display | Digital display | Display position |
| |  | Panel, display box Wired controller |
| Error impact | The faulty IDU stops. Other IDUs of the same system: operate normally. | |
| | ODU of the same system: operate normally. | |
| Error trigger | Motor startup failure | |
| Error recovery | Automatic recovery | |
| Possible cause | <ul style="list-style-type: none"> ■ Motor winding short-circuits or cuts off ■ The fan is blocked by foreign material or the motor is damaged and cannot rotate. ■ The unit's model code or capacity code are set incorrectly ■ Fan blade is not installed ■ The fan drive module is damaged. ■ The IDU main control board is damaged. | |
| Troubleshooting | <div style="text-align: center;">  <pre> graph LR J5E((J5E)) --> C1[Cause 1: Measure the inter-turn winding resistance between the red, white, and black wires of the motor power cable. If there is a short circuit or an open circuit, the motor is damaged] J5E --> C2[Cause 2: The fan is blocked by foreign matters and cannot rotate] J5E --> C3[Cause 3: The unit's model code or capacity code are set incorrectly] J5E --> C4[Cause 4: The fan blades are not installed] J5E --> C5[Cause 5: The fan drive board is damaged] J5E --> C6[Cause 6: If the error cannot be cleared after all other causes have been eliminated, the main control board of the IDU is damaged] C1 --> A1[Replace the motor] C2 --> A2[Remove foreign matter.] C3 --> A3[Reset the code] C4 --> A4[Install the fan blade] C5 --> A5[Replace the fan drive board (1)] C6 --> A6[Replace the main control board of the IDU] </pre> </div> <p>Note 1: Please observe the following rule when replacing the fan drive board: For units whose fan drive board is welded onto the main control board, if either the fan drive board or main control board becomes faulty, the whole control board has to be replaced.</p> | |

2.56 J52: motor blocking protection

| | | |
|------------------------|--|--|
| Fault Display | LED display | Display position |
| | | Panel, display box, and wired controller |
| Fault Impact | The faulty IDU stops. Other IDUs of the same system: operate normally. ODU of the same system operates normally. | |
| Fault Trigger | The motor is blocked. | |
| Fault Recovery | Automatic recovery | |
| Possible Cause | <ul style="list-style-type: none"> ■ There is no fan wheel installed on the motor. ■ The motor shaft gets stuck. ■ The fan drive board is damaged. ■ The IDU main control board is damaged. | |
| Troubleshooting | <div style="text-align: center;"> </div> <p>Note 1: Please observe the following rule when replacing the fan drive board: For units whose fan drive board is welded onto the main control board, if either the fan drive board or main control board becomes faulty, the whole control board has to be replaced.</p> | |

2.57 J55 - Speed control mode setting error

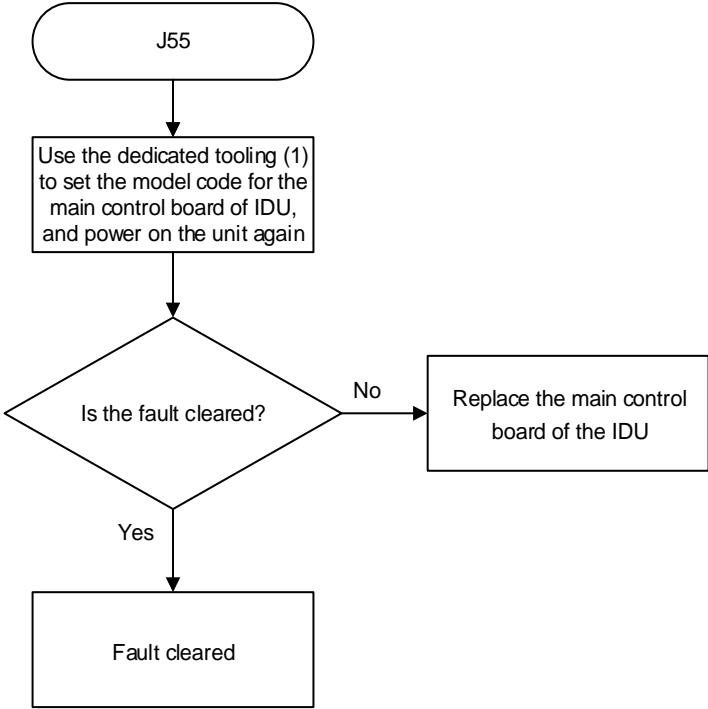
| | | |
|-----------------------|--|---|
| Error display | Digital display | Display position |
| |  | Panel, display box Wired controller |
| Error impact | The faulty IDU stops. Other IDUs of the same system: operate normally. | |
| | ODU of the same system: operate normally. | |
| Error trigger | The IDU is non constant air flow control, but its main control program sets the fan speed according to the constant air flow control mode. | |
| Error recovery | Automatic recovery | |
| Possible cause | <ul style="list-style-type: none"> ■ The IDU model is set incorrectly. ■ The IDU main control board is damaged. | |
| | Troubleshooting | <div style="text-align: center;">  <pre> graph TD Start([J55]) --> Step[Use the dedicated tooling (1) to set the model code for the main control board of IDU, and power on the unit again] Step --> Decision{Is the fault cleared?} Decision -- No --> Action[Replace the main control board of the IDU] Decision -- Yes --> End[Fault cleared] </pre> </div> <p>Note 1: For specialized tooling and instructions, please contact your local dealer or technical support personnel.</p> |

2.58 J6E - Phase lack protection of motor

| | | |
|-----------------|---|--|
| Error display | Digital display | Display position |
| | | Panel, display box Wired controller |
| Error impact | The faulty IDU stops. Other IDUs of the same system: operate normally. | |
| | ODU of the same system: operate normally. | |
| Error trigger | When the motor phase lacks protection | |
| Error recovery | Automatic recovery | |
| Possible cause | <ul style="list-style-type: none"> ■ The motor plug connecting to the U/V/W port in the IDU main control board is loose. ■ The fan drive board is damaged. ■ The IDU main control board is damaged. | |
| Troubleshooting | <p>Note 1: Please observe the following rule when replacing the fan drive board: For units whose fan drive board is welded onto the main control board, if either the fan drive board or main control board becomes faulty, the whole control board has to be replaced.</p> | |

3 Appendix

3.1 Temperature Sensor Resistance Characteristics

Table 9.1: Indoor temperature sensors resistance characteristics

R25=10KΩ±3% B25/50=4100K±3%

| Temperature (°C) | Resistance min(kΩ) | Resistance Normal(kΩ) | Resistance max(kΩ) | Temperature (°C) | Resistance min(kΩ) | Resistance Normal(kΩ) | Resistance max(kΩ) |
|------------------|--------------------|-----------------------|--------------------|------------------|--------------------|-----------------------|--------------------|
| -40 | 337.762 | 388.619 | 446.732 | 0 | 32.140 | 34.385 | 36.753 |
| -39 | 315.441 | 362.171 | 415.450 | 1 | 30.532 | 32.613 | 34.803 |
| -38 | 294.802 | 337.767 | 386.646 | 2 | 29.013 | 30.941 | 32.968 |
| -37 | 275.699 | 315.226 | 360.096 | 3 | 27.578 | 29.364 | 31.238 |
| -36 | 258.001 | 294.386 | 335.600 | 4 | 26.221 | 27.876 | 29.609 |
| -35 | 241.589 | 275.100 | 312.977 | 5 | 24.938 | 26.471 | 28.074 |
| -34 | 226.358 | 257.238 | 292.067 | 6 | 23.725 | 25.145 | 26.626 |
| -33 | 212.210 | 240.679 | 272.721 | 7 | 22.578 | 23.892 | 25.260 |
| -32 | 199.059 | 225.317 | 254.809 | 8 | 21.492 | 22.708 | 23.972 |
| -31 | 186.823 | 211.053 | 238.210 | 9 | 20.464 | 21.590 | 22.757 |
| -30 | 175.432 | 197.799 | 222.817 | 10 | 19.491 | 20.532 | 21.609 |
| -29 | 164.820 | 185.475 | 208.531 | 11 | 18.569 | 19.532 | 20.526 |
| -28 | 154.925 | 174.007 | 195.264 | 12 | 17.696 | 18.586 | 19.502 |
| -27 | 145.695 | 163.330 | 182.934 | 13 | 16.868 | 17.690 | 18.536 |
| -26 | 137.078 | 153.381 | 171.467 | 14 | 16.084 | 16.843 | 17.622 |
| -25 | 129.030 | 144.105 | 160.797 | 15 | 15.341 | 16.041 | 16.758 |
| -24 | 121.508 | 135.452 | 150.861 | 16 | 14.635 | 15.281 | 15.941 |
| -23 | 114.473 | 127.375 | 141.604 | 17 | 13.966 | 14.562 | 15.169 |
| -22 | 107.892 | 119.832 | 132.974 | 18 | 13.332 | 13.880 | 14.438 |
| -21 | 101.730 | 112.783 | 124.925 | 19 | 12.729 | 13.234 | 13.746 |
| -20 | 95.959 | 106.193 | 117.413 | 20 | 12.157 | 12.621 | 13.091 |
| -19 | 90.551 | 100.028 | 110.399 | 21 | 11.614 | 12.041 | 12.471 |
| -18 | 85.480 | 94.259 | 103.846 | 22 | 11.099 | 11.490 | 11.884 |
| -17 | 80.724 | 88.857 | 97.721 | 23 | 10.608 | 10.967 | 11.327 |
| -16 | 76.260 | 83.796 | 91.994 | 24 | 10.143 | 10.471 | 10.800 |
| -15 | 72.070 | 79.054 | 86.636 | 25 | 9.700 | 10.000 | 10.300 |
| -14 | 68.134 | 74.607 | 81.620 | 26 | 9.254 | 9.553 | 9.853 |
| -13 | 64.436 | 70.436 | 76.924 | 27 | 8.830 | 9.128 | 9.428 |
| -12 | 60.960 | 66.521 | 72.525 | 28 | 8.429 | 8.725 | 9.024 |
| -11 | 57.691 | 62.847 | 68.402 | 29 | 8.048 | 8.342 | 8.639 |
| -10 | 54.615 | 59.396 | 64.536 | 30 | 7.686 | 7.977 | 8.273 |
| -9 | 51.721 | 56.153 | 60.911 | 31 | 7.342 | 7.631 | 7.924 |
| -8 | 48.996 | 53.106 | 57.509 | 32 | 7.016 | 7.302 | 7.592 |
| -7 | 46.430 | 50.241 | 54.315 | 33 | 6.706 | 6.988 | 7.276 |
| -6 | 44.012 | 47.546 | 51.317 | 34 | 6.412 | 6.690 | 6.975 |
| -5 | 41.733 | 45.010 | 48.500 | 35 | 6.132 | 6.407 | 6.688 |
| -4 | 39.585 | 42.623 | 45.853 | 36 | 5.866 | 6.137 | 6.414 |
| -3 | 37.558 | 40.376 | 43.365 | 37 | 5.613 | 5.880 | 6.153 |
| -2 | 35.647 | 38.259 | 41.025 | 38 | 5.373 | 5.635 | 5.905 |
| -1 | 33.843 | 36.264 | 38.824 | 39 | 5.144 | 5.402 | 5.667 |

Table 9.1: Indoor temperature sensors resistance characteristics (continued)

| Temperature (°C) | Resistance min(kΩ) | Resistance Normal(kΩ) | Resistance max(kΩ) | Temperature (°C) | Resistance min(kΩ) | Resistance Normal(kΩ) | Resistance max(kΩ) |
|------------------|--------------------|-----------------------|--------------------|------------------|--------------------|-----------------------|--------------------|
| 40 | 4.926 | 5.179 | 5.441 | 80 | 1.060 | 1.166 | 1.281 |
| 41 | 4.718 | 4.968 | 5.225 | 81 | 1.025 | 1.128 | 1.240 |
| 42 | 4.521 | 4.766 | 5.019 | 82 | 0.990 | 1.091 | 1.201 |
| 43 | 4.333 | 4.573 | 4.822 | 83 | 0.958 | 1.056 | 1.164 |
| 44 | 4.154 | 4.390 | 4.634 | 84 | 0.926 | 1.022 | 1.127 |
| 45 | 3.983 | 4.215 | 4.455 | 85 | 0.895 | 0.990 | 1.092 |
| 46 | 3.821 | 4.047 | 4.283 | 86 | 0.866 | 0.958 | 1.059 |
| 47 | 3.666 | 3.888 | 4.120 | 87 | 0.838 | 0.928 | 1.026 |
| 48 | 3.518 | 3.736 | 3.963 | 88 | 0.811 | 0.899 | 0.995 |
| 49 | 3.377 | 3.590 | 3.813 | 89 | 0.785 | 0.870 | 0.965 |
| 50 | 3.243 | 3.451 | 3.670 | 90 | 0.760 | 0.843 | 0.935 |
| 51 | 3.114 | 3.318 | 3.533 | 91 | 0.735 | 0.817 | 0.907 |
| 52 | 2.991 | 3.192 | 3.402 | 92 | 0.712 | 0.792 | 0.880 |
| 53 | 2.874 | 3.070 | 3.276 | 93 | 0.689 | 0.768 | 0.854 |
| 54 | 2.762 | 2.954 | 3.156 | 94 | 0.668 | 0.744 | 0.829 |
| 55 | 2.656 | 2.843 | 3.041 | 95 | 0.647 | 0.722 | 0.804 |
| 56 | 2.553 | 2.737 | 2.931 | 96 | 0.627 | 0.700 | 0.781 |
| 57 | 2.456 | 2.635 | 2.825 | 97 | 0.607 | 0.679 | 0.758 |
| 58 | 2.362 | 2.538 | 2.723 | 98 | 0.589 | 0.659 | 0.736 |
| 59 | 2.273 | 2.444 | 2.626 | 99 | 0.571 | 0.639 | 0.715 |
| 60 | 2.187 | 2.355 | 2.533 | 100 | 0.553 | 0.620 | 0.694 |
| 61 | 2.105 | 2.269 | 2.444 | 101 | 0.537 | 0.602 | 0.674 |
| 62 | 2.027 | 2.187 | 2.358 | 102 | 0.520 | 0.584 | 0.655 |
| 63 | 1.952 | 2.109 | 2.276 | 103 | 0.505 | 0.567 | 0.637 |
| 64 | 1.880 | 2.033 | 2.197 | 104 | 0.490 | 0.551 | 0.619 |
| 65 | 1.811 | 1.961 | 2.121 | 105 | 0.475 | 0.535 | 0.602 |
| 66 | 1.745 | 1.892 | 2.048 | 106 | 0.461 | 0.520 | 0.585 |
| 67 | 1.682 | 1.825 | 1.978 | 107 | 0.448 | 0.505 | 0.569 |
| 68 | 1.622 | 1.761 | 1.911 | 108 | 0.434 | 0.490 | 0.553 |
| 69 | 1.564 | 1.700 | 1.847 | 109 | 0.422 | 0.477 | 0.538 |
| 70 | 1.508 | 1.641 | 1.785 | 110 | 0.410 | 0.463 | 0.523 |
| 71 | 1.455 | 1.585 | 1.725 | 111 | 0.398 | 0.450 | 0.509 |
| 72 | 1.403 | 1.530 | 1.668 | 112 | 0.386 | 0.438 | 0.495 |
| 73 | 1.354 | 1.478 | 1.613 | 113 | 0.375 | 0.425 | 0.482 |
| 74 | 1.307 | 1.428 | 1.559 | 114 | 0.365 | 0.414 | 0.469 |
| 75 | 1.261 | 1.380 | 1.509 | 115 | 0.354 | 0.402 | 0.456 |
| 76 | 1.218 | 1.334 | 1.460 | 116 | 0.344 | 0.391 | 0.444 |
| 77 | 1.176 | 1.289 | 1.412 | 117 | 0.335 | 0.381 | 0.433 |
| 78 | 1.136 | 1.247 | 1.367 | 118 | 0.325 | 0.370 | 0.421 |
| 79 | 1.098 | 1.206 | 1.323 | 119 | 0.317 | 0.361 | 0.410 |

3.2 Ambient Temperature and Standard Saturation Pressure of R410A

Table 9.2: Ambient Temperature and Standard Saturation Pressure of R410A (saturated vapor state)

| Ambient Temperature (°C) | Saturated gauge pressure (kPa) | Saturated gauge pressure (psi) | Ambient Temperature (°C) | Saturated gauge pressure (kPa) | Saturated gauge pressure (psi) | Ambient Temperature (°C) | Saturated gauge pressure (kPa) | Saturated gauge pressure (psi) |
|--------------------------|--------------------------------|--------------------------------|--------------------------|--------------------------------|--------------------------------|--------------------------|--------------------------------|--------------------------------|
| -70 | -65.879 | -9.5549 | -30 | 168.02 | 24.37 | 10 | 983.49 | 142.64 |
| -69 | -63.608 | -9.2256 | -29 | 179.3 | 26.005 | 11 | 1015.9 | 147.35 |
| -68 | -61.22 | -8.8793 | -28 | 190.93 | 27.693 | 12 | 1049.1 | 152.15 |
| -67 | -58.711 | -8.5154 | -27 | 202.94 | 29.434 | 13 | 1083 | 157.07 |
| -66 | -56.077 | -8.1332 | -26 | 215.32 | 31.23 | 14 | 1117.6 | 162.09 |
| -65 | -53.312 | -7.7322 | -25 | 228.09 | 33.081 | 15 | 1153 | 167.22 |
| -64 | -50.411 | -7.3115 | -24 | 241.25 | 34.99 | 16 | 1189.1 | 172.47 |
| -63 | -47.371 | -6.8706 | -23 | 254.81 | 36.957 | 17 | 1226 | 177.82 |
| -62 | -44.186 | -6.4087 | -22 | 268.78 | 38.983 | 18 | 1263.8 | 183.29 |
| -61 | -40.852 | -5.925 | -21 | 283.17 | 41.07 | 19 | 1302.3 | 188.88 |
| -60 | -37.362 | -5.4189 | -20 | 297.98 | 43.218 | 20 | 1341.6 | 194.58 |
| -59 | -33.713 | -4.8896 | -19 | 313.23 | 45.43 | 21 | 1381.8 | 200.41 |
| -58 | -29.898 | -4.3363 | -18 | 328.91 | 47.705 | 22 | 1422.7 | 206.35 |
| -57 | -25.913 | -3.7583 | -17 | 345.05 | 50.046 | 23 | 1464.6 | 212.42 |
| -56 | -21.752 | -3.1548 | -16 | 361.65 | 52.453 | 24 | 1507.3 | 218.61 |
| -55 | -17.409 | -2.525 | -15 | 378.71 | 54.928 | 25 | 1550.8 | 224.93 |
| -54 | -12.88 | -1.868 | -14 | 396.26 | 57.472 | 26 | 1595.3 | 231.37 |
| -53 | -8.1571 | -1.1831 | -13 | 414.28 | 60.086 | 27 | 1640.6 | 237.95 |
| -52 | -3.2361 | -0.46936 | -12 | 432.8 | 62.772 | 28 | 1686.8 | 244.65 |
| -51 | 1.8893 | 0.27402 | -11 | 451.82 | 65.531 | 29 | 1734 | 251.49 |
| -50 | 7.2252 | 1.0479 | -10 | 471.35 | 68.364 | 30 | 1782.1 | 258.47 |
| -49 | 12.777 | 1.8532 | -9 | 491.4 | 71.272 | 31 | 1831.1 | 265.58 |
| -48 | 18.552 | 2.6908 | -8 | 511.98 | 74.257 | 32 | 1881.1 | 272.83 |
| -47 | 24.556 | 3.5615 | -7 | 533.1 | 77.32 | 33 | 1932.1 | 280.23 |
| -46 | 30.794 | 4.4663 | -6 | 554.76 | 80.462 | 34 | 1984 | 287.76 |
| -45 | 37.274 | 5.4062 | -5 | 576.99 | 83.685 | 35 | 2037 | 295.44 |
| -44 | 44.002 | 6.382 | -4 | 599.77 | 86.99 | 36 | 2091 | 303.27 |
| -43 | 50.985 | 7.3947 | -3 | 623.13 | 90.378 | 37 | 2146 | 311.25 |
| -42 | 58.228 | 8.4453 | -2 | 647.08 | 93.851 | 38 | 2202 | 319.37 |
| -41 | 65.739 | 9.5347 | -1 | 671.62 | 97.41 | 39 | 2259.1 | 327.66 |
| -40 | 73.525 | 10.664 | 0 | 696.76 | 101.06 | 40 | 2317.3 | 336.09 |
| -39 | 81.592 | 11.834 | 1 | 722.51 | 104.79 | 41 | 2376.5 | 344.69 |
| -38 | 89.947 | 13.046 | 2 | 748.89 | 108.62 | 42 | 2436.9 | 353.44 |
| -37 | 98.598 | 14.3 | 3 | 775.9 | 112.53 | 43 | 2498.4 | 362.36 |
| -36 | 107.55 | 15.599 | 4 | 803.55 | 116.54 | 44 | 2561 | 371.45 |
| -35 | 116.81 | 16.942 | 5 | 831.85 | 120.65 | 45 | 2624.8 | 380.7 |
| -34 | 126.39 | 18.332 | 6 | 860.82 | 124.85 | 46 | 2689.8 | 390.12 |
| -33 | 136.3 | 19.768 | 7 | 890.45 | 129.15 | 47 | 2755.9 | 399.71 |
| -32 | 146.53 | 21.252 | 8 | 920.77 | 133.55 | 48 | 2823.3 | 409.48 |
| -31 | 157.1 | 22.786 | 9 | 951.78 | 138.04 | 49 | 2891.8 | 419.43 |

Table 9.2: Ambient Temperature and Standard Saturation Pressure of R410A (saturated vapor state)-continue

| | | | | | | | | |
|----|--------|--------|----|--------|--------|----|--------|--------|
| 50 | 2961.7 | 429.55 | 57 | 3487.2 | 505.78 | 64 | 4083.4 | 592.25 |
| 51 | 3032.8 | 439.87 | 58 | 3567.8 | 517.47 | 65 | 4175 | 605.54 |
| 52 | 3105.2 | 450.36 | 59 | 3649.9 | 529.38 | 66 | 4268.3 | 619.07 |
| 53 | 3178.9 | 461.05 | 60 | 3733.5 | 541.5 | 67 | 4363.5 | 632.87 |
| 54 | 3253.9 | 471.94 | 61 | 3818.6 | 553.84 | 68 | 4460.5 | 646.93 |
| 55 | 3330.3 | 483.02 | 62 | 3905.3 | 566.41 | 69 | 4559.4 | 661.28 |
| 56 | 3408 | 494.3 | 63 | 3993.5 | 579.21 | 70 | 4660.4 | 675.93 |

Table 9.3: Ambient Temperature and Standard Saturation Pressure of R410A (Saturated liquid state)

| Ambient Temperature (°C) | Saturated gauge pressure (kPa) | Saturated gauge pressure (psi) | Ambient Temperature (°C) | Saturated gauge pressure (kPa) | Saturated gauge pressure (psi) | Ambient Temperature (°C) | Saturated gauge pressure (kPa) | Saturated gauge pressure (psi) |
|--------------------------|--------------------------------|--------------------------------|--------------------------|--------------------------------|--------------------------------|--------------------------|--------------------------------|--------------------------------|
| -70 | -65.704 | -9.5296 | -37 | 99.329 | 14.407 | -4 | 602.1 | 87.327 |
| -69 | -63.425 | -9.1991 | -36 | 108.31 | 15.709 | -3 | 625.53 | 90.725 |
| -68 | -61.029 | -8.8515 | -35 | 117.6 | 17.057 | -2 | 649.55 | 94.209 |
| -67 | -58.511 | -8.4863 | -34 | 127.22 | 18.451 | -1 | 674.16 | 97.779 |
| -66 | -55.867 | -8.1028 | -33 | 137.15 | 19.892 | 0 | 699.38 | 101.44 |
| -65 | -53.092 | -7.7004 | -32 | 147.42 | 21.381 | 1 | 725.21 | 105.18 |
| -64 | -50.182 | -7.2782 | -31 | 158.03 | 22.92 | 2 | 751.67 | 109.02 |
| -63 | -47.131 | -6.8358 | -30 | 168.98 | 24.509 | 3 | 778.76 | 112.95 |
| -62 | -43.935 | -6.3722 | -29 | 180.29 | 26.15 | 4 | 806.49 | 116.97 |
| -61 | -40.589 | -5.8869 | -28 | 191.97 | 27.843 | 5 | 834.88 | 121.09 |
| -60 | -37.087 | -5.379 | -27 | 204.01 | 29.59 | 6 | 863.93 | 125.3 |
| -59 | -33.425 | -4.8479 | -26 | 216.44 | 31.391 | 7 | 893.66 | 129.61 |
| -58 | -29.597 | -4.2927 | -25 | 229.24 | 33.249 | 8 | 924.07 | 134.02 |
| -57 | -25.599 | -3.7128 | -24 | 242.45 | 35.164 | 9 | 955.17 | 138.54 |
| -56 | -21.423 | -3.1072 | -23 | 256.05 | 37.137 | 10 | 986.98 | 143.15 |
| -55 | -17.066 | -2.4752 | -22 | 270.07 | 39.17 | 11 | 1019.5 | 147.87 |
| -54 | -12.521 | -1.816 | -21 | 284.5 | 41.263 | 12 | 1052.7 | 152.69 |
| -53 | -7.7823 | -1.1287 | -20 | 299.36 | 43.419 | 13 | 1086.7 | 157.62 |
| -52 | -2.8446 | -0.41258 | -19 | 314.66 | 45.637 | 14 | 1121.5 | 162.65 |
| -51 | 2.2981 | 0.33331 | -18 | 330.39 | 47.92 | 15 | 1156.9 | 167.8 |
| -50 | 7.6519 | 1.1098 | -17 | 346.58 | 50.268 | 16 | 1193.2 | 173.06 |
| -49 | 13.223 | 1.9178 | -16 | 363.23 | 52.683 | 17 | 1230.2 | 178.43 |
| -48 | 19.017 | 2.7582 | -15 | 380.35 | 55.165 | 18 | 1268.1 | 183.92 |
| -47 | 25.041 | 3.6319 | -14 | 397.95 | 57.717 | 19 | 1306.7 | 189.52 |
| -46 | 31.3 | 4.5397 | -13 | 416.03 | 60.34 | 20 | 1346.1 | 195.24 |
| -45 | 37.802 | 5.4827 | -12 | 434.61 | 63.034 | 21 | 1386.4 | 201.08 |
| -44 | 44.553 | 6.4618 | -11 | 453.69 | 65.802 | 22 | 1427.5 | 207.04 |
| -43 | 51.558 | 7.4779 | -10 | 473.28 | 68.643 | 23 | 1469.4 | 213.12 |
| -42 | 58.826 | 8.5319 | -9 | 493.39 | 71.561 | 24 | 1512.2 | 219.33 |
| -41 | 66.362 | 9.625 | -8 | 514.04 | 74.555 | 25 | 1555.9 | 225.67 |
| -40 | 74.173 | 10.758 | -7 | 535.22 | 77.627 | 26 | 1600.5 | 232.13 |
| -39 | 82.267 | 11.932 | -6 | 556.95 | 80.779 | 27 | 1645.9 | 238.72 |
| -38 | 90.65 | 13.148 | -5 | 579.24 | 84.012 | 28 | 1692.3 | 245.45 |

Quantum Series (AU)



Table 9.3: Ambient Temperature and Standard Saturation Pressure of R410A (Saturated liquid state) -continue

| | | | | | | | | |
|----|--------|--------|----|--------|--------|----|--------|--------|
| 29 | 1739.6 | 252.31 | 43 | 2505.8 | 363.44 | 57 | 3495.4 | 506.96 |
| 30 | 1787.8 | 259.3 | 44 | 2568.5 | 372.54 | 58 | 3575.9 | 518.64 |
| 31 | 1837 | 266.43 | 45 | 2632.4 | 381.8 | 59 | 3657.9 | 530.53 |
| 32 | 1887.1 | 273.7 | 46 | 2697.5 | 391.24 | 60 | 3741.3 | 542.63 |
| 33 | 1938.2 | 281.11 | 47 | 2763.7 | 400.85 | 61 | 3826.2 | 554.95 |
| 34 | 1990.3 | 288.67 | 48 | 2831.2 | 410.63 | 62 | 3912.7 | 567.48 |
| 35 | 2043.4 | 296.37 | 49 | 2899.8 | 420.59 | 63 | 4000.6 | 580.24 |
| 36 | 2097.5 | 304.22 | 50 | 2969.7 | 430.73 | 64 | 4090.2 | 593.23 |
| 37 | 2152.6 | 312.21 | 51 | 3040.9 | 441.05 | 65 | 4181.3 | 606.45 |
| 38 | 2208.8 | 320.36 | 52 | 3113.3 | 451.55 | 66 | 4274.1 | 619.9 |
| 39 | 2266 | 328.66 | 53 | 3187.1 | 462.25 | 67 | 4368.6 | 633.61 |
| 40 | 2324.3 | 337.11 | 54 | 3262.1 | 473.13 | 68 | 4464.8 | 647.56 |
| 41 | 2383.7 | 345.73 | 55 | 3338.5 | 484.21 | 69 | 4562.8 | 661.77 |
| 42 | 2444.2 | 354.5 | 56 | 3416.3 | 495.49 | 70 | 4662.6 | 676.25 |

3.3 Ambient Temperature and Standard Saturation Pressure of R32
Table 9.4: Ambient Temperature and Standard Saturation Pressure of R32

| Ambient Temperature (°C) | Saturated gauge pressure (kPa) | Saturated gauge pressure (psi) | Ambient Temperature (°C) | Saturated gauge pressure (kPa) | Saturated gauge pressure (psi) | Ambient Temperature (°C) | Saturated gauge pressure (kPa) | Saturated gauge pressure (psi) |
|--------------------------|--------------------------------|--------------------------------|--------------------------|--------------------------------|--------------------------------|--------------------------|--------------------------------|--------------------------------|
| -70 | -65.258 | -9.4649 | -29 | 183.58 | 26.627 | 12 | 1072.9 | 155.6 |
| -69 | -62.958 | -9.1312 | -28 | 195.42 | 28.344 | 13 | 1107.6 | 160.65 |
| -68 | -60.539 | -8.7804 | -27 | 207.64 | 30.115 | 14 | 1143.2 | 165.8 |
| -67 | -57.997 | -8.4118 | -26 | 220.24 | 31.943 | 15 | 1179.5 | 171.07 |
| -66 | -55.328 | -8.0247 | -25 | 233.24 | 33.828 | 16 | 1216.6 | 176.45 |
| -65 | -52.527 | -7.6184 | -24 | 246.64 | 35.772 | 17 | 1254.5 | 181.95 |
| -64 | -49.589 | -7.1923 | -23 | 260.45 | 37.775 | 18 | 1293.3 | 187.57 |
| -63 | -46.509 | -6.7456 | -22 | 274.68 | 39.838 | 19 | 1332.8 | 193.31 |
| -62 | -43.283 | -6.2777 | -21 | 289.33 | 41.964 | 20 | 1373.2 | 199.17 |
| -61 | -39.905 | -5.7877 | -20 | 304.43 | 44.153 | 21 | 1414.5 | 205.16 |
| -60 | -36.37 | -5.275 | -19 | 319.97 | 46.407 | 22 | 1456.6 | 211.27 |
| -59 | -32.673 | -4.7388 | -18 | 335.96 | 48.727 | 23 | 1499.6 | 217.5 |
| -58 | -28.808 | -4.1782 | -17 | 352.42 | 51.114 | 24 | 1543.5 | 223.87 |
| -57 | -24.77 | -3.5926 | -16 | 369.34 | 53.569 | 25 | 1588.3 | 230.36 |
| -56 | -20.553 | -2.981 | -15 | 386.75 | 56.093 | 26 | 1634 | 236.99 |
| -55 | -16.153 | -2.3428 | -14 | 404.65 | 58.689 | 27 | 1680.6 | 243.75 |
| -54 | -11.562 | -1.677 | -13 | 423.04 | 61.357 | 28 | 1728.2 | 250.65 |
| -53 | -6.7758 | -0.98275 | -12 | 441.94 | 64.098 | 29 | 1776.7 | 257.69 |
| -52 | -1.7877 | -0.25928 | -11 | 461.36 | 66.915 | 30 | 1826.2 | 264.87 |
| -51 | 3.4082 | 0.49432 | -10 | 481.31 | 69.808 | 31 | 1876.6 | 272.18 |
| -50 | 8.8179 | 1.2789 | -9 | 501.79 | 72.778 | 32 | 1928.1 | 279.65 |
| -49 | 14.448 | 2.0955 | -8 | 522.81 | 75.828 | 33 | 1980.5 | 287.25 |
| -48 | 20.304 | 2.9448 | -7 | 544.39 | 78.957 | 34 | 2034 | 295.01 |
| -47 | 26.393 | 3.8279 | -6 | 566.53 | 82.169 | 35 | 2088.5 | 302.91 |
| -46 | 32.721 | 4.7457 | -5 | 589.25 | 85.464 | 36 | 2144.1 | 310.97 |
| -45 | 39.295 | 5.6992 | -4 | 612.55 | 88.843 | 37 | 2200.7 | 319.18 |
| -44 | 46.121 | 6.6893 | -3 | 636.44 | 92.308 | 38 | 2258.3 | 327.55 |
| -43 | 53.206 | 7.7169 | -2 | 660.94 | 95.861 | 39 | 2317.1 | 336.07 |
| -42 | 60.558 | 8.7831 | -1 | 686.05 | 99.503 | 40 | 2377 | 344.75 |
| -41 | 68.182 | 9.8889 | 0 | 711.78 | 103.23 | 41 | 2438 | 353.6 |
| -40 | 76.086 | 11.035 | 1 | 738.14 | 107.06 | 42 | 2500.1 | 362.61 |
| -39 | 84.277 | 12.223 | 2 | 765.15 | 110.97 | 43 | 2563.4 | 371.79 |
| -38 | 92.762 | 13.454 | 3 | 792.8 | 114.99 | 44 | 2627.8 | 381.13 |
| -37 | 101.55 | 14.728 | 4 | 821.13 | 119.09 | 45 | 2693.5 | 390.65 |
| -36 | 110.64 | 16.048 | 5 | 850.12 | 123.3 | 46 | 2760.3 | 400.34 |
| -35 | 120.05 | 17.413 | 6 | 879.8 | 127.6 | 47 | 2828.3 | 410.21 |
| -34 | 129.79 | 18.824 | 7 | 910.18 | 132.01 | 48 | 2897.6 | 420.26 |
| -33 | 139.86 | 20.284 | 8 | 941.26 | 136.52 | 49 | 2968.1 | 430.49 |
| -32 | 150.26 | 21.793 | 9 | 973.06 | 141.13 | 50 | 3039.9 | 440.9 |
| -31 | 161.01 | 23.353 | 10 | 1005.6 | 145.85 | 51 | 3113 | 451.5 |
| -30 | 172.12 | 24.963 | 11 | 1038.8 | 150.67 | 52 | 3187.4 | 462.29 |

Quantum Series (AU)



Table 9.4: Ambient Temperature and Standard Saturation Pressure of R32 (continue)

| | | | | | | | | |
|----|--------|--------|----|--------|--------|----|--------|--------|
| 53 | 3263.1 | 473.27 | 59 | 3746.3 | 543.36 | 65 | 4282.9 | 621.19 |
| 54 | 3340.1 | 484.45 | 60 | 3831.9 | 555.77 | 66 | 4378 | 634.97 |
| 55 | 3418.6 | 495.82 | 61 | 3919 | 568.4 | 67 | 4474.7 | 649 |
| 56 | 3498.4 | 507.39 | 62 | 4007.6 | 581.25 | 68 | 4573.2 | 663.29 |
| 57 | 3579.6 | 519.17 | 63 | 4097.8 | 594.33 | 69 | 4673.4 | 677.82 |
| 58 | 3662.2 | 531.16 | 64 | 4189.6 | 607.64 | 70 | 4775.5 | 692.63 |

3.4 Sensor codes and definitions applicable to the table
Table 9.5: Sensor codes and definitions

| Sensor code | definition | Sensor code | definition |
|-------------|-----------------------------|-------------|--------------------------|
| T1 | Inlet Air Temp. Sensor | T2A | Liquid Pipe Temp. Sensor |
| T0 | Outdoor Air Temp. Sensor* | T2 | Middle Pipe Temp. Sensor |
| TA | Discharge Air Temp. Sensor* | T2B | Gas Pipe Temp. Sensor |

* Indicates that this sensor is only available for Fresh Air Processing Unit

Midea Building Technologies Division
Midea Group

Add.: Midea Headquarters Building, 6 Midea Avenue, Shunde, Foshan, Guangdong, China

Postal code: 528311

mbt.midea.com/global / www.midea-group.com / ics.midea.com

Note: Product specifications change from time to time as product improvements and developments are released and may vary from those in this document.

