



# Freezer

## use & care

Introduction.....	2	Controls and Settings.....	19
Important Safety information.....	3	Ice Maker .....	23
Features.....	6	Storage Features.....	24
Installation .....	8	Saving Energy .....	27
Door Reversal .....	12	Filter Replacement .....	28
Door Removal.....	13	Care and Cleaning .....	29
Door Handle Installation.....	15	Troubleshooting .....	31
Water Supply Connection.....	16	Limited Warranty .....	34

# 2

## INTRODUCTION

Welcome to our **family**

Thank you for bringing Frigidaire into your home! We see your purchase as the beginning of a long relationship together.

This manual is your resource for the use and care of your product. Please read it before using your appliance. Keep it handy for quick reference. If something doesn't seem right, the troubleshooting section will help you with common issues.

FAQs, helpful tips and videos, cleaning products, and kitchen and home accessories are available at Frigidaire.com.

We are here for you! Visit our website, chat with an agent, or call us if you need help. We may be able to help you avoid a service visit. If you do need service, we can get that started for you.

Let's make it official! Be sure to register your product.

Keep your product info here so it's easy to find.

Model Number \_\_\_\_\_

Serial Number \_\_\_\_\_

Purchase Date \_\_\_\_\_

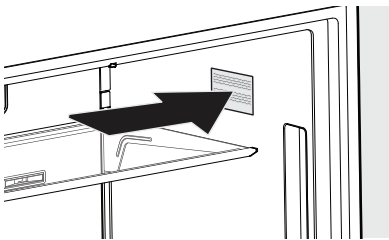

Serial Number Location



### Installation Checklist

#### Doors

- Handles are secure and tight
- Door seals completely to cabinet on all sides
- Door is level from side to side across the top

#### Leveling

- Appliance is level, side to side and front to back
- Cabinet is setting solid on all corners
- Anti-tip bracket is set in front

#### Electrical Power

- House power is turned on
- Appliance is plugged in

#### Ice Maker

- House water supply is connected to the appliance (**Warning:** Potable water supply only.)
- No water leaks present at all connections - recheck in 24 hours
- Ice maker is turned on

#### Final Checks

- Shipping material is removed
- Registration card is sent in
- Appliance temperatures are set to recommended settings
- Provided accessories and consumables are installed



## WARNING

Please read all instructions before using this appliance.

## Safety Definitions

 This is the safety alert symbol. It is used to alert of potential personal injury hazards. Obey all safety messages that follow this symbol to avoid possible injury or death.



## DANGER

DANGER indicates an imminently hazardous situation which, if not avoided, will result in death or serious injury.



## WARNING

WARNING indicates a potentially hazardous situation which, if not avoided, could result in death or serious injury.



## CAUTION

CAUTION indicates a potentially hazardous situation which, if not avoided, may result in minor or moderate injury.



## IMPORTANT

IMPORTANT indicates installation, operation or maintenance information which is important but not hazard-related.



## WARNING

When positioning the appliance, ensure the supply cord is not trapped or damaged.



## WARNING

Do not locate multiple portable socket-outlets or portable power supplies at the rear of the appliance



## DANGER



DANGER Risk of fire or explosion. Flammable refrigerant used. Do not use mechanical devices to defrost refrigerator. Do not puncture refrigerant tubing.

DANGER Risk of fire or explosion. Flammable refrigerant used. To be repaired only by trained service personnel. Use only manufacturer-authorized service parts. Any repair equipment used must be designed for flammable refrigerants. Follow all manufacturer repair instructions. Do not puncture refrigerant tubing.



## CAUTION



CAUTION Risk of fire or explosion. Dispose of refrigerator properly in accordance with the applicable federal or local regulations. Flammable refrigerant used.

CAUTION Risk of fire or explosion due to puncture of refrigerant tubing. Follow handling instructions carefully. Flammable refrigerant used.



## WARNING

**CALIFORNIA RESIDENTS ONLY**  
**Cancer and Reproductive Harm**  
[www.P65Warnings.ca.gov](http://www.P65Warnings.ca.gov)

# 4

## IMPORTANT SAFETY INFORMATION

---

### Child Safety

This appliance is not intended for use by persons (including children) with reduced physical, sensory or mental capabilities, or lack of experience and knowledge, unless they have been given supervision or instruction concerning use of the appliance by a person responsible for their safety.

Destroy or recycle the carton, plastic bags, and any exterior wrapping material immediately after you unpack the refrigerator. Children should **NEVER** use these items to play. Cartons covered with rugs, bedspreads, plastic sheets or stretch wrap may become airtight chambers, and can quickly cause suffocation.

### Safety Instructions

- DO NOT store or use gasoline, or other flammable liquid within or in the vicinity of this appliance. Read Product Label for warnings regarding flammability and other hazards.
- DO NOT store explosive substances such as aerosol cans with a flammable propellant in this appliance.
- DO NOT operate the refrigerator in the presence of explosive fumes.
- Avoid contact with any moving parts of automatic ice maker.
- Remove all staples from the carton. Staples can cause severe cuts, and also destroy finishes if they come in contact with other appliances or furniture.



### WARNING

Do not use electrical appliances inside the food storage compartments of the appliance unless they are of the type recommended by the manufacturer.

### Proper Disposal of your Appliance

#### Risk of child entrapment

Child entrapment and suffocation are not problems of the past. Junked or abandoned appliances are still dangerous – even if they will sit for “just a few days”. If you are getting rid of your old appliance, please follow the instructions below to help prevent accidents.

We strongly encourage responsible appliance recycling/disposal methods. Check with your utility company or visit [energystar.gov/products/recycle](http://energystar.gov/products/recycle) for more information on recycling your old appliance.

#### Before you throw away your old appliance:

- Remove door.
- Leave shelves in place so children may not easily climb inside.
- Have refrigerant removed by a qualified service technician.

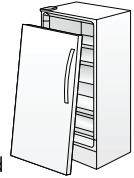



## WARNING

Follow these guidelines to ensure safety mechanisms in this appliance will operate properly.



## IMPORTANT

To turn off power to your appliance you must unplug the power cord from the electrical outlet.

## Electrical information

- Plug the appliance into its own dedicated 115-Volt, 60-Hz., 15-Amp, AC-only duplex electrical outlet. The power cord of the appliance is equipped with a 3-prong grounding plug for your protection against electrical shock hazards. Plug it directly into a properly grounded 3-prong receptacle. Install the receptacle in accordance with local codes and ordinances. Consult a qualified electrician. Do not use an extension cord or adapter plug.
- If the power cord is damaged, an authorized service technician should replace it to prevent any risk.
- Never unplug the appliance by pulling on the power cord. Always grip the plug firmly, and pull straight out from the receptacle to prevent damaging the power cord.
- Unplug the appliance before cleaning to avoid electrical shock.
- Performance may be affected if the voltage varies by 10% or more. Operating the appliance with insufficient power can damage the compressor. Such damage is not covered under your warranty.
- Do not plug the unit into an electrical outlet controlled by a wall switch or pull cord to prevent the appliance from being turned off accidentally.
- **WARNING:** Do not use electrical appliances inside the food storage compartments of the appliance unless they are recommended accessories for use within this model.

## Appliance Setup

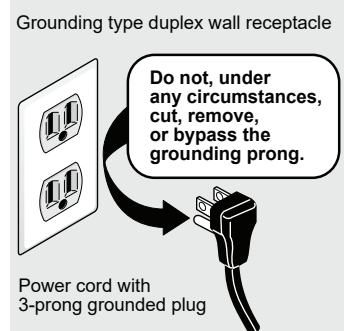

Use a dedicated grounding-type duplex electrical outlet for each unit (i.e. two duplex outlet receptacles, each on a dedicated electrical circuit) for a paired unit configuration.

# 6

## FEATURES

\*Features may vary according to model

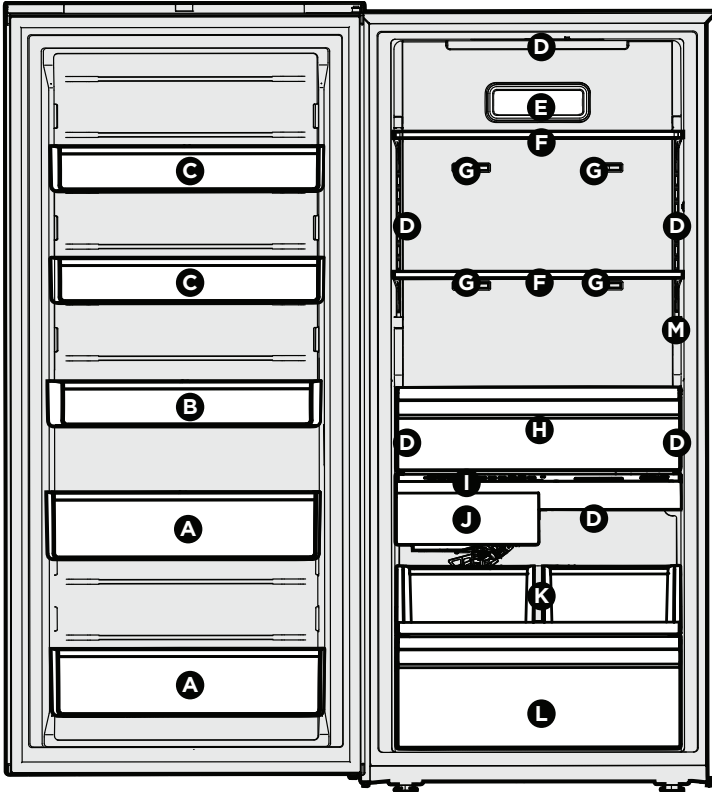

<b>A</b>	Adjustable Tall Item Door Bins with Dividers
<b>B</b>	Adjustable Gallon Door Bin with Divider
<b>C</b>	Adjustable Half-Gallon Door Bins with Dividers
<b>D</b>	LED Lighting
<b>E</b>	Air Filter
<b>F</b>	Adjustable Full Width Shelves

<b>G</b>	*Multi-Port Air Exhaust Ducts
<b>H</b>	Soft Freeze Zone Drawer
<b>I</b>	Appliance Control Display
<b>J</b>	Ice Maker
<b>K</b>	Slide-Out Shelf with Removable Ice Storage Bins
<b>L</b>	Lower Storage Drawer with Dividers
<b>M</b>	Temperature Sensor/Thermistor

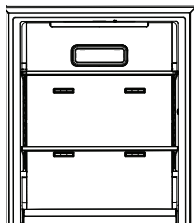

### IMPORTANT

\*Do not place items in front of the Multi-Port Air Exhaust Ducts or the Temperature Sensor as this will impact temperature performance.

**IMPORTANT****Cleaning your Appliance**

Remove tape and glue residue from surfaces before turning on the appliance. Rub a small amount of liquid dish soap over any remaining adhesive with your fingers. Rinse with warm water and dry with a soft cloth.

Do not use sharp instruments, rubbing alcohol, flammable fluids, or abrasive cleaners to remove tape or glue. These products can damage the surface of your appliance.

After you remove all of the package materials, clean the inside of your appliance before using it. See the **CARE & CLEANING** section in this manual.

See important information about cleaning glass shelves and covers in the **STORAGE FEATURES** section of this manual.

**IMPORTANT****Moving your Appliance**

Your appliance is heavy. When moving the appliance for cleaning or service, raise the anti-tip bracket (see **Setting the anti-tip bracket**). Be sure to cover the floor with cardboard or hardboard to avoid floor damage. Always pull the appliance straight out when moving it. Do not wiggle or “walk” the appliance when trying to move it as floor damage could occur.

**IMPORTANT**

Accessories are available for your appliance and may be purchased at [Frigidaire.com](http://Frigidaire.com) or by calling 1-800-374-4432 (Frigidaire.ca or 1-800-265-8352 in Canada) or from an authorized seller.

# 8

## INSTALLATION

This Use & Care Manual provides general operating instructions for your model. Use the appliance only as instructed in this Use & Care Manual. Before starting the appliance, follow these important first steps.

### Location

- Choose a place near a grounded electrical outlet. Do Not use an extension cord or an adapter plug.
- If possible, place the appliance out of direct sunlight and away from the range, dishwasher or other heat sources.
- Install the appliance on a floor level and strong enough to support a fully loaded appliance.



### WARNING

This appliance is intended for use in residential household and similar interior applications such as:

- Kitchen / Kitchenette
- Pantry Room
- Basement
- Enclosed Garage
- Other interior residential type environments



### WARNING

DO NOT install the appliance where the temperature will drop below 0°F (-18°C) or rise above 110°F (43°C). The compressor will not be able to maintain proper temperatures inside the unit.



### CAUTION

Do not block the lower front of your appliance. Sufficient air circulation is essential to operate your appliance properly.

### Installation



### WARNING

#### Installation clearances

Allow the following clearances for ease of installation, proper air circulation, and plumbing and electrical connections:

Sides	3/16"
Top & Back	1"

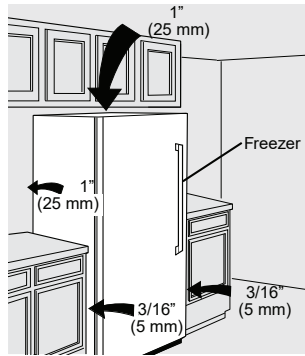

### NOTE

If you place your appliance with the door hinge side against a wall, you may have to allow additional space for the handle so you can open the door wider.

### Minimum Cabinet dimensions for Single Unit WITHOUT Trim Kit

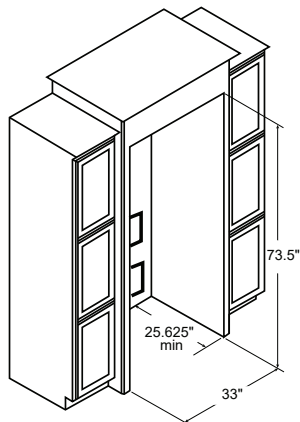

## Recommended Tools

- Level
- Appliance Slider



### CAUTION

This unit does not have rollers. Use an appliance slider or protective floor covering while moving the unit into place. Do not slide the unit with leveling legs fully extended.

## Leveling

Rest all bottom feet firmly on a solid floor.

It is **VERY IMPORTANT** for you to level your unit in order for it to function properly. If you do not level the appliance during installation, the door may be misaligned and not close or seal properly, causing cooling, frost or moisture problems.



### CAUTION

The cabinet is heavy. We recommend two people to level the cabinet.

## To Level the Appliance:

Insert the appliance slider under the unit. Place the unit into its location. Use the carpenter's level to make sure the unit is level from front to back and side to side. First adjust the front leveling legs, and then the rear if necessary. If you cannot access the rear leveling legs, slide the unit back out and adjust it. Slide the unit back into place and recheck with the level. Repeat if necessary.

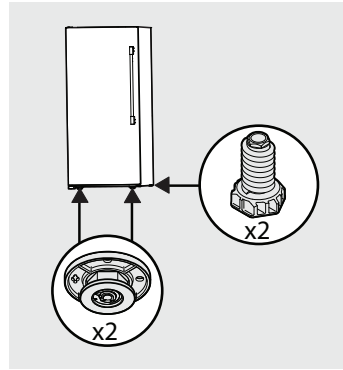

### IMPORTANT

Level the appliance to ensure optimal performance of the ice maker.

# 10 INSTALLATION

## Setting the anti-tip bracket:

Units are equipped with an anti-tip bracket. The anti-tip bracket is located on the lower front corner of the cabinet, on the lower hinge bracket. After fully leveling the unit, lower the anti-tip foot by turning it clockwise until it securely contacts the floor. Do not raise the cabinet.

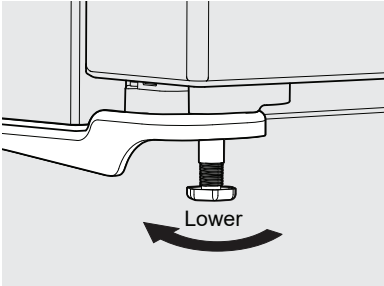

Anti-tip Bracket



## WARNING



Install the anti-tip device according to the instructions in your Use & Care Manual. Failure to do so may result in injury.

## Lower Hinge Adjustment for Leveling the Doors of the Matching Refrigerator / Freezer Pair

To level the doors using the adjustable lower hinge (some models):

If the refrigerator door is lower than the freezer door, raise the refrigerator door by turning the adjustment screw counter-clockwise using a 19 mm socket wrench. (See illustration below.)

If the freezer door is lower than the refrigerator door, raise the freezer door by turning the adjustment screw counter-clockwise using a 19 mm socket wrench. (See illustration below.)

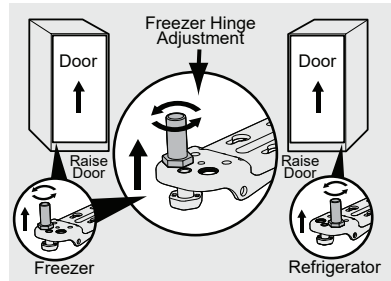

## Guidelines for final positioning of your appliance:

- Rest all bottom leveling feet firmly on a solid floor.
- Level the cabinet on all sides.
- Level the door.

## Pairing Installation

Pairing kit (TWINSPAIRKIT) is **REQUIRED** if you are installing the following appliances next to each other:

- Freezer and Refrigerator
- Freezer and Freezer
- Refrigerator and Refrigerator

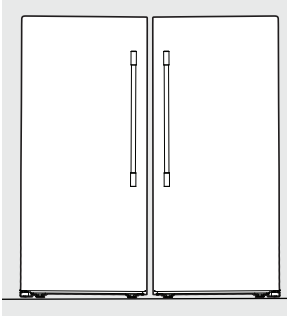

To obtain this kit, please contact the retailer where you purchased your appliances, or contact Frigidaire customer service at 1-800-374-4432 in the US, 1-800-265-8352 in Canada.

## Filtered Ice Kit

In order for the freezer ice maker to have filtered water for ice, we recommend filtered ice kit (TTICEKITSVC) when you are installing the following appliances next to each other:

- Freezer and Refrigerator

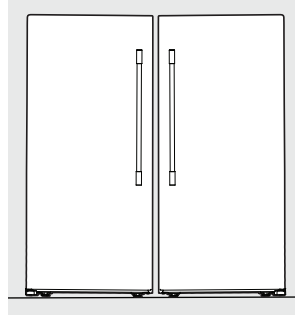

To obtain this kit, please contact the retailer where you purchased your appliances, or contact Frigidaire customer service at 1-800-374-4432 in the US, 1-800-265-8352 in Canada.

# 12

## DOOR REVERSAL

---

### Single Unit Door Swing Reversal:

- **TTDRRVFRKIT2 Frig Pro TT Refrigerator** - Right-hand to Left-hand Swing
- **TTDRRVFKIT2 Frig Pro TT Freezer** - Left-hand to Right-hand Swing

### For Model with Gray interior walls:

- **TTDRRVGRKIT2 Frig Pro TT Grey Liner Refrigerator** - Right-hand to Left-hand Swing
- **TTDRRVGFKIT2 Frig Pro TT Grey Liner Freezer** - Left-hand to Right-hand Swing

Order the kit on [Frigidaire.com](http://Frigidaire.com) or by calling 1-800-374-4432 ([Frigidaire.ca](http://Frigidaire.ca) or 1-800-265-8352 in Canada).

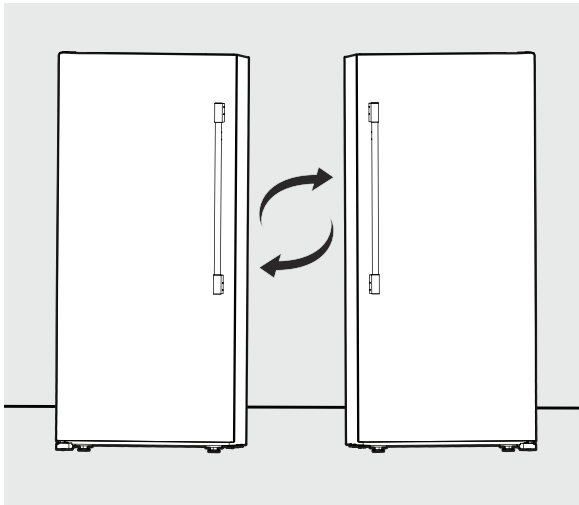

Left-hand Swing

Right-hand Swing

### Dual Unit Door Reversal:

- Moving the Freezer door to the Refrigerator also changes the right-hand swing to a left-hand swing.
- Moving the Refrigerator door to the Freezer also changes the left-hand swing to a right-hand swing.



#### NOTE

Transfer the hinges and associated hardware in order to switch doors.



#### CAUTION

Doors are heavy. We recommend two people to remove or replace the door assembly from the cabinet.

---

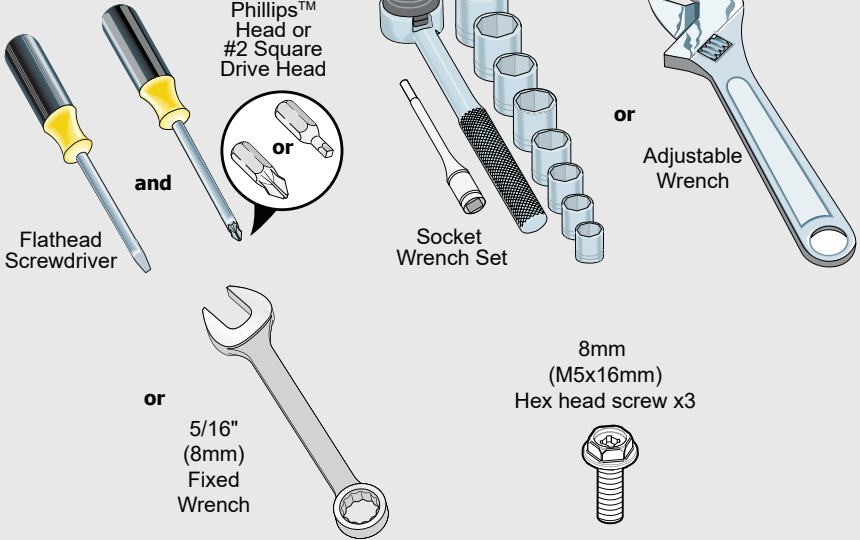
**Tools Necessary:****Door removal:****IMPORTANT**

Before you begin, remove the electrical power cord from the wall outlet. Remove any food from door shelves.

**CAUTION**

Doors are heavy. We recommend two people to remove or replace the door assembly from the cabinet.

**CAUTION**

Close the door prior to removing or installing.

- Unplug the unit or switch the breaker supplying power to the unit to the off position.
- Hold the door in place while removing the top hinge from the cabinet.
- Remove the M5x16 mm hex head screws from the top hinge with a wrench or socket.

- Lift the door up and pull up and away from the cabinet until free of the bottom hinge pin mounted on the front of the cabinet.
- To replace the door, reverse the above procedures and securely tighten all screws to prevent hinge slippage.

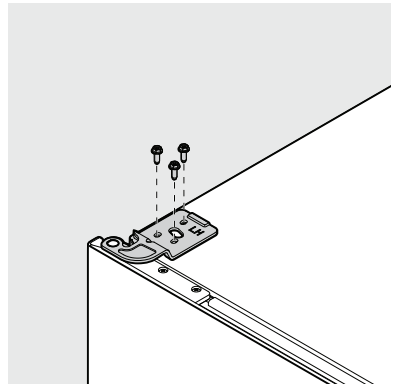

# 14 DOOR REMOVAL

---

If transporting your unit requires door removal, you must have a consistent 9 mm door gap around the perimeter of the cabinet to ensure proper gasket sealing to prevent frost in freezer. Measure the 9 mm gap from the metal of the cabinet to the metal on the door.

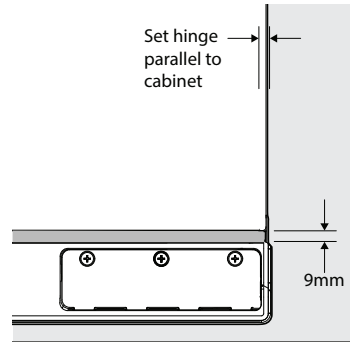

**CAUTION**

Wear gloves and use extreme CAUTION when installing these handles. The rounded end of the handles may be sharp.

**NOTE**

Tighten and sub-flush all set screws of the handle end cap (seat the Allen set screw just below the surface of the end cap). Draw the end caps tight to door with no gaps.

**Door Handle Mounting Instructions**

1. Remove the handle and any other protective packaging from the carton.
2. Position the handle end caps over the upper and lower pre-installed shoulder bolts (A) fastened into the door, ensuring the holes for the set screws are facing toward the hinge.
3. While holding the handle firmly against door, fasten the upper and lower Allen set screws (B) with the supplied Allen wrench.

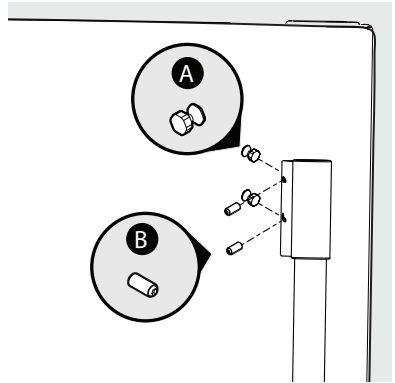

# 16

## WATER SUPPLY CONNECTION

---



### WARNING

To avoid electric shock, which can cause death or severe personal injury, disconnect the unit from the electrical power source before connecting a water supply line to the appliance.



### CAUTION

To Avoid Property Damage:

- Use Copper or Stainless Steel braided tubing for the water supply line. We do not recommend water supply tubing made of 1/4" plastic. Plastic tubing greatly increases the potential for water leaks, and the manufacturer will not be responsible for any damage if plastic tubing is used for the supply line.
- DO NOT install water supply tubing in areas where temperatures fall below freezing.
- Chemicals from a malfunctioning softener can damage the ice maker. If you connect the ice maker to soft water, ensure the softener is maintained and working properly.



### NOTE

Ensure your water supply line connections comply with all local plumbing codes.

### Before Installing The Water Supply Line, You Will Need:

- Basic Tools: adjustable wrench, flat-blade screwdriver, and Phillips™ screwdriver
- Access to a household cold water line with water pressure between 30 and 100 psi.
- A braided stainless steel water supply line with integral fittings such as Smart Choice® 5304437642 or 1/4" copper line with compression fittings. The line must be 6' or longer to allow you to move the appliance for cleaning.
- A shutoff valve to connect the water supply line to your household water system. DO NOT use a self-piercing type shutoff valve.
- Do not reuse compression fitting or use thread seal tape.
- A compression nut and ferrule (sleeve) for connecting a copper water supply line to the ice maker inlet valve.

## To Connect Water Supply Line To Ice Maker Inlet Valve

1. Disconnect the appliance from the electrical power source.
2. Place the end of the water supply line into a sink or bucket. Turn ON the water supply and flush the supply line until the water is clear. Turn OFF the water supply at the shutoff valve.
3. Remove the plastic cap from the water valve inlet and discard the cap.
4. If you use **copper tubing** - Slide the brass compression nut and then the ferrule (sleeve) onto the water supply line. Push the water supply line into the water valve inlet as far as it will go ( $\frac{1}{4}$ "/6,4 mm). Slide the ferrule (sleeve) into the valve inlet and finger tighten the compression nut onto the valve. Tighten another half turn with a wrench; DO NOT overtighten. See Figure 1.

If you use **braided flexible stainless steel tubing** - The nut is already assembled on the tubing. Slide the nut onto the valve inlet and finger tighten the nut onto the valve. Tighten another half turn with a wrench; DO NOT overtighten. See Figure 2.

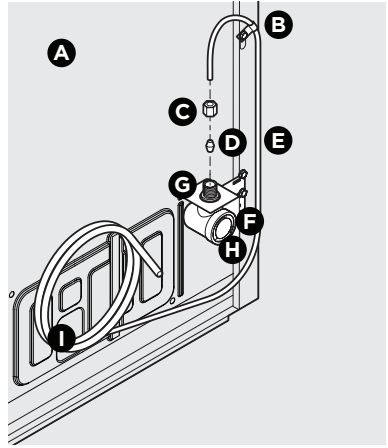

Figure 1

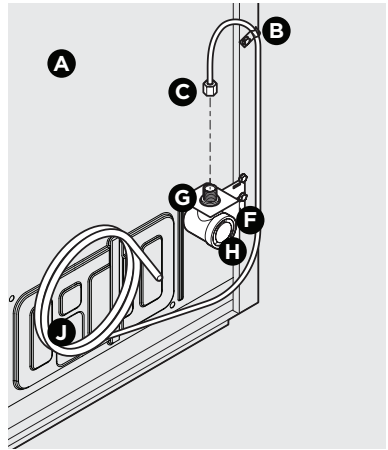

Figure 2

<b>A</b>	Plastic Water Tubing to Ice Maker Fill Tube (foamed within the cabinet)
<b>B</b>	Steel Clamp (Fig. 1: $\frac{1}{4}$ "; Fig. 2: $\frac{1}{2}$ " )
<b>C</b>	Brass Compression Nut
<b>D</b>	Ferrule (Sleeve)
<b>E</b>	Copper Water Line
<b>F</b>	Water Valve Bracket
<b>G</b>	Valve Inlet
<b>H</b>	Water Valve
<b>I</b>	Copper Water Line from Household Water Supply*
<b>J</b>	Braided Flexible Stainless Steel Water Line

\*Include enough tubing in the loop to allow moving the appliance out for cleaning

# 18

## WATER SUPPLY CONNECTION

---

5. With the steel clamp and screw, secure the water supply line (copper tubing only) to the rear panel of the appliance as shown.
6. Coil the excess water supply line (copper tubing only), about 2½ turns, behind appliance as shown and arrange coils so they do not vibrate or wear against any other surface.
7. Turn ON the water supply at the shutoff valve and tighten any connections that leak.
8. Reconnect the appliance to the electrical power source.
9. To turn the ice maker on, press and hold **ICE MAKER** on the appliance control display for 3 seconds.



### NOTE

Check with your local building authority for recommendations on water lines and associated materials prior to installing your new appliance. Depending on your local/state building codes, we recommend for homes with existing valves Smart Choice® water line kit 5305513409 (with a 6' Stainless Steel Water Line) and for homes without an existing valve, we recommend Smart Choice® water line kit 5305510264 (with a 20' copper water line with self-tapping saddle valve). Please refer to [Frigidaire.com](http://Frigidaire.com) for more information.

## Cool Down Period

To ensure safe food storage, allow the appliance to operate with the door closed for at least 8 hours before loading it with food.

## Power On

Upon opening the door, the settings icon illuminate on the appliance control display.



By pressing the settings icon, you illuminate all of the icons on the appliance control display. After 10 seconds of no user interaction with the icons or door closure, all the icons fade, except for the settings icon.

## Appliance Control Display

The appliance control display is located in the cabinet below the upper drawer.

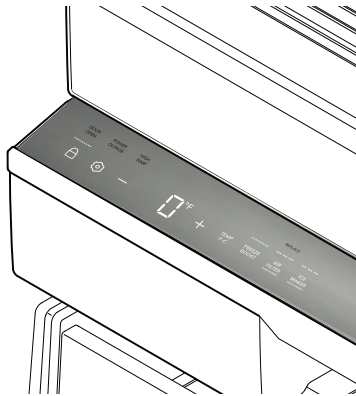

Features may vary by model.





# 20 CONTROLS AND SETTINGS

---

## Alarms

- 1 DOOR OPEN**  
This alert indicates you have had the door open for 5 minutes or more. **DOOR OPEN** illuminates and the audible alert sounds until you close the door.  
You can turn off the audible alert by pressing **DOOR OPEN** or by closing the door. If you leave the door ajar for 5 minutes, the interior light turns off.
- 2 POWER OUTAGE**  
**POWER OUTAGE** informs you of a power interruption which could have led to the internal temperature increasing beyond the safe temperature range. After you check your food, reset the alarm by pressing **POWER OUTAGE**.
- 3 HIGH TEMP**  
If the temperature increases above a safe temperature range, the red **HIGH TEMP** LED light illuminates and the alarm sounds. Reset the alarm by pressing **HIGH TEMP**.

## Controls

- 4** Use  to lock the appliance control display. Press and hold  for 3 seconds to enable/disable. While in the locked state, you cannot make changes until you unlock it.
  - 5** The settings icon illuminates upon opening the appliance door. Press  to reveal other function icons. After 10 seconds of not using icons or closing the door, all icons fade except .
  - 6 Adjusting Temp**  
To adjust the temperature setting, press **+** to raise the temperature and **-** to lower the temperature on the appliance control display. Allow several hours for the temperature to stabilize between adjustments.
  - 7 TEMP °F/°C**  
Short press to toggle between Fahrenheit (°F) and Celsius (°C).
  - 8 FREEZE BOOST**  
Prior to grocery shopping, activate **FREEZE BOOST** so upon returning you can ensure your newly purchased frozen food will be preserved.  
Turning on **FREEZE BOOST** cools the appliance down to a target temperature and remains active for up to 24 hours before automatically deactivating or being manually exited.  
To turn the function off, press **FREEZE BOOST**. When you turn off **FREEZE BOOST**, it automatically resets the freezer back to the previous temperature setting.
  - 9 AIR FILTER**  
The **AIR FILTER** replacement alert illuminates when it is time to replace the air filter. See the **FILTER REPLACEMENT** section for instructions on how to replace the air filter. After changing the air filter, reset the **AIR FILTER** alert by pressing and holding **AIR FILTER**.
  - 10 ICE MAKER**  
The ice maker is default on, which means it constantly makes ice until the ice bucket is full. You can turn off the ice maker to stop making new ice by pressing and holding **ICE MAKER** for 3 seconds.
-

## Sabbath Mode

The Sabbath Mode feature disables portions of the appliance and its controls in accordance with observance of the weekly Sabbath and religious holidays within the Orthodox Jewish community.

### To enter Sabbath Mode

Simultaneously press and hold **—** and **TEMP F/C** for 5 seconds.

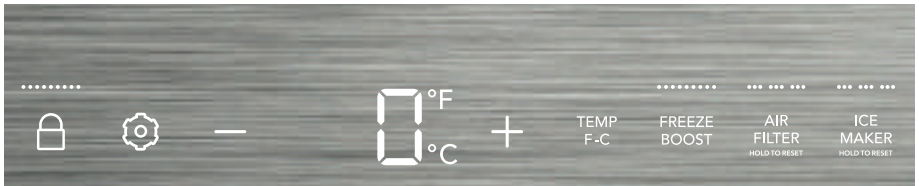

**Sb** appears on the appliance control display indicating the unit is in the Sabbath Mode.



For further assistance, guidelines of proper usage and a complete list of models with the Sabbath feature, please visit the web at [star-k.org](http://star-k.org).

The unit stays in the Sabbath Mode after a power failure recovery. You must deactivate it with the buttons on the appliance control display.



### NOTE

While in the Sabbath Mode, neither the lights nor the appliance control display will work (except to exit the Sabbath Mode) until you deactivate the Sabbath Mode. Additionally, the ice maker will stop ice production when you activate Sabbath Mode. The appliance stays in the Sabbath Mode after power failure recovery. You must deactivate it with the buttons on the appliance control display.

# 22

## CONTROLS AND SETTINGS

---

### To exit Sabbath Mode

Simultaneously press and hold **—** and **TEMP F/C** for 5 seconds.



The appliance control display shows all of the icons depending on your model.



In the Sabbath Mode, the **HIGH TEMP** alarm is active for health reasons. For example, if you leave the door ajar, the **HIGH TEMP** alarm activates. The freezer functions normally once you close the door, without any violation of the Sabbath/holidays. The **HIGH TEMP** alarm comes on when the cabinet temperature is outside the safe zone for 20 minutes. The alarm silences itself after 10 minutes while the **HIGH TEMP** icon stays lit until you exit the Sabbath Mode.

All buttons are disabled, and all sounds (except the **HIGH TEMP** alert\* and the combination to exit Sabbath Mode) are muted. Only the **HIGH TEMP** alert illuminates until you deactivate the Sabbath Mode.

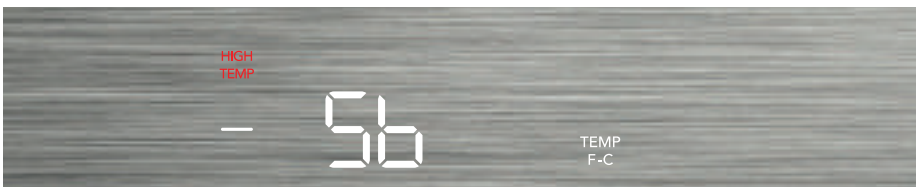

Your appliance has an automatic ice maker that provides a sufficient supply of ice for normal use. **The unit will not produce ice during the first 24 hours of initial operation.**

### Turning Your Ice Maker On

After you have completed connecting the plumbing, you must open the water supply valve. To turn the ice maker on, press  on the appliance control display. Then press and hold **ICE MAKER** until the LEDs above **ICE MAKER** illuminate. New plumbing connections may cause the first production of ice cubes to be discolored or have an odd flavor. Discard these first cubes until the cubes produced are free of discoloration and taste.

### Turning Your Ice Maker Off

To turn the ice maker off, press  on the appliance control display. Then press and hold **ICE MAKER** until the LEDs above **ICE MAKER** are turned off. Separately, the ice maker automatically stops producing ice when the bin is full and then restarts when the level of ice drops. **Note:** when you turn off the ice maker at the appliance control display, the ice maker will not produce ice at all

### Ice Maker Tips

- If the ice maker will be turned off for a long period of time, turn the water supply valve to the closed position.
- Ice cubes stored too long may develop an odd flavor. Empty the ice bin. The ice maker will then produce more ice.
- Occasionally shake the ice container to keep ice separated.
- Keep the ice maker off until the ice maker is connected to the water supply or whenever the water supply is turned off.
- The following sounds are normal when the ice maker is operating:
  - Motor running
  - Ice loosening from tray
  - Ice dropping into ice container
  - Running water
  - Water valve opening or closing



### IMPORTANT

To ensure proper function of your ice maker, hook up the water supply immediately or turn off the ice maker (see **ICE MAKER** in **CONTROLS AND SETTINGS**).



### CAUTION

- DO NOT place the ice bin in the dishwasher.
- Wash the ice bin in warm water with mild detergent. Rinse well and dry.
- Turn off the ice maker when cleaning the freezer and during vacations.

### Ice Maker Storage Bin

#### Capacity

The ice maker should produce about 4.5 lbs of ice per 24 hours, depending on conditions of use.

#### How much ice can be stored in the ice bins?

When completely full, the bins hold about 8 lbs of ice.

# 24 STORAGE FEATURES



## IMPORTANT

When placing frozen items in the freezer, leave a gap of at least 2" at the top of the freezer. Stacking items to the top can cause ice buildup.

## Full Width Cantilever Shelves

You can move Multi-position adjustable shelves to any position for larger or smaller packages. You may remove and discard the shipping spacers that stabilize the shelves for shipping.

### To Adjust The Shelves

- Remove all food from the shelf.
- Shelves are heavy. We recommend using both hands to install and remove the shelf. We recommend placing one hand centered on the front trim and the other hand centered under the rear of the shelf.
- Lift the front edge up at a slight angle to release the tabs from the slots in the rear. Continue lifting the shelf vertically until the shelf clears the built-in shelf supports located on the sides of the cabinet. Then pull the shelf out.
- Replace the shelf by inserting the mounting bracket hooks into the desired support slots at the rear.
- Carefully lower the shelf and lock into position.

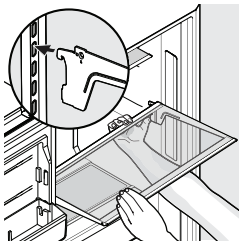

## IMPORTANT

Carefully handle the shelves when removing and installing them to prevent making contact with the cabinet liners and the stainless steel rear air tower.

Do not block the air-flow vents located on the back wall of the air-tower with the shelves.

## Soft Freeze Zone

The soft freeze zone drawer remains slightly warmer than the freezer interior for convenient storage of soft freeze items such as ice cream.

We recommend opening and closing the drawer by grabbing the center of the drawer handle.

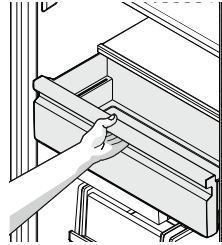

### To remove the soft freeze drawer:

1. Remove all items from the drawer.
2. We recommend using both hands to remove and install the drawer from the slide rail supports. Remove the drawer by pulling it out until it is fully extended. Lift up on the front of the handle area and lift it out.
3. Carefully handle the drawer to prevent making contact with the cabinet liner during removal and installation.

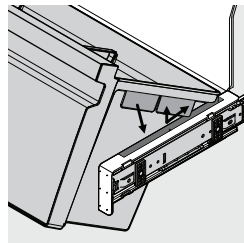

## Slide-Out Shelf with Removable Ice Storage Bins

The slide-out shelf provides easy access to the removable ice storage bin. You should return it back to its fully closed position to allow the ice maker to properly dispense ice cubes. If you do not fully close the slide-out shelf, it will cause ice to be dispensed outside the ice bin, possibly causing the need for a service call.

The removeable storage bins hold ice from the ice maker. The left-hand bin is in the primary location for holding dispensed ice. If you prefer more ice, simply move the full bin to the right, and put the other empty bin in place on the left-hand side for holding newly dispensed ice. You can use the right-hand bin for additional storage when not holding ice. Or you can remove the right-hand bin in order to use the slide-out shelf for storage.

We recommend opening and closing the slide-out shelf by grabbing the center of the shelf handle.

### To remove the slide-out shelf:

1. Remove all items from the shelf.
2. We recommend using both hands to remove and install the shelf from the slide rail supports. Remove the shelf by pulling it out until it is fully extended. Lift up on the front of the handle area and lift it out.
3. Carefully handle the slide-out shelf to prevent making contact with the cabinet liner during removal and installation.

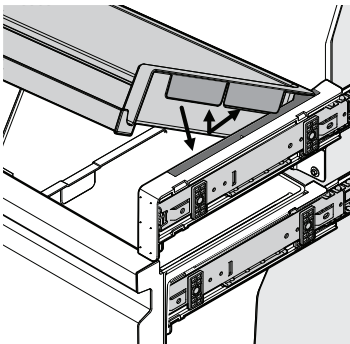

### To remove the ice storage bins:

1. We recommend using both hands to remove and install the ice bins. Remove the bins by pulling the slide-out shelf out until it is fully extended and lifting the ice bin up and out.

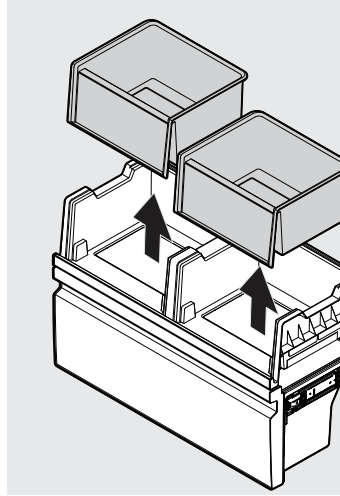

2. Carefully handle the slide-out shelf to prevent making contact with the cabinet liner during removal and installation.

## Lower Drawer with Dividers

The lower drawer with dividers works great for food that may need to be separated. You can use the drawer with the dividers or without by adding or the inserts.

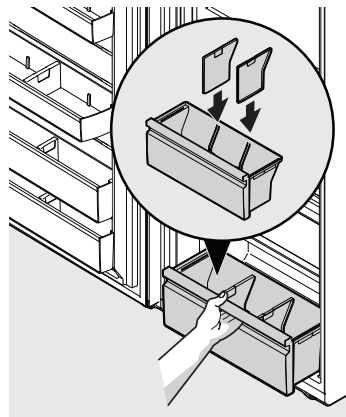

# 26 STORAGE FEATURES

We recommend opening and closing the lower drawer by grabbing the center of the handle.

## To remove the lower drawer:

1. Remove all items from the lower drawer.
2. We recommend using both hands to remove and install the lower drawer from slide rail supports. Remove the drawer by pulling it out until it is fully extended. Lift up on the front of the handle trim and lift it out.
3. Carefully handle the drawer to prevent making contact with the cabinet liner during removal and installation.

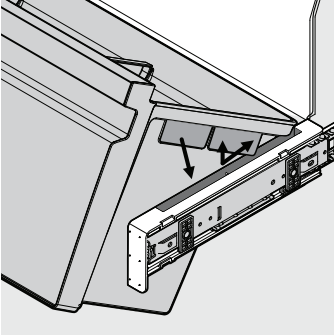

## Adjustable Door Bins with Dividers

The adjustable door bins are specially designed to hold large containers or storage bags. You can use each bin type only in the zone indicated below so the door can close correctly. Your unit has 2 Half-Gallon Door Bins (Zone A), a Gallon Door Bin (Zone B), and 2 Tall Item Door Bins (Zone C).

## To remove a door bin:

- Grasp the ends of the door bin.
- Lift the door bin up until it clears the locking lugs.
- Pull the door bin straight out toward you.

## To install a door bin:

- Make sure the locking feature on the bin aligns with the mounting lugs on the door.
- Lower the door bin into the mounting lugs until it locks in place.

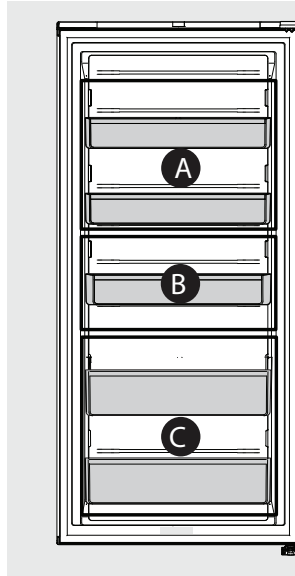

Customize your unit to fit different sized items as your needs change with door bin dividers.

**To remove,** grasp the divider and pull it up until it disengages with the door bin.

**To install,** slide the divider down into the corresponding door bin alignment features until it is fully placed.

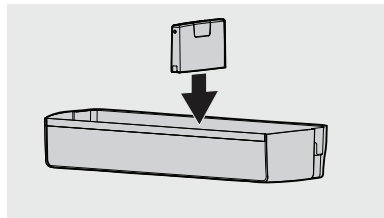



- Locate the appliance in the coolest part of the room, out of direct sunlight, and away from heating ducts or registers. Do not place the unit next to heat-producing appliances such as a range, oven, or dishwasher. If this is not possible, a section of cabinetry or an added layer of insulation between the two appliances will help the unit operate more efficiently.
  - Level the appliance so the door closes tightly.
  - Refer to **CONTROLS AND SETTINGS** for the suggested temperature control settings.
  - Do not overcrowd the unit or block cold air vents. Doing so causes the appliance to run longer and use more energy.
  - Cover foods and wipe containers dry before placing them in the appliance. This cuts down on moisture build-up inside the unit.
  - Organize the appliance to reduce door openings. Remove as many items as needed at one time and close the door as soon as possible.
-

# 28 FILTER REPLACEMENT

## PureAir Ultra II™ Air Filter

With more power to clear the air, Frigidaire air filters banish pungent smells and work better than baking soda. **PureAir Ultra II** Air Filters:

- **Are more powerful than baking soda**  
Keep your unit fresh for up to 6 months.
- **Capture and keep odors away**  
Absorb undesirable smells with carbon technology.

Your appliance control display is equipped with a **REPLACE AIR FILTER** indicator to remind you to change your filter every 6 months to ensure optimal filtering of appliance odors. Your **PureAir Ultra II** Air Filter is included in your Literature Pack. To order replacement filters, please visit our online store at [Frigidaire.com](http://Frigidaire.com), by calling toll-free at 1 (800) 372-4432, or by visiting the dealer where you purchased your unit.

Here are the product numbers to request when ordering:

**PureAir Ultra II™** Air Filter  
**PAULTRA2™**

## Installing or replacing the air filter

Your air filter housing is located in the upper rear center of the cabinet, behind a removable stainless steel decorative plate. To install the air filter element:

1. Grab the cover with your hand, pulling until it releases from the fixed air filter housing. The air filter element is mounted on the back of the cover.
2. If the filter was previously installed, remove the old filter and discard it.
3. Unpack the new filter and snap it into the filter cover. The open face (carbon media) of the filter should be installed facing outward in the cover.
4. Reattach the air filter cover to the air filter housing by aligning the cover to the housing and firmly pushing it until it snaps in place.
5. Press and hold **REPLACE AIR FILTER** on the appliance control display to reset it.

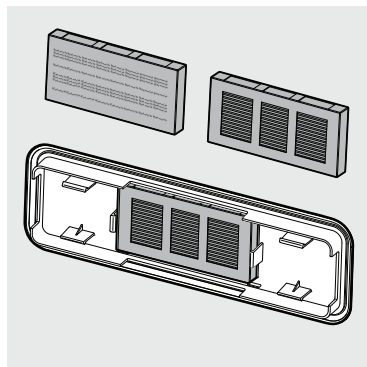
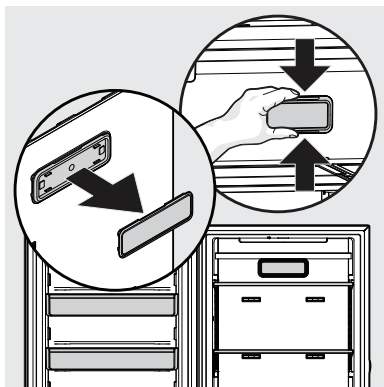

## Protecting your investment

Keeping your appliance clean maintains its appearance and prevents odor build-up. Wipe up any spills immediately and clean the appliance at least twice a year. When cleaning, take the following precautions:

- Never use CHLORIDE or cleaners with bleach to clean stainless steel.
- Do not wash any removable parts in a dishwasher.
- Always unplug the electrical power cord from the wall outlet before cleaning.
- Remove adhesive labels by hand. Do not use razor blades or other sharp instruments which can scratch the appliance surface.
- Do not remove the serial plate.

Do not use abrasive cleaners such as window sprays, scouring cleansers, brushes, flammable fluids, cleaning waxes, concentrated detergents, bleaches or cleansers containing petroleum products on plastic parts, interior doors, gaskets or cabinet liners. Do not use paper towels, metallic scouring pads, or other abrasive cleaning materials or strong alkaline solutions.



### CAUTION

Damp objects stick to cold metal surfaces. Do not touch interior metal surfaces with wet or damp hands.



### CAUTION

When moving the unit, pull it straight out. Do not shift the appliance from side to side as this may tear or gouge the floor covering.

## Vacation and Moving Tips

**Short Vacations:** Leave the unit operating during vacations of less than 3 weeks.

**Long Vacations:** If the appliance will not be used for several months:

- Remove all food and unplug the power cord.
- Clean and dry the interior thoroughly.
- Leave the door open slightly, blocking it open if necessary, to prevent odor and mold growth.

**Moving:** When moving the unit, follow these guidelines to prevent damage:

- Disconnect the power cord plug from the wall outlet.
- Remove food, and then defrost and clean the appliance.
- Secure all loose items such as base panel, baskets, and shelves by taping them securely in place to prevent damage.
- In the moving vehicle, secure the unit in an upright position to prevent movement. Also protect the outside of the appliance with a blanket, or similar item.



### NOTE

- To disconnect electrical power to the lights or other electrical components, unplug the unit or switch the breaker supplying power to the unit to the off position.
- Do not use razor blades or other sharp instruments which can scratch the appliance surface when removing adhesive labels. Remove any glue left from tape or labels with a mixture of warm water and mild detergent, or touch the glue residue with the sticky side of tape you have already removed. Do not remove the serial plate.

Care & Cleaning Tips		
Part	What To Use	Tips and Precautions
Interior & Door Liners	<ul style="list-style-type: none"> <li>• Soap and water</li> <li>• Baking soda and water</li> </ul>	Use 2 tbsp of baking soda in 1 qt of warm water. Be sure to wring excess water out of the sponge or cloth before cleaning around controls, light bulb or any electrical part.
Door Gaskets	<ul style="list-style-type: none"> <li>• Soap and water</li> </ul>	Wipe gaskets with a clean soft cloth.
Drawers & Bins	<ul style="list-style-type: none"> <li>• Soap and water</li> </ul>	Use a soft cloth to clean the drawer runners and tracks. Do not wash any removable items (bins, drawers, etc.) in dishwasher.
Exterior & Handles	<ul style="list-style-type: none"> <li>• Soap and water</li> <li>• Non-Abrasive Glass Cleaner</li> </ul>	Do not use commercial household cleaners, ammonia, or alcohol to clean handles. Use a soft cloth to clean smooth handles. Do not use a dry cloth to clean smooth doors.
Metal Shelves	<ul style="list-style-type: none"> <li>• Soap and water</li> </ul>	Clean with a soft cloth
Door & Stainless Steel Air Tower Cover	<ul style="list-style-type: none"> <li>• Soap and water</li> <li>• Stainless steel cleaners</li> </ul>	<p>Clean with non-abrasive, soapy water and a dishcloth. Rinse with clean water and a soft cloth. Use a non-abrasive stainless steel cleaner. You can purchase these cleaners at most home improvement or major department stores. Always follow the manufacturer's instructions. Do not use household cleaners containing ammonia or bleach.</p> <p><b>NOTE:</b> Always clean, wipe and dry with the grain to prevent scratching.</p>

Let us help you troubleshoot your concern! This section will help you with common issues. If you need us, visit our website, chat with an agent, or call us. We may be able to help you avoid a service visit. If you do need service, we can get that started for you!

1-800-374-4432 (United States)

1-800-265-8352 (Canada)

Frigidaire.com

Frigidaire.ca

CONCERN	CAUSE	SOLUTION
<b>APPLIANCE OPERATION</b>		
<b>Appliance does not run.</b>	<ul style="list-style-type: none"> <li>Appliance may not be plugged in or plug is loose.</li> <li>House fuse blown or tripped circuit breaker.</li> <li>Power outage.</li> </ul>	<ul style="list-style-type: none"> <li>Appliance must be plugged into a dedicated circuit with standard outlet. Contact a certified electrician to check.</li> <li>Ensure plug is tightly pushed into outlet.</li> <li>Check/replace fuse with a 15-amp time-delay fuse. Reset circuit breaker.</li> <li>Check house lights. Call the local electric company.</li> </ul>
<b>Appliance temperature is colder than preferred.</b>	<ul style="list-style-type: none"> <li>The freezer temperature is set too low.</li> </ul>	<ul style="list-style-type: none"> <li>Check freezer temperatures and adjust the temperature control as needed.</li> </ul>
<b>Appliance temperature is warmer than preferred.</b>	<ul style="list-style-type: none"> <li>The freezer temperature is set too high.</li> <li>The door is ajar.</li> </ul>	<ul style="list-style-type: none"> <li>Set control to a colder setting until appliance temperature is satisfactory. Allow 24 hours for the temperature to stabilize.</li> <li>Make sure the door is completely closed and sealed.</li> </ul>
<b>Appliance is noisy or vibrates.</b>	<ul style="list-style-type: none"> <li>The cabinet is not level.</li> <li>Floor is weak.</li> </ul>	<ul style="list-style-type: none"> <li>Adjust the leveling feet. See <b>Leveling</b> in <b>INSTALLATION</b>.</li> </ul>
<b>Appliance runs too much or too long.</b>	<ul style="list-style-type: none"> <li>Room or outside weather is hot.</li> <li>Appliance has recently been disconnected for a period of time.</li> <li>Large amounts of warm or hot food have been stored recently.</li> <li>Door is opened too frequently or too long.</li> <li>Door may be slightly open.</li> <li>Temperature control is set too low.</li> <li>Gaskets are dirty, worn, cracked, or poorly fitted.</li> </ul>	<ul style="list-style-type: none"> <li>It's normal for the appliance to work longer under these conditions.</li> <li>It may take 24 hours for the appliance to cool down completely.</li> <li>Warm food will cause appliance to run more until the desired temperature is reached.</li> <li>Warm air entering the appliance causes it to run more. Open door less often.</li> <li>See <b>DOOR PROBLEMS</b> in <b>TROUBLESHOOTING</b>.</li> <li>Turn control knob to a warmer setting. Allow several hours for the temperature to stabilize.</li> <li>Clean or change gasket. (See <b>Care &amp; Cleaning Tips</b> in <b>CARE AND CLEANING</b>). Worn, cracked or poorly fitting gaskets should be replaced.</li> </ul>
<b>APPLIANCE TEMPERATURES</b>		
<b>Interior appliance temperature is too cold.</b>	<ul style="list-style-type: none"> <li>Temperature control is set too low.</li> </ul>	<ul style="list-style-type: none"> <li>Set control to a warmer setting. Allow several hours for temperature to stabilize.</li> </ul>

# 32 TROUBLESHOOTING

CONCERN	CAUSE	SOLUTION
<b>Temperature inside appliance is too warm.</b>	<ul style="list-style-type: none"> <li>• Temperature control is set too warm.</li> <li>• Door is opened too frequently or too long.</li> <li>• Door may not be seating properly.</li> <li>• Large amount of warm or hot food has been stored recently.</li> <li>• Unit has recently been disconnected for a period of time.</li> </ul>	<ul style="list-style-type: none"> <li>• Turn control to a colder setting. Allow several hours for temperature to stabilize.</li> <li>• Warm air enters the appliance every time the door is opened. Open door less often.</li> <li>• Look for food items on the shelves or in the door bins keeping the door from closing completely.</li> <li>• Wait until the appliance has had a chance to reach its selected temperature.</li> <li>• Appliance may take up to 24 hours to cool down completely.</li> </ul>
<b>🔒 is displayed on control.</b>	<ul style="list-style-type: none"> <li>• The control has been locked.</li> </ul>	<ul style="list-style-type: none"> <li>• Press 🔒 for 3 seconds to unlock.</li> </ul>
<b>Sb is displayed on control .</b>	<ul style="list-style-type: none"> <li>• The control is in Sabbath Mode.</li> </ul>	<ul style="list-style-type: none"> <li>• Press — and <b>TEMP F/C</b> for 5 seconds.</li> </ul>
<b>DEMO is displayed on control.</b>	<ul style="list-style-type: none"> <li>• The control is in <b>DEMO</b> Mode. Cooling has stopped functioning.</li> </ul>	<ul style="list-style-type: none"> <li>• To exit <b>DEMO</b> Mode, press and hold — and <b>ICE MAKER</b> for 10 seconds.</li> </ul>
<b>AUTOMATIC ICE MAKER</b>		
<b>Ice maker is not making any ice.</b>	<ul style="list-style-type: none"> <li>• Ice maker is turned off.</li> </ul>	<ul style="list-style-type: none"> <li>• Turn on the ice maker. Press and hold the <b>On/Off</b> button for 3 seconds until the indicator light is on.</li> </ul>
<b>Ice maker is not making enough ice.</b>	<ul style="list-style-type: none"> <li>• Freezer control is set too warm.</li> </ul>	<ul style="list-style-type: none"> <li>• Set freezer control to a colder setting to improve performance of the ice maker. Allow 24 hour for temperature to stabilize.</li> </ul>
<b>Ice cubes are freezing together.</b>	<ul style="list-style-type: none"> <li>• Ice cubes are not being used frequently enough.</li> <li>• Ice cubes are hollow (partially frozen cubes with water inside).</li> <li>• Freezer control is set too warm.</li> </ul>	<ul style="list-style-type: none"> <li>• Remove ice container and discard ice from the container. The ice maker will produce fresh ice.</li> <li>• Ice and water filter cartridge may be clogged. Replace filter cartridge.</li> <li>• Set the freezer control to a colder setting. Allow 24 hours for temperature to stabilize.</li> </ul>
<b>SOUND AND NOISE</b>		
<b>Louder sound levels whenever appliance is on.</b>	<ul style="list-style-type: none"> <li>• Modern freezers have increased storage capacity and more stable temperatures. They require heavy-duty compressors.</li> </ul>	<ul style="list-style-type: none"> <li>• This is normal. When the surrounding noise level is low, you might hear the compressor running while it cools the interior.</li> </ul>
<b>Popping or cracking sound when compressor comes on. Bubbling or gurgling sound.</b>	<ul style="list-style-type: none"> <li>• Metal parts undergo expansion and contraction, as in hot water pipes.</li> <li>• Refrigerant (used to cool the freezer) is circulating throughout the system.</li> </ul>	<ul style="list-style-type: none"> <li>• This is normal. Sound will level off or disappear as appliance continues to run.</li> <li>• This is normal.</li> </ul>

<b>CONCERN</b>	<b>CAUSE</b>	<b>SOLUTION</b>
<b>Vibrating or rattling noise.</b>	<ul style="list-style-type: none"> <li>• Appliance is not level. It rocks on the floor when it is moved slightly.</li> <li>• Floor is uneven or weak.</li> <li>• Appliance is touching the wall.</li> </ul>	<ul style="list-style-type: none"> <li>• Level the appliance. Refer to <b>Leveling</b> in <b>INSTALLATION</b>.</li> <li>• Ensure floor can adequately support the appliance. Level the appliance by putting wood or metal shims under part of the appliance.</li> <li>• Re-level appliance or move appliance slightly. Refer to <b>Leveling</b> in <b>INSTALLATION</b>.</li> </ul>
<b>WATER / MOISTURE / FROST INSIDE APPLIANCE</b>		
<b>Moisture forms on inside appliance walls.</b>	<ul style="list-style-type: none"> <li>• Weather is hot and humid, which increases internal rate of frost buildup.</li> <li>• Door is slightly open.</li> <li>• Door is kept open too long.</li> </ul>	<ul style="list-style-type: none"> <li>• This is normal.</li> <li>• Look for food items on the shelves or in the door bins keeping the door from closing completely.</li> <li>• Open the door less often.</li> </ul>
<b>ODOR IN APPLIANCE</b>		
<b>Odors in appliance.</b>	<ul style="list-style-type: none"> <li>• Interior needs to be cleaned.</li> <li>• Foods with strong odors are in the appliance.</li> </ul>	<ul style="list-style-type: none"> <li>• Clean interior with sponge, warm water, and baking soda. Replace air filter.</li> <li>• Cover the food tightly.</li> </ul>
<b>DOOR PROBLEMS</b>		
<b>Door will not close.</b>	<ul style="list-style-type: none"> <li>• Appliance is not level. It rocks on the floor when it is moved slightly.</li> <li>• Floor is uneven or weak.</li> </ul>	<ul style="list-style-type: none"> <li>• This condition can force the cabinet out of square and misalign the door. Refer to <b>Leveling</b> in <b>INSTALLATION</b>.</li> <li>• Ensure floor can adequately support appliance. Level the appliance by putting wood or metal shims under part of the appliance.</li> <li>• Look for food items on the shelves or in the door bins keeping the door from closing completely.</li> </ul>
<b>LIGHTING PROBLEMS</b>		
<b>Cabinet light is not working.</b>	<ul style="list-style-type: none"> <li>• LED is burned out.</li> </ul>	<ul style="list-style-type: none"> <li>• Call a Frigidaire service technician.</li> </ul>

# 34 LIMITED WARRANTY

Your appliance is covered by a two-year limited warranty. For two years from your date of delivery, Electrolux will pay all costs for repairing or replacing any parts of this appliance that prove to be defective in materials or workmanship when such appliance is installed, used and maintained in accordance with the provided instructions.

## Exclusions

### This warranty does not cover the following:

1. Products with original serial numbers that have been removed, altered or cannot be readily determined.
2. Product that has been transferred from its original owner to another party or removed outside the USA or Canada.
3. Rust on the interior or exterior of the unit.
4. Products purchased "as-is" are not covered by this warranty.
5. Food loss due to any Appliance or freezer failures.
6. Products used in a commercial setting.
7. Service calls which do not involve malfunction or defects in materials or workmanship, or for appliances not in ordinary household use or used other than in accordance with the provided instructions.
8. Service calls to correct the installation of your appliance or to instruct you how to use your appliance.
9. Expenses for making the appliance accessible for servicing, such as removal of trim, cupboards, shelves, etc., which are not a part of the appliance when it is shipped from the factory.
10. Service calls to repair or replace appliance light bulbs, air filters, water filters, other consumables, or knobs, handles, or other cosmetic parts.
11. Surcharges including, but not limited to, any after hour, weekend, or holiday service calls, tolls, ferry trip charges, or mileage expense for service calls to remote areas, including the state of Alaska.
12. Damages to the finish of appliance or home incurred during installation, including but not limited to floors, cabinets, walls, etc.
13. Damages caused by: services performed by unauthorized service companies; use of parts other than genuine Electrolux parts or parts obtained from persons other than authorized service companies; or external causes such as abuse, misuse, inadequate power supply, accidents, fires, or acts of God.

## DISCLAIMER OF IMPLIED WARRANTIES; LIMITATION OF REMEDIES

CUSTOMER'S SOLE AND EXCLUSIVE REMEDY UNDER THIS LIMITED WARRANTY SHALL BE PRODUCT REPAIR OR REPLACEMENT AS PROVIDED HEREIN. CLAIMS BASED ON IMPLIED WARRANTIES, INCLUDING WARRANTIES OF MERCHANTABILITY OR FITNESS FOR A PARTICULAR PURPOSE, ARE LIMITED TO ONE YEAR OR THE SHORTEST PERIOD ALLOWED BY LAW, BUT NOT LESS THAN ONE YEAR. ELECTROLUX SHALL NOT BE LIABLE FOR CONSEQUENTIAL OR INCIDENTAL DAMAGES SUCH AS PROPERTY DAMAGE AND INCIDENTAL EXPENSES RESULTING FROM ANY BREACH OF THIS WRITTEN LIMITED WARRANTY OR ANY IMPLIED WARRANTY. SOME STATES AND PROVINCES DO NOT ALLOW THE EXCLUSION OR LIMITATION OF INCIDENTAL OR CONSEQUENTIAL DAMAGES, OR LIMITATIONS ON THE DURATION OF IMPLIED WARRANTIES, SO THESE LIMITATIONS OR EXCLUSIONS MAY NOT APPLY TO YOU. THIS WRITTEN WARRANTY GIVES YOU SPECIFIC LEGAL RIGHTS. YOU MAY ALSO HAVE OTHER RIGHTS THAT VARY FROM STATE TO STATE.

## If You Need Service

Keep your receipt, delivery slip, or some other appropriate payment record to establish the warranty period should service be required. If service is performed, it is in your best interest to obtain and keep all receipts. Service under this warranty must be obtained by contacting Electrolux at the addresses or phone numbers below.

This warranty only applies in the USA and Canada. In the USA, your appliance is warranted by Electrolux Major Appliances North America, a division of Electrolux Home Products, Inc. In Canada, your appliance is warranted by Electrolux Canada Corp. Electrolux authorizes no person to change or add to any obligations under this warranty. Obligations for service and parts under this warranty must be performed by Electrolux or an authorized service company. Product features or specifications as described or illustrated are subject to change without notice.

**USA**  
**1-800-374-4432**  
Frigidaire  
10200 David Taylor Drive  
Charlotte, NC 28262



**Electrolux**

**Canada**  
**1.800.265.8352**  
Electrolux Canada Corp.  
5855 Terry Fox Way  
Mississauga, Ontario, Canada  
L5V 3E4



# FRIGIDAIRE®

welcome **home**

Our home is your home. Visit us if you need help with any of these things:



owner support



accessories



service



registration

(See your registration card for more information.)

Frigidaire.com  
1-800-374-4432

Frigidaire.ca  
1-800-265-8352