

Air Purifier

use & care

Introduction.....	2	Care And Cleaning.....	9
Important Safety Instructions.....	3	Storage.....	10
Parts and Feature List.....	5	Before You Call.....	11
Operating Instructions.....	6	Warranty.....	13

2

INTRODUCTION

Welcome to our *family*

Thank you for bringing Frigidaire® into your home! We see your purchase as the beginning of a long relationship together.

This manual is your resource for the use and care of your product. Please read it before using your appliance. Keep it handy for quick reference. If something doesn't seem right, the troubleshooting section will help you with common issues.

FAQs, helpful tips and videos, cleaning products, and kitchen and home accessories are available at www.frigidaire.com.

We are here for you! Visit our website, chat with an agent, or call us if you need help. We may be able to help you avoid a service visit. If you do need service, we can get that started for you.

Let's make it official! Be sure to register your product.

Keep your product info here so it's easy to find.

Model Number _____

Serial Number _____

Purchase Date _____



SAFETY INFORMATION

This USER MANUAL provides specific operating instructions for your model. Use the unit only as instructed in this USER MANUAL. These instructions are not meant to cover every possible condition and situation that may occur. Common sense and caution must be practiced when installing, operating, and maintaining any appliance.

READ AND SAVE THESE INSTRUCTIONS

The electronic copy can be obtained on www.Frigidaire.com



WARNING

- Do not store or use gasoline or other flammable vapors and liquids in the vicinity of this or any other appliance. Read product labels for flammability and other warnings.
- Do not let water or any other liquid or flammable detergent enter the appliance to avoid electric shock and/or a fire hazard.
- Do not touch the fan blade when removing the filter.
- Disconnect the appliance from the power supply before servicing.
- Do not operate the appliance with a damaged cord, plug or adapter. Return to an authorized service facility for examination and repair.
- Do not run cord under carpeting. Do not cover cord with throw rugs, runners, or similar covering. Do not route cord under furniture or appliances. Arrange cord away from traffic area and where it will not be tripped over.
- To reduce the risk of fire, electric shock or injury to persons, do not use replacement parts that have not been recommended by the manufacturer.



WARNING

Children and Vulnerable People Safety

- **WARNING!** Risk of suffocation, injury or permanent disability.
- This appliance can be used by children aged from 8 years and above and persons with reduced physical, sensory or mental capabilities or lack of experience and knowledge if they have been given supervision or instruction concerning use of the appliance in a safe way and understand the hazards involved.
- Children shall not play with the appliance.
- Cleaning and user maintenance shall not be made by children without supervision.
- Children under 3 years of age should be kept away from the appliance unless continuously supervised.
- Keep all packaging away from children.



SAFETY PRECAUTIONS

- This equipment should be inspected frequently and collected dirt removed from it regularly to prevent excessive accumulation that may result in flashover or a risk of fire.
- **RISK OF ELECTRIC SHOCK** - These servicing instructions are for use by qualified personnel only. To reduce the risk of electric shock, do not perform any servicing other than that contained in the operating instructions unless you are qualified to do so.
- To reduce the risk of electric shock, this equipment has a polarized plug (one blade is wider than the other). This plug will fit in a polarized outlet only one way. If the plug does not fit fully in the outlet, reverse the plug. If it still does not fit, contact qualified personnel to install the proper outlet.
- Do not alter the plug in any way. Do not attempt to defeat this safety feature.
- This device complies with Part 15 of the FCC Rule / ISED standard(s).

4

IMPORTANT SAFETY INSTRUCTIONS

Operation is subject to the following two conditions: (1) this device may not cause harmful interference, and (2) this device must accept any interference received, including interference that may cause undesired operation.

- Changes or modifications not expressly approved by the party responsible for compliance could void the user's authority to operate the equipment.
 - This equipment has been tested and found to comply with the limits for a Class B digital device, pursuant to part 15 of the FCC Rules. These limits are designed to provide reasonable protection against harmful interference in a residential installation. This equipment generates uses and can radiate radio frequency energy and, if not installed and used in accordance with the instructions, may cause harmful interference to radio communications. However, there is no guarantee that interference will not occur in a particular installation. If this equipment does cause harmful interference to radio or television reception, which can be determined by turning the equipment off and on, the user is encouraged to try to correct the interference by one or more of the following measures:
 - Reorient or relocate the receiving antenna.
 - Increase the separation between the equipment and receiver.
 - Connect the equipment into an outlet on a circuit different from that to which the receiver is connected.
 - Consult the dealer or an experienced radio/TV technician for help.
 - To satisfy FCC / IC RF exposure requirements, a separation distance of 20 cm or more should be maintained between the antenna of this device and persons during device operation. To ensure compliance, operations at closer than this distance is not recommended.
-

Parts and Feature List

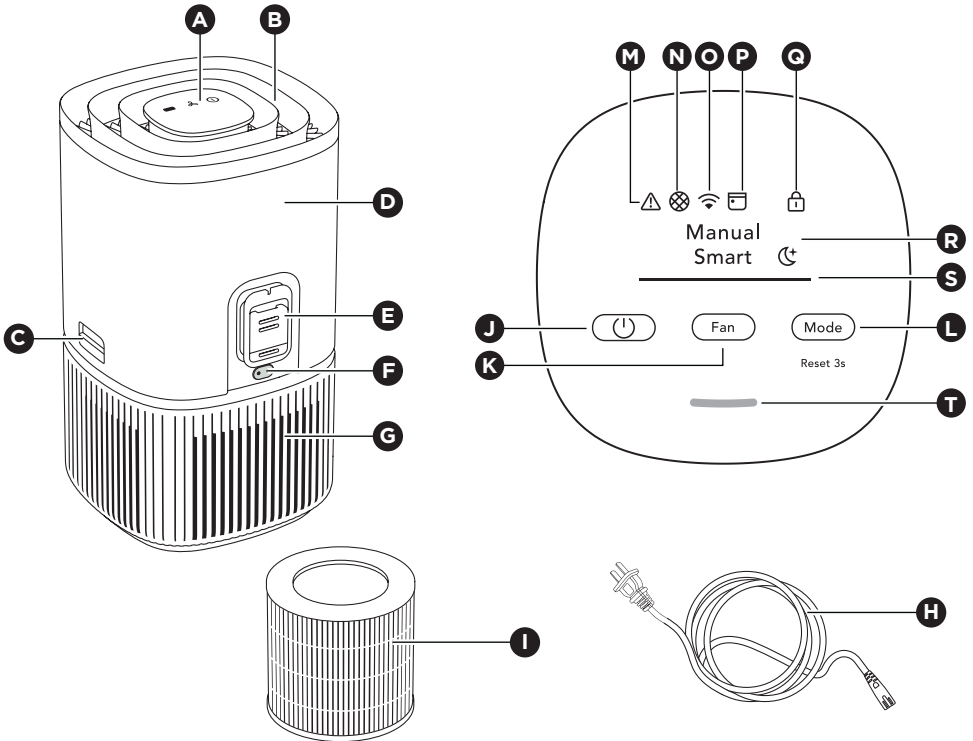

A	Control panel display
B	Air flow guide (Air outlet)
C	Release buttons
D	Main body (top)
E	Sensor box
F	Power cord jack
G	Main body (bottom)
H	Power cord
I	Filter (inside)
J	ON/OFF button

K	FAN button
L	MODE button
M	Warning alert icon
N	Filter change icon
O	Wifi icon*
P	Scheduler icon*
Q	Child lock icon
R	Mode display
S	FAN SPEED indicator
T	Air quality indicator

*Refer to the Quick Start Guide that came with your Smart air purifier for detailed instructions on setting up your air purifier for connected operation from your smart phone or tablet. Unplugging the product will disconnect the remote functions.

6

OPERATING INSTRUCTIONS

When use for the first time

Always use original accessories and spare parts to get the best results. This product is designed with the environment in mind. All plastic parts are marked for recycling purposes.

Remove the plastic protective bag from the HEPA Filter:

Open the product by pressing the release buttons on the sides of the unit, then lift up the top part of the main body.

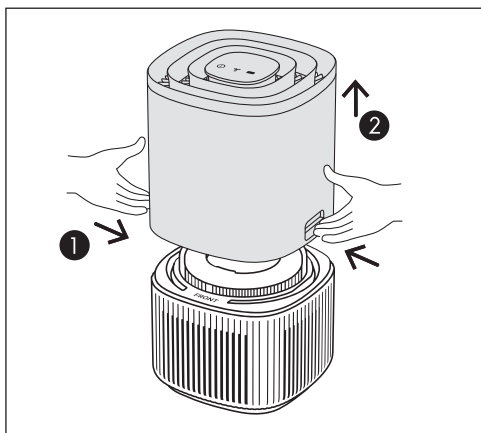

Take out the filter. Carefully remove the plastic bag around the filter and discard appropriately.

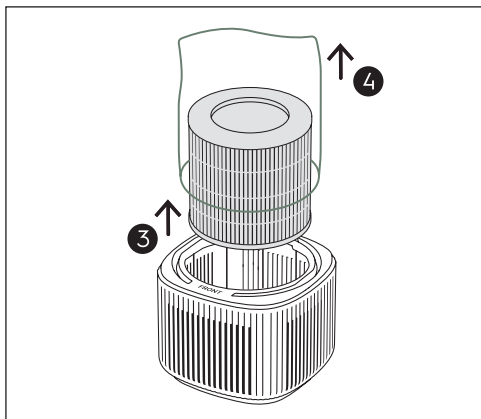

Carefully insert the filter back into the product (either end of the filter works). Make sure that the filter is placed in the center of the cavity.

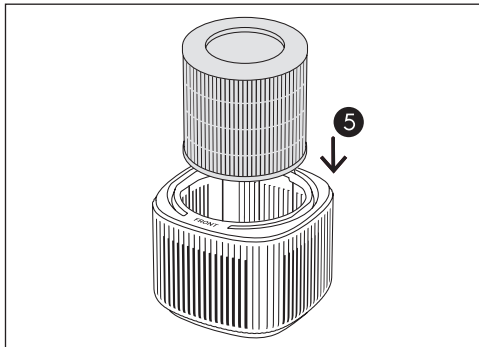

Put back the top part of the main body to close the product till it is securely in place. The mark "FRONT" should be facing the front side of the product.

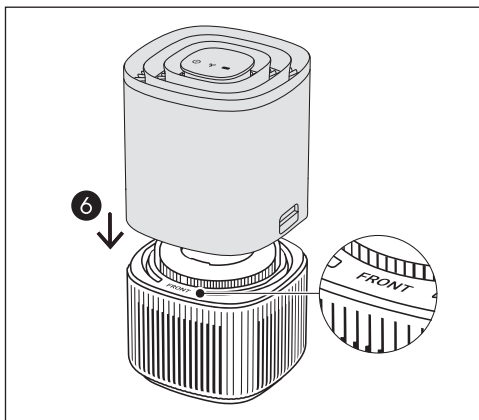

Select location

Place the product according to the instructions below for optimal operation and results:

- Operate the air purifier in an enclosed area. Close all doors, windows, and other openings connecting to the outside of the room.

- Place the air purifier in a location that does not restrict the airflow through the top of the appliance.
- The appliance must be placed on a leveled floor that can support it.
- There should be a minimum of 12 in (30 cm) of clearance around the appliance.

In the SMART mode, the unit will utilize the sensor data as input to decide on the appropriate fan speed, depending on the air quality in the room. The fan speed can not be adjusted by the user under this mode. Please see the AIR QUALITY INDICATOR section for more details.

Operating Instructions

Connect the power plug.

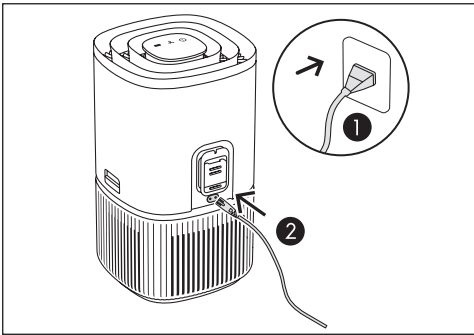

Press the ON/OFF button to turn ON the air purifier, the unit will run in default setting (SMART mode) when using the product the first time. Next time you start the unit it will resume the last settings you had before turning OFF the product.

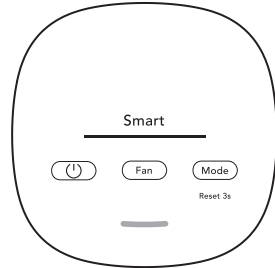

Press the MODE button to choose MANUAL mode.

In the MANUAL mode, the unit will utilize the sensor data as input only to show the air quality level via the air quality indicator but will not self-adjust the fan speed. This mode is best utilized for a quick burst of cleaning, especially when the user anticipates an increase in particulate matter in the room due to household chores (e.g. vacuuming).

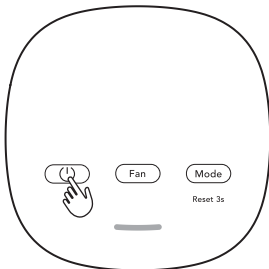

NOTE: When turning ON the air purifier, it will take about 10 seconds for the sensors to calibrate and analyze the air quality. During this time, the air quality indicator will pulsate slowly in white.

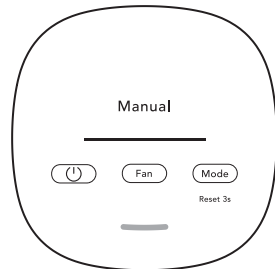

While in MANUAL mode, Press the FAN button to adjust the fan speed, the fan speed indicator will show the fan speed.

The unit has 5 levels fan speed.

NOTE: The unit will ramp up OR down to chosen speed setting gradually.

8

OPERATING INSTRUCTIONS

Press the MODE button to choose Smart Quiet mode.

In the SMART QUIET mode, the unit will run as quiet (control panel indicators dimmed & lower fan speed) as possible to allow for sleep.

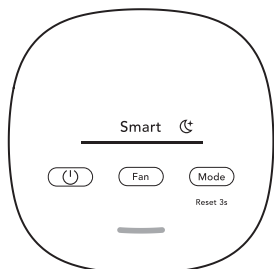

The appliance has an air quality sensor that analyzes the air quality.

The air quality light will show the real-time air quality through different colors of light. As shown below:

LIGHT'S COLOR	PM 2.5 ($\mu\text{g}/\text{m}^3$)	AIR QUALITY
Green	0-12	Good
Yellow	13-35	Average
Orange	36-55	Poor
Red	>56	Very Poor

NOTE: Please ensure regular cleaning of the sensor window to ensure it does not get clogged with dust and sensors keep performing accurately.

FILTER CHANGE and RESET

The filter in the unit cannot be washed, they can only be replaced. The filter change icon will light up to remind you to change your filter. Always ensure the plastic protective bag is removed before its use in the unit.

After the used filter is replaced, long press the MODE button for 3 seconds and filter change indicator will reset.

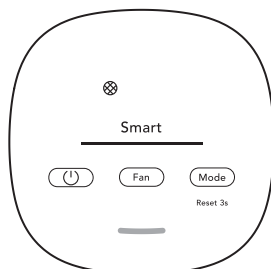

Alert icon

The alert icon will light up to alert you of a possible electrical or electronic error with your unit. Please refer to the App for details on the error type, component details and any mitigating actions. More details can also be found in the ERRORS & TROUBLESHOOTING section below.

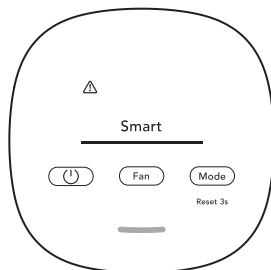

CHILD LOCK

The unit is equipped with a safety lock feature to disable the product control panel to avoid unintended pressing. Press and hold MODE & POWER button simultaneously for 5 seconds to activate or deactivate the child lock feature. The child lock icon will light up when the feature is activated. When the control panel is locked, you can only make changes via App.

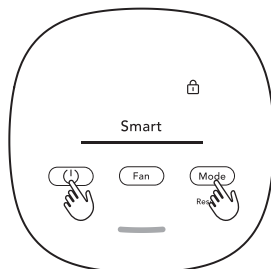

REPLACING FILTER

The filter cannot be washed and must always be replaced when at end of life. Visit our local website to order your replacement filter.

When the filter is at end of life, the filter change icon will light up on the product control panel to indicate the need for replacement. When filter is at end of life, the unit's fan speed may be reduced in SMART mode.

The used filter might be heavily coated with dust and particulate matter so before opening the main unit, please ensure a disposable bag or packaging is at hand to place the used filter in.

Turn OFF the air purifier or unplug the unit before changing the filters. Remove the top part of the main body put it aside. Next remove the filter which is at end of life and place it in a disposable bag at hand. (ref. page 6).

Next, please remove the plastic bag from the replacement filter and insert the filter in to the product. Reinsert back the top part of the main body and turn ON the unit. Reset the filter change icon on the product control panel by long pressing the MODE button for 3 seconds and the App will indicate the same, with a new filter lifetime reading.

Discard the used filter as well as any plastic packaging according to local recycling guidelines.

Note: For the best experience and to secure an uninterrupted use of the air purifier, please monitor the filter's remaining lifetime in the App and order a replacement filter in due time before the remaining filter lifetime reaches 0%.

CARE AND CLEANING

Always unplug the air purifier before cleaning to prevent shock or fire hazards. Never use abrasive, harsh detergents OR wax for cleaning the unit. The high efficiency filters cannot be washed, they must always be replaced when at the end of life.

Cleaning the air quality sensor box and sensor Clean every 1-2 months to maintain the performance of the air quality sensor.

Ensure that the air quality sensor is kept clean and unclogged for optimal performance of the unit. It is natural for dust to accumulate in this area, vacuuming of the sensor box inlet grill with a vacuum cleaner that has a narrow nozzle/brush.

Open the sensor box inlet grill with finger and clean the lens, inlet and outlet with wet cotton swab.

Use dry cotton swab to remove any excess water from the sensor.

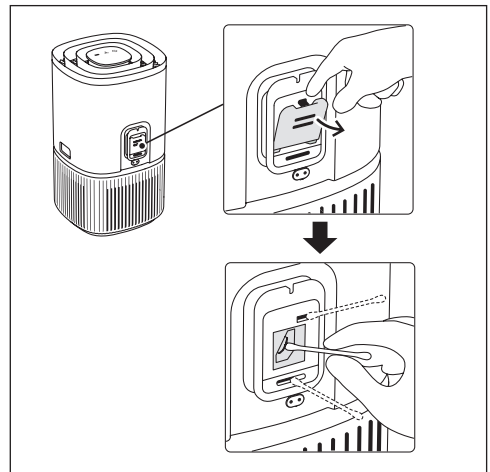

10 CARE AND CLEANING

After having cleaned the sensor box, we recommend to vacuum clean the filter at the same time.

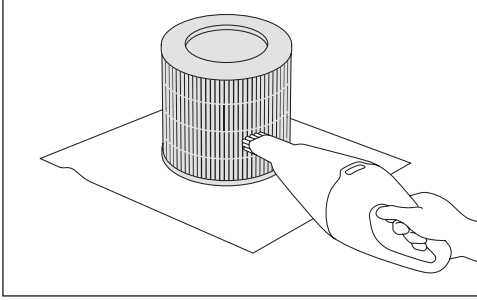

The plastic parts of the unit should be cleaned with an oil-free dry cloth. For stains on plastic parts, use a slightly damp soft microfiber cloth to gently rub against the stain.

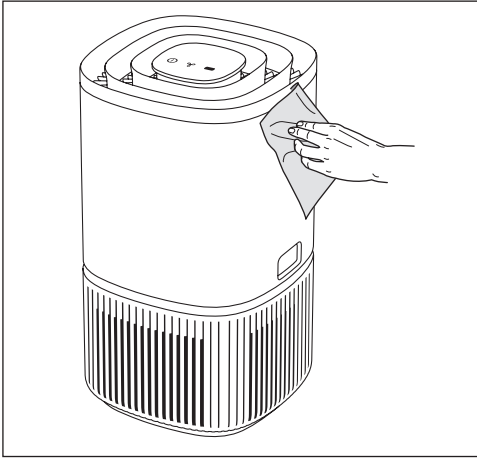

The area around the air inlet on the bottom of the unit may accumulate more dust than some other parts and hence may require more frequent cleaning to ensure optimal performance. The filter is equipped with a mesh filter and should occasionally be wiped off or cleaned with a vacuum cleaner to avoid loss of performance.

STORAGE

If you are not planning to use the appliance for a long time, cover it with plastic or return it to its carton.

When fault indicators show that the system is not operating properly, perform the following check.

The table below is only a limited list. For the latest and complete section on troubleshooting, FAQ and error guide please refer to the corresponding section on our website.

OCCURRENCE	SOLUTION	NOTES
The air purifier's alert icon is lit.	Generally, the unit comes with a variety of sophisticated sensors, electronics and other electrical components and if one of these is malfunctioning, you will see the alert icon on the product control panel light up. For more details on steps to resolve, please head over to the our App and check for details whenever you see this icon lit.	Please have at hand the unit's PNC and SERIAL number if you need to contact service organisation for support.
The air purifier is running at max fan speed all the time for extended periods	If in MANUAL mode, please check the fan speed slider on the product control panel or within App and adjust it to desired level. If in SMART mode, please check air quality indicator on the product control panel or within App - if all PM values are constantly showing 999-1000 without any reduction then most likely the sensor is clogged. Please clean the sensor as described under care and clean section.	The PM sensor in the unit is highly accurate and sensitive and it is normal for the purifier to react to poor air quality by ramping up the fan speed - to get your indoor air quality back to safe levels.
The air purifier is running at lowest fan speed all the time for extended periods	If in MANUAL mode, please check the fan speed on the product control panel display or within App and adjust it to desired level. If in SMART mode, please check air quality indicator on the product control panel or within App - if all PM values are constantly reading very good without any increase then this is normal behavior for the unit - your air quality is very good! If the PM2.5 value is high and the unit is still operating at lowest fan speed, then please check filter change icon on the product control panel or within App. And if lit, please replace used filter with a new one. This should resolve the specific fan speed issue.	The unit is designed so that when a filter is at end of life, it will discourage usage till the filter is replaced, by limiting the fan speed so as not to reintroduce the captured particulate matter back into the air.
The air purifier produces a loud or abnormal noise	Please ensure that the plastic bag around the filter has been removed, ensure the air inlet grill and air outlet grill (top of the unit) are unobstructed and that there is a clearance of at least 30 cm between the unit and the nearest surface.	If there is an abnormal noise in your product, even after checking the steps in the trouble shoot guide, please contact an authorized service center for further support.
I am unable to connect the Air purifier to the App	If you are unable to onboard the unit and connect it to the App after a couple of attempts, then please contact an authorized service center for support.	The WiFi chip in the unit operates only at 2.4Ghz so please ensure your home WiFi is operating at this bandwidth.

12 BEFORE YOU CALL

OCCURRENCE	SOLUTION	NOTES
The air purifier or fan does not operate	Ensure that the unit is receiving power. If needed, try pushing the power plug firmly into the wall socket to check if this resolves the issue. Check that the fuse of your home has not blown or that the circuit breaker has been tripped. Replace fuse or reset circuit breaker if needed.	
The air purifier is running but the air quality does not improve	<p>If in SMART mode, closely monitor the difference in air quality levels within the App for next 20 minutes. If you do not see any improvement of the air quality values in the App during this period then follow the step below.</p> <p>Change to MANUAL mode and adjust the fan speed to a higher level to see if this helps resolve the issue.</p> <p>If you still do not see any improvement. Close any open doors OR windows to the outside of the room and rerun the unit at the highest fan speed for 20 minutes. If this resolves the issue, we recommend that you operate the unit in this sealed environment as much as possible, till the air quality is also at a good level.</p>	If the unit is placed in a room larger than the recommended size, it will take longer for the air quality to improve - please be patient and maintain the unit at the highest feasible speed.
The air purifier produces or emits a strange smell	<p>The first time you run the unit, you may perceive a plastic, glue or paint smell - especially near the air outlet grill - this is unavoidable in some cases (like the 'new car smell') but should disappear quickly.</p> <p>If you perceive a burning smell, please disconnect the unit and contact authorized service center for further support.</p> <p>The VOC filter is in the end of life. Please change to a new filter.</p>	Always ensure that the filter are covered in appropriate packaging while stored away between uses, and that all parts are dry to avoid smell or mould build up.
The filter icon is lit, even though I recently changed the filters	After having changed the filter, long press the MODE button for 3 seconds and the filter indication will be reset.	It is important to turn OFF the unit before changing the filter, in order to reset the product.

If These Solutions Fail, Call 1-800-374-4432(US)/1-800-265-8352(Canada) For Frigidaire® Service.

Limited Warranty 13

Your appliance is covered by a one year limited warranty. For one year from your original date of delivery, Electrolux will pay all costs for repairing or replacing any parts of this appliance that prove to be defective in materials or workmanship when such appliance is installed, used and maintained in accordance with the provided instructions.

Exclusions

This warranty does not cover the following:

1. Products with original serial numbers that have been removed, altered or cannot be readily determined.
2. Product that has been transferred from its original owner to another party or removed outside the USA or Canada.
3. Rust on the interior or exterior of the unit.
4. Products purchased "as-is" are not covered by this warranty.
5. Products used in a commercial setting.
6. Service calls which do not involve malfunction or defects in materials or workmanship, or for appliances not in ordinary household use or used other than in accordance with the provided instructions.
7. Service calls to correct the installation of your appliance or to instruct you how to use your appliance.
8. Expenses for making the appliance accessible for servicing, such as removal of trim, cupboards, shelves, etc., which are not a part of the appliance when it is shipped from the factory.
9. Service calls to repair or replace appliance light bulbs, air filters, other consumables, or knobs, handles, or other cosmetic parts.
10. Pickup and delivery costs; your appliance is designed to be repaired in the home.
11. Surcharges including, but not limited to, any after hour, weekend, or holiday service calls, tolls, ferry trip charges, or mileage expense for service calls to remote areas, including the state of Alaska.
12. Damages to the finish of appliance or home incurred during transportation or installation, including but not limited to floors, cabinets, walls, etc.
13. Damages caused by: services performed by unauthorized service companies; use of parts other than genuine Electrolux parts or parts obtained from persons other than authorized service companies; or external causes such as abuse, misuse, inadequate power supply, accidents, fires, or acts of God.

DISCLAIMER OF IMPLIED WARRANTIES; LIMITATION OF REMEDIES

CUSTOMER'S SOLE AND EXCLUSIVE REMEDY UNDER THIS LIMITED WARRANTY SHALL BE REPAIR OR REPLACEMENT AS PROVIDED HEREIN. CLAIMS BASED ON IMPLIED WARRANTIES, INCLUDING WARRANTIES OF MERCHANTABILITY OR FITNESS FOR A PARTICULAR PURPOSE, ARE LIMITED TO ONE YEAR OR THE SHORTEST PERIOD ALLOWED BY LAW, BUT NOT LESS THAN ONE YEAR. ELECTROLUX SHALL NOT BE LIABLE FOR CONSEQUENTIAL OR INCIDENTAL DAMAGES SUCH AS PROPERTY DAMAGE AND INCIDENTAL EXPENSES RESULTING FROM ANY BREACH OF THIS WRITTEN LIMITED WARRANTY OR ANY IMPLIED WARRANTY. SOME STATES AND PROVINCES DO NOT ALLOW THE EXCLUSION OR LIMITATION OF INCIDENTAL OR CONSEQUENTIAL DAMAGES, OR LIMITATIONS ON THE DURATION OF IMPLIED WARRANTIES, SO THESE LIMITATIONS OR EXCLUSIONS MAY NOT APPLY TO YOU. THIS WRITTEN WARRANTY GIVES YOU SPECIFIC LEGAL RIGHTS. YOU MAY ALSO HAVE OTHER RIGHTS THAT VARY FROM STATE TO STATE.

If You Need Service

Keep your receipt, delivery slip, or some other appropriate payment record to establish the warranty period should service be required. If service is performed, it is in your best interest to obtain and keep all receipts. Service under this warranty must be obtained by contacting Electrolux at the addresses or phone numbers below.

This warranty only applies in the USA, Puerto Rico and Canada. In the USA and Puerto Rico, your appliance is warranted by Electrolux Major Appliances North America, a division of Electrolux Home Products, Inc. In Canada, your appliance is warranted by Electrolux Canada Corp. Electrolux authorizes no person to change or add to any obligations under this warranty. Obligations for service and parts under this warranty must be performed by Electrolux or an authorized service company. Product features or specifications as described or illustrated are subject to change without notice.

USA
1-800-374-4432
Electrolux Appliances North America
10200 David Taylor Drive
Charlotte, NC 28262



Canada
1-800 896 9756
Electrolux Canada Corp.
5855 Terry Fox Way
Mississauga, Ontario,
Canada L5V 3E4

FRIGIDAIRE®

welcome *home*

Our home is your home. Visit us if you need help with any of these things:



owner support



accessories



service



registration

(See your registration card for more information.)

Frigidaire.com
1-800-374-4432

Frigidaire.ca
1-800-265-8352

(Nov. 2024)