

EN User Manual | Fridge Freezer



## Welcome to our family

Thank you for bringing Frigidaire into your home! We see your purchase as the beginning of a long relationship together.

This manual is your resource for the use and care of your product. Please read it before using your appliance. Keep it handy for quick reference. If something doesn't seem right, the troubleshooting section will help you with common issues.

FAQ, helpful tips and videos, cleaning products, and kitchen and home accessories are available at <http://www.frigidaire.com>.

We are here for you! Visit our website, chat with an agent, or call us if you need help. We may be able to help you avoid a service visit. If you do need service, we can get that started for you.

Let's make it official! Be sure to register your product.

## CONTENTS

1. IMPORTANT SAFETY INFORMATION.....	2
2. FCC INTERFERENCE STATEMENT.....	5
3. FEATURES.....	6
4. INSTALLATION.....	7
5. DOOR REMOVAL.....	9
6. DOOR HANDLE INSTALLATION.....	14
7. WATER SUPPLY CONNECTION.....	15
8. CONTROLS AND SETTINGS: EXTERNAL WATER DISPENSER MODEL.....	17
9. AUTOMATIC ICE AND WATER DISPENSER.....	20
10. ICE MAKER.....	22
11. STORAGE FEATURES.....	23
12. STORING FOOD AND SAVING ENERGY.....	26
13. NORMAL OPERATING SOUNDS.....	27
14. FILTER REPLACEMENT.....	28
15. CARE AND CLEANING.....	31
16. TROUBLESHOOTING.....	33
17. LIMITED WARRANTY.....	38
18. QUEBEC RIGHT TO REPAIR.....	39

# 1. IMPORTANT SAFETY INFORMATION

## 1.1 Keep a record for quick reference

Model number

.....

Serial number

.....

Purchase date

.....

## 1.2 Serial number location



### **WARNING!**

You must follow these guidelines to ensure that your appliance's safety mechanisms are operating correctly.

## 1.3 Safety definitions



This is the safety alert symbol. It is used to alert of potential personal injury hazards. Obey all safety messages that follow this symbol to avoid possible injury or death.

### **DANGER**

DANGER indicates an imminently hazardous situation which, if not avoided, will result in death or serious injury.

### **WARNING!**

WARNING indicates a potentially hazardous situation which, if not avoided, could result in death or serious injury.

### **CAUTION!**

CAUTION indicates a potentially hazardous situation which, if not avoided, may result in minor or moderate injury.

### **IMPORTANT**

IMPORTANT indicates installation, operation or maintenance information which is important but not hazard-related.

## 1.4 Child safety

This appliance is not intended for use by persons (including children) with reduced physical, sensory or mental capabilities, or lack of experience and knowledge, unless they have been given supervision or instruction concerning use of the appliance by a person responsible for their safety.

Destroy or recycle the carton, plastic bags, and any exterior wrapping material immediately after the appliance is unpacked. Children should never use these items to play. Cartons covered with rugs, bedspreads, plastic sheets or stretch wrap may become airtight chambers, and can quickly cause suffocation.

## 1.5 Important safety instructions

### **DANGER**



DANGER Risk of fire or explosion. Flammable refrigerant used. Do not use mechanical devices to defrost the appliance. Do not puncture refrigerant tubing.

DANGER Risk of fire or explosion. Flammable refrigerant used. To be repaired only by trained service personnel. Use only manufacturer-authorized service parts. Any repair equipment used must be designed for flammable refrigerants. Follow all manufacturer repair instructions. Do not puncture refrigerant tubing.

**⚠ CAUTION!**



CAUTION Risk of fire or explosion due to puncture of refrigerant tubing. Follow handling instructions carefully. Flammable refrigerant used.

This appliance is for storage only and should not be used for any other purpose.

Do not store or use gasoline or other flammable vapors and liquids in the vicinity of this or any other appliance.

Do not store explosive substances such as aerosol cans with a flammable propellant in this appliance.

Do not operate the appliance in the presence of explosive fumes. Avoid contact with any moving parts of automatic ice maker.

Remove all staples from the carton. Staples can cause severe cuts, and also destroy finishes if they come in contact with other appliances or furniture.

**⚠ WARNING!**

Do not use electrical appliances inside the food storage compartments of the appliance unless they are of the type recommended by the manufacturer.

**⚠ WARNING!**

CALIFORNIA RESIDENTS ONLY  
WARNING! Cancer and Reproductive Harm <http://www.P65Warnings.ca.gov>

## 1.6 Proper disposal of your appliance

**⚠ CAUTION!**



Risk of fire or explosion. Dispose of the appliance properly in accordance with the applicable federal or local regulations. Flammable refrigerant used.

### Risk of child entrapment

Child entrapment and suffocation are not problems of the past. Junked or abandoned appliances are still dangerous – even if they will sit for “just a few days”. If you are getting rid of your old appliance, follow the instructions below to help prevent accidents.

We strongly encourage responsible appliance recycling/disposal methods. Check with your utility company or visit <http://www.energystar.gov/recycle> for more information on recycling your old appliance.

### Before you throw away your old appliance:

- Remove doors.
- Leave shelves in place so children may not easily climb inside.
- Have it removed by a qualified service technician.

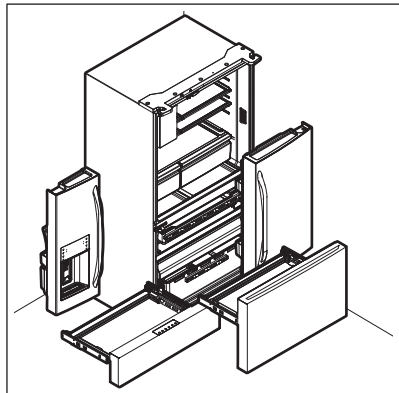

# 1.7 Electrical information

- The appliance must be plugged into its own dedicated 115 Volt, 60 Hz., 15 Amp, AC only electrical outlet. The power cord of the appliance is equipped with a three-prong grounding plug for your protection against electrical shock hazards. It must be plugged directly into a properly grounded three-prong receptacle. The receptacle must be installed in accordance with local codes and ordinances. Consult a qualified electrician. Do not use an extension cord or adapter plug.

**⚠ WARNING!**  
Avoid fire hazard or electric shock.

- If the power cord is damaged, it should be replaced by an authorized service technician to prevent any risk.
- Never unplug the appliance by pulling on the power cord. Always grip the plug firmly, and pull straight out from the receptacle to prevent damaging the power cord.
- Unplug the appliance before cleaning and before replacing the light bulb to avoid electrical shock.

- Performance may be affected if the voltage varies by 10% or more. Operating the appliance with insufficient power can damage the compressor. Such damage is not covered under your warranty.
- Do not plug the unit into an electrical outlet controlled by a wall switch or pull cord to prevent the appliance from being turned off accidentally.
- Do not pinch, knot, or bend the power cord in any manner.

**⚠ WARNING!**  
When positioning the appliance, ensure the supply cord is not trapped or damaged.  
Do not locate multiple portable socket-outlets or portable power supplies at the rear of the appliance.

**⚠ WARNING!**  
Do not, under any circumstances, cut, remove, or bypass the grounding prong (A). Always use the power cord with a three-prong grounded plug and grounding type wall receptacle.



## 2. FCC INTERFERENCE STATEMENT

This equipment has been tested and found to comply with the limits for a Class B digital device, pursuant to part 15 of the FCC Rules. These limits are designed to provide reasonable protection against harmful interference in a residential environment. This equipment generates, uses, and can radiate radio frequency energy and, if not installed and used in accordance with the instructions, may cause harmful interference to radio communications. However, there is no guarantee that interference will not occur in a particular installation. If this equipment does cause harmful interference to radio or television reception, which can be determined by turning the device off and on, the user is encouraged to try to correct the interference by one or more of the following measures:

- Reorient or relocate the receiving antenna.
- Increase the separation between the device and receiver.
- Connect the equipment into an outlet other than the one used for the receiver.
- Consult the dealer or an experienced radio/TV technician for assistance.

This device complies with Part 15 of the FCC Rules. Operation is subject to the following two conditions: (1) This device may not cause harmful interference, and (2) This device must accept any interference received, including interference that may cause undesired operation.

**FCC CAUTION:** Any changes or modifications not expressly approved by the party responsible for compliance could

void the user's authority to operate the equipment.

#### **Host Device Labeling**

This device includes the following module.  
Contains FCC ID: 2AIBX-NIULL

#### **RF Exposure Statement**

This equipment complies with FCC radiation exposure limits set forth for an uncontrolled environment. This equipment should be installed and operated with minimum 20 cm between the radiator and your body. This transmitter must not be collocated or operating in conjunction with any other antenna or transmitter unless authorized to do so by the FCC.

#### **Industry Canada (IC) Statement**

This Class B digital apparatus complies with Canadian ICES-003.

This device complies with Industry Canada license-exempt RSS standard(s). Operation is subject to the following two conditions: (1) this device may not cause interference, and (2) this device must accept any interference, including interference that may cause undesired operation of the device.

#### **RF Exposure**

The antenna (or antennas) must be installed so as to maintain at all times a distance minimum of at least 20 cm between the radiation source (antenna) and any individual. This device may not be installed or used in conjunction with any other antenna or transmitter.

#### **Host device Labeling**

This device includes the following module.  
Contains IC: 2AIBX-NIULL

Canada: 21700-NIULL

**Disclaimer:** The software in this product contains components that are based on free and open source software. Electrolux gratefully acknowledges the contributions of the open software and robotics communities to the development project. To access the source code of these free and open source software components whose license conditions require publishing, and to see their full copyright information and applicable license terms, visit: <http://electrolux.opensourcerepository.com> (folder NIU5).

## 3. FEATURES

### **IMPORTANT**

Features may vary by model.  
Accessories are available for your appliance and may be purchased at [Frigidaire.com](http://Frigidaire.com) or by calling toll-free 1-800-374-4432.

## 3.1 External Water Dispenser Model

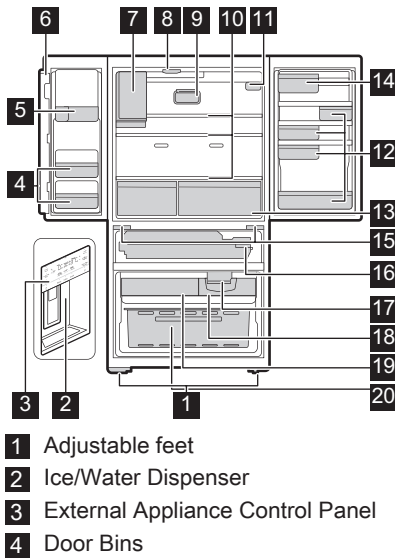

- 5 Ice Chute
- 6 Flipper Mullion
- 7 Ice Maker
- 8 Flipper Guide
- 9 Air Filter
- 10 Shelves
- 11 Water Filter
- 12 Door Bin
- 13 CrispSeal™ Fresh Crispers
- 14 Snack Zone
- 15 Adjustable Hinges
- 16 Custom-Flex™ Temp Drawer
- 17 Ice Maker
- 18 Ice Bin
- 19 Upper Freezer Basket
- 20 Lower Freezer Basket

## 4. INSTALLATION

This User Manual provides general installation and operating instructions for your model. We recommend using a service or kitchen contracting professional to install your appliance. Use the appliance only as instructed in this User Manual. Before starting the appliance, follow these important first steps.

### 4.1 ✓ Installation Checklist

#### Doors

- Handles are secure and tight

#### Leveling

- Cabinet is setting solid on all corners

#### Electrical Power

- House power is turned on
- Appliance is plugged in

#### Ice Maker

- House water supply is connected to the appliance



### **WARNING!**

Potable water supply only.

- No water leaks present in any connections - recheck in 24 hours
- Ice maker is turned on

#### Final Checks

- Shipping material is removed

- Registration card is sent in

### 4.2 Tools necessary

These tools are necessary at different stages of the installation process:

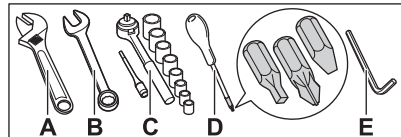

- A. Adjustable Wrench
- B. 3/8" Fixed Wrench
- C. 5/16" Socket Wrench
- D. Screwdriver: Phillips™ Head or Quadrex Head
- E. 6 mm Allen Wrench

### 4.3 Location

- If possible, place the appliance out of direct sunlight and away from the range, dishwasher, or other heat sources.
- The appliance must be installed on a floor that is level and strong enough to support a fully loaded appliance.

- Consider water supply availability for models equipped with an automatic ice maker.

### **⚠ WARNING!**

This appliance is intended for use in residential household and similar interior applications such as:

- Kitchen / kitchenette
- Pantry room
- Basement
- Enclosed garage
- Other interior residential type environments

### **⚠ WARNING!**

Allow the following clearances for ease of installation, proper air circulation, plumbing, and electrical connections:

- Top 3/8" (9.5 mm)
- Sides 3/8" (9.5 mm)
- Back 1" (25.4 mm)

## 4.4 Door opening

Position the appliance to allow easy access to a counter when removing food. Make sure the refrigerator drawers and freezer baskets can be fully open.

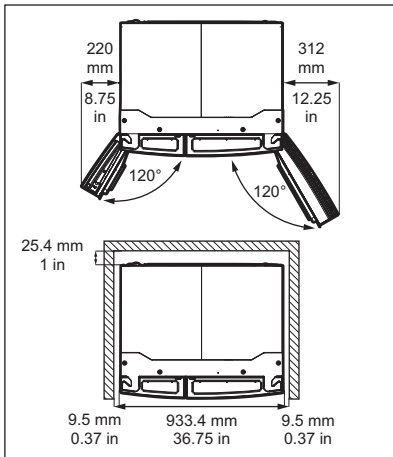

## 4.5 Cabinet leveling and door alignment

Guidelines for final positioning of appliance:

- All 4 corners of the cabinet must rest firmly on the floor.

- Slightly elevate the front to ensure that doors close and seal properly.
- Align the doors with each other and level them.

You can meet most of these conditions by raising or lowering the adjustable front feet.

## 4.6 Leveling

Level the cabinet by raising or lowering the front adjustable feet.

1. Slightly open the freezer drawer.
2. Lower the adjustable feet until they touch the floor. Use pliers to adjust.
  - To raise the unit, turn the feet clockwise.
  - To lower the unit, turn the feet counterclockwise.

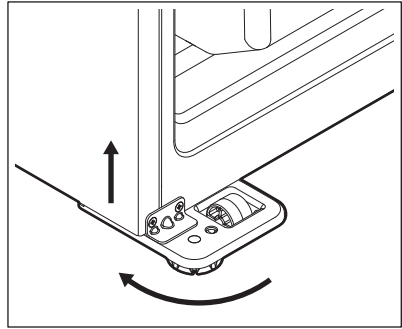

3. Ensure both doors are free of binding. The seals must touch the cabinet on all 4 sides.
4. Ensure the cabinet is stable.

## 4.7 Door leveling

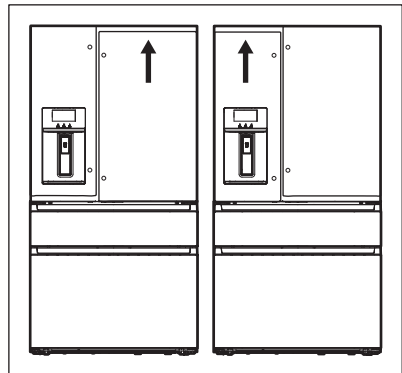

To adjust the door height:

1. Open the Custom-Flex™ Temp drawer to access the lower hinges.
2. Insert a 6 mm Allen wrench into the lower hinge shaft.
  - To lower the door, turn the adjustment screw clockwise.
  - To raise the door, turn the adjustment screw counterclockwise.

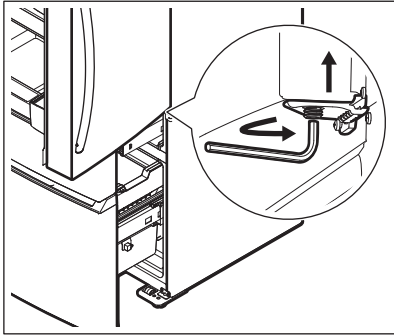

#### 4.8 Flipper mullion

Adjust the flipper mullion for proper connection with the mullion guide. Ensure

the flipper mullion is folded and perpendicular to the fresh food door. If the mullion guide is not in the correct position, it could prevent the door from closing completely.

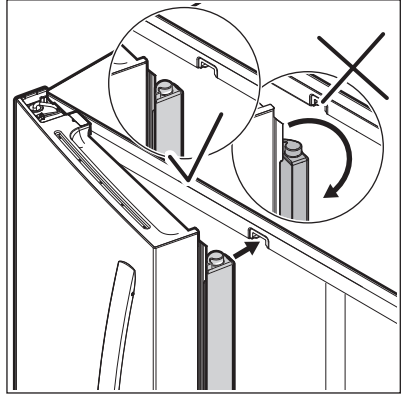

## 5. DOOR REMOVAL

### 5.1 Getting through narrow spaces

If your appliance does not fit through an entrance area, you can remove the doors. Check first by measuring the entrance.

### 5.2 Removing/Installing refrigerator doors

To prepare for removing the doors:

1. Unplug the electrical power cord from the wall outlet.
2. Remove any food from the door shelves and close the doors.



#### **WARNING!**

Make sure the electrical power cord is unplugged from the wall outlet.

To remove refrigerator doors:

1. Open doors to 90°.
2. Remove all 5 Phillips™ screws from top hinge cover and lift up.

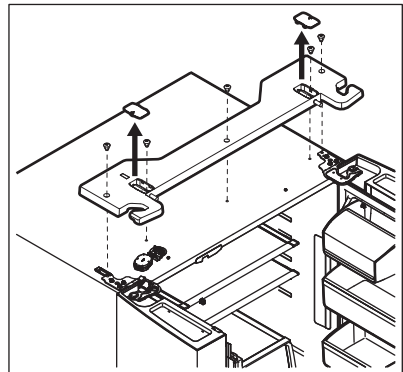

3. Trace lightly around the door top hinges with a pencil. This makes reinstallation easier.
4. Disconnect any electrical harnesses running from the doors to the hinge cover.

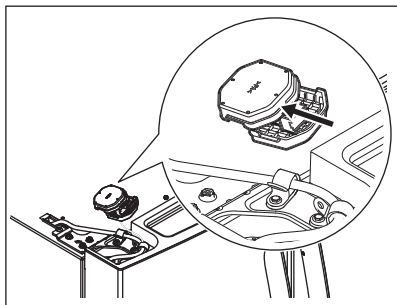

5. Pull up on the water line gently to remove it from the door.

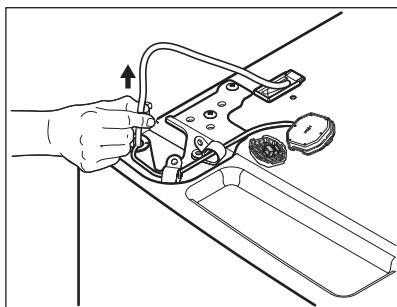

**NOTE**

Be careful while pulling the water tube from the door to be sure the tube does not kink.

**NOTE**

You will pull approximately 4ft of water tube from the refrigerator door.

**CAUTION!**

Make sure the doors are set aside in a secure position where they cannot fall and cause personal injury, or damage to the doors or handles.

6. Remove the three 8mm bolts from both top hinges. Lift the doors up off lower hinges and carefully set them aside.

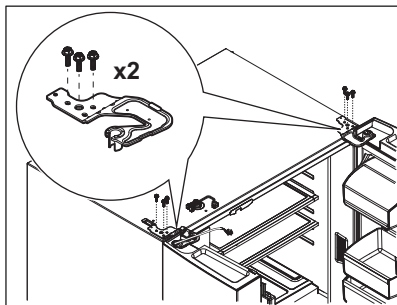

7. You may need to remove the lower hinges for clearance purposes. To gain access to the lower hinges, extend the Custom-Flex™ Temp Drawer. Unscrew the 3 lower hinge screws and slide the hinge inward.

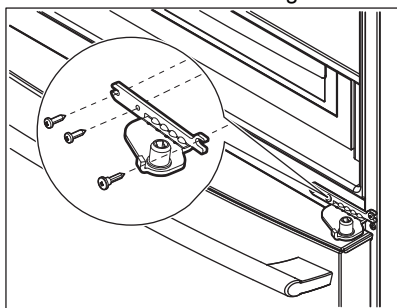

8. To reinstall the doors, reverse the procedure.

**IMPORTANT**

Make sure the water line tubing goes through the hole at the top of the dispenser pocket. A metal wrap on the tubing prevents damage from the hinge rubbing against it. Fix the back around the tube in the proper location upon reinstallation to protect the tube from the hinge.

## External dispenser model

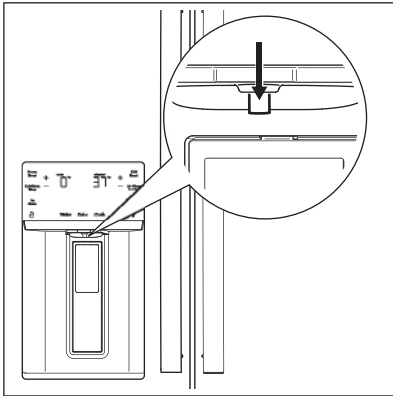

### NOTE

When reinserting the water tube and replacing the top hinge cover, ensure the tube does not kink.

Once both doors are in place, ensure they are aligned with each other and level. Refer to Installation. Replace the top hinge cover.

## 5.3 Door opening angle feature

If your refrigerator doors are touching objects located close to the side of the appliance, the doorstop can be replaced with the provided optional door opening angle feature, to reduce the maximum door opening angle.

### NOTE

Optional door opening angle feature parts are identified:  
LH - Left Hand, to apply on left door.  
RH - Right Hand, to apply on right door.

## Optional Door Opening Angle Feature

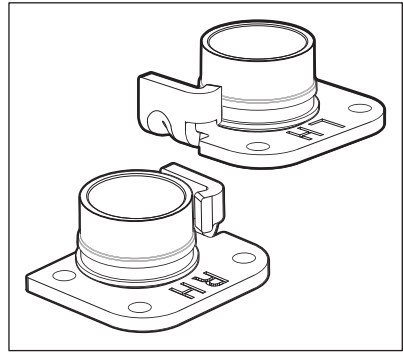

## Default Door Stop

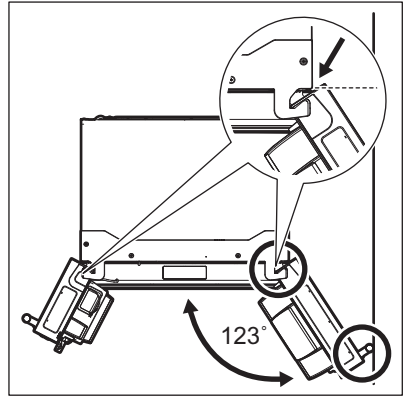

## Optional Door Stop Feature

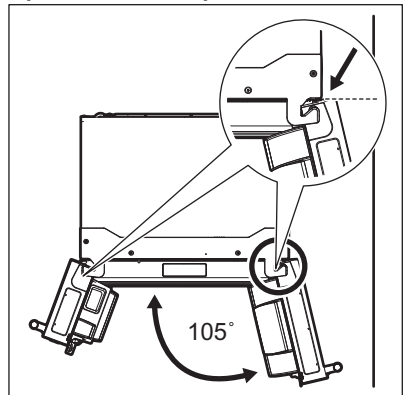

To remove and replace the door stop:

1. Remove the doors. Refer to Door Removal.
2. Turn the doors upside down to access the door stop located in the hinge area of the door.

## Door Stopper Removal

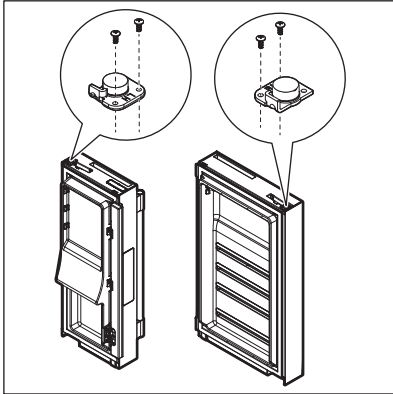

3. Remove the 2 screws from the door stop.
4. Replace the door stop with optional door opening angle feature. Reinsert the 2 screws.
5. Repeat the process for the opposite refrigerator door.
6. Reinstall the doors to the cabinet.

## 5.4 Custom-Flex™ Temp Drawer

To remove the Custom-Flex™ Temp Drawer:

1. Fully open the drawer.
2. Remove the basket from the drawer.

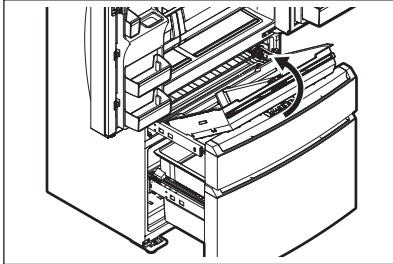

3. For some models only: Unsnap the 4 cable ties by pressing clip sides together and pushing them through the opening.

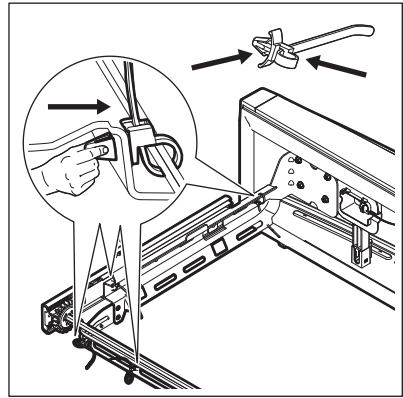

4. For some models only: Remove the screw and the retaining clip and disconnect the harness.

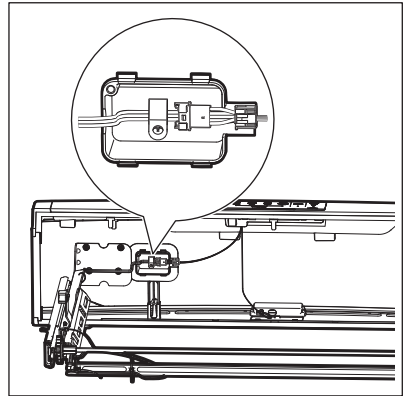

5. To fully remove the drawer from the cabinet, press the tabs on both sides, and slide the rails past the clips on both sides.

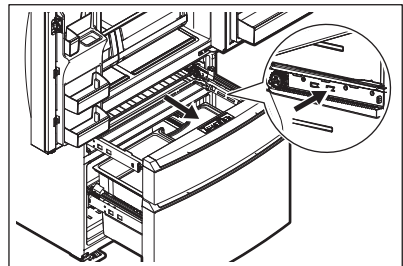

To reinstall the Custom-Flex™ Temp Drawer:

1. Place the drawer with the brackets and sliders inside the compartment, and

click the sliders into place on each side.

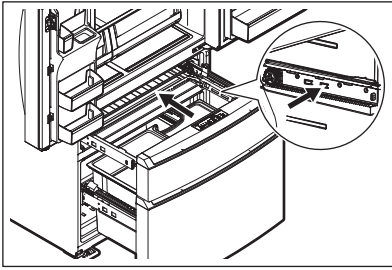

2. For some models only: Reconnect the cabinet harness.
3. For some models only: Replace the retaining clip and secure it with the screw.

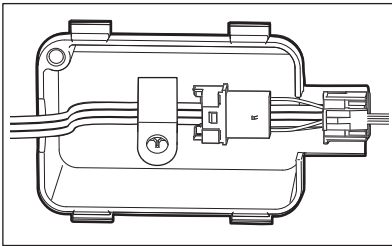

4. For some models only: Reattach the electrical harness by positioning the cable clips over the black markings on the harness. Push the 4 cable clips through the openings in the rail to secure the harness in place.

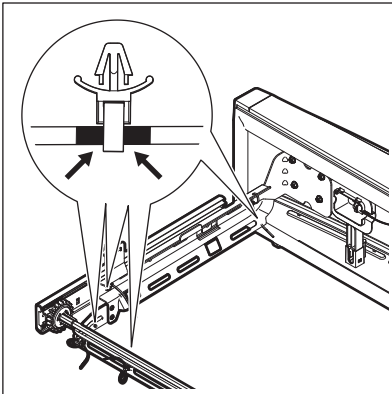

5. Slide the basket into place.
6. Close the drawer.

### **⚠ CAUTION!**

The drawer is heavy. Use caution when lifting.

## 5.5 Removing The Freezer Drawer

To remove the freezer drawer:

1. Open the drawer and fully extend it.
2. Remove the upper freezer drawer.
3. Remove the lower freezer basket.
4. Inside the cabinet, press the tab on both sides to release the sliders.
5. Remove the drawer with brackets and sliders.

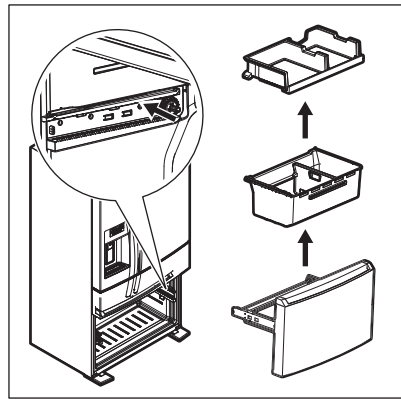

To reinstall the freezer drawer:

1. Place the drawer with brackets and sliders inside the cabinet and click into place.
2. Replace the lower freezer basket first, and then the upper freezer basket. Ensure the upper freezer basket rollers are seated correctly into the tracks before closing the freezer drawer.



For additional instructions, refer to Storage Features

## 6. DOOR HANDLE INSTALLATION

### CAUTION!

Wear gloves and safety goggles. Use extreme caution when installing these handles.

The rounded end of the handles may be sharp (some models).

### 6.1 Door handle installation

To install the door handle:

1. Remove the handles and any other protective packaging from the carton.
2. Position the handle end caps over upper and lower preinstalled shoulder bolts (A) that are fastened into door, ensuring the holes for the set screws are facing towards the opposite door.
3. While holding handle firmly against door, fasten upper and lower Allen set screws (B) with supplied Allen wrench.
4. Repeat the steps above to install the opposite handle. Ensure the holes for the set screws are facing towards the opposite door.

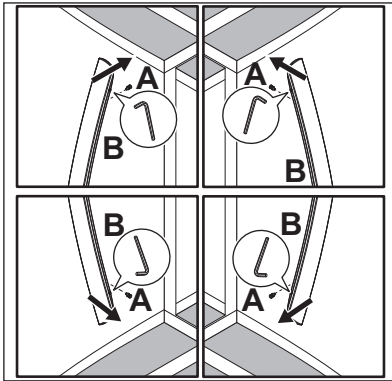

### NOTE

When tightening the Allen set screws, apply force to the longer arm of the Allen wrench supplied in the handle packaging.

### NOTE

Tighten and sub-flush all set screws (place the Allen set screw just below the surface of the end cap) of the handle end cap. Draw the end caps tight to the freezer and refrigerator doors with no gaps. To avoid scratching the metal door, keep the door open while torquing down the set screws.

The door handle may loosen over time. If this happens, tighten the set screws on the handles.

## 7. WATER SUPPLY CONNECTION

### 7.1 Before Installing The Water Supply Line

#### **⚠ WARNING!**

To avoid electric shock, which can cause death or severe personal injury, disconnect the appliance from the electrical power before connecting a water supply line to the appliance.

#### **⚠ CAUTION!**

To avoid property damage:

- Use copper or stainless steel braided tubing for the water supply line. Do not use water supply tubing made of 1/4" plastic. Plastic tubing greatly increases the potential for water leaks, and the manufacturer will not be responsible for any damage if you use plastic tubing for the supply line.
- Do not install water supply tubing in areas where temperatures fall below freezing.
- Chemicals from a malfunctioning softener can damage the ice maker. If the ice maker is connected to soft water, ensure that the softener is maintained and working properly.

#### **📌 IMPORTANT**

Ensure your water supply line connections comply with all local plumbing codes.

### 7.2 You will need

- Basic tools: adjustable wrench, flat-blade screwdriver, and Phillips™ screwdriver.
- Access to a household cold water line with water pressure between 30 and 100 psi.
- A water supply line made of 1/4" (6.4 mm) OD, copper or stainless steel tubing. To determine the length of tubing needed, measure the distance from the ice maker inlet valve at the back of the appliance to your cold water pipe. Then add approximately 6 ft

(1.8 m) to ensure you can move the appliance for cleaning.

- A shutoff valve to connect the water supply line to your household water system. Do not use a self-piercing type shutoff valve.
- Do not reuse compression fitting or use thread seal tape.
- A compression nut and ferrule (sleeve) for connecting a copper water supply line to the ice maker inlet valve.

#### **📌 NOTE**

Check with your local building authority for recommendations on water lines and associated materials prior to installing your new refrigerator. Depending on your local/state building codes, Frigidaire recommends:

- for homes with existing valves its Smart Choice® water line kit 5304437642 with a 6 ft stainless steel water line.

Please refer to Frigidaire.com for more information.

### 7.3 Installing the Water Supply Line

#### **📌 IMPORTANT**

Your appliance water supply system includes several tubing lines, a water filter, and a water valve. To ensure that your water dispenser works properly, this system must be completely filled with water when your appliance is first connected to the household water supply line.

#### Connection to household water supply with 1/4" compression fitting

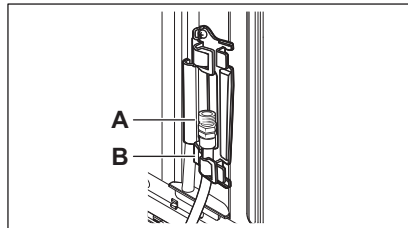

- A. Water inlet fitting
- B. Plastic tubing to water valve

**6 ft (1.8 meters) Stainless Steel water line from household water supply line**

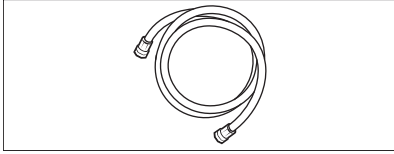

**Water inlet brass fitting**

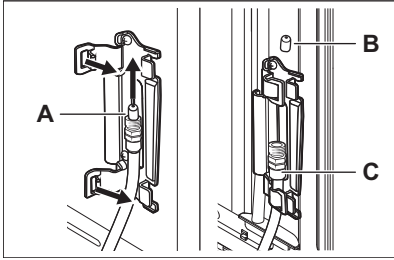

- A. Plastic cap
- B. Remove plastic cap from water inlet fitting
- C. 1/4" plastic tube to water valve

To connect water tube to household water supply:

1. Disconnect refrigerator from electric power source.
2. Place end of water supply line into sink or bucket. Turn on water supply and flush supply line until water is clear. Turn off water supply at shutoff valve.

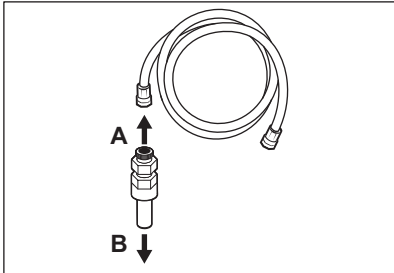

- A. To household water supply
  - B. To unit water valve
3. Open the locking clips and grab the water line coming from the refrigerator.

Remove the plastic cap from the water inlet fitting and discard the cap.

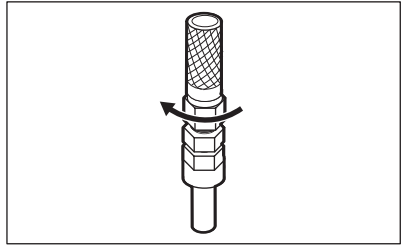

4. If using (recommended) stainless steel braided tubing - the nut and the ferrule are already assembled on the tubing. Slide the compression nut onto the water inlet fitting and finger tighten.
5. Using two 1/2" wrenches, one to hold the household water line nut (A) and the other to hold the water inlet fitting nut (B), tighten a half turn with the wrench (A). Do not over tighten.

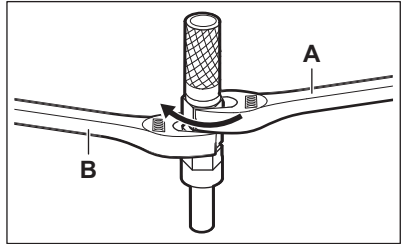

6. Replace the connected tubes into the clips and lock the clips back in place to keep the tubing in the right position.
7. Turn on water supply at shutoff valve and tighten any connections that leak.
8. Reconnect refrigerator to electrical power source.
9. Turn the ice maker on.
10. Purge air from the Ice and Water Dispenser System by operating the water dispenser for 3 - 4 minutes. This requires dispensing several glasses of water.

## 8. CONTROLS AND SETTINGS: EXTERNAL WATER DISPENSER MODEL

### Control display

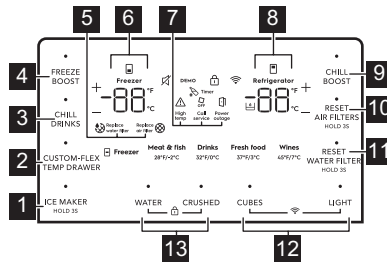

<b>1</b>	Ice Maker button	Press and hold for 3 seconds to turn the ice maker on/off.
<b>2</b>	Custom-Flex Temp Drawer button	Press the button to adjust the temperature.
<b>3</b>	Chill Drinks button	Press the button to quickly chill a drink inside the freezer compartment. A time value appears on the freezer temperature display (in minutes). Set the timer using the + / - buttons. The range is from 20 to 45 minutes in 5 minute intervals. A tone sounds when you input the time. Drinks may freeze if the temperature is too low or timer setting is too long.
<b>4</b>	Freeze Boost	Prior to grocery shopping, activate Freeze Boost to lower the temperature and freeze food faster. Freeze Boost stays active for up to 24 hours before automatic deactivation. You can turn it off manually by pressing Freeze Boost. This restores the freezer to the previous temperature setting.
<b>5</b>	Water filter/Air filter replacement indicators	Replace the filter when the indicator illuminates
<b>6</b>	Freezer control	Press either the + or - to adjust the temperature. The temperatures range from -6°F (-21°C) to 6°F (-15°C).
<b>7</b>	Alarms indicators	In case of alarm, the indicators lights up, and a tone sounds. Press any button to silence the tone.
<b>8</b>	Refrigerator control	Press either the + or - to adjust the temperature. The temperatures range from 34°F (1°C) to 44°F (7°C).
<b>9</b>	°F/°C	To toggle between Fahrenheit (°F) and Celsius (°C), simultaneously press and hold + and – for 5 seconds.
<b>10</b>	Chill Boost	Prior to grocery shopping, activate Chill Boost to lower the temperature and cool food faster. Chill Boost stays active for up to 6 hours.
<b>11</b>	Reset Air Filter	Press and hold the button for 3 seconds to reset after changing the filter.
<b>12</b>	Reset Water Filter	Press and hold the button for 3 seconds to reset after changing the filter.
<b>13</b>	Cubes/Light	Press Cubes to dispense cubed ice. Press Light to switch the dispenser light on and off. Press and hold Cubes and Light simultaneously until the tone sounds and the wi-fi indicator starts to blink.

#### 14 Water/Crushed

Press Water to dispense water.  
Press Crushed to dispense crushed ice.  
Press Water and Crushed simultaneously for 3 seconds to enable/disable the lock function. The lock function disables the access to the display and to the ice and water dispenser. The indicator flashes and a sound alarm sounds.

### Display modes

- **Sleep mode**  
As a default, the display goes to sleep after a short time. If you press any icon, the display awakens. After a short time, it goes back to sleep. When in sleep mode, wake up the appliance control display to confirm the ice maker is on/off. You can turn sleep mode off to have the display on full time (awake mode). When sleep mode is off, the display is always illuminated. To turn sleep mode on/off, simultaneously press and hold Ice and Light for 5 seconds. A tone confirms.
- **Awake Mode**  
To change from sleep mode to awake mode, simultaneously press and hold Ice and Light for 5 seconds. The display shows the current temperature/ice maker status. A tone confirms.

### Custom-Flex Temp Drawer

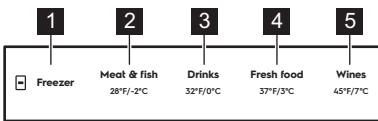

Press the Custom Flex Temp Drawer button on the control panel display to adjust the temperature. A tone sounds to confirm the choice.

- 1 Freezer**  
To change the drawer temperature use the control panel display. Changing the temperature on the display changes the temperature both in the drawer and in the freezer compartment.
- 2 Meat&fish**  
This function sets the drawer temperature to 28°F (-2°C).
- 3 Drinks**  
This function sets the drawer temperature to 32°F (0°C).
- 4 Fresh food**  
This function sets the drawer temperature to 37°F (3°C).

#### 5 Wines

This function sets the drawer temperature to 45°F (7°C).

### 8.1 Clear Alerts

#### High Temp

The alarm sounds in the event of a high temperature condition. The indicator illuminated and the appliance control panel displays HI for whichever compartment the alarm is detected in. The alarm sounds every 10 seconds until acknowledged. Touch any key or open a door to silence the alarm.

#### Power Outage

In the event of a power outage, a tone sounds and the power outage indicator illuminates once power has been restored. Press any key on the appliance control display to silence the alarm.

#### Call Service

Indicates that the appliance has detected an issue that requires professional attention. When this alarm appears on the control panel, the appliance may continue to operate, but some functions could be limited or unavailable.

### 8.2 Connecting the appliance to the internet

Requirements:

- This app requires the latest OS on your smartphone. Refer to Frigidaire.com for compatibility information.
- A secure password-protected 2.4GHz internet connection on a WPA/WPA2 compliant network.
- Valid email address and password.
- A Wi-Fi router that supports IEEE 802.11 b/g/n.
- When setting up your connection, make sure you are in front of the appliance.

To connect the appliance to the home internet:

1. Download the app.



2. When prompted to "Turn on appliance network," press and hold the Cubes and Light buttons on the control panel simultaneously for 5 seconds. Once the network is activated, 'AP' appears on the control panel display. The appliance is now ready to join the home network.
3. Follow the instructions in the app to complete the process.
4. Confirm the appliance is visible in the app.
5. Send a command from the app to the appliance. The app should update to show the new settings, and the appliance should respond to the command.

For connectivity-related assistance, call 1-800-311-4667 Monday - Friday, 9:00 am - 6:00 pm EST or email [SmartHelp.US@Frigidaire.com](mailto:SmartHelp.US@Frigidaire.com). Find the frequently asked questions on [Frigidaire.com](http://Frigidaire.com).

### 8.3 Sabbath Mode

#### NOTE

While in Sabbath Mode, neither the lights, dispenser, nor the control panel will work until Sabbath Mode is deactivated. Refrigerator stays in Sabbath Mode after power failure recovery. It must be deactivated with the buttons on the control panel.

#### NOTE

Although you have entered the Sabbath Mode, the ice maker will complete the cycle it had already initiated. The ice cube compartment will remain cold and new ice cubes can be made with standard trays.

The Sabbath Mode is a feature that disables portions of the refrigerator and its controls in accordance with observance of

the weekly Sabbath and religious holidays within the Orthodox Jewish community.

Sabbath Mode is turned on and off by simultaneously pressing and holding both the FZ- and FF+ for 10 seconds. The display shows Sb while in Sabbath mode.

In the Sabbath Mode, the High Temp alarm is active for health reasons. For example, if the door is left ajar the High Temp alarm is activated. The refrigerator will function normally once the door is closed, without any violation of the Sabbath/Holidays. The High Temp alarm is permitted when cabinet temperature is outside the safe zone for 20 minutes. The alarm silences itself after 10 minutes while the High Temp icon stays lit until the Sabbath mode is exited.



For further assistance, guidelines for proper usage and a complete list of models with the Sabbath feature, visit the web at [star-k.org](http://star-k.org).

### 8.4 Setting cooling temperatures (options may vary)

#### NOTE

The recommended settings for a product installed in a kitchen is 37°F for the fresh food compartment and 0°F for the freezer.

#### IMPORTANT

If your product has food freezing in the fresh food compartment, increase the temperature setting 1 or 2°.

#### IMPORTANT

If you place food within 1" in front of the air ports, there may be the chance of freezing food.

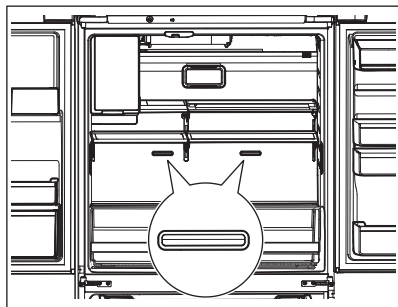

## 9. AUTOMATIC ICE AND WATER DISPENSER

### NOTE

Refrigerator Ice Maker (External Dispenser Models Only)

### 9.1 Priming the water supply system

Before making ice for the first time, prime the water supply system. Air in new plumbing lines can result in two or three empty ice maker cycles. If the system is not flushed, the first ice cubes may have discolored water or have an odd flavor.

Purge air from the system:

1. Press and hold a drinking glass against the water dispenser paddle until water comes out (it may take up to 4 minutes to purge air from the system).
2. Run approximately 1 full gallon of water through the dispenser before use, and discard.

**Dispenser (varies by model)**

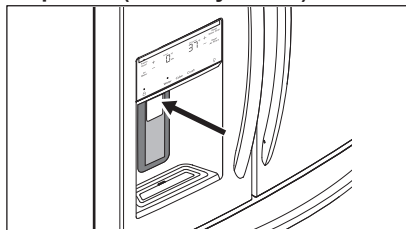

### CAUTION!

For proper dispenser operation, the recommended water supply pressure should fall between 30 psi and 100 psi. Excessive pressure may cause the system to malfunction.

### NOTE

The water dispenser has a built-in device that shuts off the water flow after 2 minutes of continuous use. To reset this shutoff device, release the dispenser paddle.

### NOTE

Dispensed water is not chilled. For colder water, add ice to cup or container before dispensing water.

### 9.2 Ice maker Operation and Care

After you properly install the refrigerator and it has cooled for several hours, the ice maker can produce ice within 24 hours.

### 9.3 Storage bin capacity

The refrigerator ice maker should produce:

- In a standard depth model: 3.2 to 3.7 lbs of ice per 24 hours.
- In a counter depth model: 3.2 to 3.7 lbs of ice per 24 hours.

The refrigerator ice bin holds around:

- In a standard depth model: 5 lbs of ice.

- In a counter depth model: 4 lbs of ice.

## 9.4 Turning the ice maker on/off

Ice production is controlled by the ice maker On/Off feature on the appliance control display. Press the On/Off feature to turn the ice maker on and off.

### **IMPORTANT**

Turning off the ice maker disables ice making. You will still be able to dispense existing ice, and dispense water.

### **NOTE**

The ice maker also has a built-in plastic signal arm that automatically stops ice production when the ice bin is full. This signal arm should not be used to manually stop the ice maker.

### **IMPORTANT**

Your ice maker is turned on at the factory so it can work as soon as you install your refrigerator. If you cannot connect a water supply, set the ice maker On/Off feature to Off; otherwise, the ice maker fill valve may make a loud chattering noise when it attempts to operate without water.

### **IMPORTANT**

On occasion, you may notice unusually small ice cubes in the bucket or in dispensed ice. This could occur in normal operation of the ice maker. If you start seeing these more frequently, it may be an indication of low water pressure or the water filter needs to be replaced. As the water filter nears the end of its useful life and becomes clogged with particles, less water is delivered to the ice maker during each cycle. If it has been 6 months or longer since you last changed your water filter, replace the water filter with a new one. Poor quality household water may require the filter to be changed more frequently.

## 9.5 Ice maker/Dispenser Tips

- Ice cubes stored too long may develop an odd flavor. Empty the ice container

as explained in Cleaning the ice maker section.

- If your refrigerator is not connected to a water supply or the water supply is turned off, turn off the ice maker.
- If you need a large quantity of ice at one time, it is best to get cubes directly from the ice container.
- The following sounds are normal when the ice maker is operating:
  - Motor running
  - Ice dropping into ice container
  - Water valve opening or closing
  - Running water



When dispensing ice, hold the cup in position for a moment after releasing the paddle. This ensures all ice falls into the cup.

### **CAUTION!**

Chemicals from a malfunctioning water softener can damage the ice maker. If the water supply to your refrigerator is softened, be sure the softener is maintained to work properly.

## 9.6 Cleaning the Ice Maker Bin

Clean the ice maker and ice bin at regular intervals, especially prior to vacation or moving.

1. Turn off the ice maker.
2. Remove the ice bin. Lift the ice bin upward, and then pull it straight out.

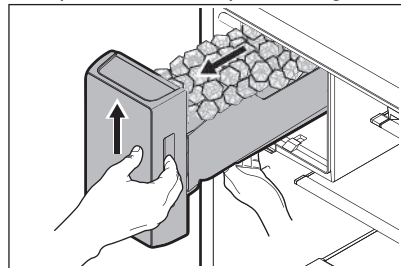

3. Empty the ice bin.

### **CAUTION!**

Never use an ice pick or similar sharp instrument to break up the ice. This could damage the ice bin. To loosen stuck ice, use warm water.

4. Clean the ice bin with mild detergent. Do not use harsh or abrasive cleaners. Rinse with clean water.
5. Let the ice bin dry completely before you put it back in the freezer.
6. Replace the ice bin.
7. Turn the ice maker on.

If there is a power failure for one hour or longer, the ice cubes in the ice bin may melt and re-freeze together. Remove and empty the ice bin if this happens.

### 9.7 When to remove and empty the ice bin

Remove and empty the ice bin if:

- An extended power failure (one hour or longer) causes ice cubes in the ice bin to melt and re-freeze together after power is restored, jamming the dispenser mechanism.
- You do not use the ice dispenser frequently. Ice cubes will freeze together in the bin, jamming the dispenser mechanism.

Refer to Cleaning the Ice Maker Bin.

## 10. ICE MAKER

### 10.1 Ice maker operation and care

After you properly install the appliance, the ice maker can produce ice within 24 hours. When using the ice maker for the first time, and in order for it to work properly, you need to clear air from the water tubing and the filter. If you do not flush the system, the first ice cubes may be discolored or have an odd flavor. Once the ice maker begins making ice, allow the bin to fill completely, and then discard the first full bin of ice.

### 10.2 Storage Bin Capacity

This ice maker should produce between 2 and 2.5 lbs of ice per 24 hours depending on use.

The ice bin should hold:

- For a standard depth appliance: around 7.5 lbs of ice.
- For a counter depth appliance: around 4.5 lbs of ice.

#### NOTE

The ice maker only produces the specified rate if you set the temperature to 0°F.

#### NOTE

The freezer ice maker fills the ice bin more in one spot. Move the ice to the edges of the bin to allow it to fill completely.

### 10.3 Turning the Ice Maker On/Off

Press or slide the power button to turn the ice maker on/off. The button and LED illuminate when active.

varies by model

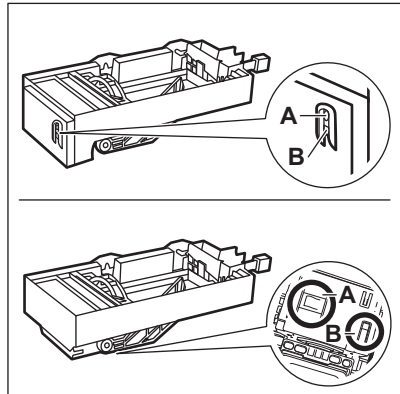

(A - power button, B - test button)

The ice maker regulates the ice production. It stops making ice when full and resumes when ice is low in the ice bin.

#### Remove the Ice Bin if:

An extended power failure (1 hour or longer) cause ice cubes in the ice bin to melt and re-freeze together after power is restored.

To remove ice bin lift it upward and pull straight out. Shake to loosen the cubes or clean.

## **⚠ CAUTION!**

Never use an ice pick or similar sharp instrument to loosen the ice cubes. This could damage the ice bin. To loosen ice clumps, use warm water. Before replacing the ice bin, ensure it is completely dry.

### **10.4 Ice maker tips**

The following sounds are normal when the ice maker is operating:

- Motor running

- Ice dropping into ice bin
- Water valve opening or closing
- Running water

Ice cubes stored too long may develop an odd flavor. Empty the ice bin as explained below.

## **⚠ CAUTION!**

If the water supply to your refrigerator is softened, properly maintain be sure the softener. Chemicals from a water softener can damage the ice maker.

## **11. STORAGE FEATURES**

### **11.1 Shelves**

## **⚠ CAUTION!**

To avoid personal injury or property damage, handle tempered glass shelves carefully. Shelves may break suddenly if nicked, scratched, or exposed to sudden temperature change. Allow the glass shelves to stabilize to room temperature before cleaning. Do not wash in dishwasher.

You can easily adjust shelf positions in the refrigerator compartments to suit your needs. The shelves have mounting brackets that attach to slotted supports at the rear of each compartment.

1. Remove all the food from the shelf.
2. Lift the front edge up and pull the shelf out.

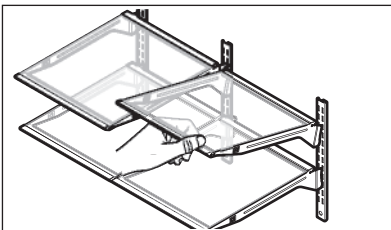

3. Replace by inserting the mounting bracket hooks into the desired support slots.
4. Lower the shelf and lock into position.

### **11.2 Slide-Under Shelf**

For some models only.

To adjust the slide-under shelf, push the front half of the shelf backward toward the rear of the cabinet until the rear half shelf drops down. Then, gently continue pushing the front half shelf back so it slides under the rear half shelf.

### **11.3 Flip Shelf**

To adjust the flip shelf:

1. Remove food from the shelf.
2. Lift the right edge of the shelf upwards.
3. Push the shelf to the left towards the ice maker.

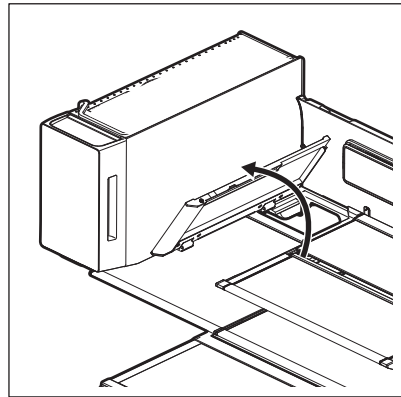

### **11.4 Drawers**

This appliance includes a variety of storage drawers.

### **11.5 CrispSeal® Fresh Crisper**

For some models only.

Use the crisper to keep produce fresh for longer.

Flip the crisper to use it as an open compartment for items such as beverages, yogurts, or snacks.

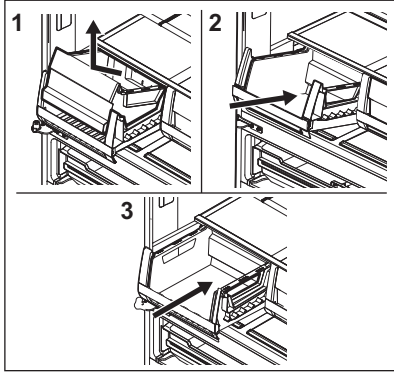
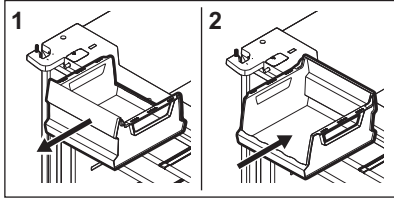

To remove the crisper:

1. Pull the drawer out until it stops.
2. Lift the front slightly.
3. Remove the drawer.

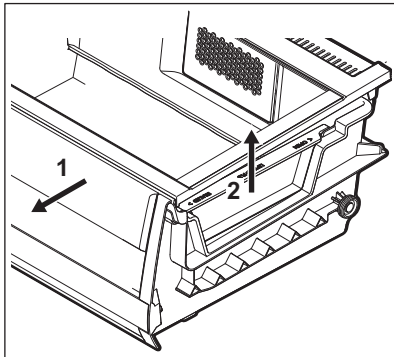

Remove the crisper insert and the PureAir Produce Keeper Plus™ filter before washing the crisper.

## 11.6 Auto-humidity Control Removal

To remove the auto humidity control membrane for cleaning:

1. Reach to the back of the humidity control cover.
2. Place your fingers between the humidity control and the back wall. Pull up on the cover.
3. Pull the cover toward the front of the cabinet and remove it.

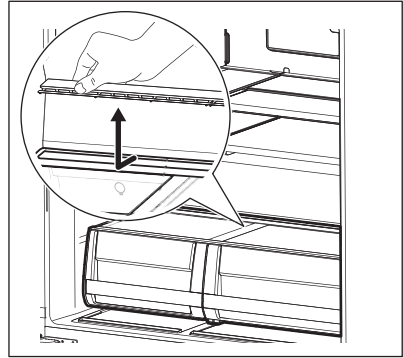

4. Remove the humidity membrane from the housing by lifting it up and sliding it over.

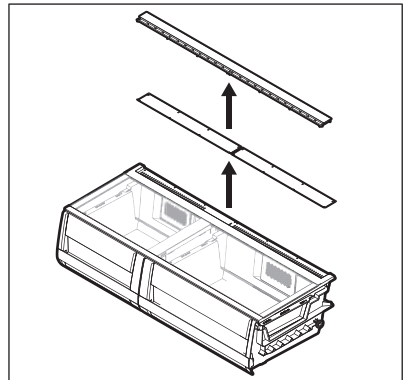

5. Clean the humidity membrane with hot, soapy water.
6. Replace the membrane in the housing by reversing the steps above.



We do not recommend replacing the auto-humidity membrane unless it becomes damaged or ruined. If the membrane becomes soiled, you can wash it with soap and water. Ensure the membrane is dry before replacing it in the housing.

### 11.7 SnackZone - Recessed Snack Drawer

These drawers are ideal for storing deli meats and cheeses.

Slide back the cover to access the drawers.

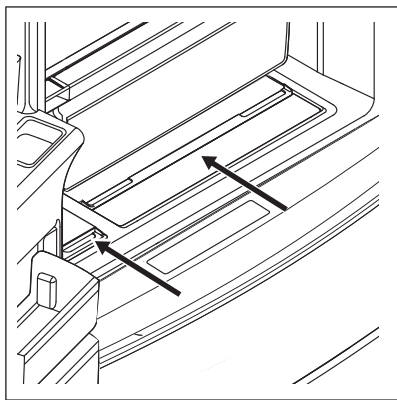

### 11.8 Custom-Flex™ Temp Drawer

(some models)

#### NOTE

Do not use the Custom-Flex™ Temp Drawer to store fresh produce. These items may freeze and cause damage to fruits and leafy vegetables.

The drawer locks automatically to prevent unwanted use. To unlock, press and hold the Unlock button for 3 seconds. The drawer locks again after 10 seconds without interaction.



Do not store glass bottles in the Custom-Flex™ Temp Drawer when the temperature setting is in Freezer or Cold Drinks modes. The glass may break and shatter, causing physical harm and injury.

### 11.9 Custom-Flex™ Temp Drawer Divider

For some models only.

To position drawer dividers, slide them left or right. Dividers do not lock but use the weight of stored items to stay in place. Dividers may shift when opening or closing the drawer if fewer items are stored.

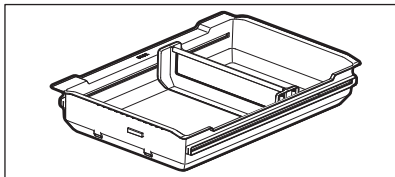

### 11.10 Doors

#### Storage bins (varies by model)

The doors to your refrigerator compartment use a system of modular storage bins. All of these bins are removable for easy cleaning. Some of them have fixed positions, while others can be adjusted to your needs.

Door bins are ideal for storing jars, bottles, cans, and large drink containers. They also enable quick selection of frequently used items.

#### 11.11 Changing position of adjustable door bin

To change the position of an adjustable door bin:

1. Remove all food from door bin.
2. Grip the bin firmly with both hands and lift it upward.
3. Remove the bin.
4. Place the bin just above desired position.
5. Lower the bin onto supports until it is locked in place.
6. Place the bin liner into the bin.

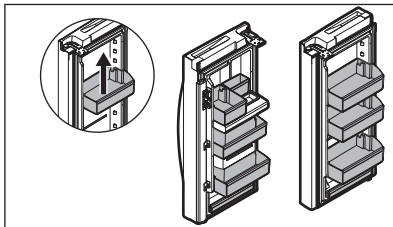

## 11.12 Removing/Installing Upper Freezer Drawer

To remove the upper freezer drawer:

1. Open the freezer compartment fully.
2. Lift the upper freezer drawer up and out.

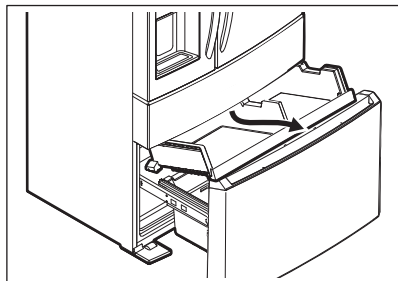

Reverse these steps to reinstall the drawer.

### IMPORTANT

There are wheels on the bottom of the drawer. Make sure all wheels are aligned with their tracks for proper function. If the drawer is not aligned, it will cause problems with the door operation.

### NOTE

If the basket does not rest on the stabilizer bar retainer clips, the drawer does not close correctly.

## 11.13 Freezer accessories

Your freezer has baskets and dividers you can adjust to your needs.

## 11.14 Lower basket divider

To reposition the lower basket divider, grab the lower divider and slightly pull it up to slide the divider to the next position.

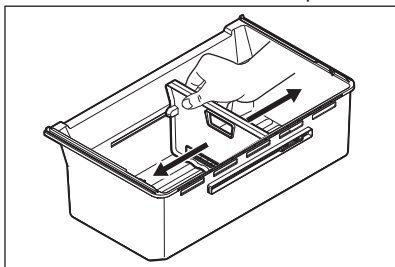

You cannot remove the divider.

## 11.15 Removing/Installing Freezer Basket

To remove the freezer basket:

1. Open the freezer compartment completely.
2. Lift the basket up and remove it.

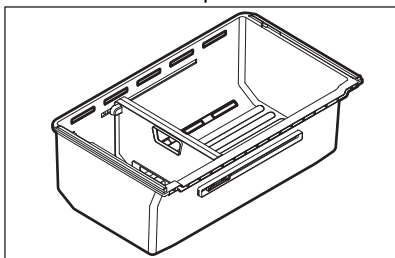

Reverse the steps to reinstall the freezer basket.

## 12. STORING FOOD AND SAVING ENERGY

### 12.1 Ideas for storing food

#### Fresh food storage

- Keep the fresh food compartment between 34°F and 40°F, with an optimum temperature of 37°F.
- Avoid overcrowding the refrigerator shelves, which reduces air circulation and causes uneven cooling.
- Avoid placing food in front of air ports.

#### Fruits and vegetables

- Store fruits and vegetables in crisper drawers, where trapped moisture helps

preserve food quality for longer time periods.

- Wash items and remove excess water.
- Wrap any items that have strong odors or high moisture content.

#### Meat

- Wrap raw meat and poultry separately and securely to prevent leaks and contamination of other foods or surfaces.
- Use the deli drawer to store meat/poultry for short-term storage. Any

meat to be kept longer than two days should be frozen.

### Frozen foods storage

- Keep the freezer compartment at 0°F or lower.
- A freezer operates most efficiently when it is at least 2/3 full.

### Packaging foods for freezing

- To minimize food dehydration and quality deterioration, use aluminum foil, freezer wrap, freezer bags, or airtight containers. Force as much air out of the packages as possible and seal them tightly. Trapped air can cause food to dry out, change color, and develop an off-flavor (freezer burn).
- Wrap fresh meats and poultry with suitable freezer wrap prior to freezing.
- Do not refreeze meat that has completely thawed.

### Loading the freezer

- Prior to grocery shopping, activate Freeze Boost so that on your return you can ensure your newly purchased food designated for the freezer will be preserved as quickly as possible.
- Activating Freeze Boost also will help your freezer more efficiently maintain the selected temperature after placing new purchases with pre-existing frozen foods.
- Avoid adding too much warm food to the freezer at one time. This overloads the freezer, slows the rate of freezing, and can raise the temperature of frozen foods.
- Leave a space between packages, so cold air can circulate freely, allowing food to freeze as quickly as possible.

## 12.2 Ideas for energy saving

### Installation

- Locate the refrigerator in the coolest part of the room, out of direct sunlight, and away from heating ducts or registers.
- Do not place the refrigerator next to heat-producing appliances such as a range, oven, or dishwasher. If this is not possible, a section of cabinetry or an added layer of insulation between the two appliances will help the refrigerator operate more efficiently.
- Level the refrigerator so that the doors close tightly.

### Temperature setting

- Refer to Controls and Settings for procedures on temperature settings.

### Food storage

- Avoid overcrowding the refrigerator or blocking cold air vents. Doing so causes the refrigerator to run longer and use more energy.
- Cover foods and wipe containers dry before placing them in the refrigerator. This cuts down on moisture build-up inside the unit.
- Organize the refrigerator to reduce door openings. Remove as many items as needed at one time and close the door as soon as possible.
- Do not place a hot container directly on a cold shelf. Remember, such an extreme temperature change may damage the glass.

## 13. NORMAL OPERATING SOUNDS

### 13.1 Understanding the sounds you may hear

Your new, high-efficiency appliance may introduce unfamiliar sounds. These sounds normally indicate your appliance is operating correctly. Some surfaces on floors, walls, and kitchen cabinets may make these sounds more noticeable.

#### NOTE

Energy efficient foam in your appliance is not a sound insulator.

Following is a list of major components in your appliance and the sounds they can cause:

- A. Evaporator. Refrigerant through the evaporator may create a boiling or gurgling sound.
- B. Evaporator fan. You may hear air being forced through the refrigerator by the evaporator fan.
- C. Defrost heater. During defrost cycles, water dripping onto the defrost heater may cause a hissing or sizzling sound.

After defrosting, a popping sound may occur.

- D. Automatic Ice maker. When ice has been produced, you will hear ice cubes falling into the ice bin.
- E. Electronic control & automatic defrost control. These parts can produce snapping or clicking sound when turning the cooling system on and off.
- F. Condenser fan. You may hear air being forced through the condenser.
- G. Compressor. Modern, high-efficiency compressors run much faster than previous models. The compressor may have a noticeable hum or pulsating sound during operation.
- H. Water valve. Makes a buzzing sound each time it opens to fill the ice maker.
- I. Drain pan (not removable). You may hear water dripping into the drain pan during the defrost cycle.
- J. Condenser. May create minimal sounds from forced air.
- K. Motorized damper. May produce intermittent humming during operation.
- L. Ice chute. When dispensing ice, you will hear a snapping or clicking sound when the solenoid opens and closes the ice chute.

- M. Ice dispenser. When dispensing ice you can hear a snapping, clicking or popping sound.

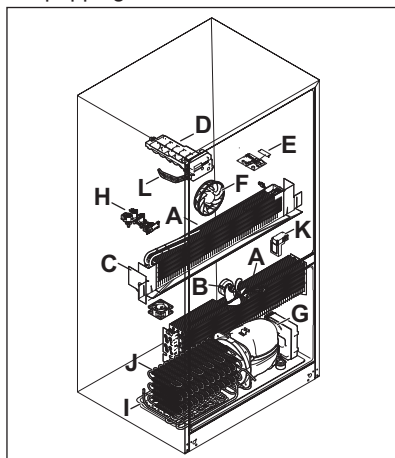

#### **NOTE**

During automatic defrost cycle, a red glow in the back wall vents of your freezer compartment is normal.

## 14. FILTER REPLACEMENT

### 14.1 PurePour Connect™ Water Filter

Keep safe, great-tasting water flowing with a PurePour Connect™ water filter. Using a PurePour Connect™ water filter:

- **Makes safe water second nature**  
PurePour Connect™ water filters are certified to reduce contaminants\* and keep great-tasting water flowing for you and your family.
- **Produces purity you can trust**  
Know for certain your PurePour Connect™ water filter is a protector. Counterfeits and knockoffs put your refrigerator and health at risk. Frigidaire Genuine Filters are the smarter, safer choice.
- **Every drop gives back**  
Partnered on sustainability efforts the use of a PurePour Connect™ water filter helps cut back on the cost and use of plastic used to produce and package bottled water

\*For the complete list, please see Performance Data Sheet on Frigidaire.com.

### 14.2 Ordering replacement filters

#### **NOTE**

When you order your replacement filter, please reorder the same filter type currently in your refrigerator.

To order your replacement filters, please call toll-free at 1-800-374-4432, or visit Frigidaire.com. Frigidaire recommends that you order extra filters when you first install your appliance, and that you replace your filters at least once every 6 months.

Here are the product numbers to request when ordering:

- PurePour Connect™ Water Filter PWF-1™ FPPWFUO1  
for models: GRMS2773, GRMN2872, FRMS2733

- PurePour Connect™ Water Filter PWF-2™ FPPWFUO2

for models: GRMC2273, GRMG2272

Find the Performance Data Sheet located in the Guides and Manuals section for your specific water filter on Frigidaire.com:

- PWF-1™ FPPWFUO1  
[Performance Data Sheet](#)
- PWF-2™ FPPWFUO2  
[Performance Data Sheet](#)

### 14.3 More about your advanced water filter



The PurePour Connect™ PWF-1™ FPPWFUO1, PurePour Connect™ PWF-2™ FPPWFUO2 ice and water filter system is tested and certified by IAPMO R&T against Standards 42, 53, 401 and NSF/ANSI/CAN 372CSA B483.1 in PurePour Connect™ PWF-1/PWF-2 for the reduction of claims specified on the Performance Data Sheet. Visit Frigidaire.com for more information.

Do not use with water that is microbiologically unsafe or of unknown quality without adequate disinfection before or after the system. Use systems certified for cyst reduction on disinfected waters that may contain filterable cysts.

#### Test & certification results

- Rated Capacity - 125 gal / 453 L for PurePour Connect™ and ice and water filter
- Rated service flow - .50 gal/min
- Operating Temperature: Minimum: 33°F, Maximum: 100°F
- Maximum rated pressure - 100 lbs/in<sup>2</sup>
- Recommended minimum operating pressure: 30 lbs/in<sup>2</sup>

#### PurePour Connect™ Authentication

Only for models: GRMC2273, GRMG2272

The refrigerator contains a water filter authentication system to protect you from the harm that can occur when using counterfeit filters. We recommend you use only the PurePour Connect™ water filter with this appliance. Using any other filter

can cause an error (Er FA) to appear on the appliance control display.

#### Errors can occur:

- If you remove and reinsert an authentic expired filter into the appliance.
- If you install an authentic, but incorrect filter.
- If you install a non-authentic filter.
- If you do not install the filter properly.

In the cases above, the appliance control display may show an error code related to the filter authentication, and Replace Water Filter appears on the display. You can still use dispensing functions while the error displays.

Press and hold the Water Filter button for 3 seconds to dismiss the error. You can dismiss the error twice. On the third appearance, the error code permanently displays on the appliance control until you install a new authentic filter.

### 14.4 Replacing your PurePour Connect™ water filter

The water filter is located at the top right side of the refrigerator compartment.

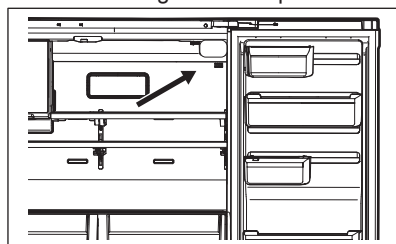

In general, you should change the water filter every 6 months to ensure the highest possible water quality. Water Filter Status on the user interface prompts you to replace the filter after a standard amount of water (125 gal / 453 L for PurePour Connect™) has flowed through the system.

If you have not used your appliance for a period of time (during moving for example), change the filter before reinstalling the appliance.

It is not necessary to turn the water supply off to change the filter. Small amounts of water may be released during the filter replacement.

1. Turn off the ice maker.

- Pull the water filter cover forward. Cover drops down to allow access to the filter.
- Remove the filter by pushing on the end/face of the filter.
- Slide the old water filter cartridge straight out of the housing and discard it.
- Unpack the new filter cartridge. Using the alignment guide, slide it gently into the filter housing until it stops against the snap-in connector at the back of the housing.
- Push firmly until the cartridge snaps into place. There is a clicking sound as the cartridge engages with the snap-in connector.
- Press a drinking glass against the water dispenser while checking for any leaks at the filter housing. Any spurts and sputters that occur as the system purges air out of the dispenser system are normal.
- Push the cover up toward the liner. Then push the filter cover toward the rear of the cabinet. The filter cover snaps back into place.
- After filling one glass of water, continue flushing the system for about 4 minutes.
- Once the filter is installed, the authentication process may take up to 30 seconds to complete. After authentication is complete, the filter status on the display automatically updates based on the condition of the filter.
- Turn on the ice maker.

### 14.5 PureAir Ultra II™ Air Filter

For some models.

The air filter is located in the top center of the fresh food compartment.

To order replacement filters, please visit our online store at [Frigidaire.com](http://Frigidaire.com) or call toll-free at 1-800-374-4432. Here are the product numbers to request when ordering:

- PureAir Ultra II™ Air Filter PAULTRA2

#### NOTE

We recommend you always use genuine Frigidaire replacement filters only.

### 14.6 Replacing your PureAir Ultra II™

To ensure optimal filtering of refrigerator odors, you should change the air filter every 6 months. Replace Air Filter on the appliance control display indicates replacing the filter after 6 months.

To remove and replace the air filter:

- Remove the air filter cover by squeezing the top and bottom of the cover together and removing from liner.
- Remove the old filter and discard it.
- Unpack the new filter and snap it into the filter cover. The open face (carbon media) of the filter should be installed facing outward in the cover.
- Replace the air filter cover by squeezing the sides and snapping it back into place.
- To reset, press and hold Reset Air Filter on the appliance control display for 3 seconds until you hear a sound.

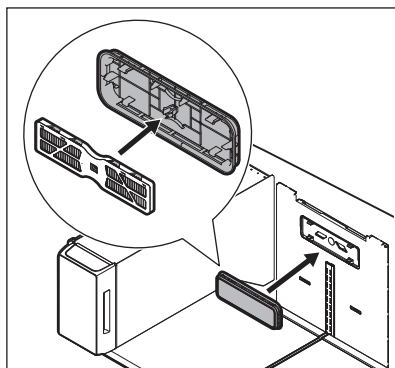

### 14.7 PureAir Produce Keeper Plus™

Keep fruits and vegetables fresher longer with PureAir Produce Keeper Plus™. Our produce keeper absorbs ethylene gas, the natural gas that causes produce to ripen quicker. Reduce food waste, save money and enjoy fresh-tasting produce with a longer storage life.

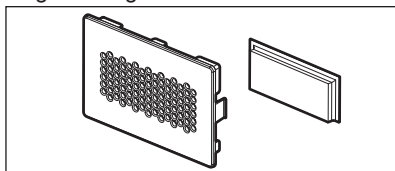

### Ordering Base Starter Kit

To keep food fresh for longer, you can purchase PureAir Produce Keeper Plus™ Base Starter Kit, one for each crisper drawer.

Here are the product numbers to request when ordering:

Part #FRPAPK2SKT

### Ordering Replacement Filters

To order your replacement filters, please visit our online store at Frigidaire.com, by calling toll-free at 1-800-374-4432, or by visiting the dealer where you purchased your refrigerator. Frigidaire recommends that you replace your filters at least once every 6 months.

Here are the product numbers to request when ordering:

PureAir Produce Keeper Plus™ PK-2 Part #FRPAPK2RF

## 14.8 Installing the PureAir Produce Keeper Plus™

1. Remove the plastic wrapper. Insert unopened packet into the holder in the crisper drawer.
2. For optimal results, replace the refill every 12 months along with your air filter.

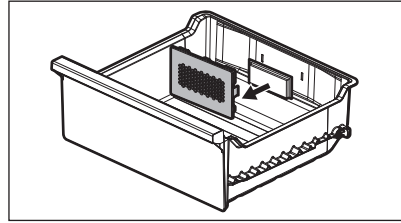

### ⚠ CAUTION!

- Do not open cloth pouch. Keep out of the reach of children.
- Do not eat. If ingested, seek medical treatment immediately.
- Wash hands after handling.
- Do not submerge in water.

## 15. CARE AND CLEANING

### 15.1 Protecting your investment

Keeping your appliance clean maintains its appearance and prevents odor build-up. Wipe up any spills immediately and clean the freezer and fresh food compartments at least twice a year. When cleaning, take the following precautions:

- Never use chloride or cleaners with bleach to clean stainless steel.
- Do not wash any removable parts in a dishwasher.
- Always unplug the electrical power cord from the wall outlet before cleaning.
- Do not remove the serial plate. Removal of your serial plate voids your warranty.
- Remove adhesive labels by hand. Do not use razor blades or other sharp instruments which can scratch the appliance surface.

Do not use abrasive cleaners such as window sprays, scouring cleansers, brushes, flammable fluids, cleaning waxes, concentrated detergents, bleaches or cleansers containing petroleum

products on plastic parts, interior doors, gaskets or cabinet liners. Do not use paper towels, metallic scouring pads, or other abrasive cleaning materials or strong alkaline solutions.

Refer to the guide below for more details on caring and cleaning specific areas of your appliance.

### ⚠ CAUTION!

Pull the appliance straight out to move it. Shifting it from side to side may damage flooring. Be careful not to move the appliance beyond the plumbing connections.

### 📌 IMPORTANT

If you store or move your appliance in freezing temperatures, be sure to completely drain the water supply system. Failure to do so could result in water leaks when the appliance is put back into service. Contact a service representative to perform this operation.

## 15.2 Vacation and moving tips

Occasion	Tips
Short vacations	<ul style="list-style-type: none"> <li>• Leave the appliance operating during vacations of three weeks or less.</li> <li>• Use all perishable items from the appliance compartment.</li> <li>• Turn automatic ice maker off and empty ice bucket, even if you will only be gone a few days.</li> </ul>
Long vacations	<ul style="list-style-type: none"> <li>• Remove all food and ice if you will be gone one month or more.</li> <li>• Turn water supply valve to closed position.</li> <li>• Clean interior thoroughly.</li> <li>• Leave both doors open to prevent odors and mold build-up. Block doors open if necessary.</li> </ul>
Moving	<ul style="list-style-type: none"> <li>• Unplug the appliance</li> <li>• Remove all food and ice.</li> <li>• Recommend use of a handcart, load from the side.</li> <li>• Adjust rollers all the way up to protect them during sliding or moving.</li> <li>• Pad cabinet to avoid scratching surface.</li> </ul>

## 15.3 Care & Cleaning Tips

Part	What to use	Tips and precautions
Interior and door liners	<ul style="list-style-type: none"> <li>• Soap and water</li> <li>• Baking soda and water</li> </ul>	Use 2 tablespoons of baking soda in 1 quart of warm water. Be sure to wring excess water out of sponge or cloth before cleaning around controls, light bulb or any electrical part.
Door gaskets	Soap and water	Wipe gaskets with a clean soft cloth.
Glass shelves	<ul style="list-style-type: none"> <li>• Soap and water</li> <li>• Glass cleaner</li> <li>• Mild liquid sprays</li> </ul>	Allow glass to warm to room temperature before immersing in warm water.
Exterior and handles	<ul style="list-style-type: none"> <li>• Soap and water</li> <li>• Non abrasive glass cleaner</li> </ul>	Do not use commercial household cleaners containing ammonia, bleach or alcohol to clean handles. Use a soft cloth to clean smooth handles. Do not use a dry cloth to clean smooth doors.
Exterior and handles (Stainless steel models only)	<ul style="list-style-type: none"> <li>• Soap and water</li> <li>• Stainless steel cleaners</li> </ul>	Never use chloride or cleaners with bleach to clean stainless steel. Clean stainless steel front and handles with non-abrasive soapy water and a dishcloth. Rinse with clean water and a soft cloth. Use a non-abrasive stainless steel cleaner. These cleaners can be purchased at most home improvement or major department stores. Always follow manufacturer's instructions. Do not use household cleaners containing ammonia or bleach. Always clean, wipe and dry with the grain to prevent scratching. Wash the rest of the cabinet with warm water and mild liquid detergent. Rinse well, and wipe dry with a clean soft cloth.

## 16. TROUBLESHOOTING

Let us help you troubleshoot your concern! This section will help you with common issues. If you need us, visit our website, chat with an agent, or call us. We may be able to help you avoid a service visit. If you do need service, we can get that started for you! Visit Frigidaire.com or call toll-free 1-800-374-4432.

### Automatic Ice Maker

Concern	Potential Cause	Common solution
Ice maker is not making any ice.	Ice maker is turned off.	Refer to Ice Maker and Controls and Settings. <b>Fresh Food Ice Maker:</b> Press and hold the ice maker button on the appliance control for 3 seconds to turn the ice maker on. The LED indicator illuminates to indicate the ice maker is on. <b>Freezer Ice Maker:</b> Press or slide the power button to turn the ice maker on. The button and LED illuminate when active.
	Refrigerator is not connected to water line or water valve is not open.	Connect the unit to the household water supply and ensure the water valve is open.
	The water supply line is kinked.	Ensure that the supply line does not kink when the refrigerator is pushed into place against the wall.
	The water filter is not seated properly.	Remove and re-install the water filter. Be sure to seat it fully into the locked position.
	The water filter may be clogged with foreign material.	If water dispenses slowly or not at all, or if the filter is 6 months old or older, it should be replaced.

Concern	Potential Cause	Common solution
Ice maker is not making enough ice.	Ice maker is producing less ice than you expect.	
	The water filter may be clogged with foreign material.	If water dispenses slower than normal, or if the filter is six months old or older, it should be replaced.
	Saddle valve on cold water pipe is clogged or restricted by foreign material.	Ensure that the supply line does not kink when the refrigerator is pushed into place against the wall.
	Heavy traffic, opening or closing of the doors excessively.	Turn off household water line valve. Remove valve. Clean valve. Replace valve if necessary.
	Freezer control is set too warm (freezer ice maker).	Set freezer control to colder setting to improve performance of the ice maker (freezer ice maker). Allow 24 hours for temperature to stabilize.
	Water pressure is extremely low. Cut-off and cut-on pressures are too low (well systems only).	Have someone turn up the cut-off and cut-on pressure on the water pump system (well systems only).
Freezer ice maker will not stop making ice (some models).	Reverse osmosis system is in regenerative phase.	It is normal for a reverse osmosis system to be below 20 psi during the regenerative phase.
	Ice maker bail arm is being held down by a package in the freezer that has fallen against ice maker.	Move any item or frozen ice cubes that may block the bail arm from being in the off or upward position.
Ice cubes are freezing together.	Ice cubes are located in once spot inside the freezer ice bin.	Periodically move ice cubes around the ice bin so that ice maker will continue to make ice.
	Ice cubes are not being used frequently enough or interruption of power for prolonged time.	Remove ice container and discard ice. The ice maker will produce fresh supply. Ice should be used at least twice weekly to keep the cubes separated.
Ice cubes are freezing together.	Ice cubes are hollow (shells of ice with water inside). The hollow cubes break open in the bin and leak their water onto existing ice, which causes it to freeze together.	<ul style="list-style-type: none"> <li data-bbox="689 1084 972 1230">• This generally occurs when the ice maker does not get enough water. This is usually the result of a clogged water filter or restricted water supply.</li> <li data-bbox="689 1239 972 1382">• Replace the water filter and if the condition still occurs check for a clogged saddle valve, water valve not turned on all the way or kinked water supply line.</li> </ul>

## Ice and water dispenser

Concern	Potential cause	Common solution
Dispenser does not dispense ice.	There is no ice in the bin to be dispensed.	See the section above: Ice maker is not making any ice.
	The refrigerator doors are not completely closed.	Completely close the refrigerator doors.
	Dispenser paddle has been pressed too long and the dispenser motor has overheated.	The motor overload protector will reset in about 3 minutes, and then ice can be dispensed.
	Not dispensing ice regularly may melt and re-freeze ice causing ice clumping. Dispensing clumps could damage the ice bucket.	Empty the ice bucket monthly or regularly dispense ice. For longer periods of time (vacation or vacant homes) turn off the ice maker. See tips in Automatic Ice and Water Dispenser.
Ice dispenser is jammed.	Ice has melted and frozen around auger due to infrequent use, temperature fluctuations, and/or power outages.	Remove ice container, thaw, and empty the contents. Clean container, wipe dry, and replace in proper position. When new ice is made, dispenser should operate. See tips on cleaning in Automatic Ice and Water Dispenser.
	Ice cubes are jammed between ice maker and back of ice container.	Remove ice cubes that are jamming the dispenser.
Dispenser does not dispense water.	Water filter not seated properly.	Remove and reinstall the water filter. For PurePour Connect™, be sure to push the filter in all the way until it clicks into place and is secured inside of the water filter housing.
	Water filter is clogged.	Replace filter cartridge. Be sure to push filter all the way in until it clicks into place and is secured inside of the water filter housing.
	Household water line valve is not open.	Open household water line valve.
Water not cold enough.	The water dispensing system is not designed to chill water. As warmer tap water goes through the filter and enters the water supply system, the chilled water is pushed through to the dispenser. Once the chilled water is used up, it will take several hours to bring the freshly replaced water to a cooler temperature.	Add ice to cup or container before dispensing water. Only the first 26 oz are chilled.
Water has an odd taste and/or odor.	Water has not been dispensed for an extended period of time.	Draw and discard 10-12 glasses of water to freshen the supply.
	The appliance not properly connected to cold water line.	Connect the appliance to cold water line that supplies water to the kitchen faucet.

## Opening/Closing of Doors/Drawers

Concern	Potential cause	Common solution
Door(s) does not close.	Door was closed too hard, causing other door to open slightly.	Close both doors gently.
	Refrigerator is not level. It rocks on the floor when moved slightly.	Ensure floor is level and solid, and can adequately support the refrigerator. Contact a carpenter to correct a sagging or sloping floor.
	Refrigerator is touching a wall or cabinet.	Ensure floor is level and solid, and can adequately support the refrigerator. Contact a carpenter to correct a sagging or sloping floor.
	Food/packaging is obstructing the door from closing.	Make sure there is no food/packaging blocking the doorway.
Doors are not aligned.	Flipper mullion on left fresh food door is not in the correct position.	Ensure the flipper mullion is in the correct position to allow the door to close. Refer to Flipper Mullion Installation.
Drawers are difficult to move.	Food is touching shelf on top of drawer.	Remove top layer of items in drawer.
	Track that drawers slide on is dirty.	<ul style="list-style-type: none"> <li>• Ensure drawer is properly installed on track.</li> <li>• Clean drawer, rollers, and track. Refer to Care and Cleaning.</li> </ul>

## Running of appliance

Concern	Potential cause	Common solution
Compressor does not run.	The appliance is unplugged.	Ensure plug is tightly pushed into outlet.
	Refrigerator is in defrost cycle.	This is normal for a fully automatic defrost refrigerator. The defrost cycle occurs periodically, lasting about 30 minutes.
	House fuse blown or tripped circuit breaker.	Check/replace fuse with a 15 amp time-delay fuse. Reset circuit breaker.
	Power outage.	Check house lights. Call local electric company.
Refrigerator seems to run too much or too long.	The variable speed compressor is designed to run 100% of the time except during the defrost cycle. At times it will run faster, such as after a defrost cycle.	It is normal for the compressor to run continuously except during defrost mode.
One compartment feels cooler than the other after installation.	This appliance is equipped with a refrigeration system that changes between compartments periodically.	This is normal behavior right after installation. Allow 24 hours for the appliance to stabilize and reach the desired temperatures.

## Digital temperature display

Concern	Potential cause	Common solution
Digital temperature displays an error.	Electronic control system has detected a performance problem.	Call your Frigidaire service representative, who can interpret any messages or number codes flashing on the digital displays.

## Water/Moisture/Frost Inside Refrigerator

Concern	Potential cause	Common solution
Moisture collects on inside of refrigerator walls.	Weather is hot and humid.	The rate of frost buildup and internal sweating increases.
	Flipper mullion	Adjust flipper mullion. Refer to Flipper Mullion in Installation.
	Door is slightly open.	See the Opening/Closing of Doors/Drawers section above.
Water collects on bottom side of drawer cover.	Vegetables contain and give off moisture.	<ul style="list-style-type: none"><li>• It is not unusual to have moisture on the bottom side of the cover.</li><li>• Move humidity control (some models) to lower setting.</li><li>• Both crispers contain an automatic humidity control, which should adjust automatically to the varying levels of moisture inside the drawer without creating additional condensation or drying out the air inside the crisper drawer, works with various types of produce. If you notice excess moisture, check to verify humidity membrane is not damaged and replace as necessary.</li></ul>
		Water collects in bottom of drawer.

## Water/Moisture/Frost Outside Refrigerator

Concern	Potential cause	Common solution
Moisture collects on outside of refrigerator or between doors.	Weather is humid.	This is normal in humid weather. When humidity is lower, the moisture should disappear.
	Door is slightly open, causing cold air from inside refrigerator to meet warm air from outside.	See the Opening/Closing of Doors/Drawers section above.

## Food in Fresh food compartment

Concern	Potential cause	Common solution
Food is freezing.	Temperature setting is too low.	Move the setting to a higher degree.
	Temperature sensor is covered by food (right side of fresh food area).	Allow space for air flow to the sensor.
	Food is covering the air ports.	Allow space between the air ports and the food.

## 17. LIMITED WARRANTY

Your appliance is covered by a one year limited warranty. For one year from your date of delivery, Electrolux will pay all costs for repairing or replacing any parts of this appliance that prove to be defective in materials or workmanship when such appliance is installed, used and maintained in accordance with the provided instructions.

### Exclusions

This warranty does not cover the following:

1. Products with original serial numbers that have been removed, altered or cannot be readily determined.
2. Product that has been transferred from its original owner to another party or removed outside the USA, Puerto Rico, or Canada.
3. Rust on the interior or exterior of the unit.
4. Products purchased "as-is" are not covered by this warranty.
5. Food loss due to any refrigerator or freezer failures.
6. Products used in a commercial setting.
7. Service calls which do not involve malfunction or defects in materials or workmanship, or for appliances not in ordinary household use or used other than in accordance with the provided instructions.
8. Service calls to correct the installation of your appliance or to instruct you how to use your appliance.
9. Expenses for making the appliance accessible for servicing, such as removal of trim, cupboards, shelves, etc., which are not a part of the appliance when it is shipped from the factory.
10. Service calls to repair or replace appliance light bulbs, air filters, water filters, other consumables, or knobs, handles, or other cosmetic parts.

11. Surcharges including, but not limited to, any after hour, weekend, or holiday service calls, tolls, ferry trip charges, or mileage expense for service calls to remote areas, including the state of Alaska.

12. Damages to the finish of appliance or home incurred during transportation or installation, including but not limited to floors, cabinets, walls, etc.

13. Damages caused by: services performed by unauthorized service companies; use of parts other than genuine Electrolux parts or parts obtained from persons other than authorized service companies; or external causes such as abuse, misuse, inadequate power supply, accidents, fires, or acts of God.

### DISCLAIMER OF IMPLIED WARRANTIES; LIMITATION OF REMEDIES

CUSTOMER'S SOLE AND EXCLUSIVE REMEDY UNDER THIS LIMITED WARRANTY SHALL BE PRODUCT REPAIR OR REPLACEMENT AS PROVIDED HEREIN. CLAIMS BASED ON IMPLIED WARRANTIES, INCLUDING WARRANTIES OF MERCHANTABILITY OR FITNESS FOR A PARTICULAR PURPOSE, ARE LIMITED TO ONE YEAR OR THE SHORTEST PERIOD ALLOWED BY LAW, BUT NOT LESS THAN ONE YEAR. ELECTROLUX SHALL NOT BE LIABLE FOR CONSEQUENTIAL OR INCIDENTAL DAMAGES SUCH AS PROPERTY DAMAGE AND INCIDENTAL EXPENSES RESULTING FROM ANY BREACH OF THIS WRITTEN LIMITED WARRANTY OR ANY IMPLIED

WARRANTY. SOME STATES AND PROVINCES DO NOT ALLOW THE EXCLUSION OR LIMITATION OF INCIDENTAL OR CONSEQUENTIAL DAMAGES, OR LIMITATIONS ON THE DURATION OF IMPLIED WARRANTIES, SO THESE LIMITATIONS OR EXCLUSIONS MAY NOT APPLY TO YOU. THIS WRITTEN WARRANTY GIVES YOU SPECIFIC LEGAL RIGHTS. YOU MAY ALSO HAVE OTHER RIGHTS THAT VARY FROM STATE TO STATE.

**If You Need Service**

Keep your receipt, delivery slip, or some other appropriate payment record to establish the warranty period should service be required. If service is performed, it is in your best interest to obtain and keep all receipts. Service under this warranty must be obtained by contacting Electrolux at the addresses or phone numbers below.

This warranty only applies in the USA, Puerto Rico and Canada. In the USA and Puerto Rico, your appliance is warranted

by Electrolux Consumer Products, Inc. In Canada, your appliance is warranted by Electrolux Canada Corp. Electrolux authorizes no person to change or add to any obligations under this warranty. Obligations for service and parts under this warranty must be performed by Electrolux or an authorized service company. Product features or specifications as described or illustrated are subject to change without notice.

**USA**

**1-800-374-4432**

Electrolux Consumer Products, Inc.  
10200 David Taylor Drive  
Charlotte, NC 28262

**Canada**

**1-800-265-8352**

Electrolux Canada Corp.  
5855 Terry Fox Way  
Mississauga, Ontario, Canada L5V 3E4







**18. QUEBEC RIGHT TO REPAIR**

Though Frigidaire makes every effort to make replacement parts, repair services and information necessary to maintain or repair our products available to consumers, parts, service and information are not guaranteed, pursuant to section 39 of the Consumer Protection Act, CQLR, c. P-40.1 and sections 79.18 to 79.20 of the Regulation respecting the application of the Consumer Protection Act, CQLR, c. P-40.1, r. 3. If you need replacement parts, you may call us at 1 (800) 265-8352 for service in French or English, or purchase online at **Frigidaire Parts | Shop Frigidaire Replacement Parts & Accessories - Frigidaire Appliance Parts.**

You may book repair services online at [information](#) | [Book a service](#) | [Frigidaire](#). Alternatively, our resource library is available at **Resource Library | Frigidaire** to help you diagnose and resolve issues which may arise during the lifetime of your appliance.

Though most parts are available for purchase, subject to short-term availability constraints, the following appliances and parts are not serviceable.

**Legend**

Availability of replacement parts, repair services, and information for maintenance or repair.		
	Partially Available	
	Not Available	
	Available	
<b>Refrigerators</b>		Cabinet, 14cu ft and less no sealed system parts
<b>Freezer</b>		9 cu. ft and less no sealed system parts.
<b>Beverage Centers</b>		Only cosmetic parts available

