

EN User Manual | Fridge Freezer



Welcome to our family

Thank you for bringing Frigidaire into your home! We see your purchase as the beginning of a long relationship together.

This manual is your resource for the use and care of your product. Please read it before using your appliance. Keep it handy for quick reference. If something doesn't seem right, the troubleshooting section will help you with common issues.

FAQ, helpful tips and videos, cleaning products, and kitchen and home accessories are available at <http://www.frigidaire.com>.

We are here for you! Visit our website, chat with an agent, or call us if you need help. We may be able to help you avoid a service visit. If you do need service, we can get that started for you.

Let's make it official! Be sure to register your product.

CONTENTS

1. IMPORTANT SAFETY INFORMATION.....	2
2. INSTALLATION.....	5
3. DOOR REVERSAL.....	7
4. DOOR HANDLE INSTALLATION.....	8
5. FEATURES.....	9
6. CONTROLS AND SETTINGS.....	9
7. STORAGE FEATURES.....	10
8. STORING FOOD AND SAVING ENERGY.....	11
9. WATER SUPPLY CONNECTION.....	12
10. NORMAL OPERATING SOUNDS.....	14
11. CARE AND CLEANING.....	14
12. TROUBLESHOOTING.....	15
13. LIMITED WARRANTY.....	16
14. QUEBEC RIGHT TO REPAIR.....	17

1. IMPORTANT SAFETY INFORMATION

1.1 Keep a record for quick reference

Model number
.....
Serial number
.....
Purchase date
.....

1.2 Serial number location

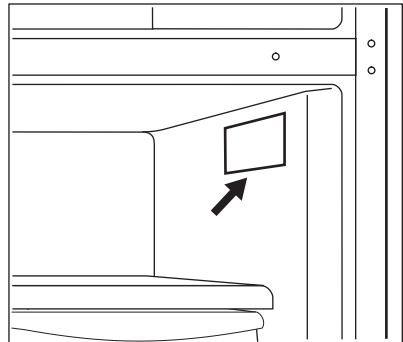

 **WARNING!**

You must follow these guidelines to ensure that your appliance's safety mechanisms are operating correctly.

1.3 Safety definitions



This is the safety alert symbol. It is used to alert of potential personal injury hazards. Obey all safety messages that follow this symbol to avoid possible injury or death.

 **DANGER**

DANGER indicates an imminently hazardous situation which, if not avoided, will result in death or serious injury.

 **WARNING!**

WARNING indicates a potentially hazardous situation which, if not avoided, could result in death or serious injury.

 **CAUTION!**

CAUTION indicates a potentially hazardous situation which, if not avoided, may result in minor or moderate injury.

 **IMPORTANT**

IMPORTANT indicates installation, operation or maintenance information which is important but not hazard-related.

1.4 Child safety

This appliance is not intended for use by persons (including children) with reduced physical, sensory or mental capabilities, or lack of experience and knowledge, unless they have been given supervision or instruction concerning use of the appliance by a person responsible for their safety.

Destroy or recycle the carton, plastic bags, and any exterior wrapping material immediately after the appliance is unpacked. Children should never use these items to play. Cartons covered with rugs, bedspreads, plastic sheets or stretch wrap may become airtight chambers, and can quickly cause suffocation.

1.5 Important safety instructions

 **DANGER**



DANGER Risk of fire or explosion. Flammable refrigerant used. Do not use mechanical devices to defrost refrigerator. Do not puncture refrigerant tubing. DANGER Risk of fire or explosion. Flammable refrigerant used. To be repaired only by trained service personnel. Use only manufacturer-authorized service parts. Any repair equipment used must be designed for flammable refrigerants. Follow all manufacturer repair instructions. Do not puncture refrigerant tubing.

 **CAUTION!**



CAUTION Risk of fire or explosion due to puncture of refrigerant tubing. Follow handling instructions carefully. Flammable refrigerant used.

This appliance is for storage only and should not be used for any other purpose.

Do not store or use gasoline or other flammable vapors and liquids in the vicinity of this or any other appliance.

Do not store explosive substances such as aerosol cans with a flammable propellant in this appliance.

Do not operate the refrigerator in the presence of explosive fumes. Avoid contact with any moving parts of automatic ice maker.

Remove all staples from the carton. Staples can cause severe cuts, and also destroy finishes if they come in contact with other appliances or furniture.

⚠ WARNING!

Do not use electrical appliances inside the food storage compartments of the appliance unless they are of the type recommended by the manufacturer.

⚠ WARNING!

CALIFORNIA RESIDENTS ONLY
WARNING! Cancer and Reproductive Harm <http://www.P65Warnings.ca.gov>

1.6 Proper disposal of your refrigerator or freezer

⚠ CAUTION!

CAUTION Risk of fire or explosion. Dispose of refrigerator properly in accordance with the applicable federal or local regulations. Flammable refrigerant used.



Risk of child entrapment

Child entrapment and suffocation are not problems of the past. Junked or abandoned refrigerators or freezers are still dangerous – even if they will sit for “just a few days”. If you are getting rid of your old refrigerator or freezer, follow the instructions below to help prevent accidents.

We strongly encourage responsible appliance recycling/disposal methods. Check with your utility company or visit <http://www.energystar.gov/recycle> for more information on recycling your old refrigerator.

Before you throw away your old refrigerator/freezer:

- Remove doors.
- Leave shelves in place so children may not easily climb inside.
- Have it removed by a qualified service technician.

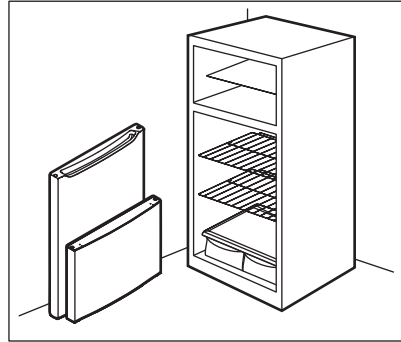

1.7 Electrical information

- The appliance must be plugged into its own dedicated 115 Volt, 60 Hz., 15 Amp, AC only electrical outlet. The power cord of the appliance is equipped with a three-prong grounding plug for your protection against electrical shock hazards. It must be plugged directly into a properly grounded three-prong receptacle. The receptacle must be installed in accordance with local codes and ordinances. Consult a qualified electrician. Do not use an extension cord or adapter plug.

⚠ WARNING!

Avoid fire hazard or electric shock.

- If the power cord is damaged, it should be replaced by an authorized service technician to prevent any risk.

- Never unplug the appliance by pulling on the power cord. Always grip the plug firmly, and pull straight out from the receptacle to prevent damaging the power cord.
- Unplug the appliance before cleaning and before replacing the AC LED light bulb to avoid electrical shock.
- Performance may be affected if the voltage varies by 10% or more. Operating the appliance with insufficient power can damage the compressor. Such damage is not covered under your warranty.
- Do not plug the unit into an electrical outlet controlled by a wall switch or pull cord to prevent the appliance from being turned off accidentally.
- Do not pinch, knot, or bend the power cord in any manner.

WARNING!

When positioning the appliance, ensure the supply cord is not trapped or damaged.
Do not locate multiple portable socket-outlets or portable power supplies at the rear of the appliance.

WARNING!

Do not, under any circumstances, cut, remove, or bypass the grounding prong (A). Always use the power cord with a three-prong grounded plug and grounding type wall receptacle.



2. INSTALLATION

This User Manual provides general installation and operating instructions for your model. We recommend using a service or kitchen contracting professional to install your appliance. Use the appliance only as instructed in this User Manual. Before starting the appliance, follow these important first steps.

2.1 ✓ Installation Checklist

Doors

- Handles are secure and tight (some models)
- Refrigerator door seals completely to the cabinet on all sides
- Freezer door is level from side to side across the top

Leveling

- Appliance is level side-to-side and tilted 1/4" (6 mm) front-to-back
- Cabinet is setting solid on all corners
- Anti-tip bracket set in front on both sides

Electrical Power

- House power is turned on
- Appliance is plugged in

Ice Maker

- House water supply is connected to the appliance

WARNING!

Potable water supply only.

- No water leaks present in any connections - recheck in 24 hours
- Ice maker is turned on

Final Checks

- Shipping material is removed
- Refrigerator and freezer temperatures are set
- Registration card is sent in

2.2 Cleaning the appliance

IMPORTANT

Remove tape and glue residue from surfaces before turning the appliance on. Rub a small amount of liquid dish soap over the adhesive with your fingers. Rinse with warm water and dry with a soft cloth.

Do not use sharp instruments, rubbing alcohol, flammable fluids, or abrasive cleaners to remove tape or glue.

These products can damage the surface of the appliance.

After you remove all of the package materials, clean the inside of the appliance before using it. Refer to Care and Cleaning.

2.3 Moving the appliance

IMPORTANT

The appliance is heavy. When moving the appliance for cleaning or service, raise the anti-tip bracket (refer to Setting the anti-tip brackets). Be sure to cover the floor with cardboard or hardboard to avoid floor damage. Always pull the appliance straight out when moving it. Do not wiggle or "walk" the appliance when trying to move it as you could damage the floor.

2.4 Location

- If possible, place the appliance out of direct sunlight and away from the range, dishwasher, or other heat sources.
- The appliance must be installed on a floor that is level and strong enough to support a fully loaded appliance.
- Consider water supply availability for models equipped with an automatic ice maker.

WARNING!

This appliance is intended for use in residential household and similar interior applications such as:

- Kitchen / kitchenette
- Pantry room
- Basement
- Enclosed garage
- Other interior residential type environments

CAUTION!

Do not install the appliance where the temperature will drop below 44°F (7°C) or rise above 110°F (43°C).

The compressor will not be able to maintain proper temperatures inside the appliance.

NOTE

Do not block the lower front of the appliance.

Sufficient air circulation is essential for the proper operation of the appliance.

WARNING!

Allow the following clearances for ease of installation, proper air circulation, plumbing, and electrical connections:

- Top 3/8" (9.5 mm)
- Sides 3/8" (9.5 mm)
- Back 2" (50.8 mm)

NOTE

The exterior walls of the appliance may become warm as the compressor transfers heat from the inside. The temperatures may be even 30°F higher than the room temperature. In hotter climates it is important to allow enough space for air circulation around the appliance.

NOTE

If you place the appliance with the door hinge side against a wall, you may have to allow additional space so the door can be open wider.

2.5 Cabinet leveling and door alignment

Guidelines for final positioning of appliance:

- All 4 corners of the cabinet must rest firmly on the floor.
- The cabinet should be level at the front and rear.
- The sides should tilt 1/4" (6 mm) from front to back to ensure that doors close and seal properly.
- Align the doors with each other and level them.

2.6 Connecting the appliance

After installation, wait at least 2 hours before switching on the power. Switching on the appliance too soon can reduce cooling performance or cause damage.

IMPORTANT

Let the appliance run empty for 24 hours to cool the compartment to the correct temperature.

3. DOOR REVERSAL

CAUTION!

To avoid injury or damage, have someone assist you during door reversal.

NOTE

Unplug and empty the appliance. Keep all the removed parts to reuse them later.

1. Remove the left cover plate and the right top hinge cover. Unscrew screws and remove the right top hinge.

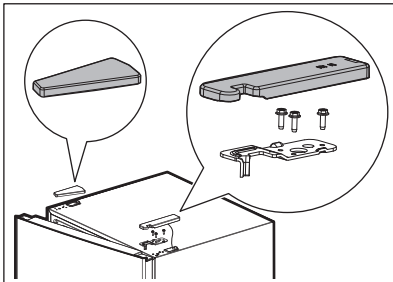

2. Lift the freezer door up and away from the appliance.
3. Unscrew and remove the middle hinge. Lift the refrigerator door up and away.

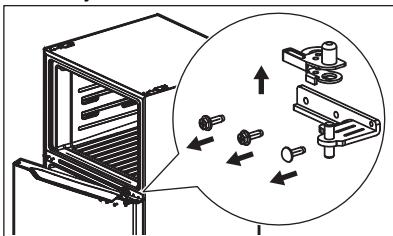

4. Unscrew and remove the bottom hinge.
5. Unscrew the hinge shaft from the right side of the bottom hinge and move it to the left side. Secure the bottom hinge to the bottom left side of the appliance.

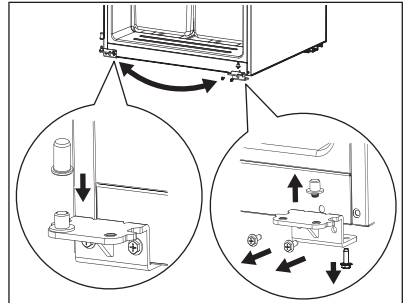

6. Dismantle the sleeves from the top right of doors and hole cap from top left of doors, and assemble them on the other side.

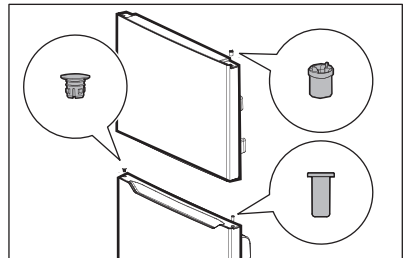

7. Remove the refrigerator door stopper and install it on the other side of the door. Remove the freezer door self-locking block and stopper. Save them to reuse. Take out the left self-locking block and stopper from the accessory

bag and install them on the left of door.

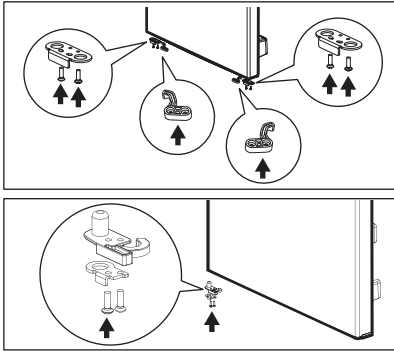

8. Take out the center hinge from the accessory bag assemble it.

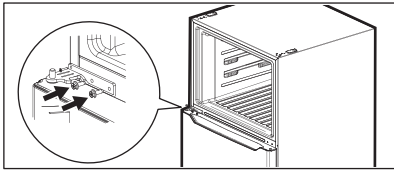

9. Put down the freezer door on the middle hinge.
10. Take out the top hinge and cover from the accessory bag. Assemble the top hinge, hinge cover and hole cover.

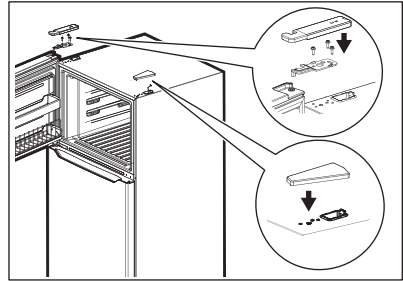

4. DOOR HANDLE INSTALLATION

IMPORTANT

Do not use a power tool to unscrew or tighten parts.

To install the door handle:

- To install part A:
 - Locate the holes in the door where part A should be installed.
 - With a #3 Phillips head screwdriver install part A. Use firm pressure during installation.
 - Ensure part A ends up flush against the cabinet before proceeding to install the handle.
- Remove the handles and any other protective packaging from the carton.
- Position the handle end caps over upper and lower pre-installed shoulder bolts (A) that are fastened into door, ensuring the holes for the set screws are facing towards the opposite door.
- While holding handle firmly against door, fasten upper and lower Allen set screws (B) with supplied Allen wrench.

5. Repeat the steps above to install the opposite handle. Ensure the holes for the set screws are facing towards the opposite door.

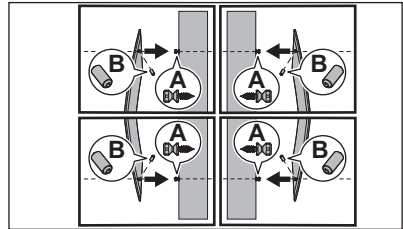

NOTE

When tightening the Allen set screws, apply force to the longer arm of the Allen wrench supplied in the handle packaging.

5. FEATURES

▶ IMPORTANT

*Features may vary by model.

Accessories are available for your appliance and may be purchased at Frigidaire.com or by calling toll-free 1-800-374-4432.

5.1 Product overview

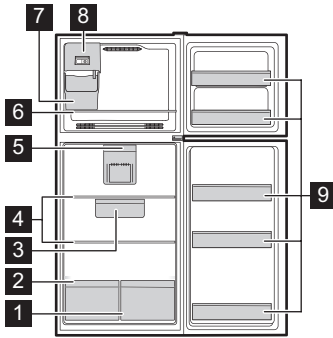

- 1 Crisper
- 2 Crisper Cover
- 3 Deli Drawer*
- 4 Full Shelves
- 5 Refrigerator Control
- 6 Freezer Shelf
- 7 Ice Bin*
- 8 Ice Maker*
- 9 Fixed Door Bins

6. CONTROLS AND SETTINGS

TEMPZONE

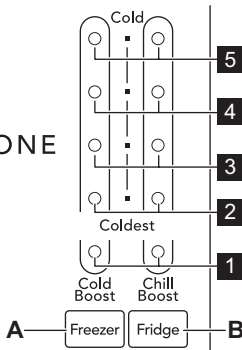

- A. Freezer** button and indicators
B. Fridge button and indicators
- 1 LED 1A; Cold Boost and LED 1B; Chill Boost
 - 2 LED 2A and 2B; Coldest
 - 3 LED 3A and 3B; Recommended
 - 4 LED 4A and 4B; Recommended
 - 5 LED 5A and 5B; Cold

Temperature adjustment

- For colder temperatures, press the Freezer/Fridge button to change the temperature setting toward Coldest.
- For warmer temperatures, press the Freezer/Fridge button to change the temperature setting toward Cold.

Pressing the Freezer and Fridge buttons scrolls through the 5 temperature settings toward the coldest setting, and then loop back to the least coldest setting.

⚠ NOTE

Adjusting the refrigerator control changes temperature in both compartments.

To maintain temperatures, a fan circulates air in the refrigerator and freezer compartments. For good circulation, do not block cold air vents with food items.

Cold Boost function

To activate or deactivate the function, press the Freezer button until the Cold Boost indicator (LED 1A) lights up. The function turns off automatically after 40

hours and the compartment returns to the previously set temperature. To turn off the function manually, press the Freezer button to set a different temperature.

Chill Boost function

To activate or deactivate the function, press the Fridge button until Chill Boost indicator (LED 1B) lights up. The function turns off automatically after 6 hours and the compartment returns to the previously set temperature. To turn off the function manually, press the Fridge button to set a different temperature.

6.1 Sabbath Mode

The Sabbath Mode disables parts of the appliance and its controls to support observance of the weekly Sabbath and religious holidays in the Orthodox Jewish community. The compressor and fan keep working in normal mode. Their operation does not change when the door opens or closes.

NOTE

The temperature setting is not affected by the Sabbath mode. Sounds and alarms are off. If a fault occurs, the appliance keeps working in the preset fault mode, but it does not show an error code or make a sound.

To enter Sabbath mode:

Press and hold the **Freezer** and **Fridge** buttons for 5 seconds.

The LEDs 2A, 2B, 5A, and 5B light up and stay on when the function is active.

To exit Sabbath mode, reverse the steps above.

NOTE

While in Sabbath mode, the lights and the control panel do not work until Sabbath mode is deactivated. The appliance stays in Sabbath mode after power failure recovery. Deactivate it with the appliance control.



For further assistance, guidelines for proper use and a complete list of models with the Sabbath feature, please visit star-k.org.

6.2 Errors

The following error codes can appear on the control panel to indicate a malfunction. The appliance may operate despite the following errors.

The LEDs are numbered from the bottom to the top of the control panel. Refer to the Temperature Control section.

Error	Description
Flashing left LED 1 / right LED 2.	Refrigerator temperature sensor failure.
Flashing left LED 2 / right LED 2.	Freezer temperature sensor failure.
Flashing left LED 1 / right LED 3.	Freezer defrost sensor failure.
Flashing left LED 1 / right LED 1.	Communication failure.
Flashing left LED 2 / right LED 1.	The ambient temperature sensor failure.
Flashing left LED 3 / right LED 3.	Freezer fan feedback failure.

7. STORAGE FEATURES

Equipment varies by model.

7.1 Door Bins

To remove the door bin:

1. Lift the bin up.
2. Pull it straight out.

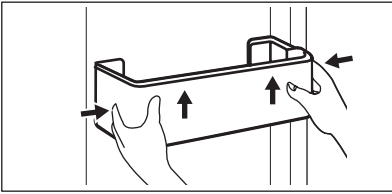

7.2 Shelves

To remove the shelves:

1. Lift the shelf.
2. Pull it straight out.

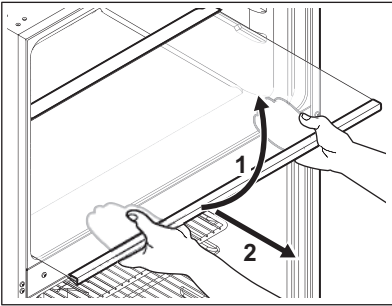

7.3 Removing/Installing crisper drawers

Use the crisper to keep produce fresh for longer.

You can remove the drawer for cleaning. To remove the drawer:

1. Pull the drawer out until it stops.
2. Lift the front slightly and remove the drawer.

To install the drawer, reverse the procedure.

8. STORING FOOD AND SAVING ENERGY

8.1 Ideas for storing food

Fresh food storage

- Keep the fresh food compartment between 34°F and 40°F, with an optimum temperature of 37°F.
- Avoid overcrowding the refrigerator shelves, which reduces air circulation and causes uneven cooling.
- Avoid placing food in front of air ports.

Fruits and vegetables

- Store fruits and vegetables in crisper drawers, where trapped moisture helps preserve food quality for longer time periods.
- Wash items and remove excess water.
- Wrap any items that have strong odors or high moisture content.

Meat

- Wrap raw meat and poultry separately and securely to prevent leaks and contamination of other foods or surfaces.

- Use the deli drawer to store meat/poultry for short-term storage. Any meat to be kept longer than two days should be frozen.

Frozen foods storage

- Keep the freezer compartment at 0°F or lower.
- A freezer operates most efficiently when it is at least 2/3 full.

Packaging foods for freezing

- To minimize food dehydration and quality deterioration, use aluminum foil, freezer wrap, freezer bags, or airtight containers. Force as much air out of the packages as possible and seal them tightly. Trapped air can cause food to dry out, change color, and develop an off-flavor (freezer burn).
- Wrap fresh meats and poultry with suitable freezer wrap prior to freezing.
- Do not refreeze meat that has completely thawed.

Loading the freezer

- Avoid adding too much warm food to the freezer at one time. This overloads the freezer, slows the rate of freezing, and can raise the temperature of frozen foods.
- Leave a space between packages, so cold air can circulate freely, allowing food to freeze as quickly as possible.

8.2 Ideas for energy saving

Installation

- Locate the refrigerator in the coolest part of the room, out of direct sunlight, and away from heating ducts or registers.
- Do not place the refrigerator next to heat-producing appliances such as a range, oven, or dishwasher. If this is not possible, a section of cabinetry or an added layer of insulation between the two appliances will help the refrigerator operate more efficiently.

- Level the refrigerator so that the doors close tightly.

Temperature setting

- Refer to Controls and Settings for procedures on temperature settings.

Food storage

- Avoid overcrowding the refrigerator or blocking cold air vents. Doing so causes the refrigerator to run longer and use more energy.
- Cover foods and wipe containers dry before placing them in the refrigerator. This cuts down on moisture build-up inside the unit.
- Organize the refrigerator to reduce door openings. Remove as many items as needed at one time and close the door as soon as possible.
- Do not place a hot container directly on a cold shelf. Remember, such an extreme temperature change may damage the glass.

9. WATER SUPPLY CONNECTION

9.1 Before Installing The Water Supply Line

(some models)

NOTE

Automatic ice makers are optional accessories that you may install in most models at any time. Visit Frigidaire.com for information about Ice Maker Kit IM1900MD.

WARNING!

To avoid electric shock, which can cause death or severe personal injury, disconnect the appliance from the electrical power before connecting a water supply line to the appliance. Connect the appliance to the potable water supply.

IMPORTANT

Ensure your water supply line connections comply with all local plumbing codes.

CAUTION!

To avoid property damage:

- Use stainless steel braided tubing for the water supply line. Do not use water supply tubing made of 1/4" plastic. Plastic tubing greatly increases the potential for water leaks, and the manufacturer will not be responsible for any damage if you use plastic tubing for the supply line.
- Do not install water supply tubing in areas where temperatures fall below freezing.
- Chemicals from a malfunctioning softener can damage the ice maker. If the ice maker is connected to soft water, ensure that the softener is maintained and working properly.

9.2 You will need

- Basic tools: adjustable wrench, flat-blade screwdriver, and Phillips™ screwdriver.

- Access to a household cold water line with water pressure between 30 and 100 psi.
- A water supply line made of stainless steel tubing. To determine the length of tubing needed, measure the distance from the ice maker inlet valve at the back of the appliance to your cold water pipe. Then add approximately 6 ft (1.8 m) to ensure you can move the appliance for cleaning.
- A shutoff valve to connect the water supply line to your household water system. Do not use a self-piercing type shutoff valve.
- Do not reuse compression fitting or use thread seal tape.

NOTE

Check with your local building authority for recommendations on water lines and associated materials prior to installing your new refrigerator. Depending on your local/state building codes, Frigidaire recommends:

- for homes with existing valves its Smart Choice® water line kit 5304437642 with a 6 ft stainless steel water line.
- for homes without an existing valve, we recommend Smart Choice® water line kit 5304493869 with a 6 ft polyline waterline.

Please refer to Frigidaire.com for more information.

9.3 Installing the water supply line

NOTE

These instructions do not cover after market ice maker installation. Instructions in after market ice maker kit should be used.

To connect water supply line to ice maker inlet valve:

1. Disconnect the appliance from electric power source.
2. Place end of water supply line into sink or bucket. Turn on water supply and flush supply line until water is clear. Turn off water supply at shutoff valve.
3. Remove plastic cap from water valve inlet and discard cap.
4. Depending on the tubing you use:

- Copper tubing - Slide brass compression nut, then ferrule (sleeve) onto water supply line. Push water supply line into water valve inlet as far as it will go (1/4" / 6.4 mm). Slide ferrule (sleeve) into valve inlet and finger tighten compression nut onto valve. Tighten another half turn with a wrench; do not over tighten.
- Braided flexible stainless steel tubing - The nut is already assembled on the tubing. Slide nut onto valve inlet and finger tighten nut onto valve. Tighten another half turn with a wrench; do not over tighten.

5. With steel clamp and screw, secure water supply line to rear panel of the appliance.
6. Coil excess water supply line (copper tubing only), about 2.5 turns, behind the appliance as shown and arrange coils so they do not vibrate or wear against any other surface. Do not kink tubing.
7. Turn on water supply at shutoff valve and tighten any connections that leak.
8. Reconnect the appliance to electrical power source.
9. Turn the ice maker on.

Copper tubing installation

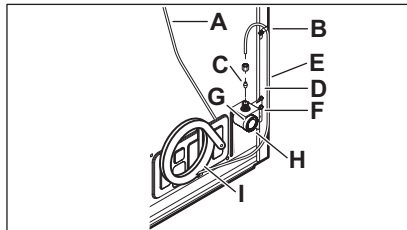

Braided flexible stainless steel tubing installation

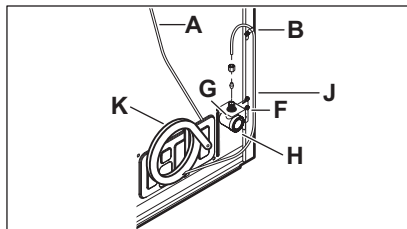

- A. Plastic water tubing to ice maker fill tube
- B. Clamp

- C. Brass compression nut
- D. Ferrule (sleeve)
- E. Copper water line
- F. Water valve bracket
- G. Valve inlet
- H. Water valve
- I. Copper water line from household water supply*

- J. Braided flexible stainless steel water line
- K. 6 ft (1.8 m) braided flexible stainless steel water line from household water supply*

*Include enough tubing in the loop to allow moving the appliance out for cleaning.

10. NORMAL OPERATING SOUNDS

10.1 Understanding the sounds you may hear

- **Evaporator:** Refrigerant flows through the evaporator, making a boiling or gurgling sound.
- **Evaporator fan:** Moves air through the appliance, creating a blowing sound.
- **Defrost heater:** During defrost cycles, water dripping onto the defrost heater causes a hissing or sizzling sound. After defrosting, a popping sound occurs.
- **Automatic ice maker:** Ice cubes drop into the bin, making a sound during each cycle.

- **Compressor:** Runs with a humming or pulsating sound.
- **Water valve:** Opens to fill the ice maker, making a brief buzzing sound. Automatic ice maker makes a buzzing sound as the water valve opens to fill the ice maker during each cycle.
- **Drain pan (not removable):** Water drips into the drain pan during defrost, making a sound.
- **Condenser:** Air moves across the condenser, making an airflow sound.

11. CARE AND CLEANING

11.1 Protecting your investment

Keeping your appliance clean maintains its appearance and prevents odor build-up. Wipe up any spills immediately and clean the appliance and fresh food compartments at least twice a year. When cleaning, take the following precautions:

- Never use chloride or cleaners with bleach to clean stainless steel.
- Do not wash any removable parts in a dishwasher.
- Always unplug the electrical power cord from the wall outlet before cleaning.
- Do not remove the serial plate. Removal of your serial plate voids your warranty.
- Remove adhesive labels by hand. Do not use razor blades or other sharp instruments which can scratch the appliance surface.

Do not use abrasive cleaners such as window sprays, scouring cleansers, brushes, flammable fluids, cleaning waxes, concentrated detergents, bleaches

or cleansers containing petroleum products on plastic parts, interior doors, gaskets or cabinet liners. Do not use paper towels, metallic scouring pads, or other abrasive cleaning materials or strong alkaline solutions.

Refer to the guide below for more details on caring and cleaning specific areas of your appliance.

CAUTION!

Pull the appliance straight out to move it. Shifting it from side to side may damage flooring.

Be careful not to move the appliance beyond the plumbing connections.

IMPORTANT

If you store or move your appliance in freezing temperatures, be sure to completely drain the water supply system. Failure to do so could result in water leaks when the appliance is put back into service. Contact a service representative to perform this operation.

11.2 Cleaning

Before cleaning remove food from the appliance and store it well covered.

Clean the appliance interior and accessories regularly with a cloth and lukewarm water.

Do not use abrasive cleaners. After cleaning rinse with fresh water and dry thoroughly with a clean cloth.

CAUTION!

Unplug the appliance from the power source before cleaning to avoid electrical hazard. Never clean the appliance with a steam cleaner. Allow the appliance to dry before using it.

IMPORTANT

Do not use organic solvents, such as lemon juice, juice from an orange peel, butyric acid, or cleaners containing acetic acid.

11.3 Vacation and moving tips

Short vacations

- Leave the appliance operating during vacations of three weeks or less.
- Use all perishable items from the appliance compartment.
- Turn automatic ice maker off and empty ice bucket, even if you will only be gone a few days.

Long vacation

- Remove all food and ice if you will be gone one month or more.
- Unplug the appliance.
- Turn water supply valve to closed position.
- Clean interior thoroughly.
- Leave both doors open to prevent odors and mold build-up. Block doors open if necessary.

Moving

- Unplug the appliance
- Remove all food and ice.
- Recommend use of a handcart, load from the side.
- Adjust rollers all the way up to protect them during sliding or moving.
- Pad cabinet to avoid scratching surface.

12. TROUBLESHOOTING

Let us help you troubleshoot your concern! This section will help you with common issues. If you need us, visit our website, chat with an agent, or call us. We may be able to help you avoid a service visit. If you do need service, we can get that started for you! Visit Frigidaire.com or call toll-free 1-800-374-4432.

12.1 Common occurrences

The appliance does not run.

- Ensure the plug is tightly pushed into an electrical outlet.
- Check/replace the fuse with a 15amp time-delay fuse. Reset the circuit breaker.
- The appliance may be in defrost cycle. Wait 20 minutes and check again.

The appliance temperature is unsatisfactory.	<ul style="list-style-type: none"> Set the appliance control to a warmer or colder setting until the temperature is satisfactory. Allow 24 hours for the temperature to stabilize.
The appliance is noisy or vibrates.	<ul style="list-style-type: none"> The cabinet is not level. Floor is weak. Refer to Normal Operating Sounds.
Odors in the appliance.	<ul style="list-style-type: none"> The interior needs to be cleaned. Cover or wrap the foods that produce odors.
Cabinet light is not working.	<ul style="list-style-type: none"> Ensure the plug is tightly pushed into an electrical outlet. The light switch may be stuck. Push in the light switch, located on the refrigerator side wall, to release.
Automatic ice maker is not working (some models)	<ul style="list-style-type: none"> Ensure the ice maker is on. The ice maker should produce about 2.5 pounds of ice in a 24 hour period. Ensure the water supply is turned on. The water pressure may be too low. The freezer may not be cold enough.
Ice Maker is not making enough ice (some models)	Set the freezer control to a colder setting to improve the performance of the ice maker. Allow 24 hours for the temperature to stabilize.
Mullion or side walls of the appliance are warm.	Mullion or side walls of the appliance may be warm to the touch for the first 24 hours of operation. This is normal.

13. LIMITED WARRANTY

Your appliance is covered by a one year limited warranty. For one year from your date of delivery, Electrolux will pay all costs for repairing or replacing any parts of this appliance that prove to be defective in materials or workmanship when such appliance is installed, used and maintained in accordance with the provided instructions.

Exclusions

This warranty does not cover the following:

- Products with original serial numbers that have been removed, altered or cannot be readily determined.
- Product that has been transferred from its original owner to another party or removed outside the USA, Puerto Rico, or Canada.
- Rust on the interior or exterior of the unit.
- Products purchased "as-is" are not covered by this warranty.
- Food loss due to any refrigerator or freezer failures.
- Products used in a commercial setting.
- Service calls which do not involve malfunction or defects in materials or workmanship, or for appliances not in ordinary household use or used other than in accordance with the provided instructions.
- Service calls to correct the installation of your appliance or to instruct you how to use your appliance.
- Expenses for making the appliance accessible for servicing, such as removal of trim, cupboards, shelves, etc., which are not a part of the appliance when it is shipped from the factory.
- Service calls to repair or replace appliance light bulbs, air filters, water filters, other consumables, or knobs, handles, or other cosmetic parts.
- Surcharges including, but not limited to, any after hour, weekend, or holiday

service calls, tolls, ferry trip charges, or mileage expense for service calls to remote areas, including the state of Alaska.

12. Damages to the finish of appliance or home incurred during transportation or installation, including but not limited to floors, cabinets, walls, etc.
13. Damages caused by: services performed by unauthorized service companies; use of parts other than genuine Electrolux parts or parts obtained from persons other than authorized service companies; or external causes such as abuse, misuse, inadequate power supply, accidents, fires, or acts of God.

DISCLAIMER OF IMPLIED WARRANTIES; LIMITATION OF REMEDIES

CUSTOMER'S SOLE AND EXCLUSIVE REMEDY UNDER THIS LIMITED WARRANTY SHALL BE PRODUCT REPAIR OR REPLACEMENT AS PROVIDED HEREIN. CLAIMS BASED ON IMPLIED WARRANTIES, INCLUDING WARRANTIES OF MERCHANTABILITY OR FITNESS FOR A PARTICULAR PURPOSE, ARE LIMITED TO ONE YEAR OR THE SHORTEST PERIOD ALLOWED BY LAW, BUT NOT LESS THAN ONE YEAR. ELECTROLUX SHALL NOT BE LIABLE FOR CONSEQUENTIAL OR INCIDENTAL DAMAGES SUCH AS PROPERTY DAMAGE AND INCIDENTAL EXPENSES RESULTING FROM ANY BREACH OF THIS WRITTEN LIMITED WARRANTY OR ANY IMPLIED WARRANTY. SOME STATES AND PROVINCES DO NOT ALLOW THE EXCLUSION OR LIMITATION OF INCIDENTAL OR CONSEQUENTIAL DAMAGES, OR LIMITATIONS ON THE DURATION OF IMPLIED WARRANTIES, SO THESE LIMITATIONS OR

EXCLUSIONS MAY NOT APPLY TO YOU. THIS WRITTEN WARRANTY GIVES YOU SPECIFIC LEGAL RIGHTS. YOU MAY ALSO HAVE OTHER RIGHTS THAT VARY FROM STATE TO STATE.

If You Need Service

Keep your receipt, delivery slip, or some other appropriate payment record to establish the warranty period should service be required. If service is performed, it is in your best interest to obtain and keep all receipts. Service under this warranty must be obtained by contacting Electrolux at the addresses or phone numbers below.

This warranty only applies in the USA, Puerto Rico and Canada. In the USA and Puerto Rico, your appliance is warranted by Electrolux Consumer Products, Inc. In Canada, your appliance is warranted by Electrolux Canada Corp. Electrolux authorizes no person to change or add to any obligations under this warranty. Obligations for service and parts under this warranty must be performed by Electrolux or an authorized service company. Product features or specifications as described or illustrated are subject to change without notice.

USA

1-800-374-4432

Electrolux Consumer Products, Inc.
10200 David Taylor Drive
Charlotte, NC 28262

Canada

1-800-265-8352

Electrolux Canada Corp.
5855 Terry Fox Way
Mississauga, Ontario, Canada L5V 3E4

14. QUEBEC RIGHT TO REPAIR

Though Frigidaire makes every effort to make replacement parts, repair services and information necessary to maintain or repair our products available to consumers, parts, service and information are not guaranteed, pursuant to section 39 of the Consumer Protection Act, CQLR, c. P-40.1 and sections 79.18 to 79.20 of the

Regulation respecting the application of the Consumer Protection Act, CQLR, c. P-40.1, r. 3. If you need replacement parts, you may call us at 1 (800) 265-8352 for service in French or English, or purchase online at **Frigidaire Parts | Shop Frigidaire Replacement Parts &**

Accessories - Frigidaire Appliance Parts.

You may book repair services online at [information](#) | [Book a service](#) | [Frigidaire](#). Alternatively, our resource library is available at **Resource Library | Frigidaire** to help you diagnose and resolve issues which may arise during the lifetime of your appliance.

Though most parts are available for purchase, subject to short-term availability constraints, the following appliances and parts are not serviceable.

Legend

Availability of replacement parts, repair services, and information for maintenance or repair.



Partially Available

Availability of replacement parts, repair services, and information for maintenance or repair.



Not Available



Available

Refrigerators



Cabinet, 14cu ft and less no sealed system parts

Freezer



9 cu. ft and less no sealed system parts.

Beverage Centers



Only cosmetic parts available



