

EN User Manual | Fridge Freezer



Welcome to our family

Thank you for bringing Frigidaire into your home! We see your purchase as the beginning of a long relationship together.

This manual is your resource for the use and care of your product. Please read it before using your appliance. Keep it handy for quick reference. If something doesn't seem right, the troubleshooting section will help you with common issues.

FAQ, helpful tips and videos, cleaning products, and kitchen and home accessories are available at <http://www.frigidaire.com>.

We are here for you! Visit our website, chat with an agent, or call us if you need help. We may be able to help you avoid a service visit. If you do need service, we can get that started for you.

Let's make it official! Be sure to register your product.

CONTENTS

1. IMPORTANT SAFETY INFORMATION.....	2
2. FEATURES	5
3. INSTALLATION	6
4. DOOR REMOVAL	8
5. DOOR HANDLE INSTALLATION	10
6. IN-DOOR USER INTERFACE	11
7. STORAGE FEATURES	12
8. NORMAL OPERATING SOUNDS	13
9. FILTER REPLACEMENT	13
10. CARE AND CLEANING	14
11. TROUBLESHOOTING.....	17
12. LIMITED WARRANTY.....	19

1. IMPORTANT SAFETY INFORMATION

1.1 Keep a record for quick reference

Model number

.....

Serial number

.....

Purchase date

.....

1.2 Serial number location

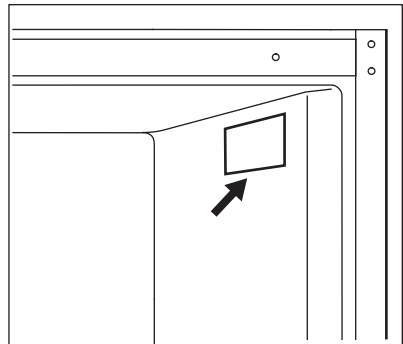

 **WARNING!**

You must follow these guidelines to ensure that your refrigerator's safety mechanisms are operating correctly.

1.3 Safety definitions



This is the safety alert symbol. It is used to alert of potential personal injury hazards. Obey all safety messages that follow this symbol to avoid possible injury or death.

 **DANGER**

DANGER indicates an imminently hazardous situation which, if not avoided, will result in death or serious injury.

 **WARNING!**

WARNING indicates a potentially hazardous situation which, if not avoided, could result in death or serious injury.

 **CAUTION!**

CAUTION indicates a potentially hazardous situation which, if not avoided, may result in minor or moderate injury.

 **IMPORTANT**

IMPORTANT indicates installation, operation or maintenance information which is important but not hazard-related.

 **DANGER**



DANGER Risk of fire or explosion. Flammable refrigerant used. Do not use mechanical devices to defrost refrigerator. Do not puncture refrigerant tubing.

DANGER Risk of fire or explosion. Flammable refrigerant used. To be repaired only by trained service personnel. Use only manufacturer-authorized service parts. Any repair equipment used must be designed for flammable refrigerants. Follow all manufacturer repair instructions. Do not puncture refrigerant tubing.

 **CAUTION!**



CAUTION Risk of fire or explosion. Dispose of refrigerator properly in accordance with the applicable federal or local regulations. Flammable refrigerant used. CAUTION Risk of fire or explosion due to puncture of refrigerant tubing. Follow handling instructions carefully. Flammable refrigerant used.

 **WARNING!**

CALIFORNIA RESIDENTS ONLY
WARNING! Cancer and Reproductive Harm <http://www.P65Warnings.ca.gov>

1.4 Child safety

This appliance is not intended for use by persons (including children) with reduced physical, sensory or mental capabilities, or lack of experience and knowledge, unless they have been given supervision or instruction concerning use of the appliance by a person responsible for their safety.

Destroy or recycle the carton, plastic bags, and any exterior

wrapping material immediately after the refrigerator is unpacked. Children should never use these items to play. Cartons covered with rugs, bedspreads, plastic sheets or stretch wrap may become airtight chambers, and can quickly cause suffocation.

1.5 Important safety instructions

Do not store or use gasoline or other flammable vapors and liquids in the vicinity of this or any other appliance.

Do not store explosive substances such as aerosol cans with a flammable propellant in this appliance.

Do not operate the refrigerator in the presence of explosive fumes. Avoid contact with any moving parts of automatic ice maker.

Remove all staples from the carton. Staples can cause severe cuts, and also destroy finishes if they come in contact with other appliances or furniture.

WARNING!

Do not use electrical appliances inside the food storage compartments of the appliance unless they are of the type recommended by the manufacturer.

1.6 Proper disposal of your refrigerator or freezer

Risk of child entrapment

Child entrapment and suffocation are not problems of the past. Junked or abandoned refrigerators or freezers are still dangerous – even if they will sit for “just a few

days”. If you are getting rid of your old refrigerator or freezer, follow the instructions below to help prevent accidents.

We strongly encourage responsible appliance recycling/disposal methods. Check with your utility company or visit <http://www.energystar.gov/recycle> for more information on recycling your old refrigerator.

Before you throw away your old refrigerator/freezer:

- Remove doors.
- Leave shelves in place so children may not easily climb inside.
- Have it removed by a qualified service technician.

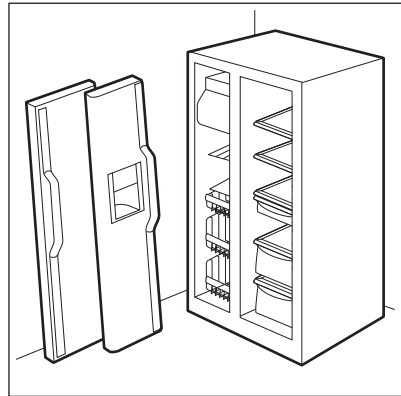

1.7 Electrical information

- The appliance must be plugged into its own dedicated 115 Volt, 60 Hz., 15 Amp, AC only electrical outlet. The power cord of the appliance is equipped with a three-prong grounding plug for your protection against electrical shock hazards. It must be plugged directly into a properly grounded three-prong receptacle. The receptacle must be installed in accordance with local codes and ordinances. Consult a qualified electrician. Do not use an extension cord or adapter plug.

⚠ WARNING!

Avoid fire hazard or electric shock.

- If the power cord is damaged, it should be replaced by an authorized service technician to prevent any risk.
- Never unplug the appliance by pulling on the power cord. Always grip the plug firmly, and pull straight out from the receptacle to prevent damaging the power cord.
- Unplug the appliance before cleaning and before replacing the AC LED light bulb to avoid electrical shock. Use only a 5-watt or less AC LED light bulb.
- Performance may be affected if the voltage varies by 10% or more. Operating the appliance with insufficient power can damage the compressor. Such damage is not covered under your warranty.
- Do not plug the unit into an electrical outlet controlled by a wall switch or pull cord to prevent the appliance from being turned off accidentally.

- Do not pinch, knot, or bend the power cord in any manner.

⚠ WARNING!

When positioning the appliance, ensure the supply cord is not trapped or damaged.

Do not locate multiple portable socket-outlets or portable power supplies at the rear of the appliance.

⚠ WARNING!

Do not, under any circumstances, cut, remove, or bypass the grounding prong (A). Always use the power cord with a three-prong grounded plug and grounding type wall receptacle.

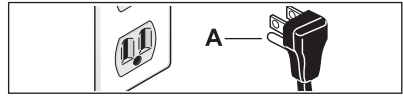

2. FEATURES

▶ IMPORTANT

Features may vary by model.

Accessories are available for your appliance and may be purchased at Frigidaire.com or by calling toll-free 1-866-831-2306.

2.1 Product overview

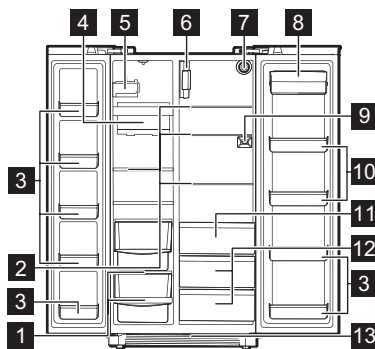

1 Basket

- 2 Shelves
- 3 Fixed Door Bins
- 4 Ice Container
- 5 Ice Maker
- 6 Damper/Air filter housing
- 7 Water Filter
- 8 Dairy Compartment
- 9 Temperature Sensor/Thermistor
- 10 Adjustable Door Bins
- 11 Deli Drawer (some models)
- 12 Crisper Pan
- 13 Toe Grille

3. INSTALLATION

This User Manual provides general installation and operating instructions for your model. We recommend using a service or kitchen contracting professional to install your appliance. Use the appliance only as instructed in this User Manual. Before starting the appliance, follow these important first steps.

3.1 ✓ Installation Checklist

Doors

- Door seals completely the cabinet on all sides
- Doors are level with each other

Leveling

- Appliance is level side-to-side and tilted 1/4" (6mm) front-to-back
- Cabinet is setting solid on all corners
- Toe grille is properly attached

Electrical Power

- House power is turned on
- Appliance is plugged in

Final Checks

- Shipping material is removed
- Refrigerator and freezer temperatures are set
- Registration card is sent in

3.2 Tools necessary

These tools are necessary at different stages of the installation process:

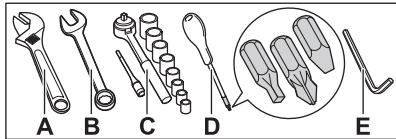

- A. Adjustable Wrench
- B. 3/8" Fixed Wrench
- C. Socket Wrench
- D. Screwdriver: Phillips™ Head and Flat Head
- E. 6mm Allen Wrench

Components Provided

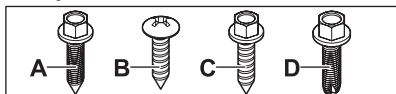

- A. Top hinge screw
- B. Top hinge cover front screw
- C. Top hinge cover rear screw
- D. Lower hinge screw

3.3 Location

- If possible, place the appliance out of direct sunlight and away from the range, dishwasher, or other heat sources.
- The appliance must be installed on a floor that is level and strong enough to support a fully loaded appliance.

⚠ WARNING!

This appliance is intended for use in residential household and similar interior applications such as:

- Kitchen / kitchenette
- Pantry room
- Basement
- Enclosed garage
- Other interior residential type environments

🚫 IMPORTANT

This appliance is garage-ready. It is designed to operate in ambient temperatures between 45°F (7°C) and 110°F (43°C).

⚠ CAUTION!

Do not install the appliance where the temperature will drop below 45°F (7°C) or rise above 110°F (43°C). The compressor will not be able to maintain proper temperatures inside the appliance.

🚫 NOTE

Do not block the toe grille on the lower front of the appliance. Sufficient air circulation is essential for the proper operation of the appliance.

⚠ WARNING!

Allow the following clearances for ease of installation, proper air circulation, plumbing, and electrical connections:

- Top 3/8" (9.5mm)
- Sides 3/8" (9.5mm)
- Back 1" (25.4mm)

NOTE

If you place the appliance with the door hinge side against a wall, you may have to allow additional space so the door can be open wider.

3.4 Door opening

NOTE

The doors are designed to shut by themselves within a 20° opening.

Position the appliance to allow easy access to a counter when removing food. Make sure the refrigerator drawers and freezer baskets can be fully open.

3.5 Cabinet leveling and door alignment

Guidelines for final positioning of appliance:

- All 4 corners of the cabinet must rest firmly on the floor.
- The cabinet should be level at the front and rear.
- The sides should tilt 1/4" (6mm) from front to back to ensure that doors close and seal properly.
- Align the doors with each other and level them.

You can meet most of these conditions by raising or lowering the adjustable front feet.

3.6 Toe Grille Installation and Removal

Installing the toe grille:

1. Open both doors. Slide the left and right sides of toe grille over the lower hinges of the appliance.
2. While pushing the toe grille firmly against cabinet, fasten the bottom clips of toe grille to the cabinet.
3. Fasten the top clips to the cabinet.
4. Close the doors. Fasten the right and left side clips into the groove of the bottom hinge.

Installing toe grille

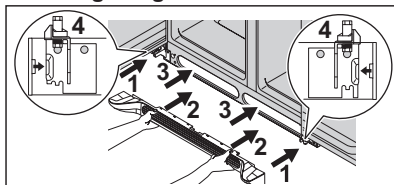

Removing the toe grille:

1. With both doors closed, unfasten the right and left side clips of toe grille from the bottom hinge groove.
2. Open both doors. Press firmly on the top of the toe grille until the top of the toe grille pops off.
3. Pull the toe grille outward toward your body and off of the lower hinges.

Removing toe grille

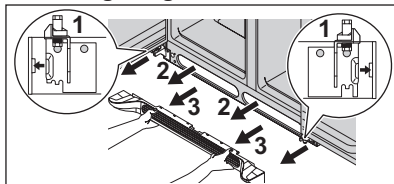

3.7 Leveling feet

To level the cabinet using the front leveling feet:

1. Open both doors and remove the toe grille (refer to Toe Grille Installation and Removal in the Installation).
2. Level the cabinet at the front and rear so the front is raised 1/4"(6mm) above the rear. Close the doors. Use an adjustable wrench to loosen the feet (A). Once you have lowered the leveling feet slightly, use the wrench on the nut (B) to lower (counterclockwise) or raise (clockwise) the front of the cabinet ensuring the unit is sitting flat on the floor.

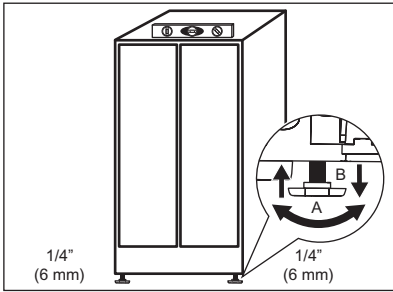

3. Ensure both doors are bind free with their seals touching the cabinet on all 4 sides.

3.8 Leveling doors

To level the doors using the adjustable lower hinge:

1. Before leveling either door, remove the set screw that locks the door height into position using a 3/32 hex key.

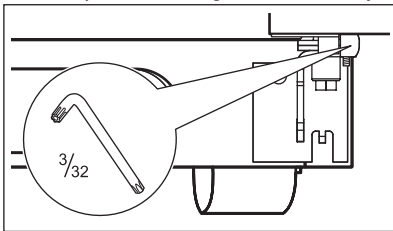

2. If the freezer door is lower than the refrigerator door (A) or the refrigerator door is lower than the freezer door (B),

raise the door by turning the adjustment screw clockwise using a 10mm wrench.

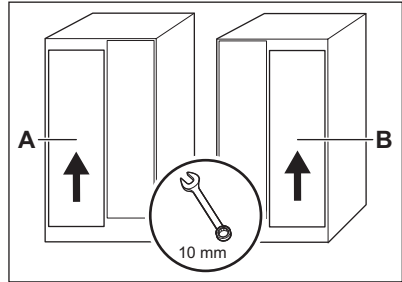

3. After leveling, verify the door stop contacts the lower hinge and the top of the door does not contact the upper hinge through full movement of the door (from fully closed to fully open).

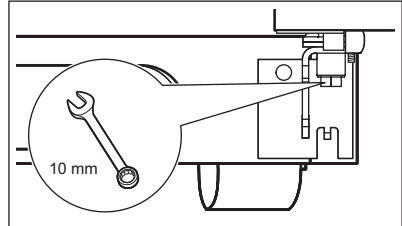

4. Reinstall the set screw, locking the door height.
5. Replace the toe grille by fitting it into place (refer to Toe Grille Installation and Removal in the Installation).

4. DOOR REMOVAL

4.1 Preparing for Door Removal

To prepare for removing the doors:

1. Make sure the electrical power cord is unplugged from the wall outlet.
2. Open both doors and remove the toe grille (as explained in the Toe Grille Installation and Removal in the Installation section).
3. Remove any food from the door shelves.
4. Close the doors.

4.2 Removing the Refrigerator Door

To remove the refrigerator top hinge/cover:

1. Remove the 3 screws from the cover over the top door hinge.
2. Lift hinge cover straight up and off.
3. Trace lightly around the door's top hinge with a pencil. This makes reinstallation easier.
4. Remove the 2 screws from the top hinge and lift the hinge straight up. Lift the door off the bottom hinge and set it aside.
5. Remove the 2 bottom hinge screws and hinge if necessary.

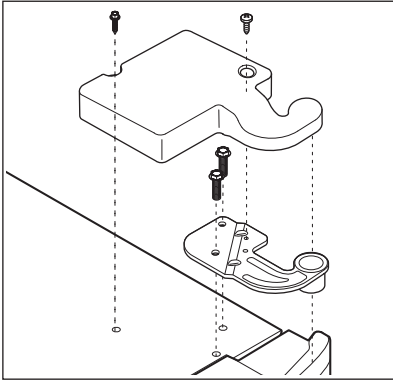

Adjustable Hinge

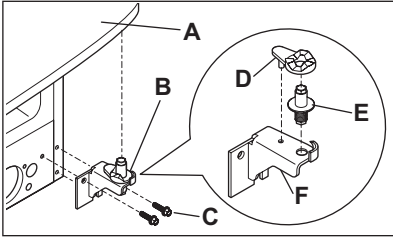

- A. Door
- B. Hinge Assembly
- C. Screws
- D. Closer
- E. Pin
- F. Hinge

To reinstall the refrigerator door, reverse the above steps.

4.3 Removing the Freezer Door

To remove the freezer top hinge cover:

1. Remove the 3 screws from the cover over the top door hinge.
2. Lift hinge cover straight up and off.

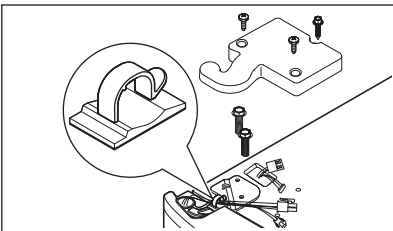

To remove the freezer door:

1. Release the wires from the routing clip.

IMPORTANT

To prevent wire damage ensure the wires are rerouted through the routing clip when reassembling the hinge cover.

2. Disconnect the 2 multi-wire cable connectors located above the top hinge. Grasp both sides of the connector firmly, press the connector lock and pull apart. Remove the ground screw.

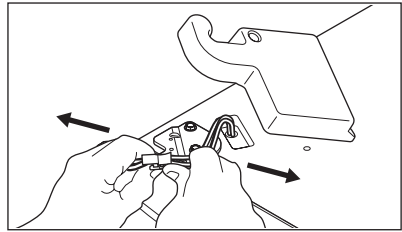

3. Trace lightly around the hinge with a pencil. This makes reinstallation easier.
4. Remove the 2 screws from the top hinge and lift the hinge straight up, pulling the 2 multi-wire cables through it. Lift the door off of the bottom hinge.
5. Remove the 2 bottom hinge screws and hinge if necessary.
6. Lay the door on its side.

To reinstall the freezer door, reverse the above steps.

CAUTION!

Make sure doors are set aside in a secure position where they cannot fall and cause personal injury.

5. DOOR HANDLE INSTALLATION

CAUTION!

Wear gloves and safety goggles. Use extreme caution when installing these handles.

The rounded end of the handles may be sharp (some models).

IMPORTANT

To ensure proper installation of handles, please review these instructions and illustrations thoroughly prior to installing the handles.

5.1 Door handle installation

To install the door handle:

1. Remove the handles and any other protective packaging from the carton.
2. Position the handle end caps over upper and lower preinstalled shoulder bolts (A) that are fastened into door, ensuring the holes for the set screws are facing towards the opposite door.
3. While holding handle firmly against door, fasten upper and lower Allen set screws (B) with supplied Allen wrench.

4. Repeat the steps above to install the opposite handle. Ensure the holes for the set screws are facing towards the opposite door.

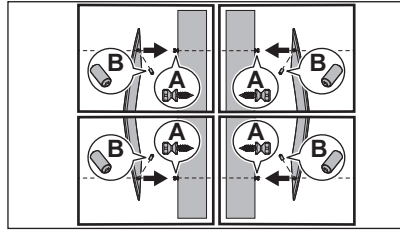

NOTE

Tighten and sub-flush all set screws (place the Allen set screw just below the surface of the end cap) of the handle end cap. Draw the end caps tight to the freezer and refrigerator doors with no gaps. To avoid scratching the metal door, keep the door open while torquing down the set screws.

6. IN-DOOR USER INTERFACE

Temperature Adjustment

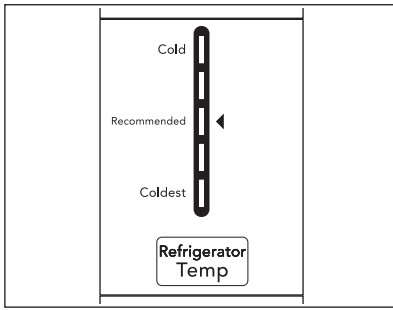
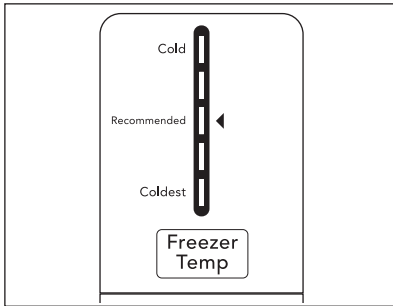

Adjust the temperature gradually: adjust in small increments, allowing the temperature to stabilize.

- For colder temperatures, press Temp to change the temperature setting toward Coldest.
- For warmer temperatures, press Temp to change the temperature setting toward Cold.

Adjusting the refrigerator control changes the temperature in both compartments. The freezer control can be left at the factory preset (*Recommended) or adjusted as desired.

To maintain temperatures, a fan circulates air in the refrigerator and freezer compartments. For good circulation, do not block cold air vents with food items.

Air Filter Status (some models)

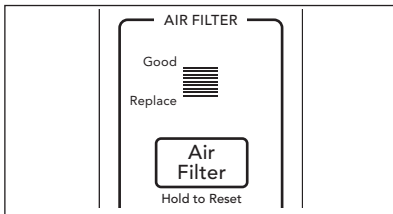

The display shows the current status of the air filter. To reset the filter status to Good, press and hold Air Filter for 3 seconds.

Ordering Filters



Scan the QR code with your mobile device to order replacement filters for your appliance.

In-Door Control Display Mode Views
Your display is equipped with a sleep and inactive mode to prevent accidental changes to the unit settings during

opening and closing of the doors. When both doors are closed, the display is in sleep mode which is signaled by all current settings lights turning off. When

either door is first opened, the display is in inactive mode where all the current settings are visible but dimmed.

Pressing any button on the display activates the display and a tone plays. All

settings are then fully lit. Touch the display again to change any setting.

If you do not press a button for 10 seconds while any door is open, the display defaults back to inactive mode.

7. STORAGE FEATURES

7.1 Glass shelves

Shelves are easily adjusted to suit individual needs. Before adjusting the shelves, remove all food. Shelves are supported by side rails. Refer to Refrigerator Glass Shelves in Care and Cleaning for proper shelf removal.

7.2 Door storage

Door bins and shelves are provided for convenient storage of jars, bottles, and cans. You can quickly select frequently used items.

Some models have door bins that can accommodate gallon-sized plastic drink containers and economy-sized jars and containers. Some bins are adjustable for maximum storage capacity.

The dairy compartment which is warmer than the general food storage section, is intended for short term storage of cheese, spreads, or butter.

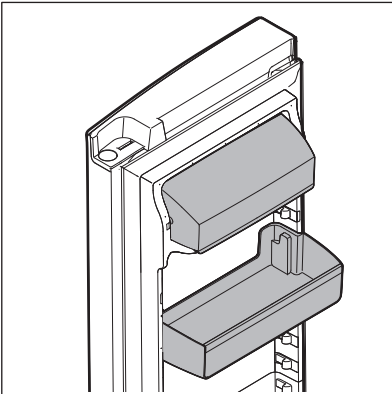

7.3 Crispers

Crispers allow you the flexibility to store any manner of items including fruits, vegetables, nuts, etc. Crispers do not feature humidity controls.

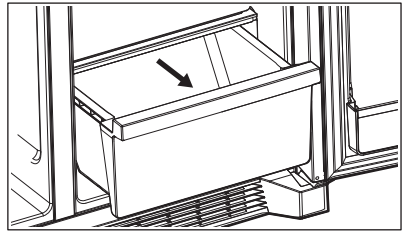

7.4 Deli Drawer (some models)

Some models are equipped with a deli drawer for storing luncheon meats, spreads, cheeses and other deli items. This drawer does not have a separate temperature control.

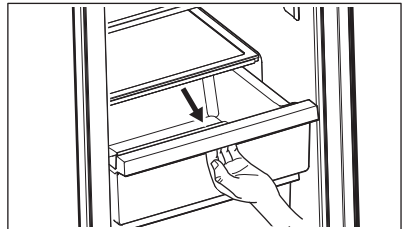

8. NORMAL OPERATING SOUNDS

8.1 Understanding the sounds you may hear

Your new, high-efficiency appliance may introduce unfamiliar sounds. These sounds normally indicate your appliance is operating correctly. Some surfaces on floors, walls, and kitchen cabinets may make these sounds more noticeable.

NOTE

Energy efficient foam in your appliance is not a sound insulator.

Following is a list of major components in your appliance and the sounds they can cause:

- A. Evaporator. Refrigerant through the evaporator may create a boiling or gurgling sound.
- B. Evaporator fan. You may hear air being forced through the refrigerator by the evaporator fan.
- C. Defrost heater. During defrost cycles, water dripping onto the defrost heater may cause a hissing or sizzling sound. After defrosting, a popping sound may occur.
- D. Ice maker. When ice has been produced, you will hear ice cubes falling into the ice bin.
- E. Compressor. Modern, high-efficiency compressors run much faster than previous models. The compressor may have a noticeable hum or pulsating sound during operation.
- F. Water valve. Makes a buzzing sound each time it opens to fill the ice maker.
- G. Drain pan (not removable). You may hear water dripping into the drain pan during the defrost cycle.

- H. Motorized damper. May produce intermittent humming during operation.

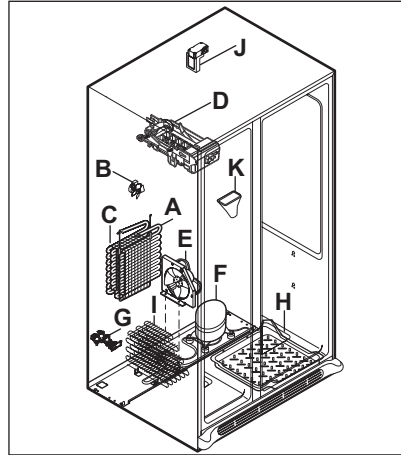

NOTE

During automatic defrost cycle, a red glow in the back wall vents of your freezer compartment is normal.

NOTE

Today's refrigerators are designed with a variable speed compressor to be more energy efficient than previous models. This means your compressor reacts quickly to temperature fluctuations and circulates cold air based off your use and room temperature.

9. FILTER REPLACEMENT

9.1 PureAir Ultra II™ Air Filter

Your appliance control display is equipped with a Replace Air Filter indicator to remind you to change your filter every 6 months to ensure optimal filtering of appliance odors.

Your PureAir Ultra II™ Air Filter is included in your Literature Pack in the crisper drawer

To order replacement filters, please visit our online store at Frigidaire.com or call toll-free at 1-866-831-2306. Here are the product numbers to request when ordering:

NOTE

We recommend you always use genuine Frigidaire replacement filters only.

9.2 Replacing your air filter

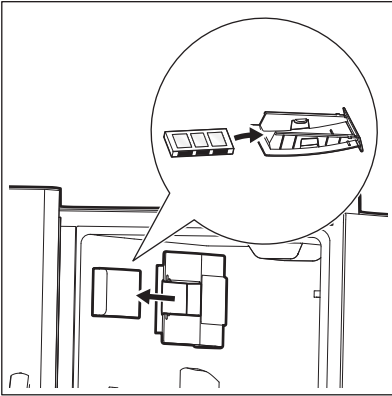

You should change your air filter every 6 months (the filter status light on the control panel prompts you to replace the filter after 6 months) to optimize the reduction of refrigerator odors. Different foods will emit various levels of odor. To install your new PureAir Ultra II™ air filter:

1. Pull the air filter housing straight out.
2. Remove the old filter and discard it (if applicable).
3. Unpack the new filter and place it inside the housing.
4. Slide the housing back into position.
5. Activate or reset the Air Filter status light on the control panel.

9.3 Damper/Air Filter Housing

In humid regions certain products stored too close to the damper/air filter housing may freeze. If this scenario occurs, adjust the fresh food temperature settings and reconfigure the top shelf storage to allow for proper air diffusion.

10. CARE AND CLEANING

10.1 Protecting your investment

Keeping your appliance clean maintains its appearance and prevents odor build-up. Wipe up any spills immediately and clean the freezer and fresh food compartments at least twice a year. When cleaning, take the following precautions:

- Never use chloride or cleaners with bleach to clean stainless steel.
- Do not wash any removable parts in a dishwasher.
- Always unplug the electrical power cord from the wall outlet before cleaning.
- Do not remove the serial plate. Removal of your serial plate voids your warranty.
- Remove adhesive labels by hand. Do not use razor blades or other sharp instruments which can scratch the appliance surface.

Do not use abrasive cleaners such as window sprays, scouring cleansers, brushes, flammable fluids, cleaning waxes, concentrated detergents, bleaches or cleansers containing petroleum products on plastic parts, interior doors,

gaskets or cabinet liners. Do not use paper towels, metallic scouring pads, or other abrasive cleaning materials or strong alkaline solutions.

Refer to the guide below for more details on caring and cleaning specific areas of your appliance.

CAUTION!

Pull the appliance straight out to move it. Shifting it from side to side may damage flooring.

CAUTION!

Damp objects stick to cold metal surfaces. Do not touch refrigerated surfaces with wet or damp hands.

Sudden temperature changes can cause glass breakage.

10.2 Replacing the LED Light Bulb

1. Unplug the appliance.

- Wearing gloves, slide the clear light cover along the top of the unit toward the front of the unit.
- Replace the old LED bulb with a bulb no greater than 5Watts.

⚠ CAUTION!

Wear gloves when replacing the LED bulb to avoid getting cut. Use the same wattage when replacing the LED bulb.

- Replace the light cover.
- Plug in the appliance.

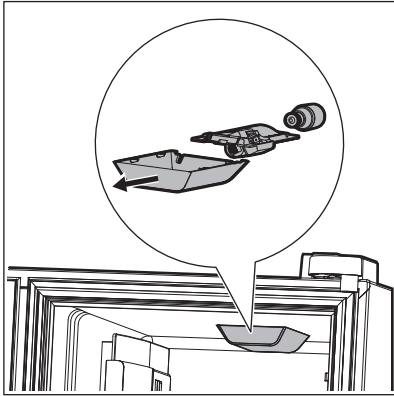

10.3 Refrigerator Glass Shelves

⚠ CAUTION!

To avoid personal injury or property damage, handle tempered glass shelves carefully. Shelves may break suddenly if nicked, scratched, or exposed to sudden temperature change. Allow the glass shelves to stabilize to room temperature before cleaning. Do not wash in the dishwasher.

Refrigerator shelves are easily adjusted to suit individual needs. Before adjusting the shelves, remove all food. Shelves are supported by side rails.

To adjust the refrigerator shelves:

- Lift up on the back of the shelf and pull forward.
- Replace the shelf by sliding it on top of the formed rails on the side walls of the cabinet until the rear plastic hooks of the shelf lock into the rear of the cabinet liner.

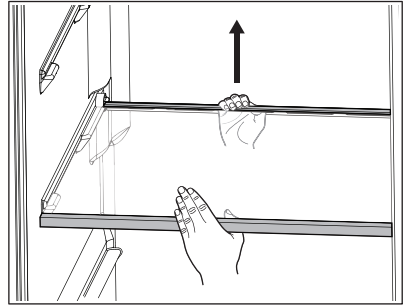

10.4 Freezer Glass Shelves

⚠ CAUTION!

To avoid personal injury or property damage, handle the freezer glass shelves carefully. These shelves are fixed and are not to be used as sliding shelves.

You can remove the glass freezer shelf for cleaning. Before removing the shelf, remove all food from the glass shelf.

To remove the freezer shelf:

- Rotate the front trim down to remove front trim.

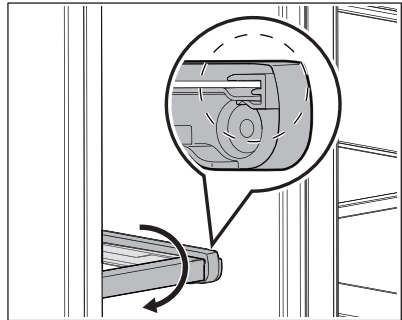

- Remove both the rear trim and glass by pulling up on the rear tab and sliding the shelf forward.

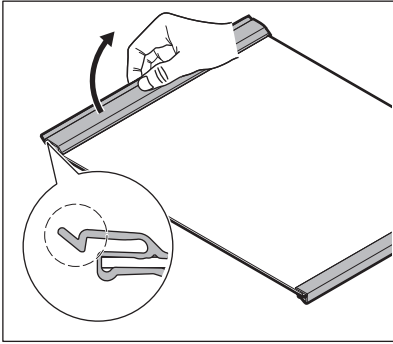

2. Rotate the front trim upward on the front edge of the glass shelf.

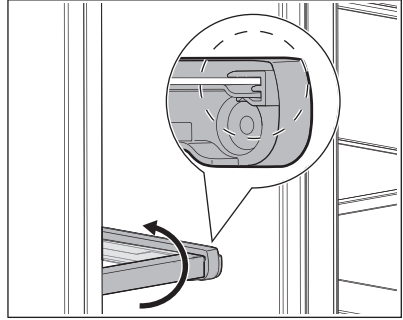

⚠ CAUTION!

Allow the glass shelves to stabilize to room temperature before cleaning. Do not wash in the dishwasher.

To reassemble the freezer shelf:

1. Slide the glass and rear trim along the shelf rails while pressing the shelf downward until it is fully locked into place in the rear.

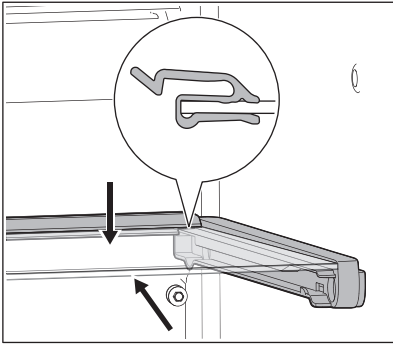

10.5 Care & Cleaning Tips

Part	What to use	Tips and precautions
Interior and door liners	<ul style="list-style-type: none"> • Soap and water • Baking soda and water 	Use 2 tablespoons of baking soda in 1 quart of warm water. Be sure to wring excess water out of sponge or cloth before cleaning around controls, light bulb or any electrical part.
Door gaskets	Soap and water	Wipe gaskets with a clean soft cloth.
Drawers and bins	Soap and water	Use a soft cloth to clean drawer runners and tracks.

Part	What to use	Tips and precautions
Toe grille	<ul style="list-style-type: none"> • Soap and water • Mild liquid sprays • Vacuum attachment 	Vacuum dust from front of toe grille. Remove toe grille (refer to Installation). Vacuum backside, wipe with sudsy cloth or sponge. Rinse and dry.
Exterior	<ul style="list-style-type: none"> • Soap and water 	Never use chloride or cleaners with bleach to clean stainless steel. Always clean, wipe and dry with the grain to prevent scratching. Wash the rest of the cabinet with warm water and mild liquid detergent. Rinse well, and wipe dry with a clean soft cloth.
Replacing LED bulbs	<ol style="list-style-type: none"> 1. Unplug the appliance. 2. Wear gloves. 3. Replace the appliance light cover by sliding the cover forward along the top. 4. Replace old LED bulb. 5. Replace light cover. 6. Plug in the appliance. 	Caution: Wear gloves when replacing LED light bulbs to avoid getting cut. Use same wattage when replacing bulb. Use only a 5-watt or less AC LED light bulb.

11. TROUBLESHOOTING

Let us help you troubleshoot your concern! This section will help you with common issues. If you need us, visit our website, chat with an agent, or call us. We may be able to help you avoid a service visit. If you do need service, we can get that started for you! Visit Frigidaire.com or call toll-free 1-866-831-2306.

Opening/Closing of Doors/Drawers

Concern	Potential cause	Common solution
Door(s) does not close.	Door was closed too hard, causing other door to open slightly.	Close both doors gently.
	Refrigerator is not level. It rocks on the floor when moved slightly.	Ensure floor is level and solid, and can adequately support the refrigerator. Contact a carpenter to correct a sagging or sloping floor.
	Refrigerator is touching a wall or cabinet.	Ensure floor is level and solid, and can adequately support the refrigerator. Contact a carpenter to correct a sagging or sloping floor.
	Food/packaging is obstructing the door from closing.	Make sure there is no food/packaging blocking the doorway.
Drawers are difficult to move.	Food is touching shelf on top of drawer.	Remove top layer of items in drawer.
	Track that drawers slide on is dirty.	<ul style="list-style-type: none"> • Ensure drawer is properly installed on track. • Clean drawer, rollers, and track. Refer to Care and Cleaning.

Running of appliance

Concern	Potential cause	Common solution
Compressor does not run.	The appliance is unplugged.	Ensure plug is tightly pushed into outlet.
	Refrigerator is in defrost cycle.	This is normal for a fully automatic defrost refrigerator. The defrost cycle occurs periodically, lasting about 30 minutes.
	House fuse blown or tripped circuit breaker.	Check/replace fuse with a 15amp time-delay fuse. Reset circuit breaker.
	Power outage.	Check house lights. Call local electric company.
Refrigerator seems to run too much or too long.	Room or outside weather is hot.	It is normal for the refrigerator to work longer under these conditions.
	Doors are opened too frequently or too long.	Warm air entering the refrigerator causes it to run more. Open doors less often.
	Refrigerator/freezer door may be slightly open.	Ensure refrigerator is level. Keep food and containers from blocking door. See the Opening/Closing of Doors/Drawers section above.
	Freezer control is set too cold.	Set refrigerator control to warmer setting until refrigerator temperature is satisfactory. Allow 24 hours for temperature to stabilize.
	Refrigerator/freezer gasket is dirty, worn, cracked, or poorly fitted.	Clean or change gasket. Leaks in door seal will cause refrigerator to run longer in order to maintain desired temperatures.
	Condenser is dirty.	Clean condenser. Refer to Care and Cleaning.
Appliance seems to run continuously.	The appliances are designed with a variable speed compressor to be more energy efficient than previous models. This means your compressor reacts quickly to temperature fluctuations and circulates cold air based off your use and room temperature.	This is normal for a variable speed compressor refrigerator; however, if you have concerns, call toll-free 1-866-831-2306 or visit Frigidaire.com.

Digital temperature display

Concern	Potential cause	Common solution
Digital temperature displays an error.	Electronic control system has detected a performance problem.	Call your Frigidaire service representative, who can interpret any messages or number codes flashing on the digital displays.

Water/Moisture/Frost Inside Refrigerator

Concern	Potential cause	Common solution
Moisture collects on inside of refrigerator walls.	Weather is hot and humid.	The rate of frost buildup and internal sweating increases.
	Flipper mullion	Adjust flipper mullion. Refer to Flipper Mullion in Installation.
	Door is slightly open.	See the Opening/Closing of Doors/Drawers section above.
Water collects on bottom side of drawer cover.	Vegetables contain and give off moisture.	<ul style="list-style-type: none"> It is not unusual to have moisture on the bottom side of the cover. Move humidity control (some models) to lower setting.
Water collects in bottom of drawer.	Washed vegetables and fruit drain while in the drawer.	Water collecting in bottom of drawer is normal. Dry items before putting them in the drawer or store produce in tightly sealed bags to help reduce condensation inside of the drawer.
Stored products on top shelf freeze.	Fresh food temperature setting too cold.	Adjust fresh food temperature settings.
	Certain products stored too close to damper / air filter housing.	Reconfigure top shelf storage to allow proper diffusion of air. Refer to Damper/Air Filter Housing in Filter Replacement.

Water/Moisture/Frost Outside Refrigerator

Concern	Potential cause	Common solution
Moisture collects on outside of refrigerator or between doors.	Weather is humid.	This is normal in humid weather. When humidity is lower, the moisture should disappear.
	Door is slightly open, causing cold air from inside refrigerator to meet warm air from outside.	See the Opening/Closing of Doors/Drawers section above.

12. LIMITED WARRANTY

Your appliance is covered by a one year limited warranty. For one year from your date of delivery, Electrolux will pay all costs for repairing or replacing any parts of this appliance that prove to be defective in materials or workmanship when such appliance is installed, used and maintained in accordance with the provided instructions.

Exclusions

This warranty does not cover the following:

1. Products with original serial numbers that have been removed, altered or cannot be readily determined.
2. Product that has been transferred from its original owner to another party or removed outside the USA or Canada.
3. Rust on the interior or exterior of the unit.
4. Products purchased "as-is" are not covered by this warranty.
5. Food loss due to any refrigerator or freezer failures.
6. Products used in a commercial setting.

7. Service calls which do not involve malfunction or defects in materials or workmanship, or for appliances not in ordinary household use or used other than in accordance with the provided instructions.
8. Service calls to correct the installation of your appliance or to instruct you how to use your appliance.
9. Expenses for making the appliance accessible for servicing, such as removal of trim, cupboards, shelves, etc., which are not a part of the appliance when it is shipped from the factory.
10. Service calls to repair or replace appliance light bulbs, air filters, water filters, other consumables, or knobs, handles, or other cosmetic parts.
11. Surcharges including, but not limited to, any after hour, weekend, or holiday service calls, tolls, ferry trip charges, or mileage expense for service calls to remote areas, including the state of Alaska.
12. Damages to the finish of appliance or home incurred during transportation or installation, including but not limited to floors, cabinets, walls, etc.
13. Damages caused by: services performed by unauthorized service companies; use of parts other than genuine Electrolux parts or parts obtained from persons other than authorized service companies; or external causes such as abuse, misuse, inadequate power supply, accidents, fires, or acts of God.

DISCLAIMER OF IMPLIED WARRANTIES; LIMITATION OF REMEDIES

CUSTOMER'S SOLE AND EXCLUSIVE REMEDY UNDER THIS LIMITED WARRANTY SHALL BE PRODUCT REPAIR OR REPLACEMENT AS PROVIDED HEREIN. CLAIMS BASED ON IMPLIED WARRANTIES, INCLUDING WARRANTIES OF MERCHANTABILITY OR FITNESS FOR A PARTICULAR PURPOSE, ARE LIMITED TO ONE YEAR OR THE SHORTEST PERIOD ALLOWED BY LAW, BUT NOT LESS THAN ONE YEAR. ELECTROLUX SHALL NOT BE LIABLE FOR CONSEQUENTIAL OR INCIDENTAL DAMAGES SUCH AS PROPERTY DAMAGE AND INCIDENTAL EXPENSES RESULTING FROM ANY

BREACH OF THIS WRITTEN LIMITED WARRANTY OR ANY IMPLIED WARRANTY. SOME STATES AND PROVINCES DO NOT ALLOW THE EXCLUSION OR LIMITATION OF INCIDENTAL OR CONSEQUENTIAL DAMAGES, OR LIMITATIONS ON THE DURATION OF IMPLIED WARRANTIES, SO THESE LIMITATIONS OR EXCLUSIONS MAY NOT APPLY TO YOU. THIS WRITTEN WARRANTY GIVES YOU SPECIFIC LEGAL RIGHTS. YOU MAY ALSO HAVE OTHER RIGHTS THAT VARY FROM STATE TO STATE.

If You Need Service

Keep your receipt, delivery slip, or some other appropriate payment record to establish the warranty period should service be required. If service is performed, it is in your best interest to obtain and keep all receipts. Service under this warranty must be obtained by contacting Electrolux at the addresses or phone numbers below.

This warranty only applies in the USA and Canada. In the USA, your appliance is warranted by Electrolux Major Appliances North America, a division of Electrolux Consumer Products, Inc. In Canada, your appliance is warranted by Electrolux Canada Corp. Electrolux authorizes no person to change or add to any obligations under this warranty. Obligations for service and parts under this warranty must be performed by Electrolux or an authorized service company. Product features or specifications as described or illustrated are subject to change without notice.

USA

1-800-374-4432

Frigidaire

10200 David Taylor Drive

Charlotte, NC 28262

Canada

1-800-265-8352

Electrolux Canada Corp.

5855 Terry Fox Way

Mississauga, Ontario, Canada L5V 3E4







