

EN User Manual | Fridge Freezer



Welcome to our family

Thank you for bringing Frigidaire into your home! We see your purchase as the beginning of a long relationship together.

This manual is your resource for the use and care of your product. Please read it before using your appliance. Keep it handy for quick reference. If something doesn't seem right, the troubleshooting section will help you with common issues.

FAQ, helpful tips and videos, cleaning products, and kitchen and home accessories are available at <http://www.frigidaire.com>.

We are here for you! Visit our website, chat with an agent, or call us if you need help. We may be able to help you avoid a service visit. If you do need service, we can get that started for you.

Let's make it official! Be sure to register your product.

CONTENTS

1. IMPORTANT SAFETY INFORMATION.....	2
2. FEATURES.....	5
3. INSTALLATION.....	6
4. CONTROLS AND SETTINGS.....	11
5. STORAGE FEATURES.....	11
6. STORING FOOD AND SAVING ENERGY.....	12
7. NORMAL OPERATING SOUNDS.....	13
8. CARE AND CLEANING.....	14
9. TROUBLESHOOTING.....	15
10. LIMITED WARRANTY.....	18
11. QUEBEC RIGHT TO REPAIR.....	19

1. IMPORTANT SAFETY INFORMATION

1.1 Keep a record for quick reference

Model number

.....

Serial number

.....

Purchase date

.....

1.2 Serial number location

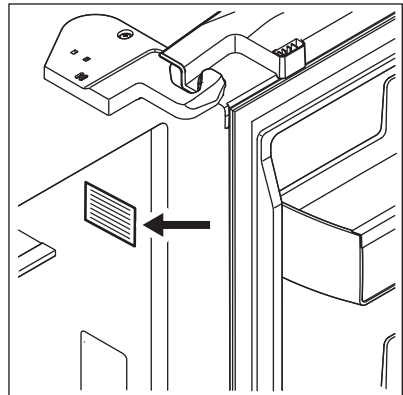

 **WARNING!**

You must follow these guidelines to ensure that your appliance's safety mechanisms are operating correctly.

1.3 Safety definitions



This is the safety alert symbol. It is used to alert of potential personal injury hazards. Obey all safety messages that follow this symbol to avoid possible injury or death.

 **DANGER**

DANGER indicates an imminently hazardous situation which, if not avoided, will result in death or serious injury.

 **WARNING!**

WARNING indicates a potentially hazardous situation which, if not avoided, could result in death or serious injury.

 **CAUTION!**

CAUTION indicates a potentially hazardous situation which, if not avoided, may result in minor or moderate injury.

 **IMPORTANT**

IMPORTANT indicates installation, operation or maintenance information which is important but not hazard-related.

1.4 Child safety

This appliance is not intended for use by persons (including children) with reduced physical, sensory or mental capabilities, or lack of experience and knowledge, unless they have been given supervision or instruction concerning use of the appliance by a person responsible for their safety.

Destroy or recycle the carton, plastic bags, and any exterior wrapping material immediately after the appliance is unpacked. Children should never use these items to play. Cartons covered with rugs, bedspreads, plastic sheets or stretch wrap may become airtight chambers, and can quickly cause suffocation.

1.5 Important safety instructions

 **DANGER**



DANGER Risk of fire or explosion. Flammable refrigerant used. Do not use mechanical devices to defrost the appliance. Do not puncture refrigerant tubing.

DANGER Risk of fire or explosion. Flammable refrigerant used. To be repaired only by trained service personnel. Use only manufacturer-authorized service parts. Any repair equipment used must be designed for flammable refrigerants. Follow all manufacturer repair instructions. Do not puncture refrigerant tubing.

 **CAUTION!**



CAUTION Risk of fire or explosion due to puncture of refrigerant tubing. Follow handling instructions carefully. Flammable refrigerant used.

This appliance is for storage only and should not be used for any other purpose.

Do not store or use gasoline or other flammable vapors and liquids in the vicinity of this or any other appliance.

Do not store explosive substances such as aerosol cans with a flammable propellant in this appliance.

Do not operate the appliance in the presence of explosive fumes. Avoid contact with any moving parts of automatic ice maker.

Remove all staples from the carton. Staples can cause severe cuts, and also destroy finishes if they come in contact with other appliances or furniture.

⚠ WARNING!

Do not use electrical appliances inside the food storage compartments of the appliance unless they are of the type recommended by the manufacturer.

⚠ WARNING!

CALIFORNIA RESIDENTS ONLY
WARNING! Cancer and Reproductive Harm <http://www.P65Warnings.ca.gov>

1.6 Proper disposal of your appliance

⚠ CAUTION!

CAUTION Risk of fire or explosion. Dispose of the appliance properly in accordance with the applicable federal or local regulations. Flammable refrigerant used.



Risk of child entrapment

Child entrapment and suffocation are not problems of the past. Junked or abandoned appliances are still dangerous – even if they will sit for “just a few days”. If you are getting rid of your old appliance, follow the instructions below to help prevent accidents.

We strongly encourage responsible appliance recycling/disposal methods. Check with your utility

company or visit <http://www.energystar.gov/recycle> for more information on recycling your old appliance.

Before you throw away your old appliance:

- Remove doors.
- Leave shelves in place so children may not easily climb inside.
- Have it removed by a qualified service technician.

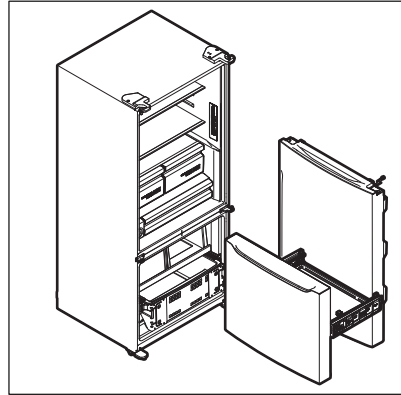

1.7 Electrical information

⚠ IMPORTANT

Pressing and holding the On/Off button for three seconds, located on the temperature control panel, will disable the appliance cooling system but does not disconnect the power to the light bulb and other electrical components. To turn off power to the appliance you must unplug the power cord from the electrical outlet.

- The appliance must be plugged into its own dedicated 115 Volt, 60 Hz., 15 Amp, AC only electrical outlet. The power cord of the appliance is equipped with a three-prong grounding plug for your protection against electrical shock hazards. It must be plugged directly into a properly grounded three-prong receptacle. The receptacle must be installed in accordance with local codes and ordinances. Consult a qualified

electrician. Do not use an extension cord or adapter plug.

WARNING!

Avoid fire hazard or electric shock.

- If the power cord is damaged, it should be replaced by an authorized service technician to prevent any risk.
- Never unplug the appliance by pulling on the power cord. Always grip the plug firmly, and pull straight out from the receptacle to prevent damaging the power cord.
- Unplug the appliance before cleaning and before replacing the light bulb to avoid electrical shock. Use only a 5-watt or less AC LED light bulb.
- Performance may be affected if the voltage varies by 10% or more. Operating the appliance with insufficient power can damage the compressor. Such damage is not covered under your warranty.
- Do not plug the unit into an electrical outlet controlled by a wall switch or pull

cord to prevent the appliance from being turned off accidentally.

- Do not pinch, knot, or bend the power cord in any manner.

WARNING!

When positioning the appliance, ensure the supply cord is not trapped or damaged.

Do not locate multiple portable socket-outlets or portable power supplies at the rear of the appliance.

WARNING!

Do not, under any circumstances, cut, remove, or bypass the grounding prong (A). Always use the power cord with a three-prong grounded plug and grounding type wall receptacle.



2. FEATURES

IMPORTANT

Features may vary by model.

Accessories are available for your appliance and may be purchased at Frigidaire.com or by calling toll-free 1-800-374-4432.

NOTE

Automatic ice makers are optional accessories that you may install in most models at any time. Visit Frigidaire.com for information about ice maker kit IM1900MD.

2.1 2-Door model

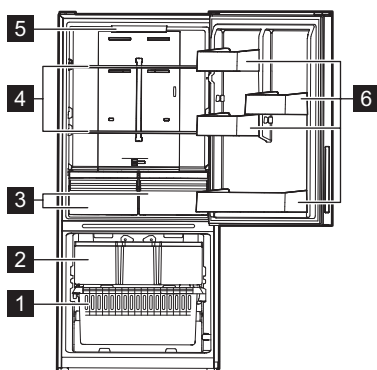

- 1 Lower Freezer Drawer
- 2 Top Freezer Drawer
- 3 Drawers
- 4 Glass Shelf
- 5 LED Lighting and Temperature Control Panel
- 6 Door Bins

2.2 3-Door model

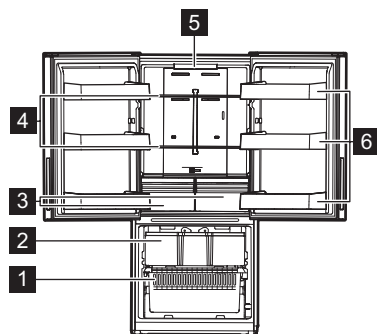

- 1 Lower Freezer Drawer
- 2 Top Freezer Drawer
- 3 Fruit and Vegetable Drawer
- 4 Glass Shelf
- 5 LED Lighting and Temperature Control Panel
- 6 Door Bins

3. INSTALLATION

This User Manual provides general installation and operating instructions for your model. We recommend using a service or kitchen contracting professional to install your appliance. Use the appliance only as instructed in this User Manual. Before starting the appliance, follow these important first steps.

3.1 ✓ Installation Checklist

Doors

- Handles are secure and tight
- Door seals completely the cabinet on all sides

Leveling

- Refrigerator is level side-to-side and slightly elevated in front to assist with door and drawer closing. Front should be higher than back.
- Cabinet is setting solid on all corners

Electrical Power

- House power is turned on
- Appliance is plugged in

Final Checks

- Shipping material is removed
- Refrigerator and freezer temperatures are set
- Crisper humidity controls are set
- Registration card is sent in

3.2 Location

- If possible, place the appliance out of direct sunlight and away from the range, dishwasher, or other heat sources.
- The appliance must be installed on a floor that is level and strong enough to support a fully loaded appliance.

⚠ WARNING!

This appliance is intended for use in residential household and similar interior applications such as:

- Kitchen / kitchenette
- Pantry room
- Basement
- Enclosed garage
- Other interior residential type environments

⚠ CAUTION!

Do not install the appliance where the temperature will drop below 38°F (3°C) or rise above 110 °F (43 °C). The compressor will not be able to maintain proper temperatures inside the appliance.

⚠ WARNING!

Allow the following clearances for ease of installation, proper air circulation, plumbing, and electrical connections:

- Top 3/8" (9.5 mm)
- Sides 3/8" (9.5 mm)
- Back 2" (50.8 mm)

🔧 NOTE

If you place the appliance with the door hinge side against a wall, you may have to allow additional space so the door can be open wider.

3.3 Leveling Feet

Level the appliance by raising or lowering the front adjustable feet.

1. To raise the appliance turn the feet clockwise.
2. To lower the appliance turn the feet counterclockwise
3. Adjust the right and left feet based on the procedures above to a horizontal level.

3.4 Door Alignment

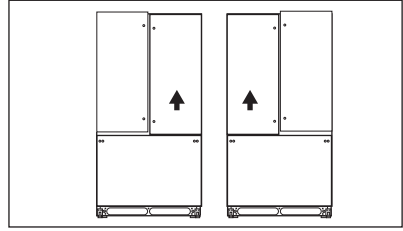

To align the door:

1. Take the washers from the plastic bag.
2. Lift the lower door up and insert the washer on the center hinge pin.
3. If necessary, repeat the steps on the other side of the appliance.

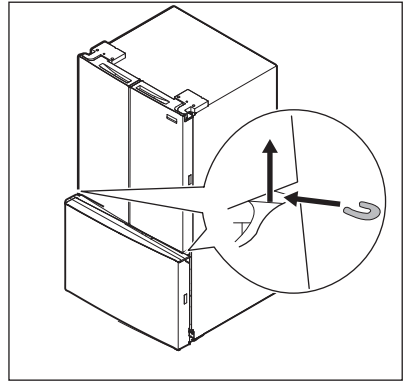

3.5 Flipper mullion

Adjust the flipper mullion for proper connection with the mullion guide. Ensure the flipper mullion is folded and perpendicular to the fresh food door. If the mullion guide is not in the correct position, it could prevent the door from closing completely.

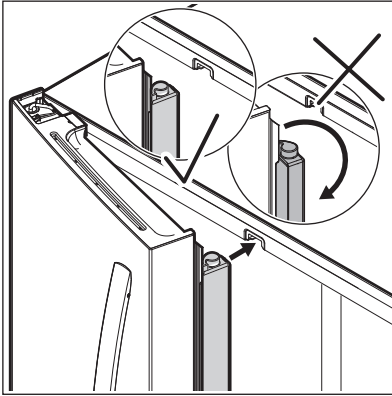

3.6 Door Handle Installation

IMPORTANT

Do not use a power tool to unscrew or tighten parts.

To install the door handle:

1. To install part A:
 - a. Locate the holes in the door where part A should be installed.
 - b. With a #3 Phillips head screwdriver install part A. Use firm pressure during installation.
 - c. Ensure part A ends up flush against the cabinet before proceeding to install the handle.
2. Remove the handles and any other protective packaging from the carton.
3. Position the handle end caps over upper and lower pre-installed shoulder bolts (A) that are fastened into door, ensuring the holes for the set screws are facing towards the opposite door.
4. While holding handle firmly against door, fasten upper and lower Allen set screws (B) with supplied Allen wrench.
5. Repeat the steps above to install the opposite handle. Ensure the holes for the set screws are facing towards the opposite door.

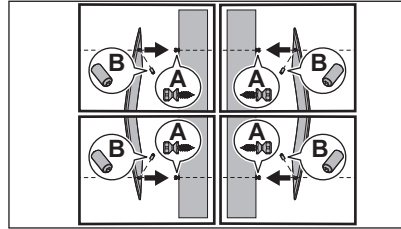

NOTE

When tightening the Allen set screws, apply force to the longer arm of the Allen wrench supplied in the handle packaging.

3.7 Door Reversal Instructions

WARNING!

Follow all steps when reversing the door swing. Failure to follow these instructions, leaving off parts or overtightening screws, can lead to the door falling off.

Required Tools:

- 5/16" socket and ratchet
- Phillips screwdriver
- Putty knife or thin-blade screwdriver
- Masking tape

NOTE

- When reversing the door swing:
- Read the instructions all the way through before starting.
 - Handle parts carefully to avoid scratching paint.
 - Set screws down by their related parts to avoid using them in the wrong places.
 - Provide a padded surface for the doors to avoid damage.
 - Do not move the appliance until door-swing reversal is completed.
 - Doors are heavy. Two people are recommended to remove or replace the door assembly from the cabinet.

NOTE

Instructions are for changing the hinges from the right side to the left side. To change hinges back to the right side, reverse all references to left and right.

1. Turn off the power by unplugging the appliance and remove all products from the door shelves.
2. Fix the door by tape.
3. Remove the left cover plate (A) and the right top hinge cover (B). Unscrew and remove the right top hinge (C). Keep the screws to reuse.

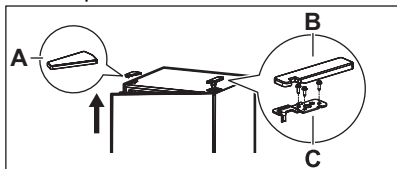

4. Remove the tape and lift the refrigerator door up and away from the appliance.
5. Dismantle the sleeves from the top right of doors and hole cap from top left of doors. Assemble them on the other side.
6. Remove the refrigerator door stopper (E), the middle hinge (F) and self-locking block (D) on the right. Take out the left self-locking block and stopper from the accessory bag and install on the left of doors.

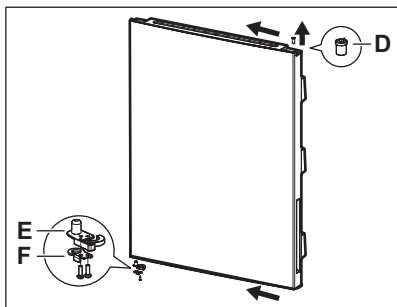

7. Remove the central hinge and hinge shaft with slotted screwdriver.
8. Install hinge shaft (G) on opposite side of the hinge and install the hinge (H) to the left of the appliance.

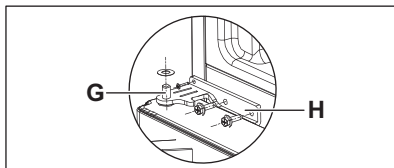

9. Put down the door on the middle hinge vertically.
10. Take out the top left hinge (J) and cover (I) from accessory bag, assemble top left hinge (J), left hinge cover (I) and cover plate (A).

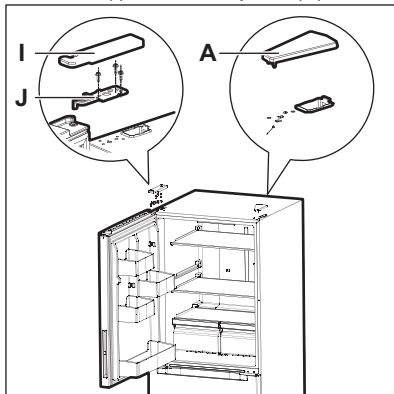

NOTE

The picture above is only a reference. The actual configuration depends on the physical product or statement by the distributor.

3.8 Tools necessary

These tools are necessary at different stages of the installation process:

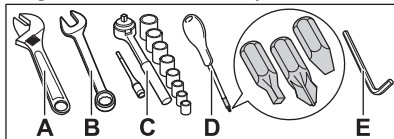

- A. Adjustable Wrench
- B. Fixed Wrench: 3/8"
- C. Socket Wrench: 8mm
- D. Screwdriver: Phillips™ Head or Flat Head or T20 Torx
- E. 6 mm Allen Wrench

3.9 Removing/Installing refrigerator doors

CAUTION!

The door is heavy. We recommend two people to remove or replace the door assembly from the cabinet.

NOTE

Do not use an electric tool to unscrew and screw parts.

To prepare for removing the doors:

1. Unplug the electrical power cord from the wall outlet.
2. Remove any food from the door shelves and close the doors.

WARNING!

Make sure the electrical power cord is unplugged from the wall outlet.

To remove refrigerator doors:

1. Trace lightly around the door top hinges with a pencil. This makes reinstallation easier. Remove the screw from the top hinge cover.

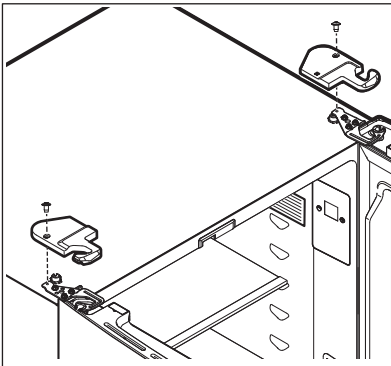

2. Disconnect electrical harness running from door to hinge cover.

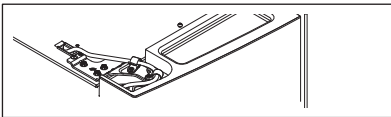

3. Remove three 8 mm bolts from both top hinges. Lift the doors up off lower hinges and carefully set aside.

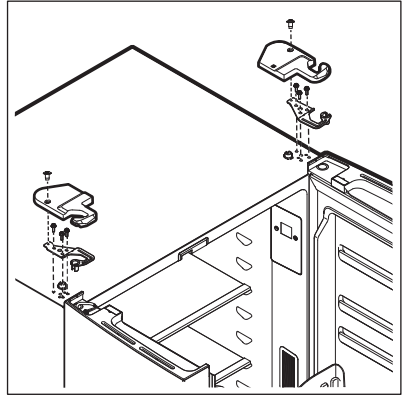

CAUTION!

Place the doors aside in a secure position where they cannot fall and cause personal injury or damage to the doors.

4. To gain access to the lower hinge, extend the drawer. Unscrew the lower hinge screws to remove the hinge.

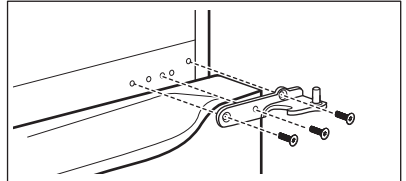

5. To reinstall doors, reverse the procedure.

Once both doors are in place, ensure they are aligned with each other and level and replace the top hinge cover. Refer to Installation.

4. CONTROLS AND SETTINGS

4.1 Appliance Control



- 1 Alarm/Power button
- 2 Power indicator
- 3 Fridge button
- 4 Fridge temperature indicator
- 5 Freezer button
- 6 Freezer temperature indicator

4.2 Clear Alerts

Alarm Off

When an alarm sounds, press the ALARM OFF button to deactivate it.

Door Open

If you leave freezer or refrigerator doors open for 120 seconds or more, the buzzer alarm appears. Close the door and press any key to reset the alarm.

Standby Mode

Press the ALARM OFF button for 3 seconds to enter or exit the standby mode. In this mode all functions and the display are off.

4.3 Temperature Regulation

Refrigerator Settings

Press the Fridge button to adjust the temperature. On the display, a snowflake symbol lights up when you adjust the temperature:

8°C 46°F ❄️
4°C 39°F ❄️❄️
2°C 35°F ❄️❄️❄️

Freezer Settings

Press the Freezer button to adjust the temperature. On the display, a snowflake symbol lights up when you adjust the temperature:

-16°C 3°F ❄️
-19°C -2°F ❄️❄️
-24°C -11°F ❄️❄️❄️

4.4 Sabbath Mode

Sabbath Mode is a function that disables parts of the appliance and its controls to meet the requirements of the Sabbath and religious holidays in the Orthodox Jewish community.

When Sabbath Mode is active, the light, sounds and appliance control are disabled. After a power failure, the appliance remains in Sabbath Mode. To activate/deactivate the function:

Press and hold Fridge and Freezer buttons simultaneously for 5 seconds. Indicators 1 and 6 light up.

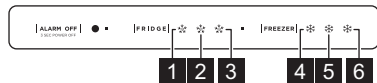

5. STORAGE FEATURES

5.1 Air Ports

Do not place items in front of the Air Ports as this impacts temperature performance.

IMPORTANT

If food is freezing in the fresh food compartment, increase the temperature setting 1 or 2 degrees.

IMPORTANT

Food placed within 1" in front of the air ports may cause food to freeze.

NOTE

The appliance should stabilize temperatures within 24 hours of installation.

5.2 Removing/Installing crisper drawers

Use the crisper to keep produce fresh for longer.

You can remove the drawer for cleaning. To remove the drawer:

1. Pull the drawer out until it stops.
2. Lift the front slightly and remove the drawer.
3. To remove rollers press them up.

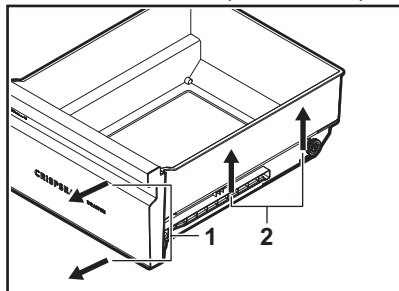

To install the drawer, reverse the procedure.

5.3 Adjustable door bins

Adjustable door bins are designed to hold containers, bottles or storage bags. Each bin can be removed or adjusted to suit individual needs.

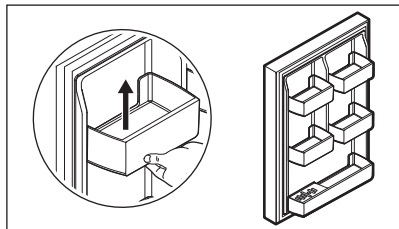

To move door bin side to side:

1. Tilt the bin up so the back is off the door but the hook is still engaged.

2. Slide the bin along the rail to the desired position.
 3. Lower the bin back into place.
- To move door bin up or down:

1. Lift the bin up to disengage the hook.
2. Move the bin to the desired rail location.
3. Push the bin hook into the rail to engage the hook.

5.4 Crisper Humidity Control (some models)

The crisper humidity control, present on the crisper drawers of some models, allows you to adjust the humidity within the crisper. This can extend the life of fresh vegetables that keep best in high humidity.

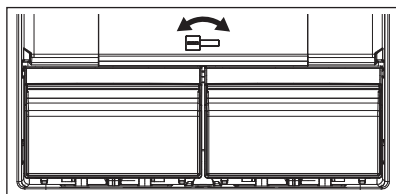

IMPORTANT

Store vegetables and/or fruit in the crisper drawers.

NOTE

Leafy vegetables keep best when stored with the humidity control set on high humidity, or in a drawer without a humidity control. This keeps incoming air to a minimum and maintains maximum moisture content. Store non-leafy vegetables and fruits still in their skins at the low humidity setting.

6. STORING FOOD AND SAVING ENERGY

6.1 Ideas for storing food

Fresh food storage

- Keep the fresh food compartment between 34°F and 40°F, with an optimum temperature of 37°F.

- Avoid overcrowding the refrigerator shelves, which reduces air circulation and causes uneven cooling.
- Avoid placing food in front of air ports.

Fruits and vegetables

- Store fruits and vegetables in crisper drawers, where trapped moisture helps

preserve food quality for longer time periods.

- Wash items and remove excess water.
- Wrap any items that have strong odors or high moisture content.

Meat

- Wrap raw meat and poultry separately and securely to prevent leaks and contamination of other foods or surfaces.

Frozen foods storage

- Keep the freezer compartment at 0°F or lower.
- A freezer operates most efficiently when it is at least 2/3 full.

Packaging foods for freezing

- To minimize food dehydration and quality deterioration, use aluminum foil, freezer wrap, freezer bags, or airtight containers. Force as much air out of the packages as possible and seal them tightly. Trapped air can cause food to dry out, change color, and develop an off-flavor (freezer burn).
- Wrap fresh meats and poultry with suitable freezer wrap prior to freezing.
- Do not refreeze meat that has completely thawed.

Loading the freezer

- Avoid adding too much warm food to the freezer at one time. This overloads the freezer, slows the rate of freezing, and can raise the temperature of frozen foods.
- Leave a space between packages, so cold air can circulate freely, allowing food to freeze as quickly as possible.

6.2 Ideas for energy saving

Installation

- Locate the refrigerator in the coolest part of the room, out of direct sunlight, and away from heating ducts or registers.
- Do not place the refrigerator next to heat-producing appliances such as a range, oven, or dishwasher. If this is not possible, a section of cabinetry or an added layer of insulation between the two appliances will help the refrigerator operate more efficiently.
- Level the refrigerator so that the doors close tightly.

Temperature setting

- Refer to Controls and Settings for procedures on temperature settings.

Food storage

- Avoid overcrowding the refrigerator or blocking cold air vents. Doing so causes the refrigerator to run longer and use more energy.
- Cover foods and wipe containers dry before placing them in the refrigerator. This cuts down on moisture build-up inside the unit.
- Organize the refrigerator to reduce door openings. Remove as many items as needed at one time and close the door as soon as possible.
- Do not place a hot container directly on a cold shelf. Remember, such an extreme temperature change may damage the glass.

7. NORMAL OPERATING SOUNDS

7.1 Understanding the sounds you may hear

Your new, high-efficiency appliance may introduce unfamiliar sounds. These sounds normally indicate your appliance is operating correctly. Some surfaces on floors, walls, and kitchen cabinets may make these sounds more noticeable.

NOTE

Energy efficient foam in your appliance is not a sound insulator.

Following is a list of major components in your appliance and the sounds they can cause:

- A.** Evaporator. Refrigerant through the evaporator may create a boiling or gurgling sound.
- B.** Evaporator fan. You may hear air being forced through the refrigerator by the evaporator fan.
- C.** Defrost heater. During defrost cycles, water dripping onto the defrost heater may cause a hissing or sizzling sound. After defrosting, a popping sound may occur.

- D. Electronic control & automatic defrost control. These parts can produce snapping or clicking sound when turning the cooling system on and off.
- E. Compressor. Modern, high-efficiency compressors run much faster than previous models. The compressor may have a noticeable hum or pulsating sound during operation.
- F. Drain pan (not removable). You may hear water dripping into the drain pan during the defrost cycle.
- G. Motorized damper. May produce intermittent humming during operation.

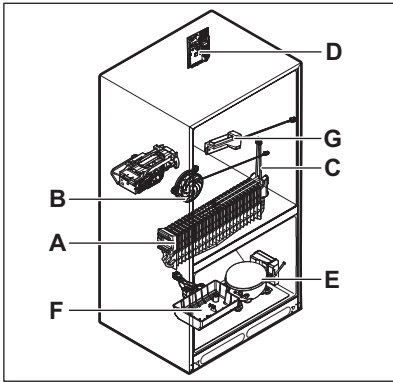

NOTE

During automatic defrost cycle, a red glow in the back wall vents of your freezer compartment is normal.

8. CARE AND CLEANING

8.1 Vacation and moving tips

Short vacations

- Leave the appliance operating during vacations of three weeks or less.
- Use all perishable items from the appliance compartment.

Long vacation

- Remove all food and ice if you will be gone one month or more.
- Unplug the appliance.
- Clean interior thoroughly.
- Leave both doors open to prevent odors and mold build-up. Block doors open if necessary.

Moving

- Unplug the appliance
- Remove all food and ice.
- Recommend use of a handcart, load from the side.
- Adjust rollers all the way up to protect them during sliding or moving.
- Pad cabinet to avoid scratching surface.

8.2 Care & Cleaning Tips

Part	What to use	Tips and precautions
Interior and door liners	<ul style="list-style-type: none"> • Soap and water • Baking soda and water 	Use 2 tablespoons of baking soda in 1 quart of warm water. Be sure to wring excess water out of sponge or cloth before cleaning around controls, light bulb or any electrical part.
Door gaskets	Soap and water	Wipe gaskets with a clean soft cloth.
Drawers and bins	Soap and water	Use a soft cloth to clean drawer runners and tracks.
Exterior and handles	<ul style="list-style-type: none"> • Soap and water • Non abrasive glass cleaner 	Do not use commercial household cleaners containing ammonia, bleach or alcohol to clean handles. Use a soft cloth to clean smooth handles. Do not use a dry cloth to clean smooth doors.
Exterior and handles (Stainless steel models only)	<ul style="list-style-type: none"> • Soap and water • Stainless steel cleaners 	Never use chloride or cleaners with bleach to clean stainless steel. Clean stainless steel front and handles with non-abrasive soapy water and a dishcloth. Rinse with clean water and a soft cloth. Use a non-abrasive stainless steel cleaner. These cleaners can be purchased at most home improvement or major department stores. Always follow manufacturer's instructions. Do not use household cleaners containing ammonia or bleach. Always clean, wipe and dry with the grain to prevent scratching. Wash the rest of the cabinet with warm water and mild liquid detergent. Rinse well, and wipe dry with a clean soft cloth.

9. TROUBLESHOOTING

Let us help you troubleshoot your concern! This section will help you with common issues. If you need us, visit our website, chat with an agent, or call us. We may be able to help you avoid a service visit. If you do need service, we can get that started for you! Visit Frigidaire.com or call toll-free 1-800-374-4432.

Opening/Closing of Doors/Drawers

Concern	Potential cause	Common solution
Door(s) does not close.	Door was closed too hard, causing other door to open slightly.	Close both doors gently.
	Refrigerator is not level. It rocks on the floor when moved slightly.	Ensure floor is level and solid, and can adequately support the refrigerator. Contact a carpenter to correct a sagging or sloping floor.
	Refrigerator is touching a wall or cabinet.	Ensure floor is level and solid, and can adequately support the refrigerator. Contact a carpenter to correct a sagging or sloping floor.
	Food/packaging is obstructing the door from closing.	Make sure there is no food/packaging blocking the doorway.

Concern	Potential cause	Common solution
Drawers are difficult to move.	Food is touching shelf on top of drawer.	Remove top layer of items in drawer.
	Track that drawers slide on is dirty.	<ul style="list-style-type: none"> • Ensure drawer is properly installed on track. • Clean drawer, rollers, and track. Refer to Care and Cleaning.

Running of appliance

Concern	Potential cause	Common solution
Compressor does not run.	The appliance is unplugged.	Ensure plug is tightly pushed into outlet.
	Refrigerator is in defrost cycle.	This is normal for a fully automatic defrost refrigerator. The defrost cycle occurs periodically, lasting about 30 minutes.
	House fuse blown or tripped circuit breaker.	Check/replace fuse with a 15 amp time-delay fuse. Reset circuit breaker.
	Power outage.	Check house lights. Call local electric company.

Refrigerator seems to run too much or too long.	The variable speed compressor is designed to run 100% of the time except during the defrost cycle. At times it will run faster, such as after a defrost cycle.	It is normal for the compressor to run continuously except during defrost mode.
Appliance seems to run continuously.	The appliances are designed with a variable speed compressor to be more energy efficient than previous models. This means your compressor reacts quickly to temperature fluctuations and circulates cold air based off your use and room temperature.	This is normal for a variable speed compressor refrigerator; however, if you have concerns, call toll-free 1-800-374-4432 or visit Frigidaire.com .

Digital temperature display

Concern	Potential cause	Common solution
Digital temperature displays an error.	Electronic control system has detected a performance problem.	Call your Frigidaire service representative, who can interpret any messages or number codes flashing on the digital displays.

Water/Moisture/Frost Inside Refrigerator

Concern	Potential cause	Common solution
Moisture collects on inside of refrigerator walls.	Weather is hot and humid.	The rate of frost buildup and internal sweating increases.
	Flipper mullion	Adjust flipper mullion. Refer to Flipper Mullion in Installation.
	Door is slightly open.	See the Opening/Closing of Doors/Drawers section above.
Water collects on bottom side of drawer cover.	Vegetables contain and give off moisture.	<ul style="list-style-type: none"> It is not unusual to have moisture on the bottom side of the cover. Move humidity control (some models) to lower setting.
Water collects in bottom of drawer.	Washed vegetables and fruit drain while in the drawer.	Water collecting in bottom of drawer is normal. Dry items before putting them in the drawer or store produce in tightly sealed bags to help reduce condensation inside of the drawer.

Water/Moisture/Frost Outside Refrigerator

Concern	Potential cause	Common solution
Moisture collects on outside of refrigerator or between doors.	Weather is humid.	This is normal in humid weather. When humidity is lower, the moisture should disappear.
	Door is slightly open, causing cold air from inside refrigerator to meet warm air from outside.	See the Opening/Closing of Doors/Drawers section above.

Food in Fresh food compartment

Concern	Potential cause	Common solution
Food is freezing.	Temperature setting is too low.	Move the setting to a higher degree.
	Temperature sensor is covered by food (right side of fresh food area).	Allow space for air flow to the sensor.
	Food is covering the air ports.	Allow space between the air ports and the food.

9.1 Errors

The following error codes might appear on the display indicating the malfunction of the appliance. The refrigerator may operate despite the following errors.



Error Code	Description
E1	Refrigerator temperature sensor error. Indicator 4 or 5 flashes.
E2	Freezer temperature sensor error. Indicator 1 or 5 flashes.
E5	Freezing frost sensor error. Indicator 3 or 5 flashes.

Error Code	Description
E6	Communication failure. Indicator 2 or 4 flashes.
E7	Ring temperature error. Indicator 2 or 5 flashes.

Error Code	Description
EH	Humidity sensor error. Indicator 1 or 4 flashes.

10. LIMITED WARRANTY

Your appliance is covered by a one year limited warranty. For one year from your date of delivery, Electrolux will pay all costs for repairing or replacing any parts of this appliance that prove to be defective in materials or workmanship when such appliance is installed, used and maintained in accordance with the provided instructions.

Exclusions

This warranty does not cover the following:

1. Products with original serial numbers that have been removed, altered or cannot be readily determined.
2. Product that has been transferred from its original owner to another party or removed outside the USA, Puerto Rico, or Canada.
3. Rust on the interior or exterior of the unit.
4. Products purchased "as-is" are not covered by this warranty.
5. Food loss due to any refrigerator or freezer failures.
6. Products used in a commercial setting.
7. Service calls which do not involve malfunction or defects in materials or workmanship, or for appliances not in ordinary household use or used other than in accordance with the provided instructions.
8. Service calls to correct the installation of your appliance or to instruct you how to use your appliance.
9. Expenses for making the appliance accessible for servicing, such as removal of trim, cupboards, shelves, etc., which are not a part of the appliance when it is shipped from the factory.
10. Service calls to repair or replace appliance light bulbs, air filters, water filters, other consumables, or knobs, handles, or other cosmetic parts.

11. Surcharges including, but not limited to, any after hour, weekend, or holiday service calls, tolls, ferry trip charges, or mileage expense for service calls to remote areas, including the state of Alaska.
12. Damages to the finish of appliance or home incurred during transportation or installation, including but not limited to floors, cabinets, walls, etc.
13. Damages caused by: services performed by unauthorized service companies; use of parts other than genuine Electrolux parts or parts obtained from persons other than authorized service companies; or external causes such as abuse, misuse, inadequate power supply, accidents, fires, or acts of God.

DISCLAIMER OF IMPLIED WARRANTIES; LIMITATION OF REMEDIES

CUSTOMER'S SOLE AND EXCLUSIVE REMEDY UNDER THIS LIMITED WARRANTY SHALL BE PRODUCT REPAIR OR REPLACEMENT AS PROVIDED HEREIN. CLAIMS BASED ON IMPLIED WARRANTIES, INCLUDING WARRANTIES OF MERCHANTABILITY OR FITNESS FOR A PARTICULAR PURPOSE, ARE LIMITED TO ONE YEAR OR THE SHORTEST PERIOD ALLOWED BY LAW, BUT NOT LESS THAN ONE YEAR. ELECTROLUX SHALL NOT BE LIABLE FOR CONSEQUENTIAL OR INCIDENTAL DAMAGES SUCH AS PROPERTY DAMAGE AND INCIDENTAL EXPENSES RESULTING FROM ANY BREACH OF THIS WRITTEN LIMITED WARRANTY OR ANY IMPLIED WARRANTY. SOME STATES AND PROVINCES DO NOT ALLOW THE EXCLUSION OR LIMITATION OF INCIDENTAL OR CONSEQUENTIAL DAMAGES, OR LIMITATIONS ON THE DURATION OF IMPLIED WARRANTIES,

SO THESE LIMITATIONS OR EXCLUSIONS MAY NOT APPLY TO YOU. THIS WRITTEN WARRANTY GIVES YOU SPECIFIC LEGAL RIGHTS. YOU MAY ALSO HAVE OTHER RIGHTS THAT VARY FROM STATE TO STATE.

If You Need Service

Keep your receipt, delivery slip, or some other appropriate payment record to establish the warranty period should service be required. If service is performed, it is in your best interest to obtain and keep all receipts. Service under this warranty must be obtained by contacting Electrolux at the addresses or phone numbers below.

This warranty only applies in the USA, Puerto Rico and Canada. In the USA and Puerto Rico, your appliance is warranted by Electrolux Consumer Products, Inc. In Canada, your appliance is warranted by Electrolux Canada Corp. Electrolux

authorizes no person to change or add to any obligations under this warranty. Obligations for service and parts under this warranty must be performed by Electrolux or an authorized service company. Product features or specifications as described or illustrated are subject to change without notice.

USA

1-800-374-4432

Electrolux Consumer Products, Inc.
10200 David Taylor Drive
Charlotte, NC 28262

Canada

1-800-265-8352

Electrolux Canada Corp.
5855 Terry Fox Way
Mississauga, Ontario, Canada L5V 3E4







11. QUEBEC RIGHT TO REPAIR

Though Frigidaire makes every effort to make replacement parts, repair services and information necessary to maintain or repair our products available to consumers, parts, service and information are not guaranteed, pursuant to section 39 of the Consumer Protection Act, CQLR, c. P-40.1 and sections 79.18 to 79.20 of the Regulation respecting the application of the Consumer Protection Act, CQLR, c. P-40.1, r. 3. If you need replacement parts, you may call us at 1 (800) 265-8352 for service in French or English, or purchase online at **Frigidaire Parts | Shop Frigidaire Replacement Parts & Accessories - Frigidaire Appliance Parts.**

You may book repair services online at <https://www.frigidaire.ca/RIGHT-TO-REPAIR/>. Alternatively, our resource library is available at **Resource Library | Frigidaire** to help you diagnose and resolve issues which may arise during the lifetime of your appliance.

Though most parts are available for purchase, subject to short-term availability constraints, the following appliances and parts are not serviceable.

Legend

Availability of replacement parts, repair services, and information for maintenance or repair.		
	Partially Available	
	Not Available	
	Available	
Refrigerators		Cabinet, 14cu ft and less no sealed system parts
Freezer		9 cu. ft and less no sealed system parts.
Beverage Centers		Only cosmetic parts available

