



# Refrigerator

## use & care

Introduction.....	2	Controls and Settings.....	16
Important Safety information.....	3	Automatic Water Dispenser.....	20
Features .....	6	Storage Features.....	21
Installation .....	8	Saving Energy .....	25
Door Reversal .....	11	Filter Replacement .....	26
Door Removal.....	12	Care and Cleaning .....	30
Door Handle Installation.....	13	Troubleshooting .....	32
Water Supply Connection (some models)...	14	Limited Warranty .....	35

# 2

## INTRODUCTION

Welcome to our **family**

Thank you for bringing Frigidaire into your home! We see your purchase as the beginning of a long relationship together.

This manual is your resource for the use and care of your product. Please read it before using your appliance. Keep it handy for quick reference. If something doesn't seem right, the troubleshooting section will help you with common issues.

FAQs, helpful tips and videos, cleaning products, and kitchen and home accessories are available at Frigidaire.com.

We are here for you! Visit our website, chat with an agent, or call us if you need help. We may be able to help you avoid a service visit. If you do need service, we can get that started for you.

Let's make it official! Be sure to register your product.

Keep your product info here so it's easy to find.

Model Number \_\_\_\_\_

Serial Number \_\_\_\_\_

Purchase Date \_\_\_\_\_

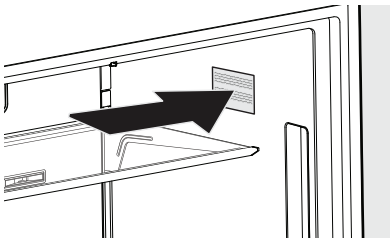

**Serial Number Location**



### **Installation Checklist**

#### **Doors**

- Handles are secure and tight
- Door seals completely to cabinet on all sides
- Door is level from side to side across the top

#### **Leveling**

- Appliance is level, side to side and front to back
- Cabinet is setting solid on all corners
- Anti-tip bracket is set in front (hinge side)

#### **Electrical Power**

- House power turned on
- Appliance is plugged in

#### **Water Supply**

- House water supply is connected to appliance (**Warning:** Potable water supply only.)
- No water leaks present at all connections - recheck in 24 hours

#### **Final Checks**

- Shipping material is removed
- Registration card is sent in
- Appliance temperatures are set to the recommended settings
- Provided accessories and consumables are installed



## WARNING

Please read all instructions before using this appliance.

### Safety Definitions

 This is the safety alert symbol. It is used to alert of potential personal injury hazards. Obey all safety messages that follow this symbol to avoid possible injury or death.



## DANGER

DANGER indicates an imminently hazardous situation which, if not avoided, will result in death or serious injury.



## WARNING

WARNING indicates a potentially hazardous situation which, if not avoided, could result in death or serious injury.



## CAUTION

CAUTION indicates a potentially hazardous situation which, if not avoided, may result in minor or moderate injury.



## IMPORTANT

IMPORTANT indicates installation, operation or maintenance information which is important but not hazard-related.



## WARNING

When positioning the appliance, ensure the supply cord is not trapped or damaged.



## WARNING

Do not locate multiple portable socket-outlets or portable power supplies at the rear of the appliance



## DANGER



DANGER Risk of fire or explosion. Flammable refrigerant used. Do not use mechanical devices to defrost refrigerator. Do not puncture refrigerant tubing.

DANGER Risk of fire or explosion. Flammable refrigerant used. To be repaired only by trained service personnel. Use only manufacturer-authorized service parts. Any repair equipment used must be designed for flammable refrigerants. Follow all manufacturer repair instructions. Do not puncture refrigerant tubing.



## CAUTION



CAUTION Risk of fire or explosion. Dispose of refrigerator properly in accordance with the applicable federal or local regulations. Flammable refrigerant used.

CAUTION Risk of fire or explosion due to puncture of refrigerant tubing. Follow handling instructions carefully. Flammable refrigerant used.



## WARNING

**CALIFORNIA RESIDENTS ONLY**  
**Cancer and Reproductive Harm**  
**[www.P65Warnings.ca.gov](http://www.P65Warnings.ca.gov)**

# 4

## IMPORTANT SAFETY INFORMATION

---

### Child Safety

This appliance is not intended for use by persons (including children) with reduced physical, sensory or mental capabilities, or lack of experience and knowledge, unless they have been given supervision or instruction concerning use of the appliance by a person responsible for their safety.

Destroy or recycle the carton, plastic bags, and any exterior wrapping material immediately after you unpack the refrigerator. Children should **NEVER** use these items to play. Cartons covered with rugs, bedspreads, plastic sheets or stretch wrap may become airtight chambers, and can quickly cause suffocation.

### Safety Instructions

- DO NOT store or use gasoline, or other flammable liquid within or in the vicinity of this appliance. Read Product Label for warnings regarding flammability and other hazards.
- DO NOT store explosive substances such as aerosol cans with a flammable propellant in this appliance.
- DO NOT operate the refrigerator in the presence of explosive fumes.
- Avoid contact with any moving parts of automatic ice maker.
- Remove all staples from the carton. Staples can cause severe cuts, and also destroy finishes if they come in contact with other appliances or furniture.



### WARNING

Do not use electrical appliances inside the food storage compartments of the appliance unless they are of the type recommended by the manufacturer.

### Proper Disposal of your Appliance

#### Risk of child entrapment

Child entrapment and suffocation are not problems of the past. Junked or abandoned appliances are still dangerous – even if they will sit for “just a few days”. If you are getting rid of your old appliance, please follow the instructions below to help prevent accidents.

We strongly encourage responsible appliance recycling/disposal methods. Check with your utility company or visit [energystar.gov/products/recycle](http://energystar.gov/products/recycle) for more information on recycling your old appliance.

#### Before you throw away your old appliance:

- Remove door.
- Leave shelves in place so children may not easily climb inside.
- Have refrigerant removed by a qualified service technician.

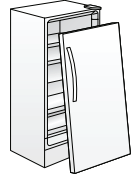



## WARNING

Follow these guidelines to ensure safety mechanisms in this appliance will operate properly.



## IMPORTANT

To turn off power to your appliance you must unplug the power cord from the electrical outlet.

## Electrical information

- Plug the appliance into its own dedicated 115 Volt, 60 Hz., 15 Amp, AC only duplex electrical outlet. The power cord of the appliance is equipped with a 3-prong grounding plug for your protection against electrical shock hazards. Plug it directly into a properly grounded 3-prong receptacle. Install the receptacle in accordance with local codes and ordinances. Consult a qualified electrician. Do not use an extension cord or adapter plug.
- If the power cord is damaged, an authorized service technician should replace it to prevent any risk.
- Never unplug the appliance by pulling on the power cord. Always grip the plug firmly, and pull straight out from the receptacle to prevent damaging the power cord.
- Unplug the appliance before cleaning to avoid electric shock.
- Performance may be affected if the voltage varies by 10% or more. Operating the appliance with insufficient power can damage the compressor. Such damage is not covered under your warranty.
- Do not plug the unit into an electrical outlet controlled by a wall switch or pull cord to prevent the appliance from being turned off accidentally.

## Appliance Setup

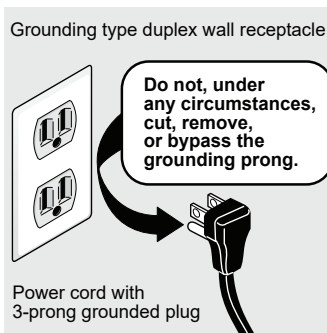

Use a dedicated grounding-type duplex electrical outlet for each unit (i.e. two duplex outlet receptacles, each on a dedicated electrical circuit) for a paired unit configuration



## WARNING

When positioning the appliance, ensure the supply cord is not trapped or damaged.



## WARNING

Do not locate multiple portable socket-outlets or portable power supplies at the rear of the appliance

# 6

## FEATURES

Features may vary according to model

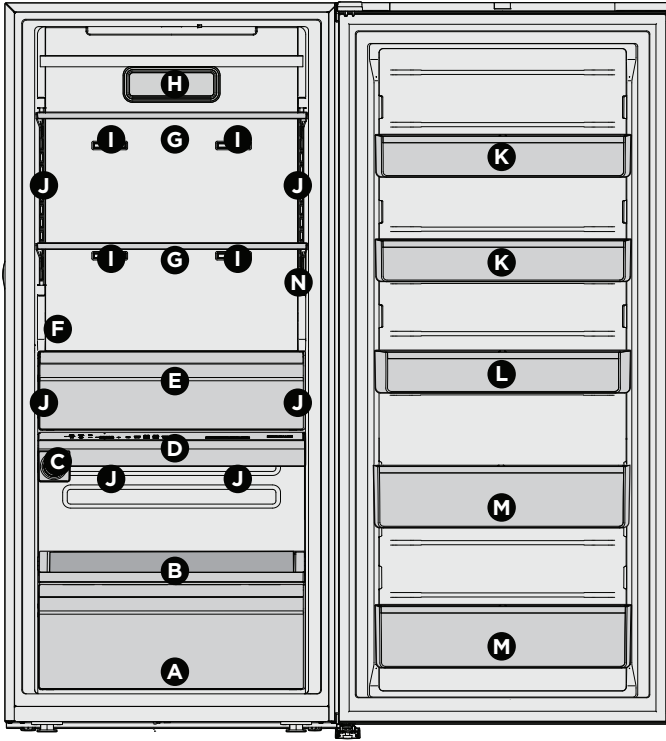

<b>A</b>	Lower Drawer with Removable Dividers
<b>B</b>	Slide-out Shelf
<b>C</b>	Water Filter
<b>D</b>	Appliance Control Display
<b>E</b>	CrispSeal Plus Drawer with Auto Humidity and Produce Keeper™
<b>F</b>	Internal Water Dispenser
<b>G</b>	Adjustable Full Width Glass Shelves

<b>H</b>	Air Filter
<b>I</b>	*Multi-Port Air Exhaust Ducts
<b>J</b>	LED Lighting
<b>K</b>	Adjustable Half Gallon Door Bins with Removable Dividers
<b>L</b>	Adjustable Gallon Door Bin with Removable Divider
<b>M</b>	Adjustable Tall Item Door Bins with Removable Dividers
<b>N</b>	Temperature Sensor/Thermistor

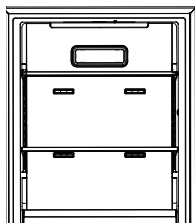

### IMPORTANT

\*Do not place items in front of the Multi-Port Air Exhaust Ducts or the Temperature Sensor as this will impact temperature performance.

**IMPORTANT****Cleaning your Appliance**

Remove tape and glue residue from surfaces before turning on the appliance. Rub a small amount of liquid dish soap over any remaining adhesive with your fingers. Rinse with warm water and dry with a soft cloth.

Do not use sharp instruments, rubbing alcohol, flammable fluids, or abrasive cleaners to remove tape or glue. These products can damage the surface of your appliance.

After you remove all of the package materials, clean the inside of your appliance before using it. See the **CARE AND CLEANING** section in this manual.

See important information about cleaning glass shelves and covers in the **STORAGE FEATURES** section of this manual.

**IMPORTANT****Moving your Appliance**

Your appliance is heavy. When moving the appliance for cleaning or service, raise the anti-tip bracket (see **Setting the anti-tip bracket**). Be sure to cover the floor with cardboard or hardboard to avoid floor damage. Always pull the appliance straight out when moving it. Do not wiggle or “walk” the appliance when trying to move it as floor damage could occur.

**IMPORTANT**

Accessories are available for your appliance and may be purchased at [Frigidaire.com](http://Frigidaire.com) or by calling 1-800-374-4432 (Frigidaire.ca or 1-800-265-8352 in Canada) or from an authorized seller.

# 8

## INSTALLATION

This Use & Care Manual provides general operating instructions for your model. Use the appliance only as instructed in this Use & Care Manual. **Before starting the appliance, follow these important first steps.**

### Location

- Choose a place near a grounded electrical outlet. Do Not use an extension cord or an adapter plug.
- If possible, place the appliance out of direct sunlight and away from the range, dishwasher or other heat sources.
- Install the appliance on a floor level and strong enough to support a fully loaded appliance.



### WARNING

This appliance is intended for use in residential household and similar interior applications such as:

- Kitchen / Kitchenette
- Pantry Room
- Basement
- Enclosed Garage
- Other interior residential type environments



### WARNING

DO NOT install the appliance where the temperature will drop below 55°F (13°C) or rise above 110°F (43°C). The compressor will not be able to maintain proper temperatures inside the unit.



### CAUTION

Do not block the lower front of your appliance. Sufficient air circulation is essential to operate your appliance properly.

## Installation



### WARNING

#### Installation clearances

Allow the following clearances for ease of installation, proper air circulation, and plumbing and electrical connections:

Sides	3/16"
Top & Back	1"

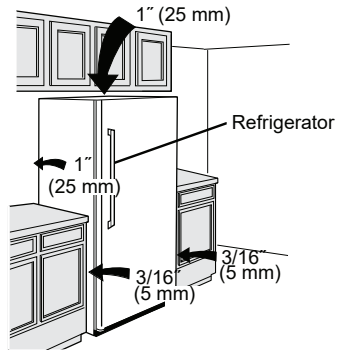

### NOTE

If you place your appliance with the door hinge side against a wall, you may have to allow additional space for the handle so you can open the door wider.

### Minimum Cabinet dimensions for Single Unit WITHOUT Trim Kit

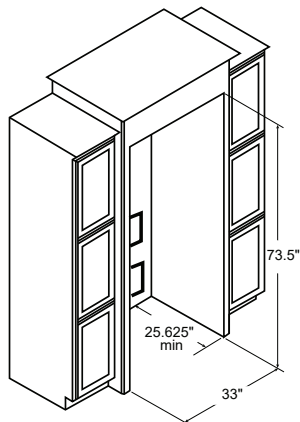

## Recommended Tools

- Level
- Appliance Slider



### CAUTION

This unit does not have rollers. Use an appliance slider or protective floor covering while moving the unit into place. Do not slide the unit with leveling legs fully extended.

## Leveling

Rest all bottom feet firmly on a solid floor.

It is **VERY IMPORTANT** for your unit to be level in order to function properly. If you do not level the appliance during installation, the door may be misaligned and not close or seal properly, causing cooling, frost or moisture problems.



### CAUTION

The cabinet is heavy. We recommend two people to level the cabinet.

## To Level the Appliance:

Insert the appliance slider under the unit. Place the unit into its location. Use the carpenter's level to make sure the unit is level from front to back and side to side. First adjust the front leveling legs, and then the rear if necessary. If you cannot access the rear leveling legs, slide the unit back out and adjust it. Slide the unit back into place and recheck with the level. Repeat if necessary.

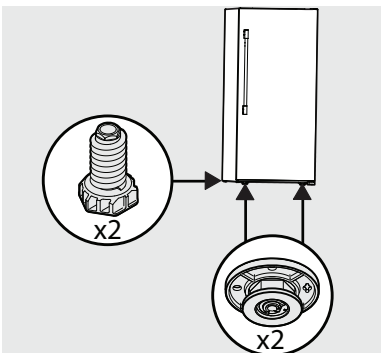

## Setting the anti-tip bracket:

Units are equipped with an anti-tip bracket. The anti-tip bracket is located on the lower front corner of the cabinet, on the lower hinge bracket. After fully leveling the unit, lower the anti-tip foot by turning it clockwise until it securely contacts the floor. Do not raise the cabinet.

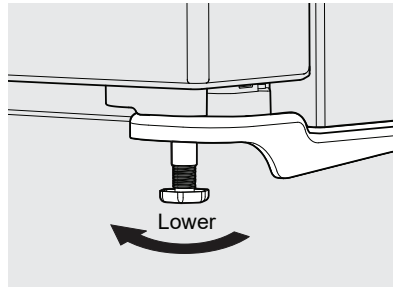

Anti-tip Bracket



### WARNING



Install the anti-tip device according to the instructions in your Use & Care Manual. Failure to do so may result in injury.

# 10 INSTALLATION

## Lower Hinge Adjustment for Leveling the Doors of the Matching Refrigerator / Freezer Pair

To level the doors using the adjustable lower hinge (some models):

If the refrigerator door is lower than the freezer door, raise the refrigerator door by turning the adjustment screw counter-clockwise using a 19 mm socket wrench. (See illustration below.)

If the freezer door is lower than the refrigerator door, raise the freezer door by turning the adjustment screw counter-clockwise using a 19 mm socket wrench. (See illustration below.)

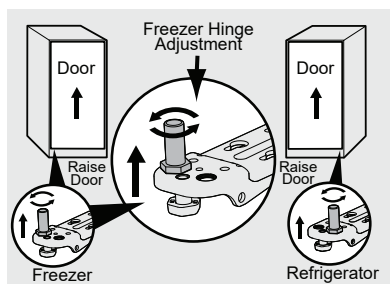

## Guidelines for final positioning of your appliance:

- Rest all bottom leveling feet firmly on a solid floor.
- Level the cabinet on all sides.
- Level the door.

## Pairing Installation

Pairing kit (TWINSPAIRKIT) is REQUIRED if you are installing the following appliances next to each other:

- Freezer and Refrigerator
- Freezer and Freezer
- Refrigerator and Refrigerator

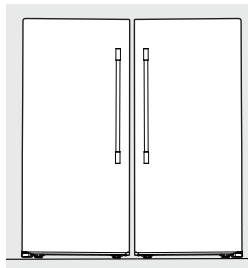

To obtain this kit, please contact the retailer where you purchased your appliances, or contact Frigidaire customer service at 1-800-374-4432 in the US, 1-800-265-8352 in Canada.

## Filtered Ice Kit

In order for the freezer ice maker to have filtered water for ice, we recommend filtered ice kit (TTICEKITSVC) when you are installing the following appliances next to each other:

- Freezer and Refrigerator

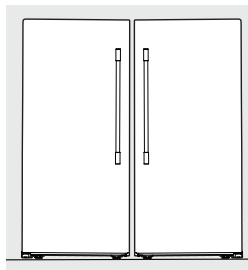

To obtain this kit, please contact the retailer where you purchased your appliances, or contact Frigidaire customer service at 1-800-374-4432 in the US, 1-800-265-8352 in Canada.

## Single Unit Door Swing Reversal:

- **TTDRRVFRKIT2 Frig Pro TT Refrigerator** - Right-hand to Left-hand Swing
- **TTDRRVFFKIT2 Frig Pro TT Freezer** - Left-hand to Right-hand Swing

## For Model with Gray interior walls:

- **TTDRRVGRKIT2 Frig Pro TT Grey Liner Refrigerator** - Right-hand to Left-hand Swing
- **TTDRRVGFKIT2 Frig Pro TT Grey Liner Freezer** - Left-hand to Right-hand Swing

Order the kit on Frigidaire.com or by calling 1-800-374-4432 (Frigidaire.ca or 1-800-265-8352 in Canada).

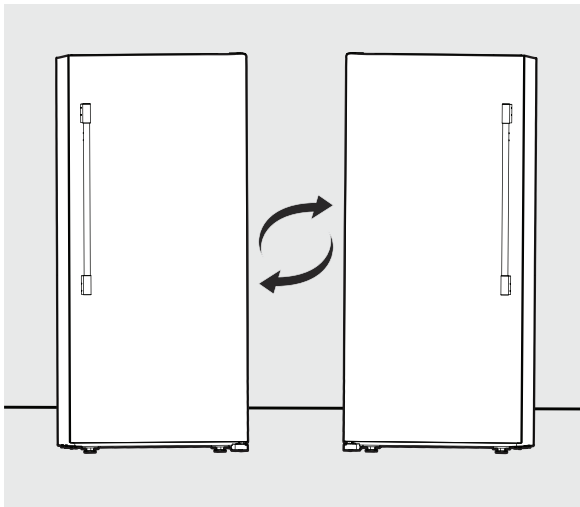

Right-hand Swing

Left-hand Swing

## Dual Unit Door Reversal:

- Moving the Refrigerator door to the Freezer also changes the left-hand swing to a right-hand swing.
- Moving the Freezer door to the Refrigerator also changes the right-hand swing to a left-hand swing.



### NOTE

You need to also transfer the hinges and associated hardware in order to the switch doors.



### CAUTION

Doors are heavy. Two people are recommended to remove or replace the door assembly from the cabinet.

# 12

## DOOR REMOVAL

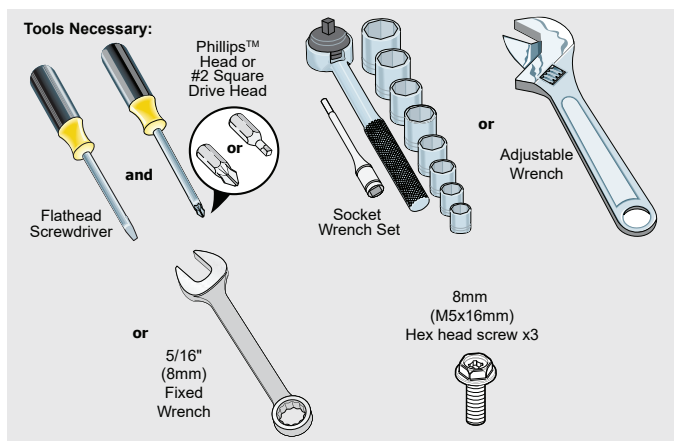

### Door removal:



#### IMPORTANT

Before you begin, remove the electrical power cord from the wall outlet. Remove any food from door bins.



#### CAUTION

Doors are heavy. Two people are recommended to remove or replace the door assembly from the cabinet.



#### CAUTION

Close the door prior to removing or installing.

- Unplug the unit or switch the breaker that supplies power to the unit to the off position.
- Hold the door in place while removing the top hinge from the cabinet.
- Remove the M5x16 mm hex head screws from the top hinge with a wrench or socket.
- Lift the door upward and pull up and away from the cabinet until free of the bottom hinge pin mounted on the front of the cabinet.
- To replace the door, reverse the above procedures and securely tighten all screws to prevent hinge slippage.

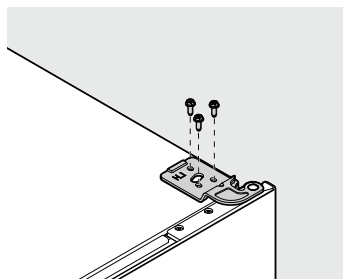

If you need to remove the door to transport your unit, you must have a consistent 9 mm door gap around the perimeter of the cabinet to ensure proper gasket sealing to prevent frost in freezer. Measure the 9 mm gap from the metal of the cabinet to the metal on the door.

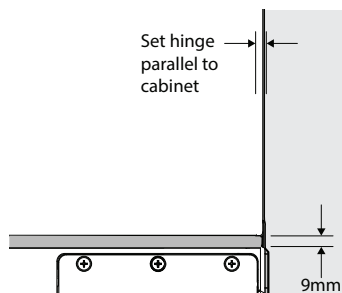

**CAUTION**

Wear gloves and use extreme CAUTION when installing these handles. The rounded end of the handles may be sharp.

**NOTE**

Tighten and sub flush all set screws (Allen set screw should be seated just below the surface of the end cap) of the handle end cap. Tightly draw the end caps to the door with no gaps.

**Door Handle Mounting Instructions**

1. Remove the handle and any protective packaging from inside the appliance.
2. Position the handle end caps over the upper and lower pre-installed shoulder bolts (A) fastened into the door, ensuring the holes for the set screws are facing away from the hinge.
3. While holding the handle firmly against the door, fasten the upper and lower Allen set screws (B) with the supplied Allen wrench.

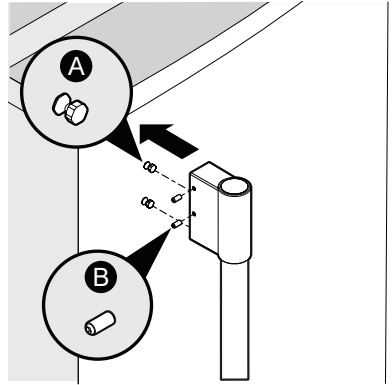

**WARNING**

To avoid electric shock, which can cause death or severe personal injury, disconnect the unit from electrical power source before connecting a water supply line to the appliance.

**CAUTION**

To Avoid Property Damage:

- Use Copper or Stainless Steel braided tubing for the water supply line. We do not recommend water supply tubing made of ¼" plastic. Plastic tubing greatly increases the potential for water leaks, and the manufacturer will not be responsible for any damage if plastic tubing is used for the supply line.
- DO NOT install water supply tubing in areas where temperatures fall below freezing.

**NOTE**

Ensure your water supply line connections comply with all local plumbing codes.

**Before Installing The Water Supply Line, You Will Need:**

- Basic Tools: adjustable wrench, flat-blade screwdriver, and Phillips™ screwdriver
- Access to a household cold water line with water pressure between 30 and 100 psi.
- A braided stainless steel water supply line with integral fittings such as **Smart Choice**® 5304437642 or ¼" copper line with compression fittings. The line must be 6' or longer to allow appliance to be moved out for cleaning.
- A shutoff valve to connect the water supply line to your household water system. DO NOT use a self-piercing type shutoff valve.
- Do not reuse compression fitting or use thread seal tape.

- A compression nut and ferrule (sleeve) for connecting a copper water supply line to the water valve.

**To Connect Water Supply Line To Water Inlet Valve**

1. Disconnect the refrigerator from the electrical power source.
2. Place the end of the water supply line into a sink or bucket. Turn ON the water supply and flush the supply line until the water is clear. Turn OFF the water supply at the shutoff valve.
3. Remove the plastic cap from the water valve inlet and discard the cap.
4. If you use **copper tubing** - Slide the brass compression nut and then the ferrule (sleeve) onto the water supply line. Push the water supply line into the water valve inlet as far as it will go (¼"/6.4 mm). Slide the ferrule (sleeve) into the valve inlet and finger tighten the compression nut onto the valve. Tighten another half turn with a wrench; DO NOT overtighten. See Figure 1.

If you use **braided flexible stainless steel tubing** - The nut is already assembled on the tubing. Slide the nut onto the valve inlet and finger tighten the nut onto valve. Tighten another half turn with a wrench; DO NOT overtighten. See Figure 2.

5. With the steel clamp and screw, secure the water supply line (copper tubing only) to the rear panel of refrigerator as shown.
6. Coil the excess water supply line (copper tubing only), about 2½ turns, behind refrigerator as shown and arrange coils so they do not vibrate or wear against any other surface.
7. Turn ON the water supply at shutoff valve and tighten any connections that leak.
8. Reconnect the appliance to the electrical power source.

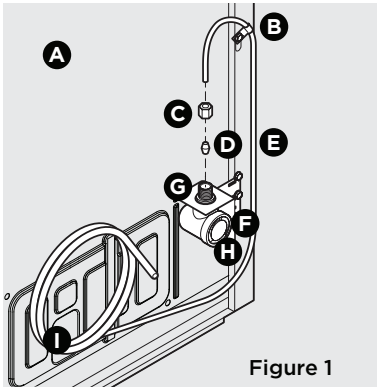

Figure 1

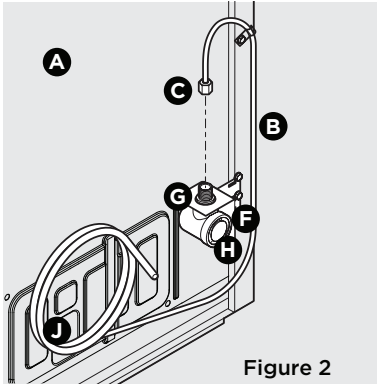

Figure 2

**NOTE**

Check with your local building authority for recommendations on water lines and associated materials prior to installing your new refrigerator. Depending on your local/state building codes, We recommend for homes with existing valves its **Smart Choice**<sup>®</sup> water line kit 5305513409 (with a 6' Stainless Steel Water Line) and for homes without an existing valve, we recommend **Smart Choice**<sup>®</sup> water line kit 5305510264 (with a 20' copper water line with self-tapping saddle valve). Please refer to Frigidaire.com for more information.

<b>A</b>	Plastic Water Tubing to Water Dispenser (foamed within the cabinet)
<b>B</b>	Steel Clamp (Fig. 1: 1/4"; Fig. 2: 1/2")
<b>C</b>	Brass Compression Nut
<b>D</b>	Ferrule (Sleeve)
<b>E</b>	Copper Water Line
<b>F</b>	Water Valve Bracket
<b>G</b>	Valve Inlet
<b>H</b>	Water Valve
<b>I</b>	Copper Water Line from Household Water Supply*
<b>J</b>	Braided Flexible Stainless Steel Water Line
*Include enough tubing in the loop to allow moving the refrigerator out for cleaning	

# 16

## CONTROLS AND SETTINGS

---

### Cool Down Period

To ensure safe food storage, allow the appliance to operate with the door closed for at least 8 hours before loading it with food.

### Power On

Upon opening the door, the settings icon illuminates on the appliance control display.



By pressing the settings icon, you illuminate all of the icons on the appliance control. After 10 seconds of no user interaction with the icons or door closure, all the icons fade, except for the settings icon.

### Appliance Control Display

The appliance control display is located in the cabinet below the upper drawer.

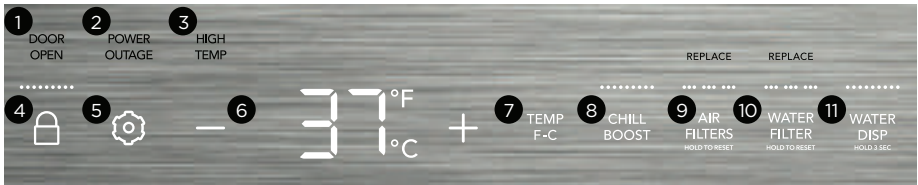
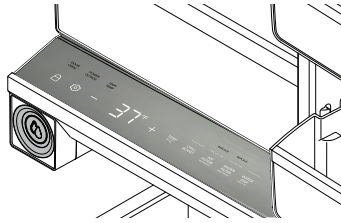



Features may vary by model.

## Alarms

- 1 DOOR OPEN**  
This alert indicates the door has been open for 5 minutes or more. The **DOOR OPEN** LED illuminates and the audible alert sounds until the door is closed.  
You can turn off the audible alert by pressing **DOOR OPEN** or by closing the door. If the door is ajar for 5 minutes, the interior light turns off.
- 2 POWER OUTAGE**  
The **POWER OUTAGE** indicator light informs you of a power interruption. Reset the alarm by pressing **POWER OUTAGE**.
- 3 HIGH TEMP**  
If the temperature increases above a safe temperature range, the red **HIGH TEMP** LED light illuminates and the alarm sounds. Reset the alarm by pressing **HIGH TEMP**.

## Controls

- 4** You can use the lock button to lock the control display. Press and hold  for 3 seconds to enable. While in the locked state, you cannot make changes until unlocked. Press and hold  for 3 seconds to disable.
- 5** The settings icon illuminates upon opening the appliance door. Press the settings icon to reveal other function icons. After 10 seconds of non use of icons or door closure, all icons fade except the settings icon.
- 6 Adjusting Temp**  
To adjust the temperature setting, press **+** to raise the temperature and **-** to lower the temperature on the appliance control display. Allow several hours for the temperature to stabilize between adjustments.
- 7 TEMP °F/°C**  
Short press to toggle between Fahrenheit (°F) and Celsius (°C).
- 8 CHILL BOOST**  
Turning on **CHILL BOOST** cools the appliance down to a target temperature and remains active for up to 24 hours before automatically deactivating or being manually exited. To turn the function on/off, press **CHILL BOOST**. When you turn off **CHILL BOOST**, it automatically resets the refrigerator back to the previous temperature setting.
- 9 AIR FILTERS**  
The **AIR FILTERS** replacement alert illuminates when it is time to replace the air filters. See the **FILTER REPLACEMENT** section for instructions on how to replace the air filters. After changing the air filters, reset the **AIR FILTERS** alert by pressing and holding **AIR FILTERS**.
- 10 WATER FILTER**  
The **WATER FILTER** replacement alert illuminates when it is time to replace the water filter. See the **FILTER REPLACEMENT** section for instructions on how to replace the water filter. After changing the water filter, reset the **WATER FILTER** alert by pressing and holding **WATER FILTER**. After replacing the water filter, see the **AUTOMATIC WATER DISPENSER** section for instructions on how to prime the water system.
- 11 WATER DISP**  
The illuminated **WATER DISP** LED means the internal water dispenser is ON. Open the internal water dispenser by pushing the push-push nozzle. Press the water dispenser paddle inside the cabinet to dispense water. Turn the dispenser off by pressing and holding **WATER DISP** for 3 seconds. When the water dispenser is off, you cannot dispense water. You will hear a beep if you try to press the paddle without turning on **WATER DISP**. Press and hold **WATER DISP** to turn it on.

# 18

## CONTROLS AND SETTINGS

---

### Sabbath Mode

The Sabbath Mode feature disables portions of the appliance and its controls in accordance with observance of the weekly Sabbath and religious holidays within the Orthodox Jewish community.

#### To enter Sabbath Mode

Simultaneously press and hold **—** and **TEMP F/C** for 5 seconds.

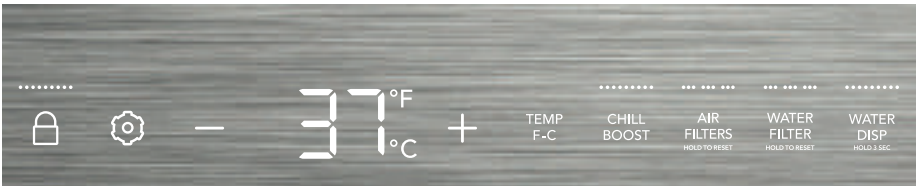

**Sb** appears on the appliance control display indicating the unit is in Sabbath mode.



★ For further assistance, guidelines of proper usage and a complete list of models with the Sabbath feature, please visit the web at [star-k.org](http://star-k.org).

The unit stays in Sabbath mode after a power failure recovery. You must deactivate it with the buttons on the appliance control display.



#### NOTE

While in the Sabbath Mode, neither the lights nor the appliance control display will work (except to exit Sabbath Mode) until you deactivate Sabbath Mode.

The appliance stays in Sabbath Mode after power failure recovery. You must deactivate it with the buttons on the appliance control display.

## To exit Sabbath Mode

Simultaneously press and hold — and **TEMP F/C** for 5 seconds.



The appliance control display shows all of the icons depending on your model.

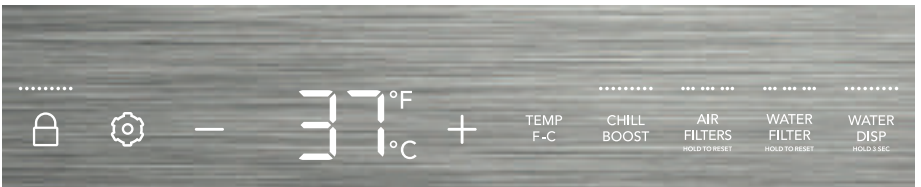

In the Sabbath mode, the **HIGH TEMP** alarm is active for health reasons. For example, if you leave the door ajar, the **HIGH TEMP** alarm is activated. The refrigerator functions normally once you close the door, without any violation of the Sabbath/holidays. The **HIGH TEMP** alarm comes on when the cabinet temperature is outside the safe zone for 20 minutes. The alarm silences itself after 10 minutes while the **HIGH TEMP** icon stays lit until you exit the Sabbath mode.

All buttons are disabled, and all sounds (except the **HIGH TEMP** alert\*) are muted. Only the **HIGH TEMP** alert illuminates until you deactivate the Sabbath Mode.



Your refrigerator might be equipped with an internal water dispenser mounted inside the cabinet, along the left-hand cabinet wall (varies by model).

Before using the water dispenser for the first time or after changing the water filter, you must prime your water supply system.

### Priming the water supply system



#### CAUTION

For proper dispenser operation, the recommended water supply pressure should fall between 30 psi and 100 psi. Excessive pressure may cause the system to malfunction.

### Using the dispenser after installation:

If you do not flush the system, the first glass of water may have discolored water or have an odd flavor.

1. Begin filling the system by pressing a drinking glass against the water dispenser paddle.
2. Keep the glass in this position until the water comes out of the dispenser. It may take about 1½ minutes.
3. Continue dispensing water for about 4 minutes to flush the system and plumbing connections of any impurities (stopping to empty the glass as necessary).

If the water dispenser function becomes disabled, enable the water dispenser by pressing and holding **WATER DISP** on the appliance control display. When you turn on the water dispenser, the LEDs above **WATER DISP** illuminate.



#### NOTE

If you prefer to keep the internal water dispenser disabled, use the appliance control display to disable it. The LEDs will not illuminate above **WATER DISP**.

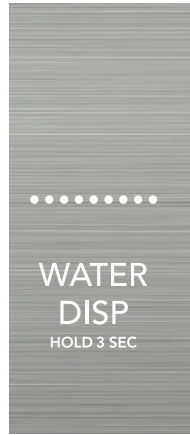

Water Dispenser  
On



Water Dispenser  
Off

The water nozzle inside the cabinet allows the water nozzle (A) to be recessed against cabinet when not in use and to be extended outward when in use. To use the water dispenser, push the water nozzle (A) so it is fully extended. Place a cup against the paddle (B) and press to dispense water.



#### NOTE

**Optional:** Lock the water dispenser back in place by pushing the water nozzle back in when you have finished dispensing water.

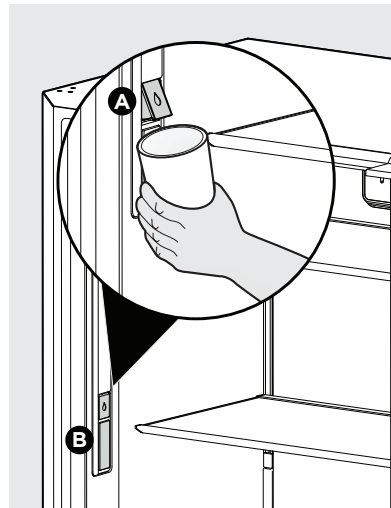

## Full Width Cantilever Shelves

You can move multi-position adjustable glass shelves to any position for larger or smaller packages. You may also remove and discard the shipping spacers stabilizing the shelves for shipping.

### To Adjust The Shelves

- Remove all food from the shelf.
- Shelves are heavy. We recommend using both hands to install and remove the shelf. Place one hand centered on the front trim and the other hand centered under the rear of the shelf.
- Lift the front edge up at a slight angle to release the tabs from the slots in the rear. Continue lifting the shelf vertically until the shelf clears the built-in shelf supports located on the sides of the cabinet. Then pull the shelf out.
- Replace the shelf by inserting the mounting bracket hooks into the desired support slots at the rear.
- Carefully lower the shelf and lock it into position.



### IMPORTANT

Carefully handle the shelves when removing and installing them to prevent making contact with the cabinet liners and the stainless steel rear air tower.

Do not block the air-flow vents located on the back wall of the air tower with the shelves.

## Slide-Out Shelf

The slide-out shelf can hold many different containers and food types for your convenience.



We recommend opening and closing the slide-out shelf by grabbing the shelf with a single hand in the middle of the shelf handle.

### To remove the slide-out shelf:

1. Remove all items from the shelf.
2. We recommend using both hands to remove and install the shelf from the slide rail supports. Remove the shelf by pulling it out until it is fully extended. Lift up on the front of the handle area and lift it out.
3. Carefully handle the shelf to prevent making contact with the cabinet liner during removal and installation.

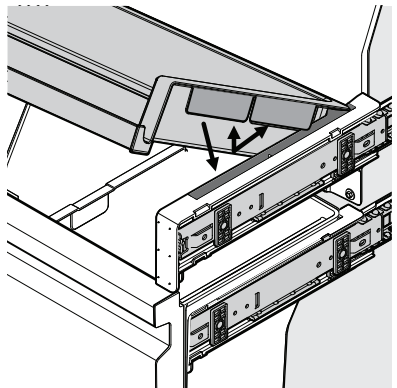

# 22 STORAGE FEATURES

---

## CrispSeal® Crisper with Auto Humidity and PureAir Produce Keeper™

The **CrispSeal Crisper with Auto Humidity** keeps produce fresher longer, so you waste less food and save money. It blocks dry air by maintaining the perfect amount of moisture while removing excess moisture. The crisper contains the **PureAir Produce Keeper** to ensure your produce stays fresher longer. For more information about your **PureAir Produce Keeper**, see **FILTER REPLACEMENT**.

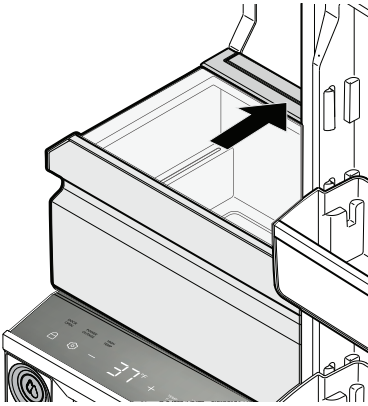

We recommend opening and closing the drawer by grabbing the center of the crisper handle.

### To remove the Crisper:

1. Remove all items from the crisper.
2. We recommend using both hands to install the crisper into the slide rail supports. Remove the crisper by pulling it out until it is fully extended. Lift up on the front of the handle area and lift it out.
3. Carefully handle the crisper to prevent making contact with the cabinet liner during removal and installation.

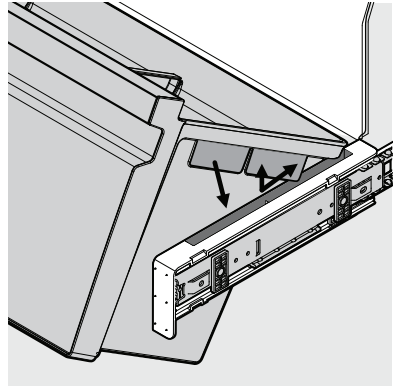

## Lower Drawer with Dividers

The lower drawer with dividers works great for food needing to be separated. Use the drawer with the dividers or without by removing or adding the inserts.

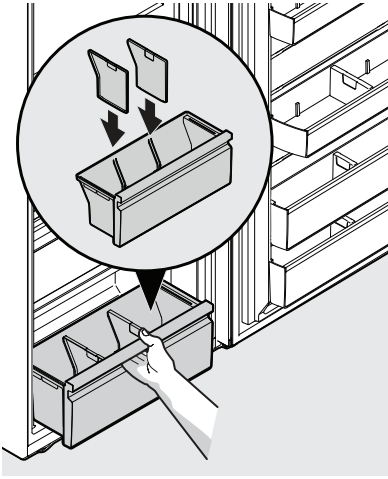

We recommend opening and closing the lower drawer by grabbing the center of the handle.

### To remove the lower drawer:

1. Remove all items from the lower drawer.
2. We recommend using both hands to remove and install the lower drawer from slide rail supports. Remove the drawer by pulling it out until it is fully extended. Lift up on the front of the handle trim and lift it out.
3. Carefully handle the drawer to prevent making contact with the cabinet liner during removal and installation.

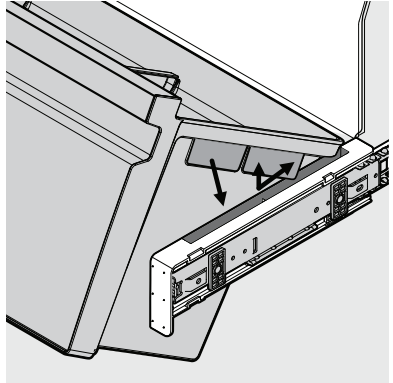

# 24 STORAGE FEATURES

---

## Adjustable Door Bins with Dividers

The adjustable door bins are specially designed to hold large containers or storage bags. You can use each bin type only in the zone indicated below so the door can close correctly. Your unit has two 2-Liter Door Bins (A), a Gallon Door Bin (B), and two Tall Item Door Bins (C).

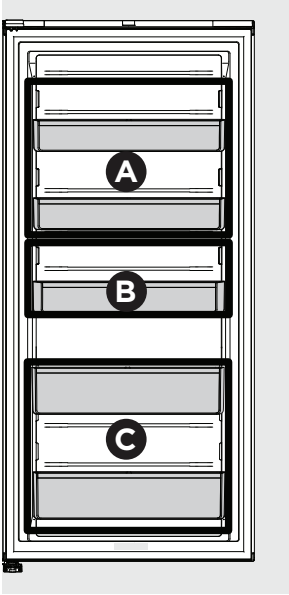

Use the bins with or without the dividers. Customize your unit to fit different sized items as your needs change with door bin dividers.

**To remove**, grasp the divider and pull it upward until it disengages with the door bin.

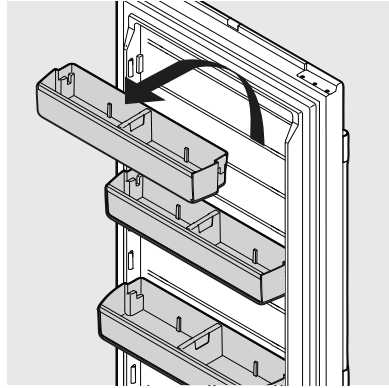

**To install**, slide the divider downward into the corresponding door bin alignment features until it is fully placed.

### To remove a door bin:

- Grasp the ends of the door bin.
- Lift the door bin up until it clears the locking lugs.
- Pull the door bin straight out toward you.

### To install a door bin:

- Make sure the locking feature on the bin aligns with the mounting lugs on the door.
- Lower the door bin into the mounting lugs until it locks in place.



- Locate the appliance in the coolest part of the room, out of direct sunlight, and away from heating ducts or registers. Do not place the unit next to heat-producing appliances such as a range, oven, or dishwasher. If this is not possible, a section of cabinetry or an added layer of insulation between the two appliances will help the unit operate more efficiently.
  - Level the appliance so the door closes tightly.
  - Refer to **CONTROLS AND SETTINGS** for the suggested temperature control settings.
  - Do not overcrowd the unit or block cold air vents. Doing so causes the appliance to run longer and use more energy.
  - Cover foods and wipe containers dry before placing them in the appliance. This cuts down on moisture build-up inside the unit.
  - Organize the appliance to reduce door openings. Remove as many items as needed at one time and close the door as soon as possible.
-

# 26 FILTER REPLACEMENT

## PurePour™ Water & Ice Filter

Keep safe, great-tasting water flowing with a **PurePour** water filter. Using a **Pure-Pour** water filter:

- **Makes Safe Water Second Nature**  
**PurePour** water filters are certified to reduce contaminants\* and keep great-tasting water flowing for you and your family.
- **Produces Purity You Can Trust**  
Know for certain your **PurePour** water filter is a protector. Counterfeits and knockoffs put your refrigerator and health at risk. Frigidaire Genuine Filters are the smarter, safer choice.
- **Every Drop Gives Back**  
Partnered on sustainability efforts, the use of a **PurePour** water filter helps cut back on the cost and use of plastic used to produce and package bottled water.

### Ordering your replacement water filter

If you have not used your refrigerator for a period of time (during moving for example), change the filter before reinstalling the refrigerator. Order replacement filters online at [Frigidaire.com](http://Frigidaire.com), by calling 1 (800) 374-4432 or through the dealer from which the refrigerator was purchased. We recommend replacing filters at least once every 6 months.

Here are the product numbers to request when ordering:

**PurePour™ Water & Ice Refrigerator Filter PWF-1™ FPPWFO1**



### NOTE

When you order your replacement filter, please reorder the same filter type currently in your refrigerator.

\*Find the [Performance Data Sheet](#) located in the **Guides and Manuals** section for your specific water filter on [Frigidaire.com](http://Frigidaire.com).

## More about your advanced water filter



Certified by IAPMO R&T against NSF/ANSI Standards 42, 53, 401, CSA B483.1 and NSF/ANSI/CAN 372 in PurePour PWF-1 systems for reduction of the claims on the Performance Data Sheet\*.

Do not use with water that is microbiologically unsafe or of unknown quality without adequate disinfection before or after the system. Use systems certified for cyst reduction on disinfected waters that may contain filterable cysts.

### Test & certification results:

- Rated Capacity - 125 gal/453 L for **PurePour** and ice and water filter
- Rated service flow - .50 gal/min.
- Operating Temp.: Min. 33°F, Max. 100°F
- Maximum Rated Pressure - 100 lbs/in.<sup>2</sup>
- Recommended Minimum Operating Pressure: 30 lbs/in.<sup>2</sup>

## Replacing your water filter

The water filter is located at the middle left side of the refrigerator compartment. In general, you should change the water filter every 6 months to ensure the highest possible water quality. **Water Filter Status** on the appliance control display prompts you to replace the filter after a standard amount of water (125 gal/453 L for **Pure-Pour**) has flowed through the system.

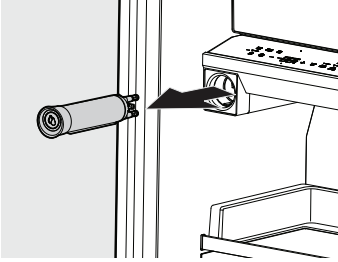

It is not necessary to turn the water supply off to change the filter. Be ready to wipe up any small amounts of water released during the filter replacement.

1. Remove the filter by firmly pressing the water filter cartridge until it releases. You will hear a click.
2. Slide the old water filter cartridge straight out of the housing and discard it.
3. Unpack the new filter cartridge. Using the alignment guide, slide it gently into the filter housing until it stops against the snap-in connector at the back of the housing.
4. Push firmly until the cartridge snaps into place (you should hear a click as the cartridge engages the snap-in connector).
5. Press a drinking glass against the water dispenser while checking for any leaks at the filter housing. Any spurts and sputters that occur as the system purges air out of the dispenser system are normal.
6. After filling one glass of water, continue flushing the system for about **4 minutes**.
7. Press and hold **WATER FILTER** on the appliance control display for 3 seconds. When the display changes from red to green, you have reset the status.

## PureAir Ultra II™ Air Filter

With more power to clear the air, Frigidaire air filters banish pungent smells and work better than baking soda. **PureAir Ultra II** Air Filters:

- **More powerful than baking soda**  
Keep your unit fresh for up to 6 months.
- **Captures & Keeps Odors Away**  
Absorbs undesirable smells with carbon technology.

Your appliance control display is equipped with a **REPLACE AIR FILTER** indicator to remind you to change your filter every 6 months to ensure optimal filtering of appliance odors. Your **PureAir Ultra II** Air Filter is included in your Literature Pack. To order replacement filters, please visit our online store at [Frigidaire.com](http://Frigidaire.com), by calling toll-free at 1 (800) 372-4432, or by visiting the dealer where you purchased your unit.

Here are the product numbers to request when ordering:

**PureAir Ultra II™ Air Filter PAULTRA2**

# 28 FILTER REPLACEMENT

---

## Replacing your air filter

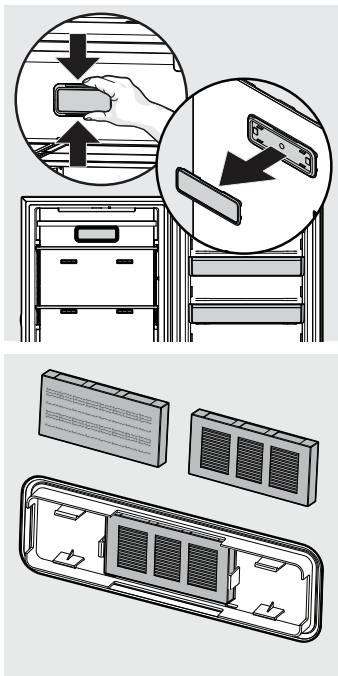

Your air filter housing is located in the upper rear center of the cabinet, behind a removable stainless steel decorative plate. To install the air filter element:

1. Grab the cover with your hand, pulling until it releases from the fixed air filter housing. The air filter element is mounted on the back of the cover.
2. If the filter was previously installed, remove the old filter and discard it.
3. Unpack the new filter and snap it into the filter cover. The open face (carbon media) of the filter should be installed facing outward in the cover.
4. Reattach the air filter cover to the air filter housing by aligning the cover to the housing and firmly pushing it until it snaps in place.
5. Press and hold **REPLACE AIR FILTER** on the appliance control display to reset it.

## PureAir Produce Keeper™

Keep fruits and vegetables fresher longer with **PureAir Produce Keeper**. Our produce keeper absorbs ethylene gas, the natural gas that causes produce to ripen quicker. Reduce food waste, save money and enjoy fresh-tasting produce with a longer storage life. Your **PureAir Produce Keeper** is included in your Literature Pack. To order replacements, please visit our online store at [Frigidaire.com](http://Frigidaire.com), by calling toll-free at 1 (800) 372-4432, or by visiting the dealer where you purchased your unit.

Here are the product numbers to request when ordering:

**PureAir Produce Keeper™ FRPAPKRF**

### Installing the PureAir Produce Keeper:

Your ethelene absorber holder is attached to the rear wall of the upper crisper. Remove it to install the **PureAir Produce Keeper**.

1. Fully extend the crisper for easy access. Grab the cover with your hand pulling until it releases from the crisper.
2. Remove the plastic wrapper. Insert the unopened packet into the holder in the crisper.
3. Reattach the Produce Keeper cover by aligning the cover and firmly pushing it until it snaps in place.
4. For optimal results, replace the refill every 6 months along with your air filter.



### CAUTION

**DO NOT OPEN.** Contents may irritate eyes or skin. Keep out of reach of children.

**FIRST AID:** Contains potassium permanganate. In case of contact with eyes or skin, rinse immediately with water.

**DO NOT EAT:** If swallowed, seek medical treatment immediately.

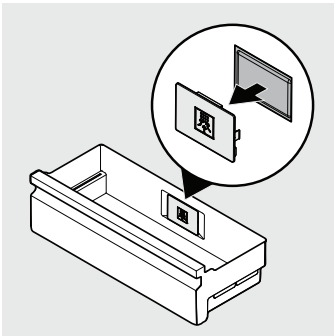
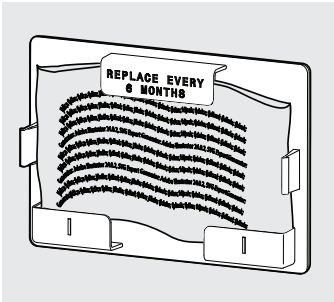

# 30 CARE AND CLEANING

---

## Protecting Your investment

Before cleaning your appliance, turn off power to your appliance by unplugging the power cord from the electrical outlet.

Keeping your appliance clean maintains appearance and prevents odor build-up. Wipe up any spills immediately and clean the appliance at least twice a year. When cleaning, take the following precautions:

- Never use CHLORIDE or cleaners with bleach to clean stainless steel.
- Do not wash any removable parts in a dishwasher.
- Always unplug the electrical power cord from the wall outlet before cleaning.
- Remove adhesive labels by hand. Do not use razor blades or other sharp instruments which can scratch the appliance surface.
- Do not remove the serial plate.

Do not use abrasive cleaners such as window sprays, scouring cleansers, brushes, flammable fluids, cleaning waxes, concentrated detergents, bleaches or cleansers containing petroleum products on plastic parts, interior doors, gaskets or cabinet liners. Do not use paper towels, metallic scouring pads, or other abrasive cleaning materials or strong alkaline solutions.



### CAUTION

- Pull the appliance straight out to move it. Shifting it from side to side may damage flooring.
- Damp objects stick to cold metal surfaces. Do not touch refrigerated surfaces with wet or damp hands.

## Vacation and Moving Tips

**Short Vacations:** Leave the unit operating during vacations of less than 3 weeks.

**Long Vacations:** If the appliance will not be used for several months:

- Remove all food and unplug the power cord.
- Clean and dry the interior thoroughly.
- Leave the door open slightly, blocking it open if necessary, to prevent odor and mold growth.

**Moving:** When moving the unit, follow these guidelines to prevent damage:

- Disconnect the power cord plug from the wall outlet.
- Secure all loose items such drawers and shelves by taping them securely in place to prevent damage.
- In the moving vehicle, secure unit in an upright position to prevent movement. Also protect outside of the appliance with a blanket, or similar item.



### NOTE

Do not use razor blades or other sharp instruments which can scratch the appliance surface when removing adhesive labels. Any glue left from tape or labels can be removed with a mixture of warm water and mild detergent, or, touch the glue residue with the sticky side of tape you have already removed. Do not remove the serial plate.

Care & Cleaning Tips		
Part	What To Use	Tips and Precautions
Interior & Door Liners	<ul style="list-style-type: none"> <li>• Soap and water</li> <li>• Baking soda and water</li> </ul>	Use 2 tbsp of baking soda in 1 qt of warm water. Be sure to wring excess water out of sponge or cloth before cleaning around controls, light bulb or any electrical part.
Door Gaskets	<ul style="list-style-type: none"> <li>• Soap and water</li> </ul>	Wipe gaskets with a clean soft cloth.
Drawers & Bins	<ul style="list-style-type: none"> <li>• Soap and water</li> </ul>	Use a soft cloth to clean drawer runners and tracks. Do not wash any removable items (bins, drawers, etc.) in dishwasher.
Glass Shelves	<ul style="list-style-type: none"> <li>• Soap and water</li> <li>• Glass cleaner</li> <li>• Mild liquid sprays</li> </ul>	Allow glass to warm to room temperature before immersing in warm water.
Exterior & Handles	<ul style="list-style-type: none"> <li>• Soap and water</li> <li>• Non-Abrasive Glass Cleaner</li> </ul>	Do not use commercial household cleaners, ammonia, or alcohol to clean handles. Use a soft cloth to clean smooth handles. Do not use a dry cloth to clean smooth doors.
<b>Exterior &amp; Handles (Stainless Steel Models Only)</b>	<ul style="list-style-type: none"> <li>• Soap and water</li> <li>• Ammonia</li> <li>• Stainless Steel Cleaners</li> </ul>	<p>Never use CHLORIDE to clean stainless steel. Clean stainless steel front and handles with non-abrasive soapy water and a dishcloth. Rinse with clean water and a soft cloth. Wipe stubborn spots with an ammonia-soaked paper towel, and rinse. Use a non-abrasive stainless steel cleaner. These cleaners can be purchased at most home improvement or major department stores. Always follow manufacturer's instruction.</p> <p><b>NOTE:</b> Always, clean, wipe and dry with grain to prevent cross-grain scratching. Wash the rest of the cabinet with warm water and mild liquid detergent. Rinse well, and wipe dry with a clean soft cloth.</p>

# 32 TROUBLESHOOTING

Let us help you troubleshoot your concern! This section will help you with common issues. If you need us, visit our website, chat with an agent, or call us. We may be able to help you avoid a service visit. If you do need service, we can get that started for you!

**1-800-374-4432 (United States)**

**1-800-265-8352 (Canada)**

**Frigidaire.com**

**Frigidaire.ca**

CONCERN	CAUSE	SOLUTION
<b>APPLIANCE OPERATION</b>		
<b>Appliance does not run.</b>	<ul style="list-style-type: none"> <li>• Appliance is plugged into a tripped Ground Fault Interrupt (GFI).</li> <li>• Appliance may not be plugged in or plug is loose.</li> <li>• House fuse blown or tripped circuit breaker.</li> <li>• Power outage.</li> </ul>	<ul style="list-style-type: none"> <li>• Appliance must be plugged into a dedicated circuit with standard outlet. Contact a certified electrician to check.</li> <li>• Ensure plug is tightly pushed into outlet.</li> <li>• Check/replace fuse with a 15-amp time-delay fuse. Reset circuit breaker.</li> <li>• Check house lights. Call the local electric company.</li> </ul>
<b>Appliance temperature is warmer than preferred.</b>	<ul style="list-style-type: none"> <li>• The appliance temperature is set too high.</li> <li>• Items are blocking the multi-port air flow system, which may affect cooling performance.</li> </ul>	<ul style="list-style-type: none"> <li>• Set control to a colder setting until appliance temperature is satisfactory. Allow 24 hours for the temperature to stabilize.</li> <li>• Make sure the items are not placed directly in front of the cold air exhaust ports.</li> </ul>
<b>Appliance is noisy or vibrates.</b>	<ul style="list-style-type: none"> <li>• The cabinet is not level.</li> <li>• Floor is weak.</li> </ul>	<ul style="list-style-type: none"> <li>• Adjust the leveling feet. See <b>Leveling</b> in the <b>INSTALLATION</b> section.</li> </ul>
<b>Appliance runs too much or too long.</b>	<ul style="list-style-type: none"> <li>• Room or outside weather is hot.</li> <li>• Appliance has recently been disconnected for a period of time.</li> <li>• Large amounts of warm or hot food have been stored recently.</li> <li>• Door is opened too frequently or too long.</li> <li>• Door may be slightly open.</li> <li>• Temperature control is set too low.</li> <li>• Gaskets are dirty, worn, cracked, or poorly fitted.</li> </ul>	<ul style="list-style-type: none"> <li>• It's normal for the appliance to work longer under these conditions.</li> <li>• It takes 24 hours for the appliance to cool down completely.</li> <li>• Warm food will cause appliance to run more until the desired temperature is reached.</li> <li>• Warm air entering the appliance causes it to run more. Open door less often.</li> <li>• See <b>DOOR PROBLEMS</b> in <b>TROUBLESHOOTING</b> section.</li> <li>• Turn control knob to a warmer setting. Allow several hours for the temperature to stabilize.</li> <li>• Clean or change gasket. (See <b>Care and Cleaning Tips</b> in the <b>CARE AND CLEANING</b> section). Worn, cracked or poorly fitting gaskets should be replaced.</li> </ul>
<b>APPLIANCE TEMPERATURES</b>		
<b>Interior appliance temperature is too cold.</b>	<ul style="list-style-type: none"> <li>• Temperature control is set too low.</li> </ul>	<ul style="list-style-type: none"> <li>• Set control to a warmer setting. Allow several hours for temperature to stabilize.</li> </ul>

CONCERN	CAUSE	SOLUTION
<b>APPLIANCE TEMPERATURES (cont'd)</b>		
<b>Temperature inside appliance is too warm.</b>	<ul style="list-style-type: none"> <li>• Temperature control is set too warm.</li> <li>• Door is opened too frequently or too long.</li> <li>• Door may not be seating properly.</li> <li>• Large amount of warm or hot food has been stored recently.</li> <li>• Unit has recently been disconnected for a period of time.</li> </ul>	<ul style="list-style-type: none"> <li>• Turn control to a colder setting. Allow several hours for temperature to stabilize.</li> <li>• Warm air enters the appliance every time the door is opened. Open door less often.</li> <li>• Look for food items on the shelves or in the door bins keeping the door from closing completely.</li> <li>• Wait until the appliance has had a chance to reach its selected temperature.</li> <li>• Appliance may take up to 24 hours to cool down completely.</li> </ul>
<b>🔒 is displayed on control.</b>	<ul style="list-style-type: none"> <li>• The control has been locked.</li> </ul>	<ul style="list-style-type: none"> <li>• Press 🔒 for 3 seconds to unlock.</li> </ul>
<b>Sb is displayed on the control.</b>	<ul style="list-style-type: none"> <li>• The control is in Sabbath Mode.</li> </ul>	<ul style="list-style-type: none"> <li>• Press — and <b>TEMP F/C</b> for 5 seconds.</li> </ul>
<b>DEMO is displayed in the control.</b>	<ul style="list-style-type: none"> <li>• The control is in <b>DEMO</b> mode. Cooling has stopped functioning.</li> </ul>	<ul style="list-style-type: none"> <li>• To exit <b>DEMO</b> mode, simultaneously press and hold — and <b>WATER FILTER</b> for 10 seconds.</li> </ul>
<b>SOUND AND NOISE</b>		
<b>Louder sound levels whenever appliance is on.</b>	<ul style="list-style-type: none"> <li>• Modern appliances have increased storage capacity and more stable temperatures. They require heavy-duty compressors.</li> </ul>	<ul style="list-style-type: none"> <li>• This is normal. When the surrounding noise level is low, you might hear the compressor running while it cools the interior.</li> </ul>
<b>Popping or cracking sound when compressor comes on. Bubbling or gurgling sound.</b>	<ul style="list-style-type: none"> <li>• Metal parts undergo expansion and contraction, as in hot water pipes.</li> <li>• Refrigerant (used to cool refrigerator) is circulating throughout the system.</li> </ul>	<ul style="list-style-type: none"> <li>• This is normal. Sound will level off or disappear as appliance continues to run.</li> <li>• This is normal.</li> </ul>
<b>Vibrating or rattling noise.</b>	<ul style="list-style-type: none"> <li>• Appliance is not level. It rocks on the floor when it is moved slightly.</li> <li>• Floor is uneven or weak.</li> <li>• Appliance is touching the wall.</li> </ul>	<ul style="list-style-type: none"> <li>• Level the appliance. Refer to <b>Leveling</b> in the <b>INSTALLATION</b> section.</li> <li>• Ensure floor can adequately support the appliance. Level the appliance by putting wood or metal shims under part of the appliance.</li> <li>• Re-level appliance or move appliance slightly. Refer to <b>Leveling</b> in the <b>INSTALLATION</b> section.</li> </ul>

# 34 TROUBLESHOOTING

CONCERN	CAUSE	SOLUTION
<b>WATER / MOISTURE / FROST INSIDE APPLIANCE</b>		
<b>Moisture forms on inside appliance walls.</b>	<ul style="list-style-type: none"> <li>Weather is hot and humid, which increases internal rate of frost buildup.</li> <li>Door is slightly open.</li> <li>Door is kept open too long.</li> </ul>	<ul style="list-style-type: none"> <li>This is normal.</li> <li>Look for food items on the shelves or in the door bins keeping the door from closing completely.</li> <li>Open the door less often.</li> </ul>
<b>ODOR IN APPLIANCE</b>		
<b>Odors in appliance.</b>	<ul style="list-style-type: none"> <li>Interior needs to be cleaned.</li> <li>Foods with strong odors are in the appliance.</li> <li>The air filter needs to be replaced.</li> </ul>	<ul style="list-style-type: none"> <li>Clean interior with sponge, warm water, and baking soda. Replace air filter.</li> <li>Cover the food tightly.</li> <li>Refer to <b>PureAir Ultra II Air Filter</b> the in <b>FILTER REPLACEMENT</b> section.</li> </ul>
<b>DOOR PROBLEMS</b>		
<b>Door will not close.</b>	<ul style="list-style-type: none"> <li>Appliance is not level. It rocks on the floor when it is moved slightly.</li> <li>Floor is uneven or weak.</li> </ul>	<ul style="list-style-type: none"> <li>This condition can force the cabinet out of square and misalign the door. Refer to <b>Leveling</b> in the <b>INSTALLATION</b> section.</li> <li>Ensure floor can adequately support appliance. Level the appliance by putting wood or metal shims under part of the appliance.</li> <li>Look for food items on the shelves or in the door bins keeping the door from closing completely.</li> </ul>
<b>LIGHTING PROBLEMS</b>		
<b>Cabinet light is not working.</b>	<ul style="list-style-type: none"> <li>LED has burned out.</li> </ul>	<ul style="list-style-type: none"> <li>Call a Frigidaire service technician.</li> </ul>

# LIMITED WARRANTY **35**

Your appliance is covered by a two-year limited warranty. For two years from your date of delivery, Electrolux will pay all costs for repairing or replacing any parts of this appliance that prove to be defective in materials or workmanship when such appliance is installed, used and maintained in accordance with the provided instructions.

## **Exclusions**

### **This warranty does not cover the following:**

1. Products with original serial numbers that have been removed, altered or cannot be readily determined.
2. Product that has been transferred from its original owner to another party or removed outside the USA or Canada.
3. Rust on the interior or exterior of the unit.
4. Products purchased "as-is" are not covered by this warranty.
5. Food loss due to any Appliance or freezer failures.
6. Products used in a commercial setting.
7. Service calls which do not involve malfunction or defects in materials or workmanship, or for appliances not in ordinary household use or used other than in accordance with the provided instructions.
8. Service calls to correct the installation of your appliance or to instruct you how to use your appliance.
9. Expenses for making the appliance accessible for servicing, such as removal of trim, cupboards, shelves, etc., which are not a part of the appliance when it is shipped from the factory.
10. Service calls to repair or replace appliance light bulbs, air filters, water filters, other consumables, or knobs, handles, or other cosmetic parts.
11. Surcharges including, but not limited to, any after hour, weekend, or holiday service calls, tolls, ferry trip charges, or mileage expense for service calls to remote areas, including the state of Alaska.
12. Damages to the finish of appliance or home incurred during installation, including but not limited to floors, cabinets, walls, etc.
13. Damages caused by: services performed by unauthorized service companies; use of parts other than genuine Electrolux parts or parts obtained from persons other than authorized service companies; or external causes such as abuse, misuse, inadequate power supply, accidents, fires, or acts of God.

## **DISCLAIMER OF IMPLIED WARRANTIES; LIMITATION OF REMEDIES**

CUSTOMER'S SOLE AND EXCLUSIVE REMEDY UNDER THIS LIMITED WARRANTY SHALL BE PRODUCT REPAIR OR REPLACEMENT AS PROVIDED HEREIN. CLAIMS BASED ON IMPLIED WARRANTIES, INCLUDING WARRANTIES OF MERCHANTABILITY OR FITNESS FOR A PARTICULAR PURPOSE, ARE LIMITED TO ONE YEAR OR THE SHORTEST PERIOD ALLOWED BY LAW, BUT NOT LESS THAN ONE YEAR. ELECTROLUX SHALL NOT BE LIABLE FOR CONSEQUENTIAL OR INCIDENTAL DAMAGES SUCH AS PROPERTY DAMAGE AND INCIDENTAL EXPENSES RESULTING FROM ANY BREACH OF THIS WRITTEN LIMITED WARRANTY OR ANY IMPLIED WARRANTY. SOME STATES AND PROVINCES DO NOT ALLOW THE EXCLUSION OR LIMITATION OF INCIDENTAL OR CONSEQUENTIAL DAMAGES, OR LIMITATIONS ON THE DURATION OF IMPLIED WARRANTIES, SO THESE LIMITATIONS OR EXCLUSIONS MAY NOT APPLY TO YOU. THIS WRITTEN WARRANTY GIVES YOU SPECIFIC LEGAL RIGHTS. YOU MAY ALSO HAVE OTHER RIGHTS THAT VARY FROM STATE TO STATE.

## **If You Need Service**

Keep your receipt, delivery slip, or some other appropriate payment record to establish the warranty period should service be required. If service is performed, it is in your best interest to obtain and keep all receipts. Service under this warranty must be obtained by contacting Electrolux at the addresses or phone numbers below.

This warranty only applies in the USA and Canada. In the USA, your appliance is warranted by Electrolux Major Appliances North America, a division of Electrolux Home Products, Inc. In Canada, your appliance is warranted by Electrolux Canada Corp. Electrolux authorizes no person to change or add to any obligations under this warranty. Obligations for service and parts under this warranty must be performed by Electrolux or an authorized service company. Product features or specifications as described or illustrated are subject to change without notice.

## **USA**

**1-800-374-4432**

Frigidaire

10200 David Taylor Drive  
Charlotte, NC 28262



**Electrolux**

## **Canada**

**1.800.265.8352**

Electrolux Canada Corp.

5855 Terry Fox Way

Mississauga, Ontario, Canada  
L5V 3E4

# FRIGIDAIRE®

welcome **home**

Our home is your home. Visit us if you need help with any of these things:



owner support



accessories



service



registration

(See your registration card for more information.)

Frigidaire.com  
1-800-374-4432

Frigidaire.ca  
1-800-265-8352