

OPERATION AND INSTALLATION INSTRUCTIONS MANUAL

DUCTED AIR-CONDITIONING UNIT (7.0-14.0kW)

English

عربي

Unit Model:

Indoor unit

FDM24PEVLK
FDM30PEVLK
FDM36PEVLK
FDM42PEVLK
FDM48PEVLK
FDYM24PEVLK
FDYM30PEVLK
FDYM36PEVLK
FDYM42PEVLK
FDYM48PEVLK

Outdoor unit

R24PEVLK
R30PEVLK
R36PEVLK
R42PETLK/R42PEYLK
R48PETLK/R48PEYLK
RY24PEVLK
RY30PEVLK
RY36PEVLK
RY42PETLK/RY42PEYLK
RY48PETLK/RY48PEYLK

User Notice

- ☆ **Ensure unified power supply for each indoor unit.**
- ☆ **Never install wired controller in wet place or under sunlight directly.**
- ☆ **Shielding twisted pair line must be adopted as signal line or wiring (communication) of wired controller once the unit is installed in the place where there is electromagnetic interference.**
- ☆ **Make sure communication line is connected into correct port to avoid communication error.**
- ☆ **Never knock, throw or frequently disassemble the wired controller.**
- ☆ **Never operate the wired controller with wet hand.**

Contents

I	SAFETY PRECAUTIONS	2
II	DISPLAYING PART	6
	2.1 LCD Display of Wired Controller	6
	2.2 Instruction to LCD Display	7
III	BUTTONS	8
	3.1 Silk Screen of Buttons	8
	3.2 Instruction to Function of Buttons	8
IV	INSTALLATION OF WIRED CONTROLLER	9
V	INSTRUCTION TO OPERATION	10
	5.1 On/Off	10
	5.2 Mode Setting	10
	5.3 Temperature Setting	11
	5.4 Fan Speed Setting	11
	5.5 Swing Control Function*	12
	5.6 Timer Setting	12
	5.7 Air Exchange Setting*	14
	5.8 Sleep Setting	15
	5.9 Turbo Function Setting	16
	5.10 Save Function Setting	16
	5.11 E-heater Setting*	18
	5.12 Blow Function Setting	19
	5.13 Quiet Function Setting	20
	5.14 Field Setting	20
	5.15 Other Functions	21
VI	ERROR DISPLAY	22
VII	SETTING OF INDOOR ROOM SENSOR	23
	7.1 Setting of Double Indoor Room Sensors	23
	7.2 Fresh Air Control*	23
	7.3 The head of delivery of the condensate drainage pump*	24
VIII	DIMENSIONS OF INDOOR UNIT AND OUTDOOR UNIT	25
	8.1 Dimensions of Indoor Unit	25
	8.2 Dimensions of Outdoor Unit	26
IX	INSTALLATION INSTRUCTIONS	27
	9.1 Precautions on Installation of Outdoor Unit	27
	9.2 Precautions on Installation of Indoor Unit	27
	9.3 Level Check of the Indoor Unit	29
	9.4 Installation of Rectangular Air Pipe	29
	9.5 Installation of Drainage Pipeline	30
	9.6 Testing of Drainage System	30
	9.7 Selection of the Refrigerant Pipe	31
	9.8 Connection of the Refrigerant Pipe	31
	9.9 Installation of Protective Layer of the Refrigerant Pipe	35
	9.10 Position and Method of Installing Wired Controller	36
	9.11 Electric Installation	37
	9.12 Cable Connecting Diagram	41
	9.13 Troubleshooting and Maintenance	44
X	SPECIFICATIONS	47

Notes: The functions with * are reserved for other models and are not applicable for the models listed in this manual.

I SAFETY PRECAUTIONS

To gain full advantage of the air conditioner's functions and to avoid malfunction due to mishandling, we recommend that you read this instruction manual carefully before use.

This air conditioner is classified under "appliances not accessible to the general public".

Please read these "SAFETY PRECAUTIONS" carefully before installing air conditioning equipment and be sure to install it correctly.

After completing installation, conduct a trial operation to check for faults and explain to the user how to operate the air conditioner and take care of it with the aid of the operation manual. Ask the user to store the installation manual along with the operation manual for future reference.

The precautions described herein are classified as WARNING and CAUTION. They both contain important information regarding safety. Be sure to observe all precautions without fail.

Meaning of WARNING and CAUTION notices.



WARNING Failure to follow these instructions properly may result in personal injury or loss of life.



CAUTION Failure to observe these instructions properly may result in property damage or personal injury, which may be serious depending on the circumstances.

After reading, keep this manual in a convenient place so that you can refer to it whenever necessary. If the equipment is transferred to a new user, be sure also to hand over the manual.



WARNING

- Be aware that prolonged, direct exposure to cool or warm air from the air conditioner, or to air that is too cool or too warm can be harmful to your physical condition and health.
- When the air conditioner is malfunctioning (giving off a burning odour, etc.) turn off power supply to the unit and contact our local dealer.
Continued operation under such circumstances may result in a failure, electric shocks or fire hazards.
- Consult our local dealer about installation work.
Doing the work yourself may result in water leakage, electric shocks or fire hazards.
- Consult our local dealer regarding modification, repair and maintenance of the air conditioner.
Improper workmanship may result in water leakage, electric shocks or fire hazards.
- Do not place objects, including rods, your fingers, etc., in the air inlet or outlet.
Injury may result due to contact with the air conditioner's highspeed fan blades.
- Be ware of fire in case of refrigerant leakage.
If the air conditioner is not operating correctly, i.e. not generating cool or warm air, refrigerant leakage could be the cause.
Consult our dealer for assistance.
The refrigerant within the air conditioner is safe and normally does not leak.
However, in the event of a leakage, contact with a naked burner, heater or cooker may result in generation of noxious gas.
Do not use the air conditioner any longer until a qualified service person confirms that the leakage has been repaired.
- Consult our local dealer regarding what to do in case of refrigerant leakage.
When the air conditioner is to be installed in a small room, it is necessary to take proper measures so that the amount of any leaked refrigerant does not exceed the concentration limit in the event of a leakage.
Otherwise, this may lead to an accident due to oxygen depletion.
- Contact professional personnel about attachment of accessories and be sure to use only accessories specified by the manufacturer.
If a defect results from your own workmanship, it may result in water leaks, electric shock or fire.
- Consult our local dealer regarding relocation and reinstallation of the air conditioner.
Improper installation work may result in leakage, electric shocks or fire hazards.
- Be sure to use fuses with the correct ampere reading.
Do not use improper fuses, copper or other wires as a substitute, as this may result in electric shock, fire, injury or damage to the unit.

- Be sure to earth the unit.
Do not earth the unit to a utility pipe, lightning conductor or telephone earth lead. Imperfect earthing may result in electric shocks or fire.
A high surge current from lightning or other sources may cause damage to the air conditioner.
 - Be sure to install an earth leakage breaker.
Failure to install an earth leakage breaker may result in electric shocks or fire.
 - Consult the dealer if the air conditioner submerges owing to a natural disaster, such as a flood or typhoon.
Do not operate the air conditioner in that case, otherwise a malfunction, electric shock, or fire may result.
 - Do not start or stop operating the air conditioner with the power supply breaker turned ON or OFF.
Otherwise fire or water leakage may result. Furthermore, the fan will rotate abruptly if power failure compensation is enabled, which may result in injury.
 - Do not use the product in the atmosphere contaminated with oil vapor, such as cooking oil or machine oil vapor.
Oil vapor may cause crack damage, electric shocks, or fire.
 - Do not use the product in places with excessive oily smoke, such as cooking rooms, or in places with flammable gas, corrosive gas, or metal dust.
Using the product in such places may cause fire or product failures.
 - Do not use flammable materials (e.g., hairspray or insecticide) near the product.
Do not clean the product with organic solvents such as paint thinner.
The use of organic solvents may cause crack damage to the product, electric shocks, or fire.
 - Be sure to use a dedicated power supply for the air conditioner.
The use of any other power supply may cause heat generation, fire, or product failures.
 - Ask our dealer or qualified personnel to carry out installation work.
Do not attempt to install the air conditioner yourself. Improper installation may result in water leakage, electric shocks or fire.
 - Install the air conditioner in accordance with the instructions of this installation manual.
Improper installation may result in water leakage, electric shocks or fire.
 - Be sure to use only the specified accessories and parts for installation work.
Failure to use the specified parts may result in the unit falling, water leakage, electric shocks or fire.
 - Install the air conditioner on a foundation strong enough to withstand the weight of the unit.
A foundation of insufficient strength may result in the equipment falling and causing injury.
 - Carry out the specified installation work after taking into account strong winds, typhoons or earthquakes.
Failure to do so during installation work may result in the unit falling and causing accidents.
 - Make sure that a separate power supply circuit is provided for this unit and that all electrical work is carried out by qualified personnel according to local laws and regulations and this installation manual.
An insufficient power supply capacity or improper electrical construction may lead to electric shocks or fire.
 - Make sure that all wiring is secured, the specified wires are used, and that there is no strain on the terminal connections or wires.
Improper connections or securing of wires may result in abnormal heat build-up or fire.
 - When wiring the power supply and connecting the wiring between the indoor and outdoor units, position the wires so that the control box lid can be securely fastened.
Improper positioning of the control box lid may result in electric shocks, fire or overheating terminals.
 - If refrigerant gas leaks during installation, ventilate the area immediately.
Toxic gas may be produced if the refrigerant comes into contact with fire.
 - After completing installation, check for refrigerant gas leakage.
Toxic gas may be produced if the refrigerant gas leaks into the room and comes into contact with a source of fire, such as a fan heater, stove or cooker.
 - Be sure to cut off the power supply before touching any electrical parts.
-



CAUTION

- Do not use the air conditioner for purposes other than those for which it is intended.
Do not use the air conditioner for cooling precision instruments, food, plants, animals or works of art as this may adversely affect the performance, quality and/or longevity of the object concerned.
- Do not remove the outdoor unit's fan guard.
The guard protects against the unit's high speed fan, which may cause injury.
- Do not place objects that are susceptible to moisture directly beneath the indoor or outdoor units.
Under certain conditions, condensation on the main unit or refrigerant pipes, air filter dirt or drain blockage may cause dripping, resulting in fouling or failure of the object concerned.
- To avoid oxygen depletion, ensure that the room is adequately ventilated if equipment such as a burner is used together with the air conditioner.
- After prolonged use, check the unit stand and its mounting situation
If left in a damaged condition, the unit may fall and cause injury.
- Do not place flammable sprays or operate spray containers near the unit as this may result in fire.
- Before cleaning, be sure to stop unit operation, turn the breaker off or remove the power cord.
Otherwise, an electric shock and injury may result.
- To avoid electric shocks, do not operate with wet hands.
- Do not place appliances that produce naked flames in places exposed to the air flow from the unit as this may impair combustion of the burner.
- Do not place heaters directly below the unit, as resulting heat can cause deformation.
- Do not allow a child to mount on the outdoor unit, do not place any object on it.
Falling or tumbling may result in injury.
- Do not block air inlets or outlets.
Impaired air flow may result in insufficient performance or trouble.
- Be sure that children, plants or animals are not exposed directly to airflow from the unit, as adverse effects may ensue.
- Do not wash the air conditioner with water, as this may result in electric shocks or fire.
- Do not install the air conditioner at any place where there is a danger of flammable gas leakage.
In the event of a gas leakage, build-up of gas near the air conditioner may result in fire hazards.
- Do not put flammable containers, such as spray cans, within 1m from the air outlet.
The containers may explode because the warm air output of the indoor or outdoor unit will affect them.
- Arrange the drain to ensure complete drainage.
If proper drainage from the outdoor drain pipe does not occur during air conditioner operation, there could be a blockage due to dirt and debris build-up in the pipe.
This may result in a water leakage from the indoor unit.
Under these circumstances, stop air conditioner operation and consult our dealer for assistance.
- The appliance is not intended for use by unattended young children or infirm persons.
Impairment of bodily functions and harm to health may result.
- Children should be supervised to ensure that they do not play with the unit or its remote controller.
Accidental operation by a child may result in impairment of bodily functions and harm health.
- Do not let children play on or around the outdoor unit.
If they touch the unit carelessly, injury may be caused.
- Consult our dealer regarding cleaning the inside of the air conditioner.
Improper cleaning may cause breakage of plastic parts, water leakage and other damage as well as electric shocks.
- To avoid injury, do not touch the air inlet or aluminium fins of the unit.
- Do not place objects in direct proximity of the outdoor unit and do not let leaves and other debris accumulate around the unit.
Leaves are a hotbed for small animals which can enter the unit. Once get in the unit, such animals can cause malfunctions, smoke or fire when making contact with electrical parts.
- Never touch the internal parts of the controller.
Do not remove the front panel. Touching certain internal parts will cause electric shocks and damage to the unit. Please consult our dealer about checking and adjustment of internal parts.
- Do not leave the remote controller wherever there is a risk of wetting.
If water gets into the remote controller there is a risk of electrical leakage and damage to electronic components.

- Watch your steps at the time of taking out or put back the air filter for cleaning or inspection.
High-place work is required, to which utmost attention must be paid.
If the scaffold is unstable, you may fall or topple down, thus causing injury.
 - While following the instructions in this installation manual, install drain piping to ensure proper drainage and insulate piping to prevent condensation.
Improper drain piping may result in indoor water leakage and property damage.
 - Install the indoor and outdoor units, power cord and connecting wires at least 1 meter away from televisions or radios to prevent picture interference and noise.
(Depending on the incoming signal strength, a distance of 1 meter may not be sufficient to eliminate noise.)
 - Remote controller (wireless) transmitting distance can be shorter than expected in rooms with electronic fluorescent lamps (inverter or rapid start types).
Install the indoor unit as far away from fluorescent lamps as possible.
 - Do not install the air conditioner in the following locations:
 1. Where there is a high concentration of mineral oil spray or vapour (e.g. a kitchen).
Plastic parts will deteriorate, parts may fall off and water leakage could result.
 2. Where corrosive gas, such as sulphurous acid gas, is produced.
Corroding of copper pipes or soldered parts may result in refrigerant leakage.
 3. Near machinery emitting electromagnetic radiation.
Electromagnetic radiation may disturb the operation of the control system and result in a malfunction of the unit.
 4. Where flammable gas may leak, where there is carbon fibre or ignitable dust suspensions in the air, or where volatile flammables such as paint thinner or gasoline are handled.
Operating the unit in such conditions may result in fire.
-

II DISPLAYING PART



Fig.2.1 Outline of wired controller

2.1 LCD Display of Wired Controller



Fig.2.2 LCD display

2.2 Instruction to LCD Display

No.	Description	Instruction to Displaying Contents
1	Swing*	Swing function
2	Air*	Air exchange function
3	Sleep	Sleeping states
4	Running mode	Each kind of running mode of indoor unit (auto mode)
5	Cooling	Cooling mode
6	Dry	Dry mode
7	Fan	Fan
8	Heating	Heating mode
9	Defrost*	Defrosting state
10	Gate-control card*	Gate control
11	Lock	Lock state
12	Shield	Shielding state (buttons, temperature, on/off, mode or save is shielded by long-distance monitoring)
13	Turbo	Turbo function state
14	Memory	Memory state (Indoor unit resumes original setting state after power failure and then power recovery)
15	Twinkle	Flicking when unit is on without operation of buttons
16	Save	Energy-saving state
17	Temperature	Ambient/setting temperature value
18	E-Heater*	E-HEATING display means electric-heater is available
19	Blow	Blow mark
20	Timer	Timer-displayed location
21	Quiet	Quiet state (two types: quiet and auto quiet)
<p>Notes: The functions with * are reserved for other models and are not applicable for the models listed in this manual.</p>		

Table.2.1

III BUTTONS

3.1 Silk Screen of Buttons

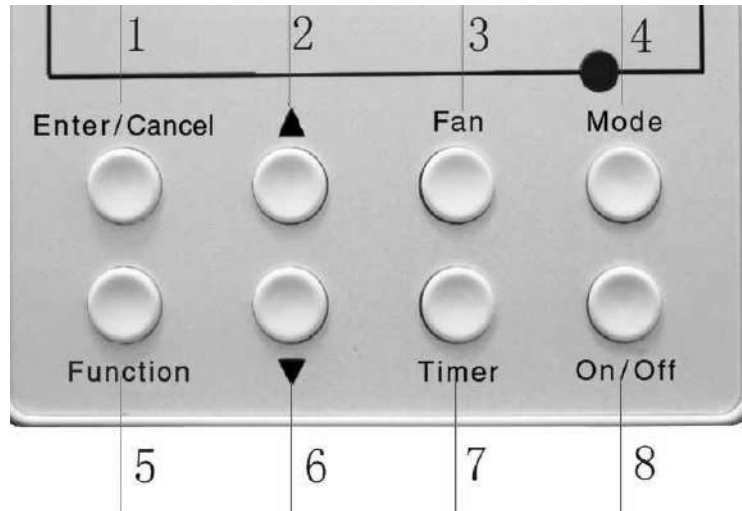

Fig.3.1 Silk screen of buttons

3.2 Instruction to Function of Buttons

No.	Description	Function of Button
1	Enter/Cancel	(1) Function selection and canceling; (2) Press it for 5s to enquiry the outdoor ambient temperature.*
2	▲	(1) Running temperature setting of indoor unit, range :16 ~ 30°C
6	▼	(2) Timer setting, range:0.5-24hr (3) Switchover between quiet/auto quiet
3	Fan	Setting of high/middle/low/auto fan speed
4	Mode	Setting of cooling/heating/fan/dry mode of indoor unit
5	Function	Switchover among the functions of air/sleep/turbo/save/E-heater/blow/quiet
7	Timer	Timer setting
8	On/off	Turn on/off indoor unit
4 Mode and 2 ▲	Memory function	Press Mode and ▲ for 5s under off-state of the unit to enter/cancel key memory function (If memory is set, indoor unit will resume original setting state after power failue and then power recovery. If not, indoor unit is defaulted to be off after power recovery. Memory function is defaulted to be off before outgoing.)
2 ▲ and 6 ▼	Lock	Upon startup of the unit without malfunction or under off-state of the unit, press ▲ and ▼ at the same time for 5s into lock state. In this case, any other buttons won't respond the press. Repress ▲ and ▼ for 5s to quit lock state.

Table.3.1

IV INSTALLATION OF WIRED CONTROLLER

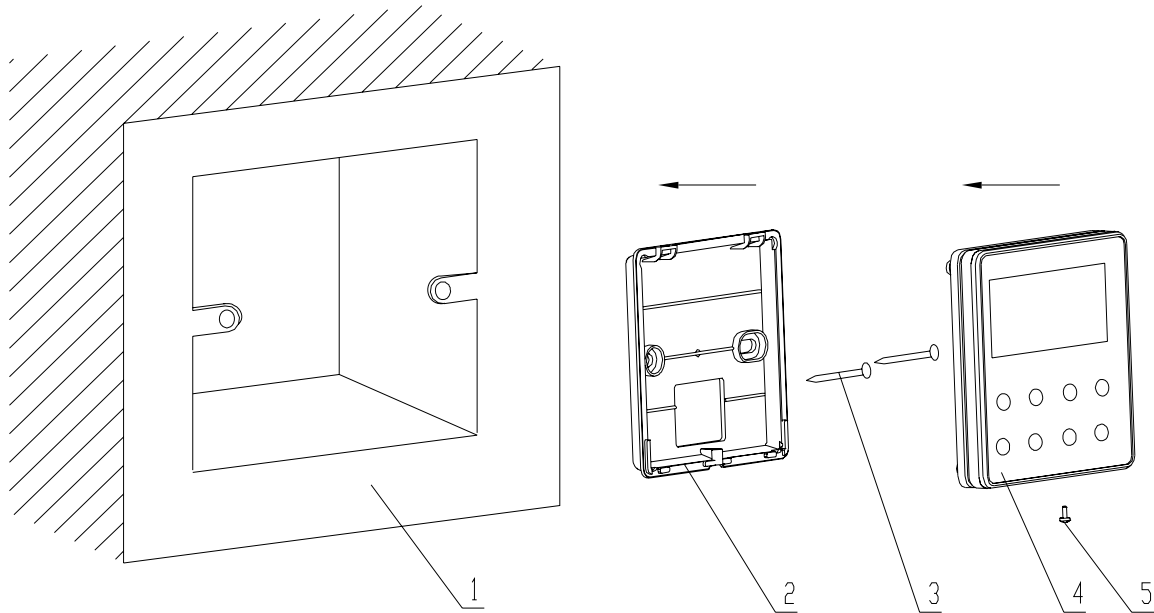

Fig.4.1 Sketch for Installation of Wired Controller

No.	1	2	3	4	5
Description	Socket's base box installed in the wall	Soleplate of controller	Screw M4X25	Front panel of controller	Screw ST2.2X6.5

Fig.4.1: Sketch for Installation of Wired Controller. Pay attention to the following items during the installation of wired controller:

1. Cut off power supply before installation. It is prohibited to perform the whole procedure with electricity.
2. Pull out 4-core twisted pair line in mounting hole and then make it through the rectangle hole at the back of controller's soleplate.
3. Joint the controller's soleplate on wall face and then fix it in mounting hole with screws M4X25.
4. Insert the 4-core twisted pair into controller's slot through rectangle hole and buckle the front panel and soleplate of controller together.
5. At last, fix the controller's front panel and soleplate with screws ST2.2X6.5.

⚠ CAUTION

During connection of wirings, pay special attention to the following items to avoid interference of electromagnetism to unit and even failure of it.

1. To ensure normal communication of the unit, signal line and wiring (communication) of wired controller should separate from power cord and indoor/outdoor connection lines. The min distance between them should be 20cm.
2. If the unit is installed at the place where there is interference of electromagnetism, signal line and wiring (communication) of wired controller must be shielding twisted pair lines.

V INSTRUCTION TO OPERATION

5.1 On/Off

Press **On/Off** button to turn on the unit.
Repress this button to turn off the unit.

Note: The state shown in Fig.5.1 indicates off-state of the unit after energization. The state shown in Fig.5.2 indicates on-state of the unit after energization.



Fig.5.1 Off-state of the unit



Fig.5.2 On-state of the unit

5.2 Mode Setting

Under on-state of the unit, press **Mode** button to switch the operation modes as the following sequence:

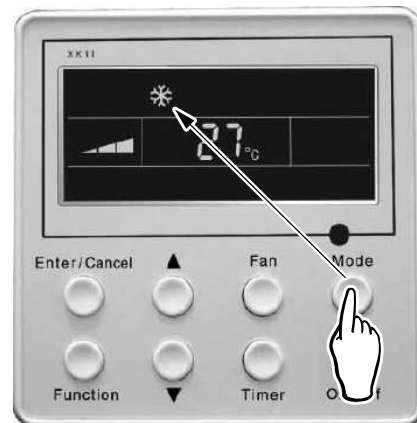
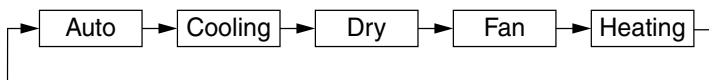

5.3 Temperature Setting

Press ▲ or ▼ button for increase or decrease of setting temperature under on-state of the unit. If press either of them continuously, temperature will be increased or decreased by 1°C every 0.5s. In Cooling, Dry, Fan and Heating mode, temperature setting range is 16 ~ 30°C. In Auto mode, the setting temperature is un-adjustable.

As shown in Fig.5.3



Fig.5.3

5.4 Fan Speed Setting

Press **Fan** button, fan speed of indoor unit will change as below:

As shown in Fig.5.4

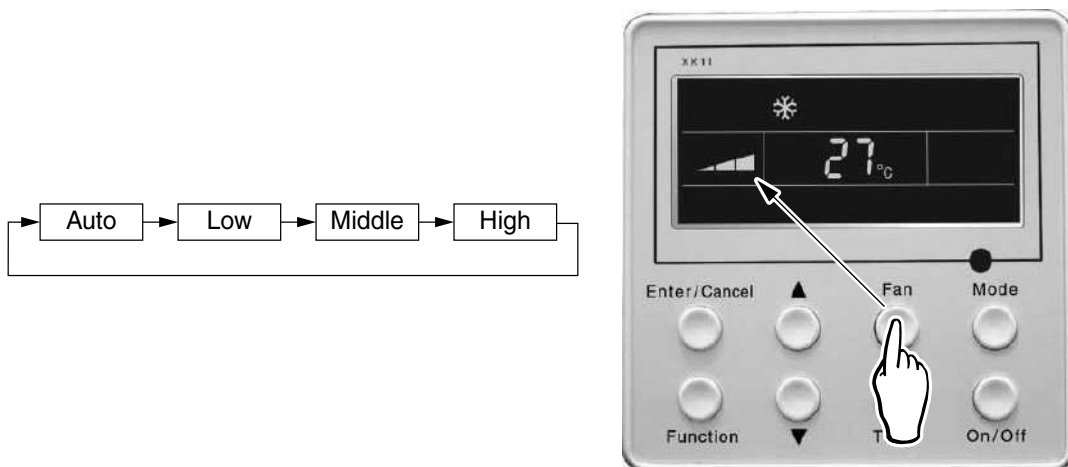

Fig.5.4

5.5 Swing Control Function*

Under on-state of unit, press **Function** button till the unit enters swing control function and then press **Enter/Cancel** button to turn on swing control function.

During swing function, press **Function** button till the unit enters swing control function and then press **Enter/Cancel** button to cancel swing control function.

Swing control function setting is shown in Fig.5.5

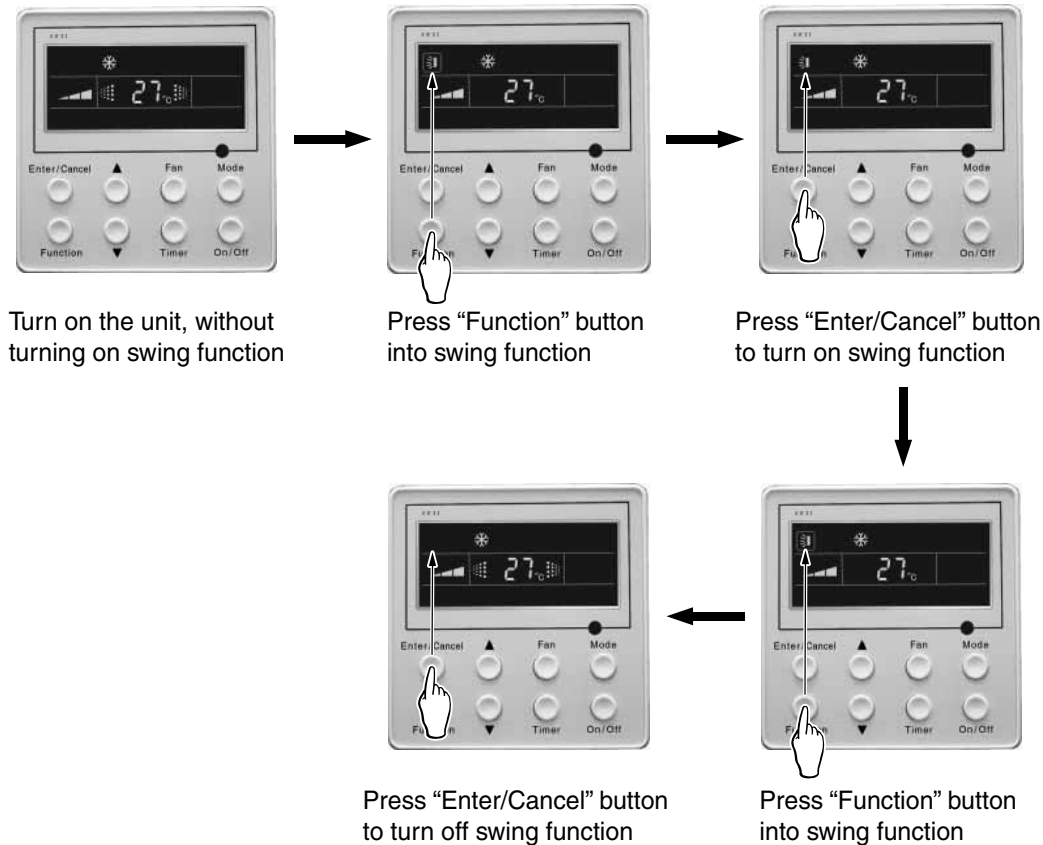

Fig.5.5

5.6 Timer Setting

Press **Timer** button to set timer off of the unit. Under off-state of the unit, press **Timer** button to set timer on of the unit in the same way.

Timer on setting: Under off-state of the unit without timer setting, if **Timer** button is pressed, LCD will display **xx. Hour, ON** blinking. In this case, press **▲** or **▼** button to adjust timer on and then press **Timer** to confirm. If **Mode** button is pressed before pressing **Timer** button to confirm, timer mode will be switched to timer off setting mode. In this case, LCD displays **xx. Hour, OFF** blinking. In this case, press **▲** or **▼** button to adjust timer off and then press **Timer** to confirm. When LCD displays **xx. Hour On Off**, **xx. Hour** means time of timer on, but time of timer off won't be displayed.

Timer off setting: Under on-state of the unit without timer setting, if **Timer** button is pressed, LCD will display **xx. Hour, OFF** blinking. In this case, press **▲** or **▼** button to adjust timer on and then press **Timer** to confirm. If **Mode** button is pressed before pressing **Timer** button to confirm, timer mode will be switched to timer on setting mode. In this case, LCD displays **xx. Hour, ON** blinking. In this case, press **▲** or **▼** button to adjust timer on and then press **Timer** button to confirm. When LCD displays **xx. Hour On Off**, **xx. Hour** means time of timer off, but time of timer on won't be displayed.

Cancel timer: After setting of timer, if **Timer** button is pressed, LCD won't display **xx. Hour** so that timer setting is canceled.

Timer off setting under on-state of the unit is shown as Fig.5.6

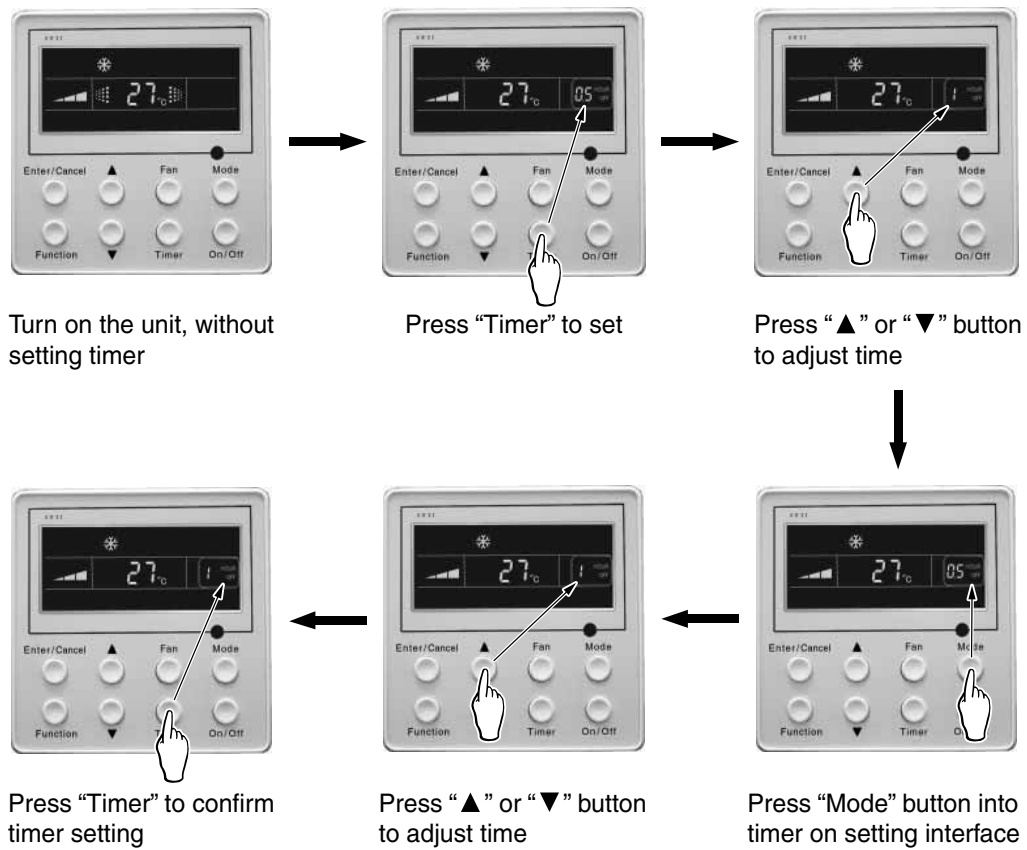

Fig.5.6 Timer setting under on-state of the unit

Timer range: 0.5-24hr. Every press of ▲ or ▼ button will make setting time increased or decreased by 0.5hr. If press either of them continuously, setting time will automatically increase/decrease by 0.5hr every 0.5s.

Note:

1. If both timer on and timer off are set in unit on-state, the wired controller only display time of timer off. If both of them are set in unit off-state, only time of timer on is displayed.
2. Timer on in on-state is timed from the time of unit off and timer off in unit off-state is timed from the time of unit on.

5.7 Air Exchange Setting*

Turn-on air exchange function:

Under on-state of the unit, press **Function** button into this function setting (Air mark blinks). AIR 1 displayed at the ambient temperature-displayed location (888) is defaulted (the last type of AIR will be displayed after adjustment). Press **▲** or **▼** button to adjust air exchange type. Press **Enter/Cancel** button to turn on/off air exchange function. After turning on this function, the air mark shows.

There are 10 types of air exchange, but only 1-2 types are for wireless remote control. Refer to the following details:

- 1 — The unit continuously runs for 60min, and fresh air valve opens for 6 min.
- 2 — The unit continuously runs for 60min, and fresh air valve opens for 12 min.
- 3 — The unit continuously runs for 60min, and fresh air valve opens for 18 min.
- 4 — The unit continuously runs for 60min, and fresh air valve opens for 24 min.
- 5 — The unit continuously runs for 60min, and fresh air valve opens for 30 min.
- 6 — The unit continuously runs for 60min, and fresh air valve opens for 36 min.
- 7 — The unit continuously runs for 60min, and fresh air valve opens for 42 min.
- 8 — The unit continuously runs for 60min, and fresh air valve opens for 48 min.
- 9 — The unit continuously runs for 60min, and fresh air valve opens for 54 min.
- 10 — The unit continuously runs for 60min, and fresh air valve always opens.

Turn-off air exchange function:

During air exchange function, press **Function** button into air exchange function. In this case, air mark is blinking, and then press **Enter/Cancel** button to turn off this function. Air mark will subsequently disappear.

Air exchange setting is shown as Fig.5.7:

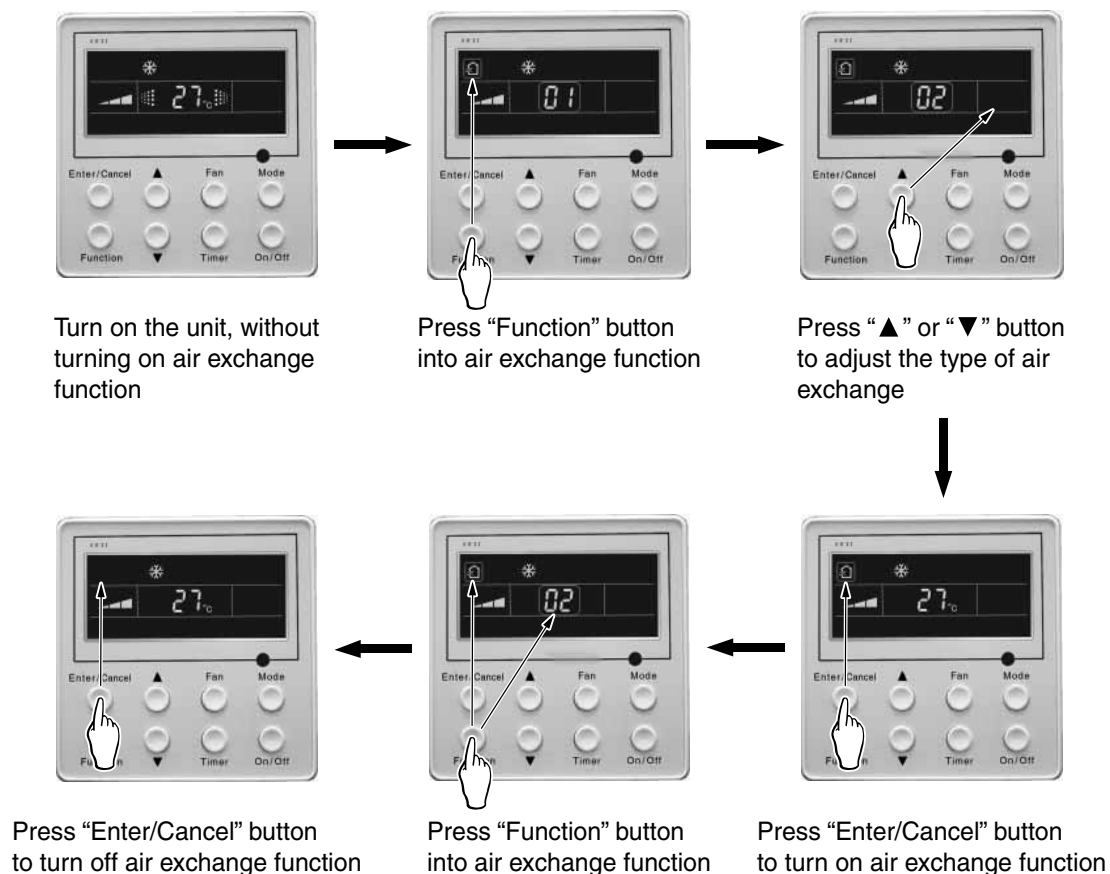

Fig.5.7 Air exchange device

Note: In air exchange mode, press "Function" button or there is no any operation within 5s after the last button operation, the system will quit from air exchange setting, and current setting data won't be memoried.

5.8 Sleep Setting

Sleep on: Press **Function** button under on-state of the unit into Sleep function and then press **Enter/Cancel** button to turn on sleeping function.

Sleep off: During sleep on state, press **Function** button into Sleep function and then press **Enter/Cancel** button to turn off this function.

Sleep setting is shown as Fig.5.8:

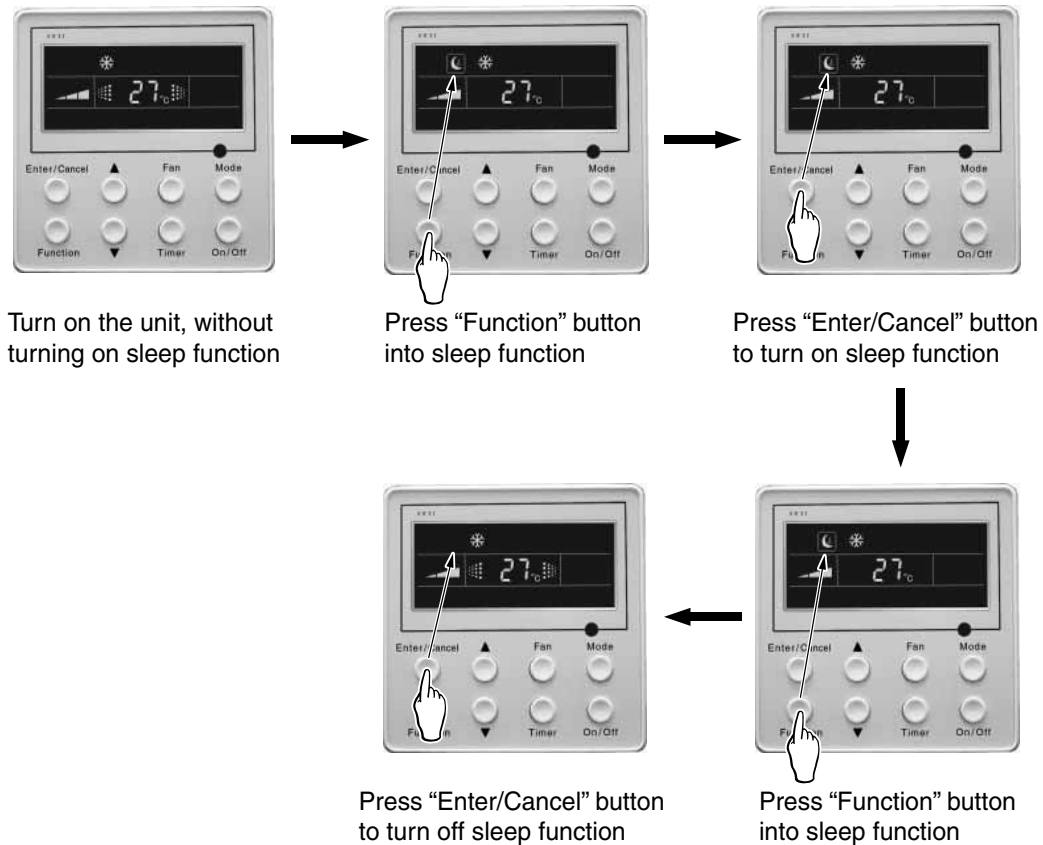

Fig.5.8 Sleep setting

Sleep setting is cleared after power failure and then power recovery. There is no sleep function in fan and auto mode.

Note: In cooling and dry mode, if the unit with sleep function has run for 1 hour, the preset temperature will be increased by 1°C and 1°C in another 1 hour. After that, the unit will run at this temperature. In heating mode, if the unit with sleep function has run for 1 hour, the preset temperature will be decreased by 1°C and 1°C in another 1 hour. After that, the unit will run at this temperature.

5.9 Turbo Function Setting

Turbo function: The unit at high fan speed can realize quick cooling or heating so that room temperature can quickly approach setting temperature.

In cooling or heating mode, press **Function** button till the unit enters turbo function and then press **Enter/Cancel** button to turn on turbo function.

During turbo function, press **Function** button till the unit enters turbo function and then press **Enter/Cancel** button to cancel turbo function.

Turbo function setting is shown in Fig.5.9:

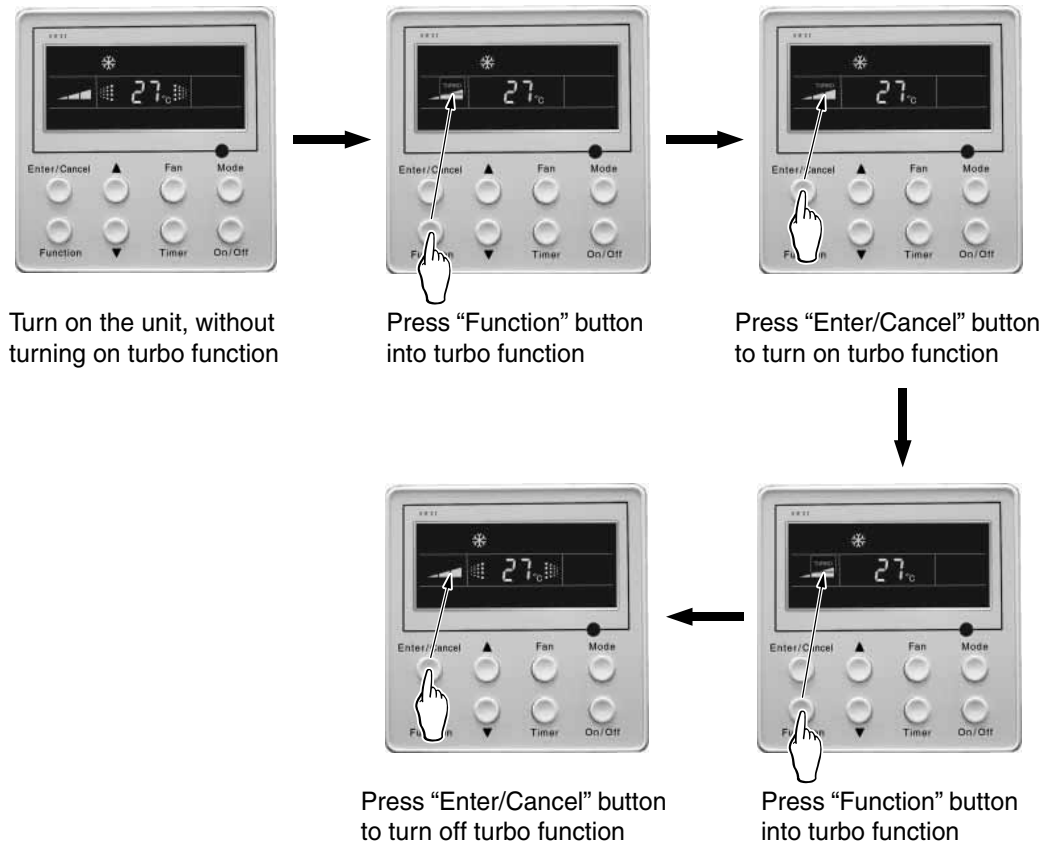

Fig.5.9 Turbo Function Setting

Note:

1. Turbo function will be turned off after power failure and then recovery. In dry, fan and auto mode, turbo function can not be set and TURBO mark won't be displayed.
2. Turbo function will be automatically canceled after setting of quiet function.

5.10 Save Function Setting

Energy Saving Function: Energy saving result that the air conditioner runs in smaller temperature range is realized by setting lower limited value of setting temperature in cooling or dry mode and upper limited value in heating mode.

Energy Saving Setting for Cooling

Under on-state and in cooling or dry mode of the unit, press **Function** button into energy saving function, **SAVE** blinking. Press **▲** or **▼** button to adjust lower limited value of setting temperature in cooling mode.

After that press **Enter/Cancel** button to turn on energy saving function for cooling.

Energy Saving Setting for Heating

Under on-state and in heating mode of the unit, press **Function** button into energy saving function, **SAVE** blinking. Press **Mode** button into energy saving function for heating and then press **▲** or **▼** button to adjust upper limited value of setting temperature in heating mode. Then, press **Enter/Cancel** button to turn on energy saving function for heating.

After energy saving function is turned on, press **Function** button into energy saving function and press **Enter/Cancel** button to cancel this function.

The energy saving setting is shown in the Fig.5.10.

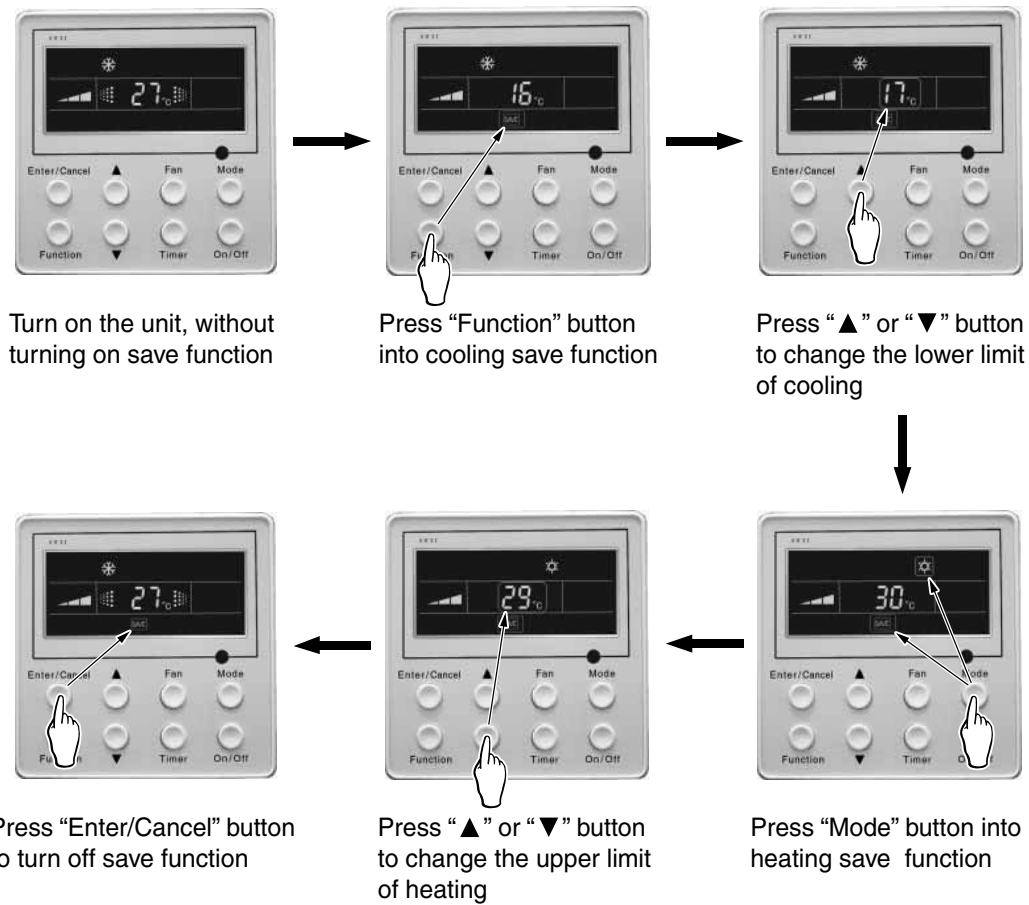

Fig.5.10 Energy Saving Setting

Note:

1. In auto running mode with save function on, the unit will forcibly quit auto running mode and change to current operation mode. After setting of SAVE, sleep function will be canceled.
2. In save mode, if **Function** button is pressed or there is not any operation within 5s after the last button operation, the system will quit from save function setting and current data won't be memorized.
3. After power failure and then recovery, save function setting will be memorized.
4. The lower limited value in cooling mode is 16°C and the upper limited value in heating mode is 30°C.
5. After save setting, if the setting temperature is out of the range in the mode, the limited value will prevail.

5.11 E-heater Setting*

E-heater: In the heating mode, E-heater is allowed to be turned on for improvement of efficiency.

If heating mode is turned on by button operation, auxiliary electric heating function will be automatically turned on.

Press **Function** button in heating mode into auxiliary electric heating function, **E-HEATER** blinking, and press **Enter/Cancel** button to turn on this function. In this case, **E-HEATER** will be displayed, which means E-heater is allowed to be turned on.

If auxiliary electric heating function is on, press **Function** button to confirm or press **Enter/Cancel** button to cancel. In this case, **E-HEATER** won't be displayed, which means E-heater is prohibited to be turned on.

The setting of this function is shown as Fig.5.11 below:

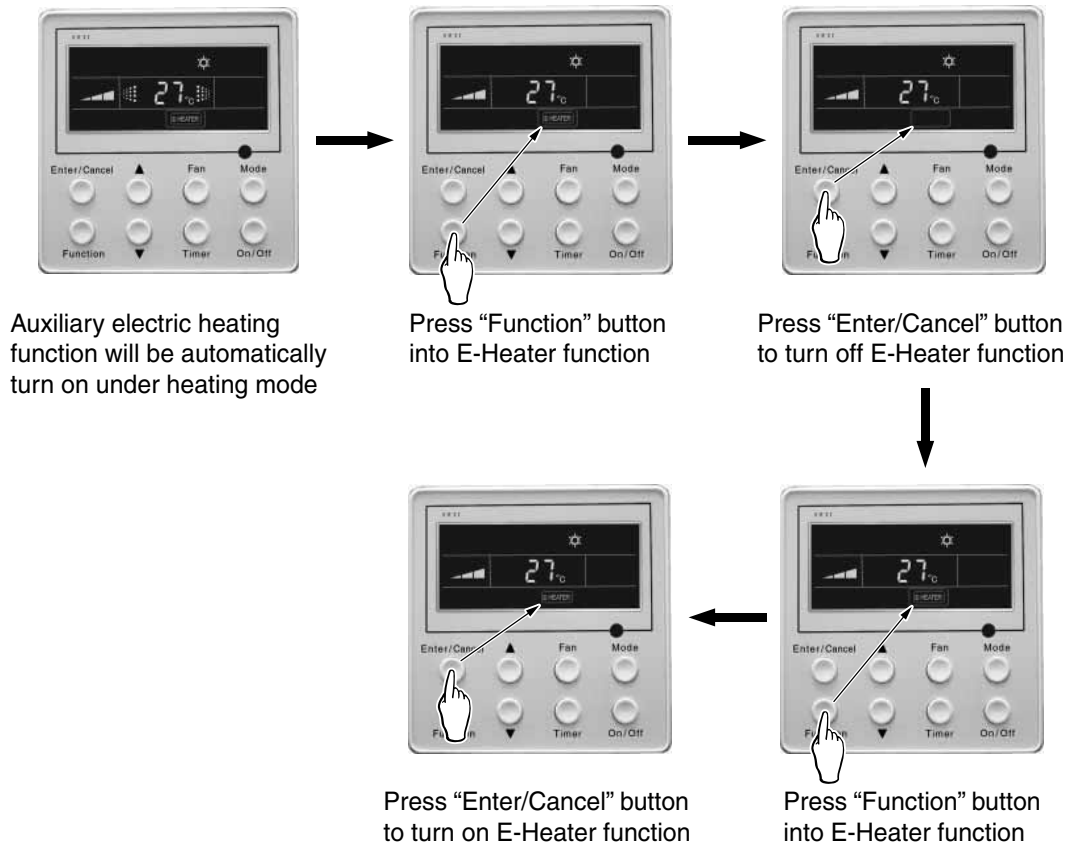

Fig.5.11 Auxiliary Electric Heating Function Setting

Note: E-heater can not be set in cooling, dry and fan mode, E-HEATER mark won't be displayed. The setting is shown in Fig.5.11.

5.12 Blow Function Setting

Blow function: After the unit is turned off, water in evaporator of indoor unit will be automatically evaporated to avoid mildew.

In cooling and dry mode, press **Function** button till the unit enters dry function, **BLOW** blinking, and then press **Enter/Cancel** button to turn on this function.

In blow mode, press **Function** button till the unit enters blow function and then press **Enter/Cancel** button to cancel this function.

Blow function setting is shown in Fig.5.12

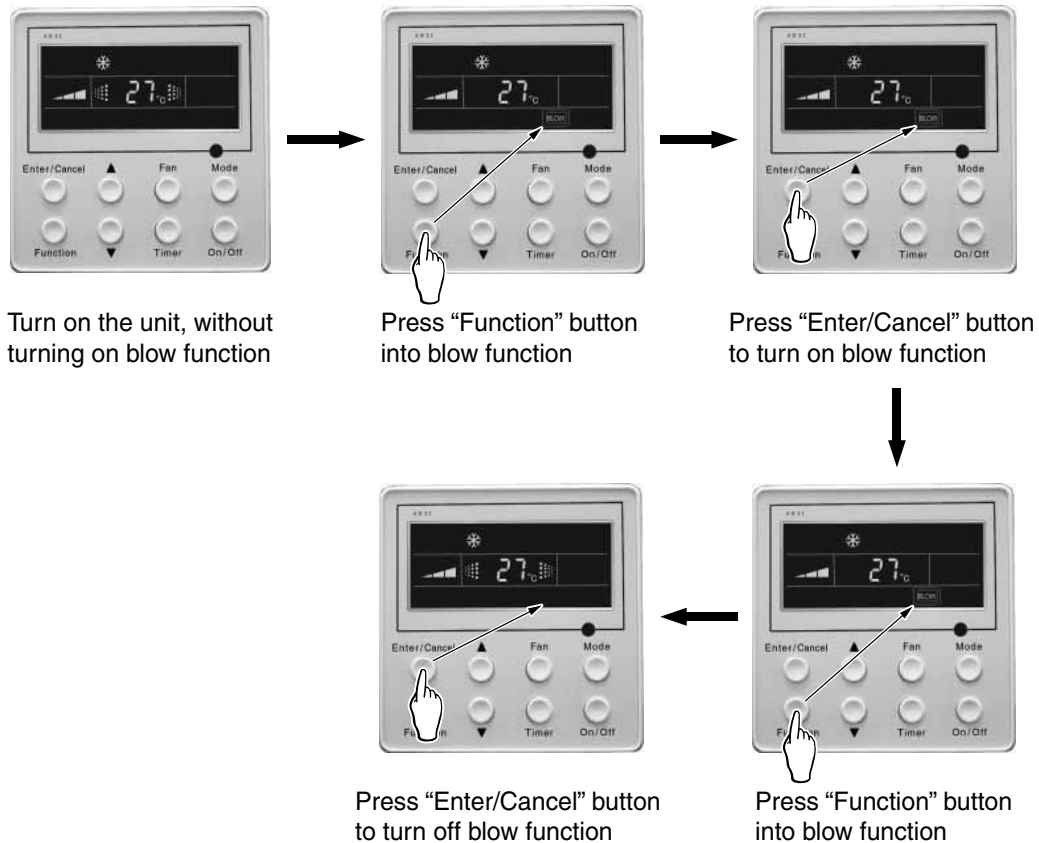

Fig.5.12 Blow function setting

Note:

1. After setting blow function, turn off the unit by pressing **On/Off** button or remote controller, indoor fan will run at low fan speed for 10 min. (**BLOW** shows). Meanwhile, if blow function is canceled indoor fan will be turned off directly.
2. There is no BLOW function in fan or heating mode.

5.13 Quiet Function Setting

Quiet function consists of two types: **QUIET** and **AUTO QUIET**.

Press **Function** button till the unit enters quiet function setting state, **QUIET** or **AUTO QUIET** mark blinks. In this case, press **▲** or **▼** button to switch between **QUIET** and **AUTO QUIET** and then press **Enter/Cancel** button to turn on this function.

In quiet mode, press **Function** button till the unit enters quiet function. In this case, **QUIET** or **AUTO QUIET** icon blinks and then press **Enter/Cancel** button to cancel this function.

Quiet function setting is shown in Fig.5.13

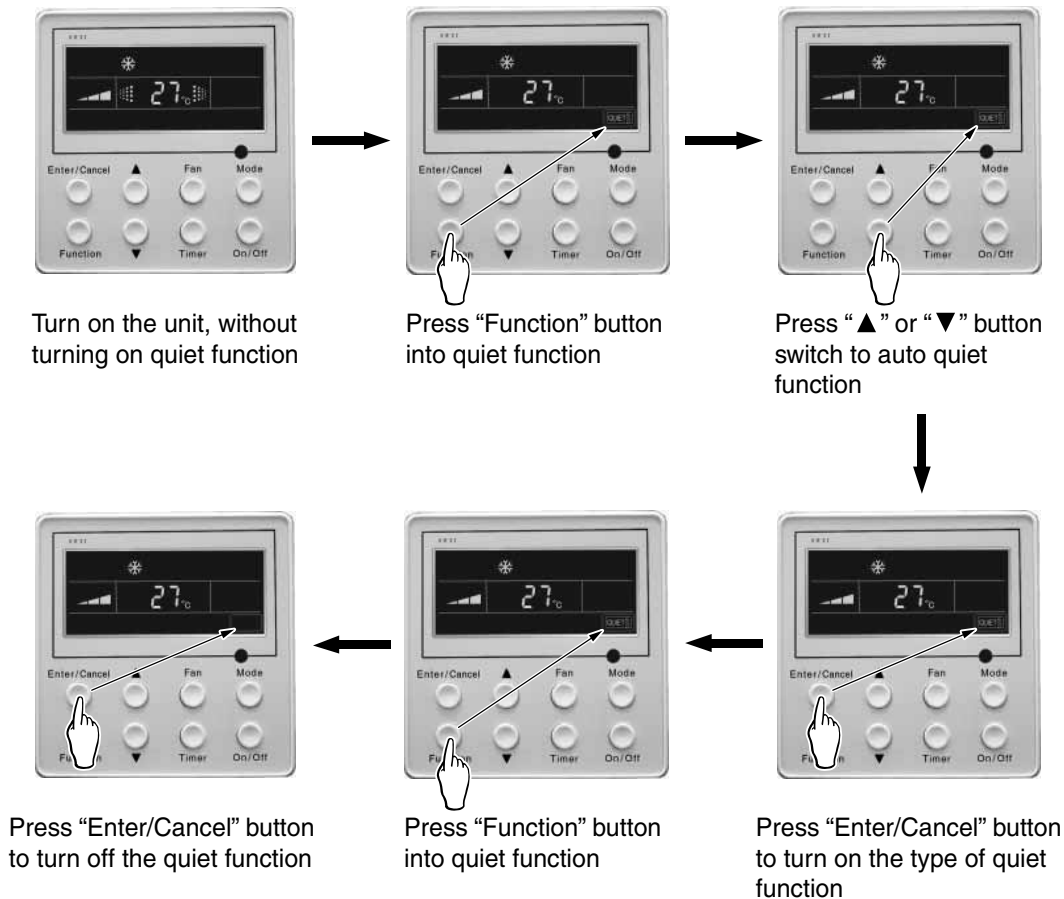

Fig.5.13 Quiet function setting

Note:

1. During quiet function, fan speed is un-adjustable.
2. When turning on auto quiet function, the unit will enter quiet running state according to temperature difference between room temperature and setting temperature. In this case, fan speed is adjustable. If temperature difference between room temperature and setting temperature $\geq 4^{\circ}\text{C}$, fan will keep its current speed; if $2^{\circ}\text{C} \leq$ temperature difference $\leq 3^{\circ}\text{C}$; fan speed will be reduce one grade, but if it is at min. grade, it is un-adjustable.; if temperature difference $\leq 1^{\circ}\text{C}$, fan speed will be at min.
3. In auto quiet mode, fan speed can not be raised but reduced. If high fan speed is manually adjusted, auto quiet mode will quit.
4. There is not auto quiet function in fan or dry mode. Quiet off is default after power failure and then power recovery.
5. If quite function is set, turbo function will be canceled.

5.14 Field Setting

Under off-state of the unit, press **Function** and **Timer** buttons continuously for 5s into debugging menu. Press **Mode** button to adjust the setting items and **▲** or **▼** button to set the actual value.

5.14.1 Ambient Temperature Sensor Setting

In field setting mode, press **Mode** button to adjust the temperature displayed location displaying 00, and press ▲ or ▼ button to adjust setting state at timer displayed location. There are 3 types for selection:

- (1) Indoor ambient temperature is that at return air inlet (01 is displayed at timer displayed location)
- (2) Indoor ambient temperature is that at the place of wired controller (02 is displayed at timer displayed location)
- (3) Return air inlet temperature sensor shall be selected for cooling, dry and fan modes and wired controller temperature sensor is selected for heating and auto modes (03 is displayed at timer displayed location).

5.14.2 Three Grades of Speed for Indoor Fan

In field setting mode, press **Mode** button to adjust the temperature displayed location displaying 01 and press ▲ or ▼ button to adjust setting state at timer displayed location. There are 2 types for selection:

- (1) 3 low grades (LCD displays 01)
- (2) 3 high grades (LCD displays 02)

Three low grades indicate high, medium and low grades and 3 high grades indicate super-high, high and medium grades.

Press **Enter/Cancel** button to save the setting and quit after setting. If there is not any operation within 20s after the system responds the latest button operation in this interface, the system will quit this menu and display normal off-state; meanwhile, current setting won't be saved.

5.15 Other Functions

5.15.1 Lock Function

Upon startup of the unit without malfunction or under off-state of the unit, press ▲ and ▼ buttons at the same time for 5s till the wired controller enters lock-state. In this case, LCD displays . After that, repress these two buttons at the same time for 5s to quit lock-state.

Under lock-state, any other buttons won't give any response to the press.

5.15.2 Memory Function

Memory switchover: Under off-state of the unit, press **Mode** and ▲ buttons at the same time for 5s to switch memory modes. During setting memory mode, **MEMORY** will be displayed. If this function is not set, the unit will be under off-state after power failure and then power recovery.

Memory recovery: If memory mode has been set for wired controller, the wired controller after power failure will resume its original running state upon power recovery.

Note:

1. It will take about 5s to save all the information. Please don't cut down the power after content changed in 5s, or it may be fail to save the content.

5.15.3 Selection of Centigrade and Fahrenheit

Under off-state of the unit, press **Mode** and ▼ at the same time for 5s, the LCD will switch between Centigrade and Fahrenheit.

VI ERROR DISPLAY

If there is error during running of the system, LCD will display error code at temperature–displayed location. Once many errors, error codes will be displayed circularly. If there are multiple circuit systems, the circuit number of failed system will be displayed before the colon (not for single system).

If error occurs, please turn off the unit and ask professionals for help.

As shown in Fig.6.1, it means high pressure protection of system 2 under unit on.



Fig.6.1

Error code meaning:

Error code	Error
E2	Indoor anti-freezing protection
E6	Communication error
E9	Water overflow protection
F0	Indoor unit ambient sensor error at air return opening
F1	Evaporator sensor error
F5	Ambient sensor error on Displayer (or LED board)

VII SETTING OF INDOOR ROOM SENSOR

7.1 Setting of Double Indoor Room Sensors

This series of ducted air-conditioning unit has two indoor room sensors. One is located at the air intake of the indoor unit and the other one is located inside the wired controller.

User can select one from the two indoor room sensors on the basis of the engineering requirement. (Refer to the section of wired controller instructions for detailed operation.)

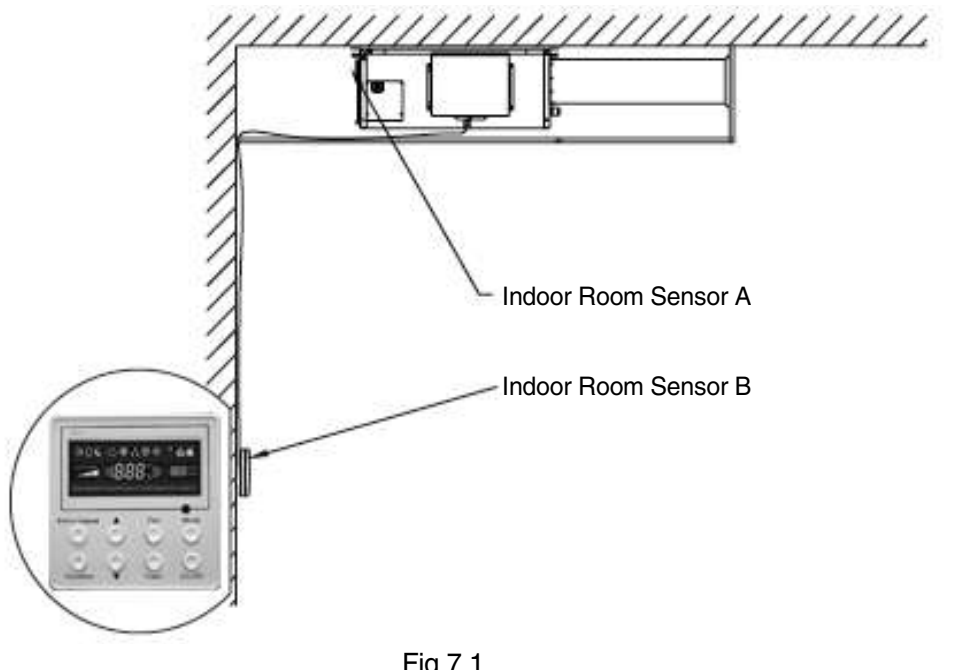

Fig.7.1

7.2 Fresh Air Control*

11-levels control can be realized for the amount of fresh air taken in. The function not only facilitates the health of users, but also controls the electricity consumption loss because of taking in fresh air. This kind of control can be carried out through the wired controller. The function can be set at any time, goes into effect at any time, and the operation is simple. (Refer to the section of wired controller instructions for detailed operation.)

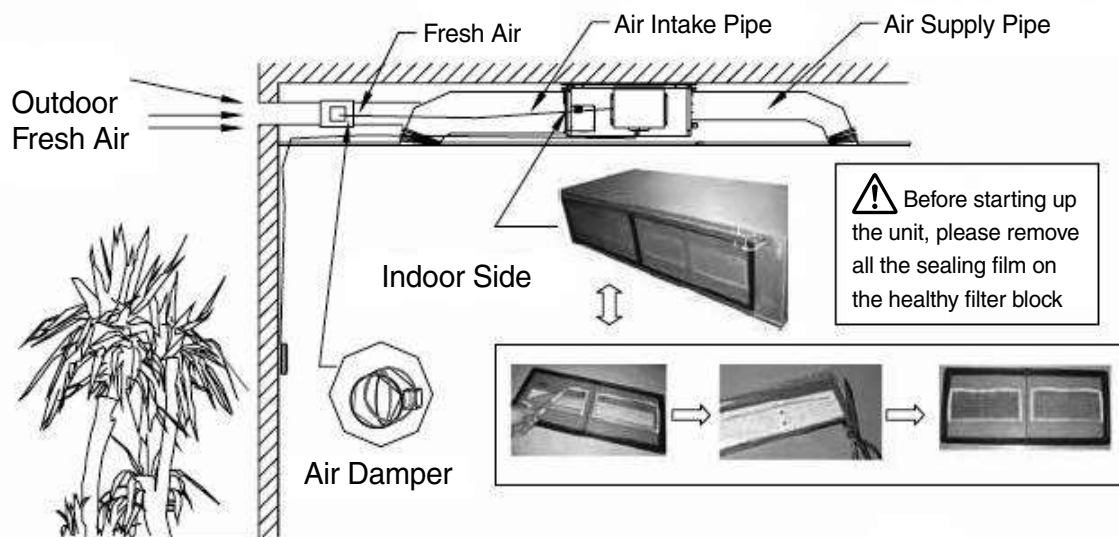

Fig.7.3

7.3 The head of delivery of the condensate drainage pump*

It can reach 1.1m, so that the engineering installation is very convenient and prompt.

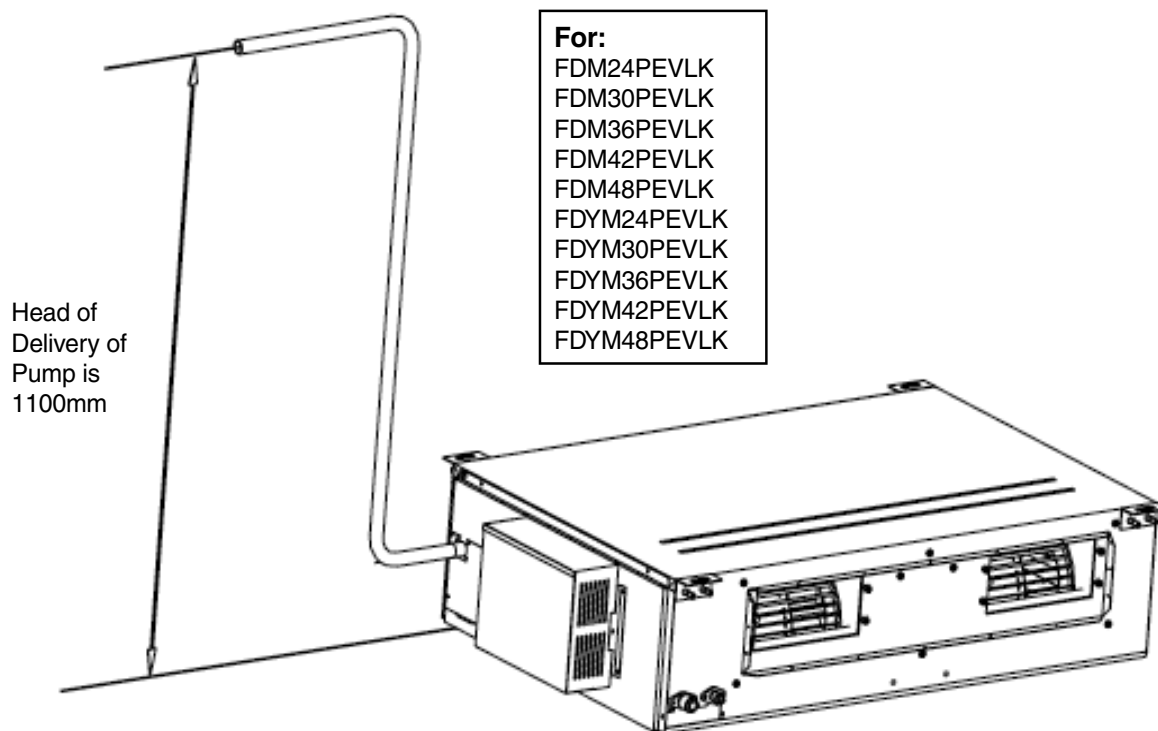

Fig.7.4

VIII DIMENSIONS OF INDOOR UNIT AND OUTDOOR UNIT

8.1 Dimensions of Indoor Unit

8.1.1 Dimensions of Indoor Unit

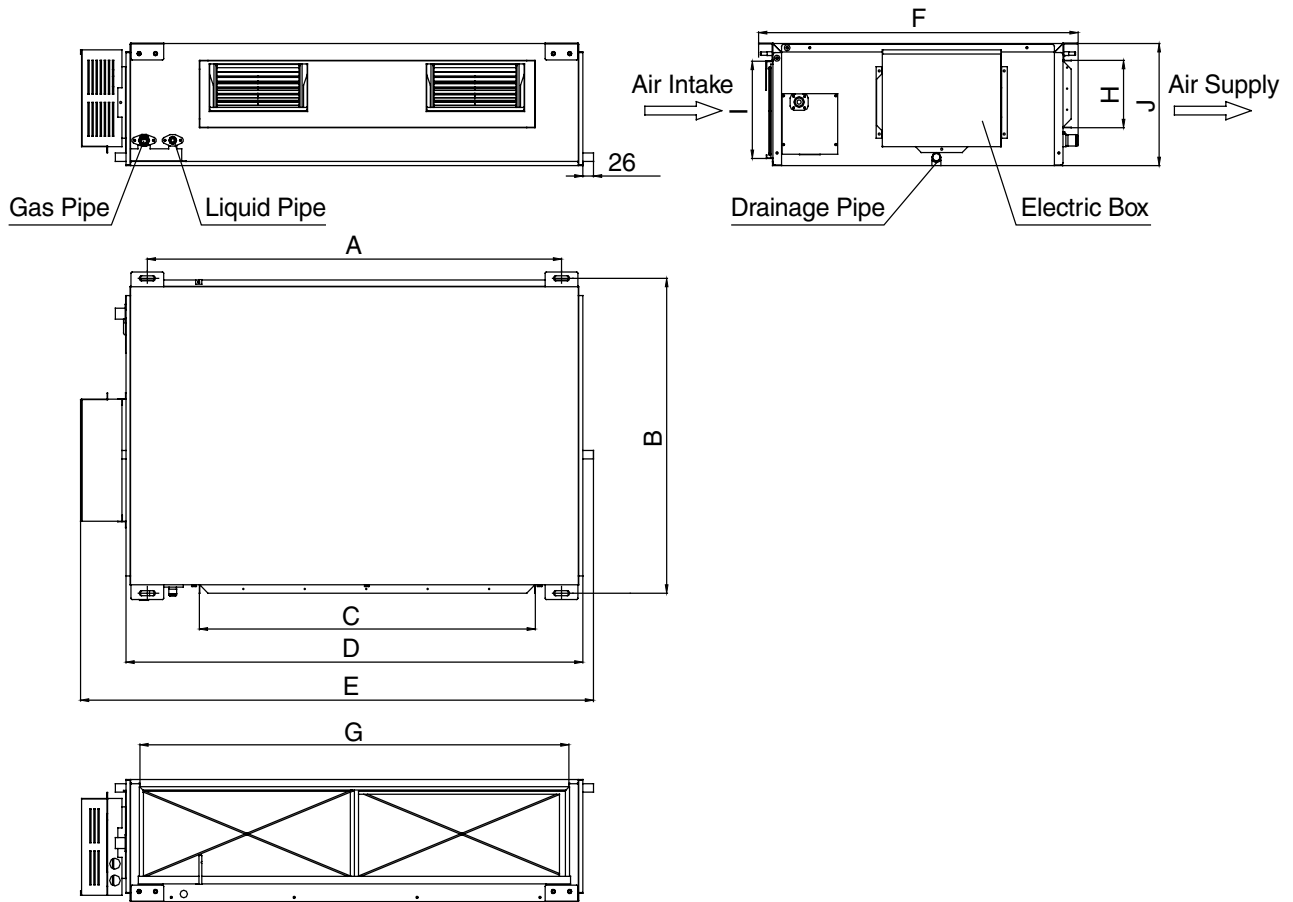

Fig.8.1

For

FDM24PEVLK	FDYM24PEVLK
FDM30PEVLK	FDYM30PEVLK
FDM36PEVLK	FDYM36PEVLK
FDM42PEVLK	FDYM42PEVLK
FDM48PEVLK	FDYM48PEVLK

Unit: mm

Item Model	A	B	C	D	E	F	G	H	I	J	the Refrige- rant Pipe (Liquid Pipe)	the Refrige- rant Pipe (Gas Pipe)	Drainage Pipe (Outer Diameter × Wall Thickness)
	FDM24PEVLK FDYM24PEVLK FDM30PEVLK FDYM30PEVLK	1101	515	820	1159	1270	530	1002	160	235	268	φ9.52	φ15.9
FDM36PEVLK FDYM36PEVLK	1011	748	820	1115	1226	775	979	160	231	290	φ12.7	φ19.05	φ20 × 1.2
FDM42PEVLK FDYM42PEVLK													
FDM48PEVLK FDYM48PEVLK													

8.1.2 Dimension Requirement of the Installation Space of Indoor Unit

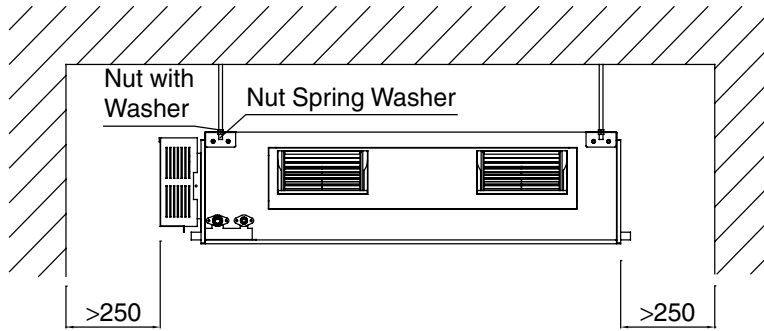

Fig.8.2

⚠ WARNING

The height of installation for the indoor unit should be above 2.5m.

8.2 Dimensions of Outdoor Unit

8.2.1 Dimensions of Outdoor Unit

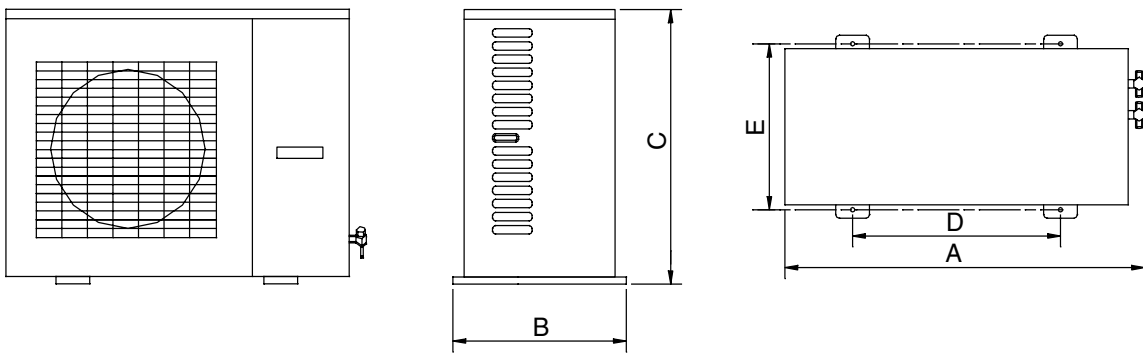

Fig.8.3

Unit : mm

Model	R24PEVLK RY24PEVLK	R30PEVLK R36PEVLK RY30PEVLK RY36PEVLK	R42PETLK R42PEYLK RY42PETLK RY42PEYLK	R48PETLK R48PEYLK RY48PETLK RY48PEYLK
A	1018	980	1107	1107
B	412	427	440	440
C	695	790	1100	1100
D	572	610	631	631
E	378	395	400	400

8.2.2 Dimension Requirement of the Installation Space of Outdoor Unit

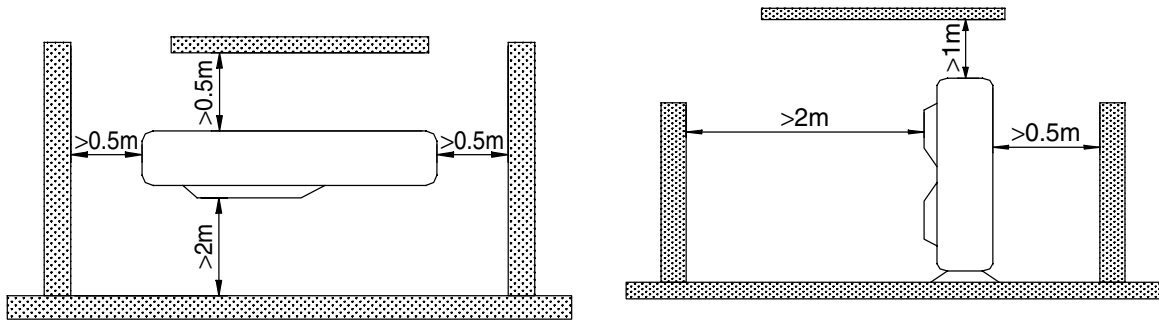

Fig.8.4

IX INSTALLATION INSTRUCTIONS

9.1 Precautions on Installation of Outdoor Unit

To ensure the unit in proper function, selection of installation location must be in accordance with following principles:

- (1) Outdoor unit shall be installed so that the air discharged by outdoor unit will not return and that sufficient space for repair shall be provided around the machine.
- (2) The installation site must have good ventilation, so that the outdoor unit can take in and exhaust enough air. Ensure that there is no obstacle for the air intake and exhaust of the outdoor unit. If there is any obstacle blocking the air intake or exhaust, remove it.
- (3) Place of installation shall be strong enough to support the weight of outdoor unit, and it shall be able to insulate noise and prevent vibration. Ensure that the wind and noise from the unit will not affect your neighbors.
- (4) Avoid direct sunshine over the unit. It is better to set up a sun shield as the protection.
- (5) Place of installation must be able to drain the rainwater and defrosting water.
- (6) Place of installation must ensure the machine will not be buried under snow or subject to the influence of rubbish or oil fog.
- (7) The installation site must be at a place where the air exhaust outlet does not face strong wind.

9.2 Precautions on Installation of Indoor Unit

9.2.1 Selection of Installation Site

- (1) Ensure the top hanging piece has strong strength to withstand the weight of the unit.
- (2) The drainage pipe has convenient flow of water.
- (3) There is no obstacle blocking the air intake and exhaust outlet, so as to ensure sound air circulation.
- (4) The installation spaces required by the drawing must be ensured, so as to provide enough space for the service and maintenance.
- (5) The installation site must be far away from heat source, leakage of inflammable gas or smoke.
- (6) The indoor unit is of ceiling mount (indoor unit is hidden inside the ceiling).
- (7) The indoor and outdoor units, the power cable and the connecting electrical lines must be at least 1 meter from any TV set or radio. This is to avoid image interference or noise of the TV set or radio. (Even if the distance is 1 meter, noise can also exist if there is strong electric wave.)

9.2.2 Installation of Indoor Unit

- (1) Insert a M10 expansion bolt into the hole. Drive a nail into the bolt. Refer to the profile dimensions drawing of the indoor unit for the distance between the holes. Refer to Fig. 9.1 for the installation of the expansion bolt.

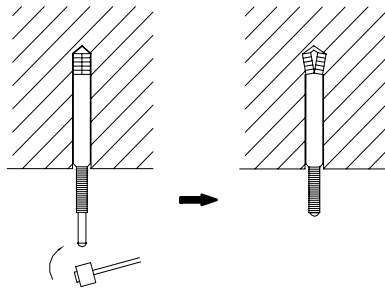

Fig.9.1

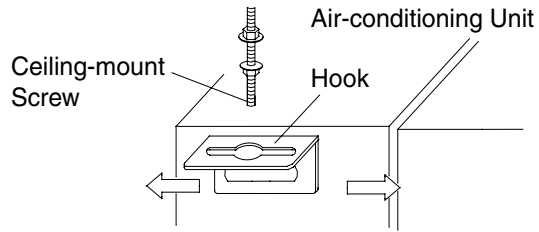

Fig.9.2

- (2) Install the hook onto the indoor unit as Fig. 9.2 shows.
- (3) Install the indoor unit at the ceiling as Fig. 9.3 shows.

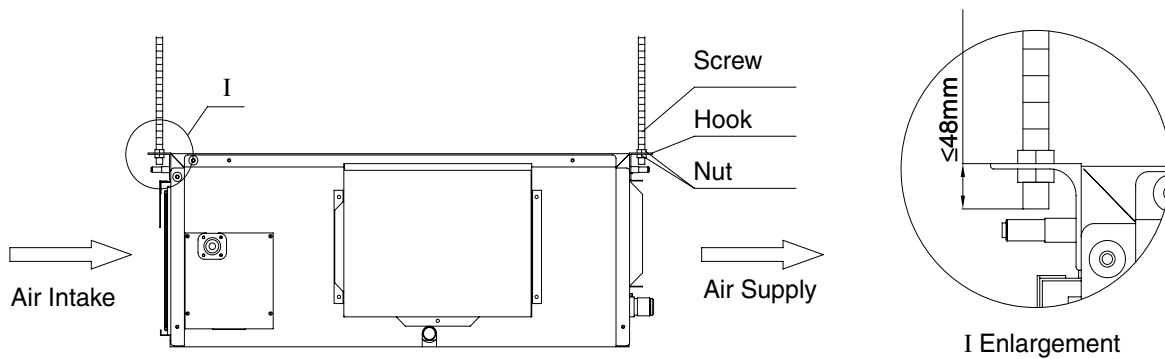

Fig.9.3

⚠ PRECAUTIONS

1. The preparation of all pipes (the refrigerant pipes and drainage pipes) and cables (connecting lines of wired controller, indoor unit and outdoor unit) must be ready before the installation, so as to achieve smooth installation.
2. Drill an opening on the ceiling. Maybe it is required to support the ceiling to ensure the evenness of it and avoid the vibration of it. Consult the user or a construction company for details.
3. In case the strength of ceiling is not enough, use angle iron sections to set up a beam support. Place the unit at the beam and fix it.

9.3 Level Check of the Indoor Unit

After the indoor unit is installed, it is required to check the level of the whole unit. The unit must be placed horizontally, but the condensate pipe shall be installed obliquely, so as to facilitate the drainage of condensate.

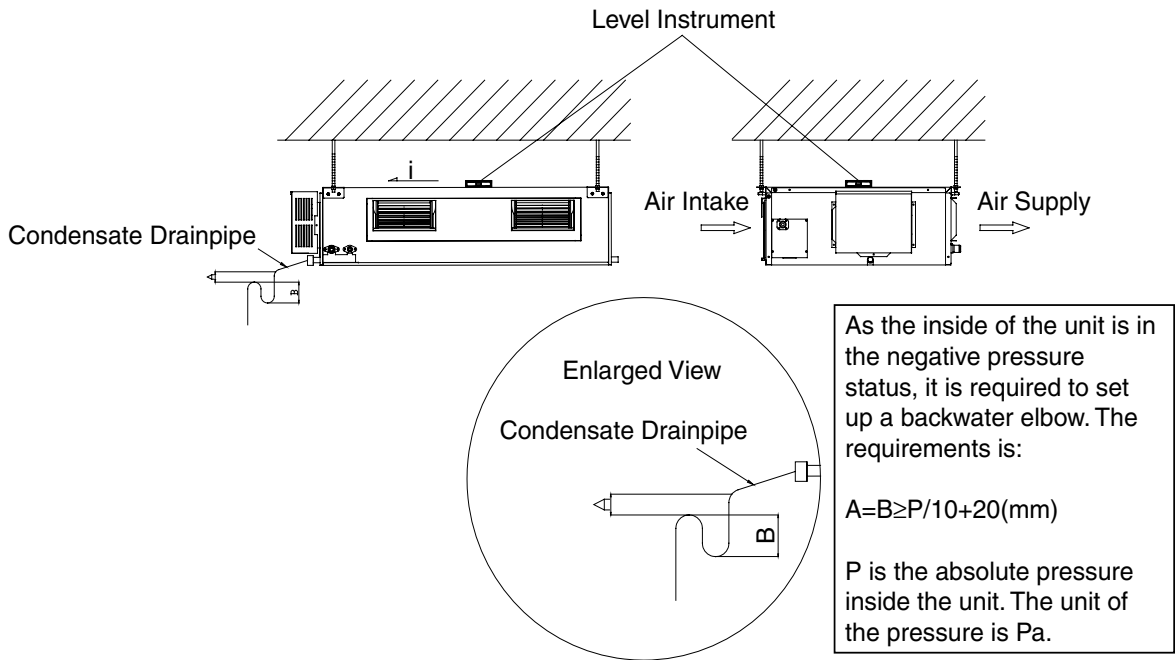

Fig.9.4

9.4 Installation of Rectangular Air Pipe

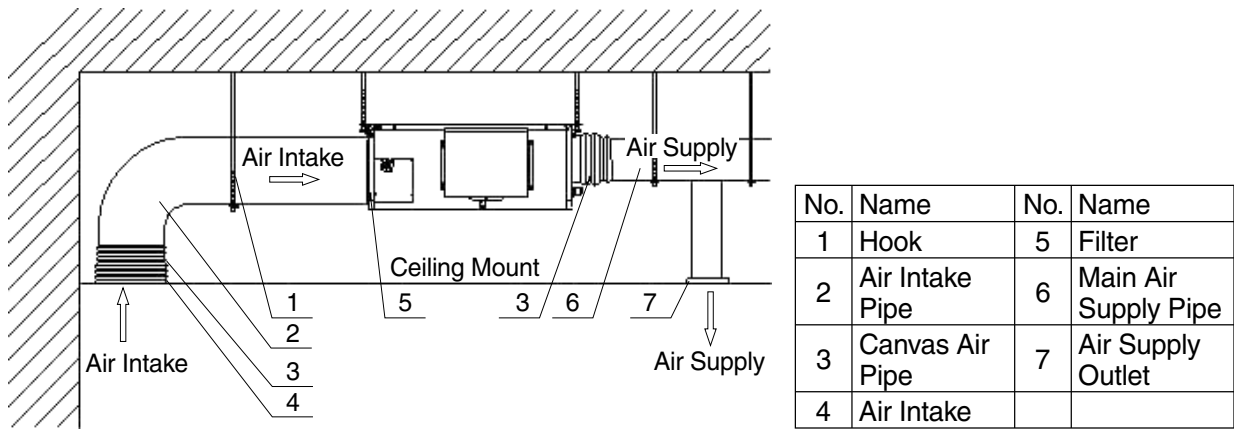

Fig.9.5

⚠ CAUTION

- The air supply pipe, the air intake pipe and the fresh air pipe must be covered with a layer of thermal insulation, so as to avoid thermal leakage and condensation. Firstly apply liquid nail on the pipes, then, attach the thermal insulation cotton with a layer of tinfoil. Use the liquid nail cover to fix it. Lastly use tinfoil adhesive tape to carefully seal the joints. Other good thermal insulation materials can also be used.
- The air supply pipes and the air intake pipes shall be fixed to the prefabricated boards of the ceiling by using iron supports. The joints of the pipes must be sealed by glue so as to avoid leakage.
- The design and installation of air pipes must be in conformity with the relevant state engineering criteria.
- The edge of the air intake pipe must be at least 150mm away from the wall. The air intake must be covered with filter.
- Silencing and shock absorption shall be considered in the design and installation of the air pipes. Additionally, the noise source must be far away from where people stay. The air intake shall not be located above the place where users stay (offices and rest places, etc.).

9.5 Installation of Drainage Pipeline

- (1) The drainage pipeline shall be installed with an inclining angel of $5 \sim 10^\circ$, so as to facilitate the drainage of condensate. The joints of the drainage pipeline must be covered by thermal insulation materials to avoid generation of exterior condensate. (As shown in Fig. 9.6)
- (2) A drainage outlet is located at both the left and right sides of the indoor unit. After selecting one condensate outlet, the other outlet shall be blocked by rubber plug. Bundle the blocked outlet with string to avoid leakage, and also use thermal insulation materials to wrap the blocked outlet.
- (3) When shipped out from factory, both the drainage outlets are blocked by rubber plugs.
- (4) When connecting the drainage pipeline with the unit, do not apply excessive force to the pipeline at the side of the unit. The fixing position of the pipeline shall be near the unit.
- (5) Purchase general-purpose hard PVC pipe locally to be used as the drainage pipeline. When carrying out connection, place the end of the PVC pipeline into the drainage hole. Use flexible drainage tube and tighten it with thread loop. Never use adhesive to connect the drainage hole and the flexible drainage tube.
- (6) When the laid drainage pipeline is used for multiple units, the common pipe shall be about 100mm lower than the drainage outlet of each set of unit. A pipe with thicker wall shall be used for such purpose.

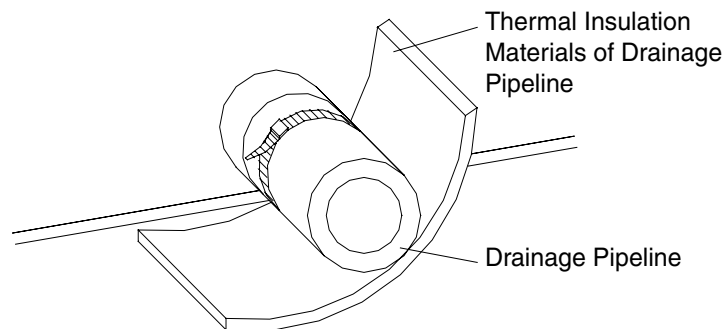

Fig.9. 6 Thermal Insulation of Drainage Pipeline

CAUTION

The joint of drainage pipeline must not have leakage.

9.6 Testing of Drainage System

- (1) After the electrical installation is completed, carry out the testing of the drainage system.
- (2) During the test, check if the water correctly flows through the pipelines. Carefully observe the joints to ensure that there is no leakage. If the unit is to be installed in a new house, carry out testing before decorating the ceiling.

9.7 Selection of the Refrigerant Pipe

Item Model	Size of the Refrigerant Pipe (inch)		Max. Pipe Length (m)	Max. Height Difference between Indoor Unit and Outdoor Unit (m)	Amount of Additional Refrigerant to be Filled (For Extra Length of Pipe)
	Gas Pipe	Liquid Pipe			
R24PEVLK+FDM24PEVLK RY24PEVLK+FDYM24PEVLK	5/8	3/8	30	15	60g/m
R30PEVLK+FDM30PEVLK RY30PEVLK+FDYM30PEVLK					
R36PEVLK+ FDM36PEVLK RY36PEVLK+ FDYM36PEVLK	3/4	1/2	50	30	120g/m
R42PETLK+ FDM42PEVLK R42PEYLK+ FDM42PEVLK RY42PETLK+ FDYM42PEVLK RY42PEYLK+ FDYM42PEVLK					
R48PETLK+ FDM48PEVLK R48PEYLK+ FDM48PEVLK RY48PETLK+ FDYM48PEVLK RY48PEYLK+ FDYM48PEVLK					

Note:

1. The standard pipe length is 5m. When the length (L) of the refrigerant pipe is less than or equals 5m, there is no need to add refrigerant. If the pipe is longer than 5m, it is required to add refrigerant. In the above table, the amounts of refrigerant to be added for the models are listed for each additional meter of pipe length.
2. The pipe thickness shall be 0.5-1.0 mm and the pipe thickness shall be able to withstand the pressure of 6.0 MPa.
3. The longer the refrigerant pipe, the lower the cooling effect and the heating effect.

9.8 Connection of the Refrigerant Pipe.

9.8.1 Installation Sketch of Throttle Valve

1. Structure of throttle valve

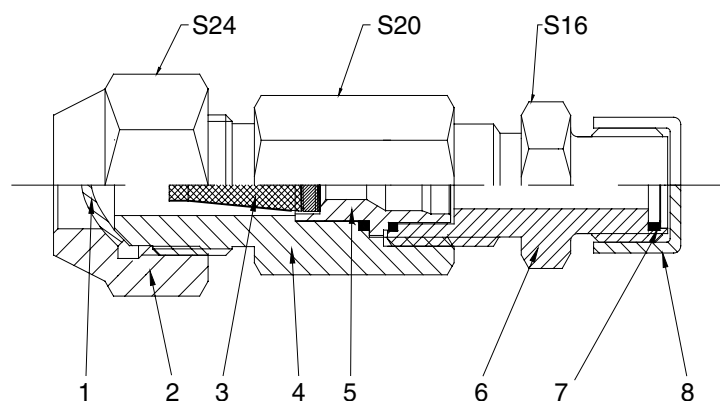

Fig.9.7 Structure of throttle valve

No.	Names	No.	Names
1	1/2 Copper seal cap	5	Valve base A
2	Coupling nut	6	Joint
3	Filter (60 mesh)	7	Seal gasket
4	Joint	8	Seal cap

2. During connection, remove the plastic seal cap at one end of the throttle valve (Part 8 in the above Fig.9.7)
3. Remove the end cap of liquid pipe joint (Note: Flange is equipped with the liquid pipe joint of ducted type unit)

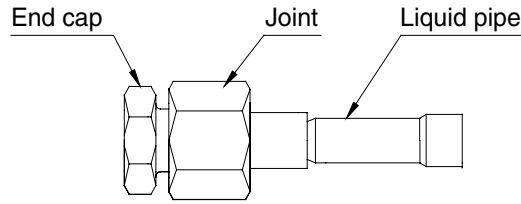

Fig.9.8

4. Confirm the specification of cooling/heating throttle orifice according to model of the unit (marked on the unit).

Model of Unit	Cooling Throttle Orifice	Heating Throttle Orifice
FDM24PEVLK FDYM24PEVLK	56#	47#
FDM30PEVLK FDYM30PEVLK	65#	60#
FDM36PEVLK FDYM36PEVLK	69#	58#
FDM42PEVLK FDYM42PEVLK	81#	65#
FDM48PEVLK FDYM48PEVLK	83#	76#

5. Installation of cooling throttle orifice
Put the cooling throttle orifice confirmed according to above table onto the valve base of liquid pipe joint.

Notice! Pay attention to specification and installation direction of throttle orifice.

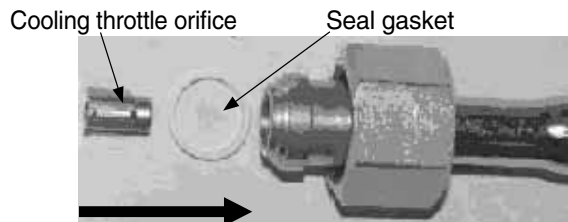

Fig.9.9

6. Installation of heating throttle orifice
Put the heating throttle orifice confirmed according to the above table onto the valve base A of throttle orifice.

Notice! Pay attention to specification and installation direction of throttle orifice.

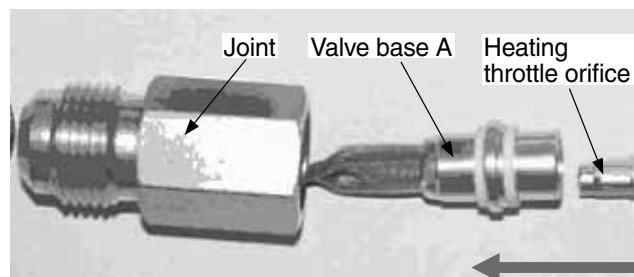

Fig.9.10

7. Installation sequence of throttle valve
The installation is shown in Fig.9.11:

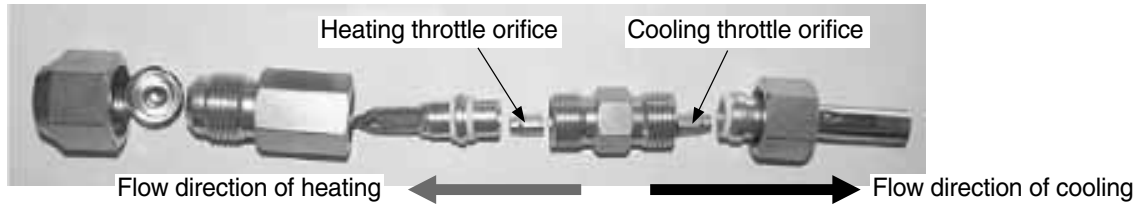

Fig.9.11

CAUTION

Notice! In order to ensure normal operation of the unit, never inversely install the cooling throttle orifice and heating throttle orifice.

Install the throttle valve and throttle orifice according to the above sequence. Meanwhile, the seal gaskets shall be installed properly at joints to prevent leakage.

The following table describes the torques for throttle valve.

Model	Torque moment
FDM24PEVLK FDYM24PEVLK	20±5 (N·m)
FDM30PEVLK FDYM30PEVLK	20±5 (N·m)
FDM36PEVLK FDYM36PEVLK	20±5 (N·m)
FDM42PEVLK FDYM42PEVLK	20±5 (N·m)
FDM48PEVLK FDYM48PEVLK	20±5 (N·m)

8. The refrigerant pipe and joint of throttle valve
After connection of throttle orifice, throttle valve and liquid pipe joint, connect the refrigerant pipe directly with joint of throttle valve.

9.8.2 Connection of the Refrigerant Pipe

1. Align the flared end of the copper pipe with the center of the thread joint. Manually tighten the flared end nut.
2. Use torque spanner to tighten the flared end nut until the spanner clatters (Fig. 9.12).

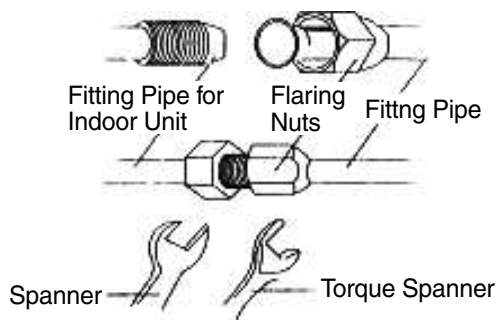

Fig.9.12

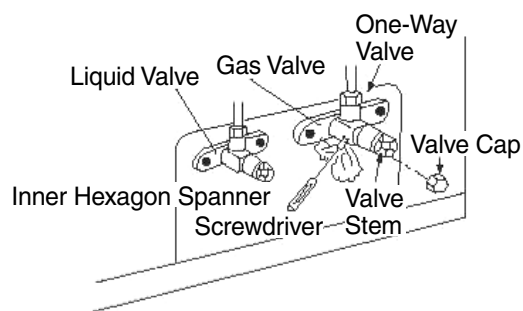

Fig.9.13

The following table describes the torques for tightening nuts of different pipe diameters.

Pipe Diameter	Tightening Torque
φ6.34mm	15-30 (N·m)
φ9.52mm	35-40 (N·m)
φ15.88mm	60-65 (N·m)
φ12.7mm	45-50 (N·m)
φ19.05mm	70-75 (N·m)
φ22.05mm	80-85 (N·m)

3. The bending angle of the fitting pipe shall not be too small, otherwise the pipe may break. Please use a bender when bending the fitting pipes.
4. Use sponge to wrap the refrigerant pipe and joint without thermal insulation, and use plastic tape to bundle the sponge.
5. Remove the caps of the liquid valve and the gas valve.
6. Use an inner hexagon spanner to loosen off the spool of the liquid valve for 1/4 circle. At the same time, use a screwdriver to lift the spool. Then there is discharge of gas.
7. Refrigerant gas shall come out in 15 seconds. Then, close the one way valve immediately and tighten the bonnet.
8. Fully open the spools of the liquid valve and the gas valve (refer to Fig. 9.13).
9. Tighten the caps of the valves. Then use soap water or leakage detector to check if there is leakage at the position where the indoor unit or the outdoor unit is connected with the refrigerant pipes.
10. If possible, use a vacuum pump to release air out of the valve. Refer to Fig. 9.14.

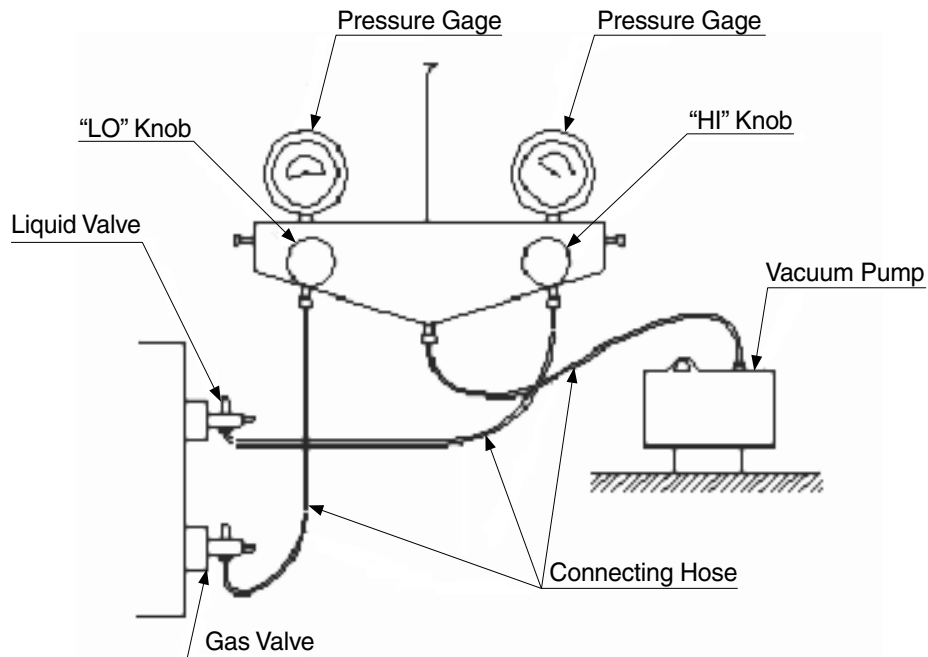

Fig.9.14

CAUTION

1. When connecting the indoor unit with the refrigerant pipe, do not pull the big and small joints of the indoor unit forcefully, so as to prevent the capillary of the indoor unit and other pipes from breaking and leaking.
2. The refrigerant pipe shall be supported by proper bracket. The weight of the pipe shall not be withstood by the unit.

9.9 Installation of Protective Layer of the Refrigerant Pipe

1. To avoid generation of condensate on the refrigerant pipe and leakage, the big pipe and the small pipe of the refrigerant pipe must be covered by thermal insulation materials, be bundled by adhesive tape, and be isolated from air.
2. The joint connecting to the indoor unit must be wrapped by thermal insulation material. There shall be no gap between the refrigerant pipe joint and the wall of the indoor unit. Refer to Fig. 9.15.

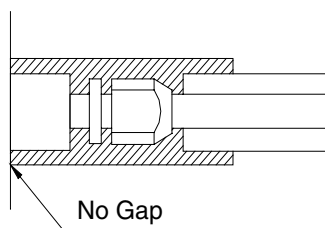

Fig.9.15

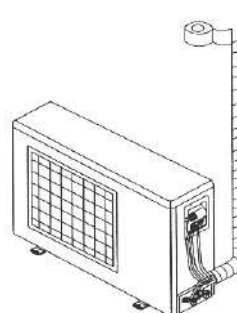

Fig.9.16

CAUTION

After the pipes are wrapped by protective materials, never bend the pipes to form very small angle, otherwise the pipes may crack or break.

3. Use adhesive tape to wrap the pipes:

- (1) Use adhesive tape to bundle the refrigerant pipe and the cables together. To prevent condensate from overflowing out from the drainage pipe, separate the drainage pipe from the refrigerant pipe and the cables.
- (2) Use thermal insulation tape to wrap the pipes from the bottom of the outdoor unit until the upper end of the pipe where the pipe enters the wall. When wrapping thermal insulation tape, the later circle of tape must cover half of the front circle of tape (Refer to Fig. 9.16).
- (3) Wrapped pipe must be fixed to wall using pipe clamps.

—  **CAUTION** —

- (1) Do not wrap the protective tape too tight, and otherwise the efficiency of thermal insulation may be decreased. Ensure that the condensate drainage flexible tube is separated from the bundled pipes.
- (2) After the protective work is completed and the pipes are wrapped, use seal material to block the hole in the wall, so as to prevent rain and wind from entering the room.

9.10 Position and Method of Installing wired controller

1. One end of the control wire of the wired controller is connected with electric box mainboard of indoor unit inside, it should be tightened by wire clamp, the other end should be connected with the wired controller. The special control wire used for the indoor unit and wired controller is 8 meters.
2. The material adopted for the control wire should be metallic. The wired controller could not be disassembled and the control wire used for the wired controller should not be changed by users. The installation and maintenance should be carried out by the professional personnel.
3. First, select an installation position. Leave a recess or an embedded wire hole to bury the control wire according to the size of the control wire of the wired controller.
4. If the control wire between the wired controller (85×85×16) and the indoor unit is surface-mounted, use 1# metallic pipe and make matching recess in the wall (refer to Fig. 9.17). If concealed installation is adopted, mount as Fig. 9.18.
5. No matter surface mounting or concealed mounting is selected, it is required to drill 2 holes (in the same level) of which the distance shall be the same as the distance (60mm) of installation holes in the bottom plate of the wired controller. Then insert a wood plug into each hole. Fix the bottom plate of the wired controller to the wall according to The two holes. Plug the control wire onto the wired controller. Then, install the panel of the wired controller (Refer to Fig. 4. 1).

—  **CAUTION** —

During the installation of the bottom plate of the wired controller, pay attention to the direction of the bottom plate. The plate's side with two notches must be at the lower position, otherwise the panel of the wired controller cannot be correctly installed.

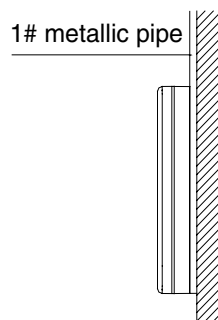

Fig.9.17 Surface Mounting of Cable

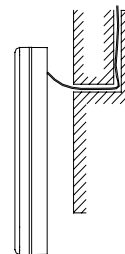

Fig.9.18 Concealed mounting of Cable

—  **CAUTION** —

1. The communication distance between the main board and the wired controller can be as far as 20m (The standard distance is 8m).
2. The wired controller shall not be installed in a place where there is water drop or large amount of water vapor.

9.11 Electric Installation

CAUTION

Before installing the electrical equipment, please pay attention to the following matters which have been specially pointed out by our designers:

1. Check if the power supply conforms to the rated power supply specified on the nameplate.
2. The capacity of the power supply must be large enough.
3. The cables must be installed by professional personnel.

An electricity leakage protection switch and an air switch with gap between electrode heads larger than 3mm shall be installed in the fixed line.

1. Connection of single wire
 - (1) Use wire stripper to strip the insulation layer (25mm long) from the end of the single wire.
 - (2) Remove the screw at the terminal board of the air-conditioning unit.
 - (3) Use pliers to bend the end of the single wire so that a loop matching the screw size is formed.
 - (4) Put the screw through the loop of the single wire and fix the loop at the terminal board.
 2. Connection of multiple twisted wires
 - (1) Use wire stripper to strip the insulation layer (10mm long) from the end of the multiple twisted wires.
 - (2) Remove the screw at the terminal board of the air-conditioning unit.
 - (3) Use crimping pliers to connect a terminal (matching the size of the screw) at the end of the multiple twisted wires.
 - (4) Put the screw through the terminal of the multiple twisted wires and fix the terminal at the terminal board.
-

WARNING

If the power supply flexible line or the signal cable of the equipment is damaged, use only special flexible line to replace it.

1. Before connecting cables, read the voltages of the relevant parts on the nameplate. Then carry out line connection according to the schematic diagram.
 2. The air-conditioning unit shall have special power supply cable which shall be equipped with electricity leakage switch and air switch, so as to deal with overload conditions.
 3. The air-conditioning unit must have grounding to avoid hazard owing to insulation failure.
 4. All fitting cables must use crimp terminals or single cable. If multiple twisted wires are connected to terminal board, arc may arise.
 5. All cable connections must conform to the schematic diagram of lines. Wrong connection may cause abnormal operation or damage of the air-conditioning unit.
 6. Do not let any cable contact the refrigerant pipe, the compressor and moving parts such as fan.
 7. Do not change the internal cable connections inside the air-conditioning unit. The manufacturer shall not be liable for any loss or abnormal operation arising from wrong cable connections.
-

Power Cable Connection:

1. Air-conditioning unit with single-phase power supply
 - (1) Remove the front panel of the outdoor unit.
 - (2) Attach rubber ring to the cable-cross hole of the outdoor unit.
 - (3) Pass the cable through rubber ring.
 - (4) Connect the power supply cable to the “L, N” terminals and the grounding screw.
 - (5) Use cable fastener to bundle and fix the cable.
2. Air-conditioning unit with 3-phase power supply
 - (1) Remove the front panel of the outdoor unit.
 - (2) Attach rubber ring to the cable-cross hole of the outdoor unit.
 - (3) Pass the cable through rubber ring.
 - (4) Connect the power cable to the terminal and earthing screws marked “L1, L2, L3 & N”.
 - (5) Use cable fastener to bundle and fix the cable.

⚠ CAUTION

Take great care when carrying out the following connections, so as to avoid malfunction of the air-conditioning unit because of electromagnetic interference.

- (1) The signal line of the wired controller must be separated from the power line and the connecting line between the indoor unit and the outdoor unit.
- (2) In case the unit is installed in a place vulnerable by electromagnetic interference, it is better to use shielded cable or double-twisted cable as the signal line of the wired controller.

Connection of Signal Cable of Wired Controller

1. Open the cover of the electric box of the indoor unit.
2. Pull the signal cable of the wired controller through the rubber ring.
3. Plug the signal line of the wired controller onto the 4-bit pin socket at the circuit board of the indoor unit.
4. Use cable fastener to bundle and fix the signal cable of the wired controller.

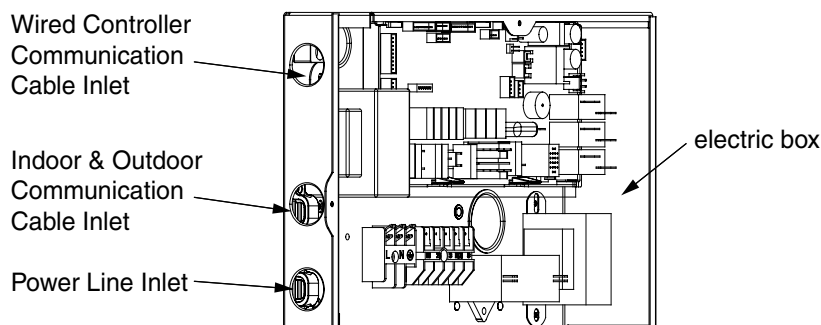

Mainboard Code Setting

Please find the corresponding mainboard according to the unit type and then check whether the mainboard code is correctly set.

The relation between mainboard type and unit type:

Duct type indoor unit mainboard: Z4G25

Code location and meaning:

Please find the corresponding mainboard according to the complete unit type and then check whether the mainboard code is correctly set. Cooling only unit is different with the cooling and heating unit about setting of the fourth code. When it is dialed to “4”, it means cooling and heating. When it is dialed to ON, it means cooling only. The third code remains in “3”. Please refer to the following figure for detailed coding.

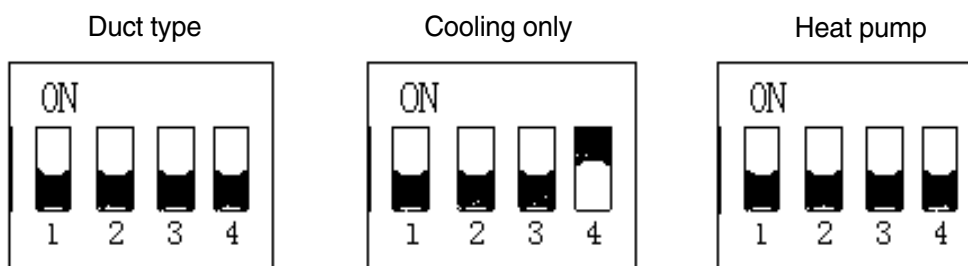

Remark: Main board for cooling only and heat pump is common use.

The defrosting setting

(1) The defrosting mode

After the compressor consecutively runs for “t” minutes, it will start defrosting if the sensor detects the temperature $\leq T1$ °C for consecutive 1 minute. It will stop defrosting when defrosting has run for 10 minutes or the sensor detects the temperature over “T2” °C

(2) The defrosting control

There are 8 defrosting modes corresponding to different DIP ways.

The “t”, “T1”, “T2”, “T” are defined as below:

t The defrosting temp sensor starts to detect after the compressor has been operating for t minutes accumulatively

T1 The defrosting board starts to work when the defrosting temp sensor has been in T1°C or under T1°C for 1 minute continuously

T2 The defrosting will stop after it goes on for 10 minutes continuously or the temp sensor detects the ambient temperature over T2°C

T Outdoor ambient temperature

DIP and corresponding temperature

Outdoor ambient temp. sensor	Outdoor ambient temp. sensor does not work					Outdoor ambient temp. sensor works						
	DIP	000	001	010	011	100	101		110		111	
T	-	-	-	-	-	-	≥ -3	< -3	≥ -3	< -3	≥ -3	< -3
t	44	44	60	90	30	30	60	44	90	90	120	
T1	-2	-5	0	0	0	-2	-10	-2	-10	-2	-15	
T2	15	20	20	20	20	20	15	20	15	20	15	

WARNING

The default setting of DIP switch included in the WZ14301-1 main board of outdoor unit:

DIP switch (SA1): Position 1,2,3 to “ON”.

In summary: In “heating” mode of A/C unit, after the compressor has been operating for t minutes continuously, the defrosting will starts if the defrosting temp sensor has been in T1°C or under T1°C for 1 minute continuously. At the same time, the 4-way valve is electrified, the fan motor of outdoor unit stops running.

The defrosting will stop after it goes on for 10 minutes continuously or the temp. sensor detects the ambient temperature over T2°C. At the same time, the 4-way valve is power cut, the fan motor of outdoor unit is electrified and the auxiliary electric heating device runs as per the setting of wired controller.

The defrosting stops immediately if the A/C is diverted to “COOLING” mode while the outdoor unit is defrosting.

Forced defrosting: When the forced defrosting button is pushed, the A/C will start to defrost promptly. At the same time, the 4-way valve is electrified, the fan motor of outdoor unit stops running and the auxiliary electric heating device is electrified. The defrosting will stop after it goes on for 10 minutes or the temp sensor detects the ambient temperature over T2. At the same time, the 4-way valve is power cut, the fan motor of outdoor unit is electrified and the auxiliary electric heating device runs as per the setting of wired controller.

DIP switch (SA1):

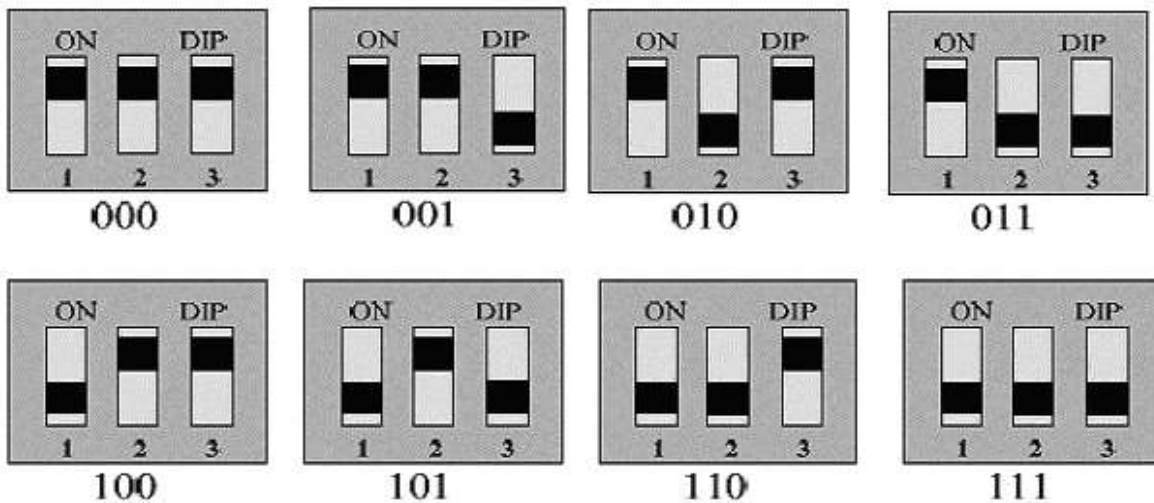

Note 1:

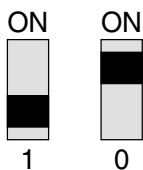

Note 2:

The Mainboard LED display instruction		
	LED1	LED2
Normal Operation	Blinks every 0.5s	Blinks every 0.5s
Defrosting	on	on
High pressure protection	Blinks every 0.5s	off
Low pressure protection	off	Blinks every 0.5s
Outdoor ambient Temp. Sensor Malfuction	off	on
Defrosting Temp. Sensor Malfuction	on	off

These two LEDs are for heat pump models only.

9.12 Cable Connecting Diagram

- The section area of cables selected by users must not be smaller than the specifications shown in the diagram. The signal wire between indoor and outdoor unit shall be installed in the shielded bushing, and the unshielded twisted pair cable (UTP) shall be used, the cross sectional area of the cables must be 1.0mm².

Schematic Diagram of Unit Line Connection:

R24PEVLK + FDM24PEVLK

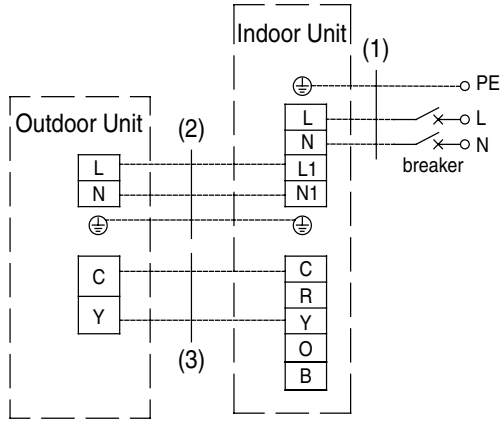

POWER 220V ~ 60HZ

- (1) Power Cord 3 × 4.0mm² (H07RN-F)
- (2) Power Cord 3 × 2.5mm² (H07RN-F)
- (3) Communication Cords 2 × 1.0mm² (H07RN-F)

Capability of Breaker: 25A

RY24PEVLK + FDYM24PEVLK

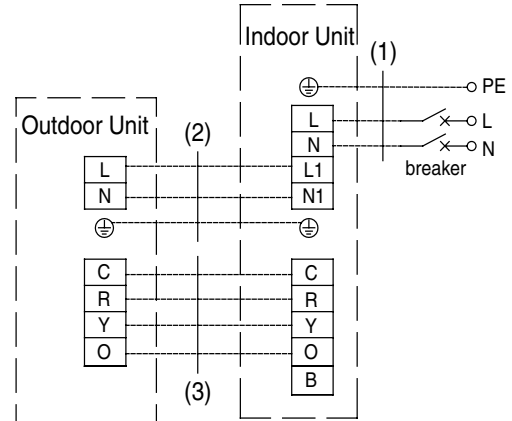

POWER 220V ~ 60HZ

- (1) Power Cord 3 × 4.0mm² (H07RN-F)
- (2) Power Cord 3 × 2.5mm² (H07RN-F)
- (3) Communication Cords 4 × 1.0mm² (H07RN-F)

Capability of Breaker: 25A

R30PEVLK + FDM30PEVLK

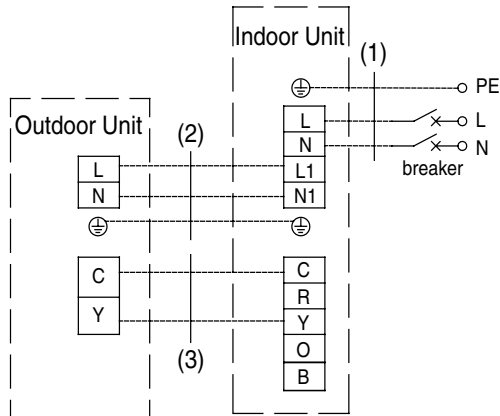

POWER 220V ~ 60HZ

- (1) Power Cord 3 × 6.0mm² (H07RN-F)
- (2) Power Cord 3 × 4.0mm² (H07RN-F)
- (3) Communication Cords 2 × 1.0mm² (H07RN-F)

Capability of Breaker: 32A

RY30PEVLK + FDYM30PEVLK

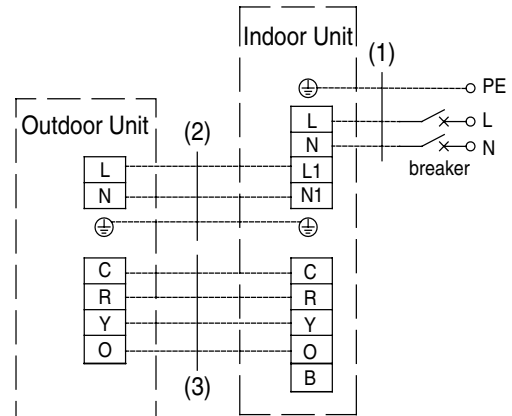

POWER 220V ~ 60HZ

- (1) Power Cord 3 × 6.0mm² (H07RN-F)
- (2) Power Cord 3 × 4.0mm² (H07RN-F)
- (3) Communication Cords 4 × 1.0mm² (H07RN-F)

Capability of Breaker: 32A

R36PEVLK + FDM36PEVLK

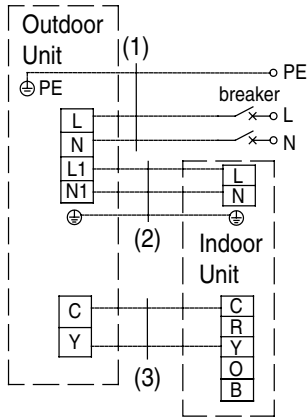

POWER 220V ~ 60HZ

- (1) Power Cord 3 × 6.0mm² (H07RN-F)
- (2) Power Cord 3 × 1.0mm² (H07RN-F)
- (3) Communication Cords 2 × 1.0mm² (H07RN-F)

Capability of Breaker: 32A

RY36PEVLK + FDYM36PEVLK

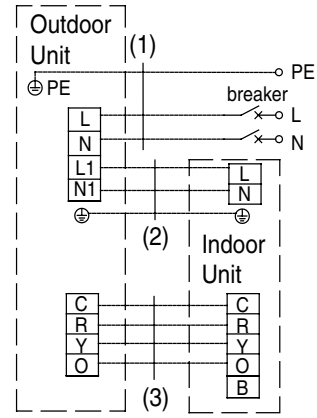

POWER 220V ~ 60HZ

- (1) Power Cord 3 × 6.0mm² (H07RN-F)
- (2) Power Cord 3 × 1.0mm² (H07RN-F)
- (3) Communication Cords 4 × 1.0mm² (H07RN-F)

Capability of Breaker: 32A

R42PETLK + FDM42PEVLK
R48PETLK + FDM48PEVLK

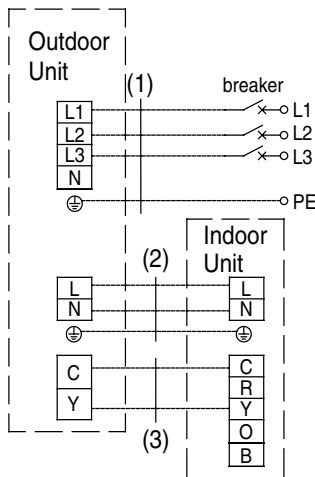

POWER 220V 3 ~ 60HZ

- (1) Power Cord 4 × 6.0mm² (H07RN-F)
- (2) Power Cord 3 × 1.0mm² (H07RN-F)
- (3) Communication Cords 2 × 1.0mm² (H07RN-F)

Capability of Breaker: 32A

RY42PETLK + FDYM42PEVLK
RY48PETLK + FDYM48PEVLK

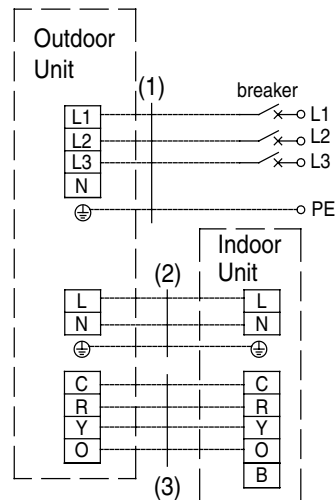

POWER 220V 3 ~ 60HZ

- (1) Power Cord 4 × 6.0mm² (H07RN-F)
- (2) Power Cord 3 × 1.0mm² (H07RN-F)
- (3) Communication Cords 4 × 1.0mm² (H07RN-F)

Capability of Breaker: 32A

R42PEYLK + FDM42PEVLK
R48PEYLK + FDM48PEVLK

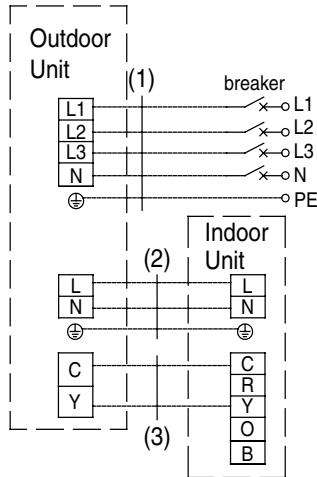

POWER 380V 3N ~ 60HZ

- (1) Power Cord $5 \times 4.0\text{mm}^2$ (H07RN-F)
 - (2) Power Cord $3 \times 1.0\text{mm}^2$ (H07RN-F)
 - (3) Communication Cords $2 \times 1.0\text{mm}^2$ (H07RN-F)
- Capability of Breaker: 25A**

RY42PEYLK + FDYM42PEVLK
RY48PEYLK + FDYM48PEVLK

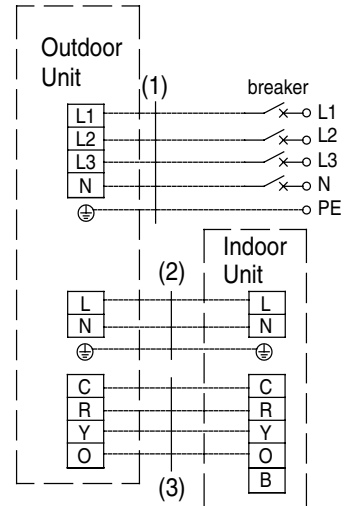

POWER 380V 3N ~ 60HZ

- (1) Power Cord $5 \times 4.0\text{mm}^2$ (H07RN-F)
 - (2) Power Cord $3 \times 1.0\text{mm}^2$ (H07RN-F)
 - (3) Communication Cords $4 \times 1.0\text{mm}^2$ (H07RN-F)
- Capability of Breaker: 25A**

9.13 Troubleshooting and Maintenance

If your air-conditioning unit suffers from abnormal operation or failure, please check the following points first before repair:

Failure	Possible Reasons
The unit cannot be started.	<ol style="list-style-type: none"> 1. The power supply is not connected. 2. Electrical leakage of air-conditioning unit causes tripping of leakage switch. 3. The voltage of electrical line is too low. 4. The operating keys are locked. 5. The control loop has failure.
The unit operates for a while and then stops.	<ol style="list-style-type: none"> 1. There is obstacle in front of the condenser. 2. The control loop is abnormal. 3. Cooling operation is selected when the outdoor ambient temperature is above 52°C.
Poor cooling effect.	<ol style="list-style-type: none"> 1. The air filter is dirty or blocked. 2. There is heat source or too many people inside the room. 3. The door or window is open. 4. There is obstacle at the air intake or outlet. 5. The set temperature is too high thus cooling is hindered. 6. There is refrigerant leakage. 7. The performance of room temperature sensor becomes worse.
Poor heating effect.	<ol style="list-style-type: none"> 1. The air filter is dirty or blocked. 2. The door or window is not firmly closed. 3. The set room temperature is too low thus heating is hindered. 4. There is refrigerant leakage. 5. The outdoor ambient temperature is lower than -7°C. 6. Control line is abnormal.
The indoor fan does not start under the heating mode.	<ol style="list-style-type: none"> 1. The installation site of the tube sensor is not proper. 2. Tube sensor is not correctly plugged. 3. The connecting line of the tube sensor is broken. 4. The capacitance has leakage.

Note: After carrying out the check of the above items and taking relevant measures to solve the problems found but the air-conditioning unit still does not function well, please stop the operation of the unit immediately and contact the local service agency. Only ask professional serviceman to check and repair the unit.

9.13.1 Cleaning the Air Filter

- (1) Do not disassemble the air filter when cleaning it. Otherwise failure may be caused.
- (2) If the air-conditioning unit is used in an environment with much dust, you should clean the air filter frequently (once every two weeks).

CAUTION

You shall pay attention to the following matters when cleaning the air-conditioning unit.

- 1) Cut off all power supply before contacting the line connecting equipment.
- 2) Only clean the air-conditioning unit after the unit is shut off and the power supply is disconnected. Otherwise electrical shock or injury may be caused.
- 3) Do not use water to clean the air-conditioning unit. Otherwise there may be electrical shock.
- 4) Take care when cleaning the air-conditioning unit. Use a steady stepping stand.

9.13.2 Maintenance at the Beginning of Operating Season

- (1) Check the air inlet and outlet of the indoor and outdoor units to confirm there is no blockage.
- (2) Check if the grounding cable is in good condition;
- (3) Check if the cable connection is in good condition;
- (4) Check if there is any word displaying on the LCD of the wired controller after connecting the unit to power supply.

Note: If there is any abnormal condition, ask after sales personnel to offer guidance.

9.13.3 Maintenance at the End of the Operational Season

- (1) When the weather is clear, operate the unit under fan mode for half a day, so as to dry the inside of the unit.
- (2) If not to use the air-conditioning unit for a long time, please disconnect the power supply. The words on the LCD of the wired controller shall disappear.

WARNING

- Please seek an authorized repair station for installation work. Improper installation might cause water leakage, electric shock or fire.
 - Please install at a place strong enough to support the weight of air conditioner unit. If not, the air conditioner unit might fall down and cause human injury or death.
 - To ensure proper drainage, the drainage pipe shall be correctly installed according to installation instructions. Take proper measures for heat preservation to prevent condensing. Improper installation of pipes might cause leakage and wet the articles in the room.
 - Do not use or store flammable, explosive, poisonous or other dangerous substances beside the air conditioner.
 - In case of trouble (e.g. burnt smell), please immediately cut off the main power of air conditioner unit.
 - Keep air flow to avoid shortage of oxygen in the room.
 - Never insert your finger or any objects into air outlet and inlet grill.
 - Never plug or unplug the power cable directly to start or stop the air-conditioning unit.
 - Please take constant care to check if the mounting rack is damaged after long use.
 - Never modify the air conditioner. Please contact the dealer or professional installation workers for repair or relocation of the air conditioner.
 - The appliance shall not be installed in the laundry.
-

Appendix:**Air conditioner nominal working condition and working range:**

Test condition	Indoor side		Outdoor side	
	DB(°C)	WB(°C)	DB(°C)	WB(°C)
Nominal cooling	27	19	35	24
Nominal heating	20	–	7	6
Rated cooling	32	23	52	31
Low temp. cooling	21	15	18	–
Rated heating	27	–	24	18
Low temp. heating	20	–	–7	–8

Note:

1. The design of this unit conforms to the requirements of ISO 13253 standard.
2. The air volume is tested at the relevant standard external static pressure.
3. Cooling (heating) capacity stated above is tested under nominal working conditions corresponding to standard external static pressure. The parameters are subject to change with the improvement of products, in which case the values on nameplate shall prevail.

⚠ WARNING

- This appliance is not intended for use by persons (including children) with reduced physical sensory or capabilities, or lack of experience and knowledge, unless they have been given supervision on instruction concerning use of appliance by a person responsible for their safety.
- Children should be supervised to ensure that they do not play with the appliance.

Note: This product is not designed for re-packing. In case of repacking, contact to Daikin Dealer. (SASO requirement).



This product must not be disposed together with the domestic waste. This product has to be disposed at an authorized place for recycling of electrical and electronic appliances.

X SPECIFICATIONS

INDOOR UNIT		FDM24PEVLK	FDM30PEVLK	FDM36PEVLK	FDM42PEVLK
OUTDOOR UNIT		R24PEVLK	R30PEVLK	R36PEVLK	R42PETLK
RATED VOLTAGE	V	220	220	220	220
RATED FREQUENCY	Hz	60	60	60	60
COOLING(T1)	RATED POWER INPUT	kW	3.30	4.00	5.28
	RATED CURRENT INPUT	A	15.8	19.4	16.4
	CAPACITY	kW	8.2	9.4	12.0
COOLING(T3)	EER	Btu/h	28000	32000	41000
	RATED POWER INPUT	(Btu/h)/W	8.75	8.00	7.77
	RATED CURRENT INPUT	kW	3.04	4.80	6.22
REFRIGERANT	RATED POWER INPUT	A	18.7	22.5	18.6
	CAPACITY	kW	5.8	7.1	10.8
	EER	Btu/h	19800	24100	36900
REFRIGERANT	(Btu/h)/W	6.51	6.18	6.04	5.93
REFRIGERANT		R22	R22	R22	R22
MASS OF REFRIGERANT CHARGE	kg	2.1	2.9	3.4	4.2
WEIGHT OF INDOOR UNIT	kg	37	37	57	57
WEIGHT OF OUTDOOR UNIT	kg	55	68	68	109
COUNTRY OF ORIGIN		MADE IN CHINA			

INDOOR UNIT		FDM42PEVLK	FDM48PEVLK	FDM48PEVLK
OUTDOOR UNIT		R42PEYLK	R48PETLK	R48PEYLK
RATED VOLTAGE	V	380	220	380
RATED FREQUENCY	Hz	60	60	60
COOLING(T1)	RATED POWER INPUT	kW	5.76	5.76
	RATED CURRENT INPUT	A	17.7	8.8
	CAPACITY	kW	12.0	13.2
COOLING(T3)	EER	Btu/h	41000	45000
	RATED POWER INPUT	(Btu/h)/W	7.77	7.81
	RATED CURRENT INPUT	kW	6.22	6.85
REFRIGERANT	RATED POWER INPUT	A	10.2	10.7
	CAPACITY	kW	10.8	11.5
	EER	Btu/h	36900	39200
REFRIGERANT	(Btu/h)/W	5.93	5.72	5.72
REFRIGERANT		R22	R22	R22
MASS OF REFRIGERANT CHARGE	kg	4.5	4.3	4.2
WEIGHT OF INDOOR UNIT	kg	57	57	57
WEIGHT OF OUTDOOR UNIT	kg	109	109	109
COUNTRY OF ORIGIN		MADE IN CHINA		

INDOOR UNIT			FDYM24PEVLK	FDYM30PEVLK	FDYM36PEVLK	FDYM42PEVLK
OUTDOOR UNIT			RY24PEVLK	RY30PEVLK	RY36PEVLK	RY42PETLK
RATED VOLTAGE	V		220	220	220	220
RATED FREQUENCY	Hz		60	60	60	60
RATED POWER INPUT	kW		2.70	3.45	4.00	5.17
RATED CURRENT INPUT	A		13.0	16.5	19.0	16.2
COOLING(T1)	kW		6.6	8.2	9.4	12.0
	Btu/h		22500	28000	32000	41000
EER	(Btu/h)/W		8.34	8.12	8.00	7.93
RATED POWER INPUT	kW		3.10	4.15	4.80	6.20
RATED CURRENT INPUT	A		15.0	19.5	22.0	18.6
COOLING(T3)	kW		6.1	7.1	8.6	10.7
	Btu/h		20800	23800	29300	36500
EER	(Btu/h)/W		6.71	5.73	6.10	5.89
RATED POWER INPUT	kW		2.60	3.40	3.50	5.27
RATED CURRENT INPUT	A		12.5	16.0	16.0	17.1
HEATING	kW		7.5	9.3	10.5	14.0
	Btu/h		25600	31700	35800	48000
COP	W/W		2.88	2.74	3.00	2.66
REFRIGERANT			R22	R22	R22	R22
MASS OF REFRIGERANT CHARGE	kg		2.1	2.9	3.4	4.5
WEIGHT OF INDOOR UNIT	kg		37	37	57	57
WEIGHT OF OUTDOOR UNIT	kg		55	68	68	109
COUNTRY OF ORIGIN			MADE IN CHINA			

INDOOR UNIT			FDYM42PEVLK	FDYM48PEVLK	FDYM48PEVLK
OUTDOOR UNIT			RY42PEYLK	RY48PETLK	RY48PEVLK
RATED VOLTAGE	V		380	220	380
RATED FREQUENCY	Hz		60	60	60
RATED POWER INPUT	kW		5.17	5.79	5.79
RATED CURRENT INPUT	A		8.6	18.4	9.8
COOLING(T1)	kW		12.0	13.2	13.2
	Btu/h		41000	45000	45000
EER	(Btu/h)/W		7.93	7.77	7.77
RATED POWER INPUT	kW		6.20	7.01	7.01
RATED CURRENT INPUT	A		10.3	21.4	11.9
COOLING(T3)	kW		10.7	11.7	11.7
	Btu/h		36500	40000	40000
EER	(Btu/h)/W		5.89	5.71	5.71
RATED POWER INPUT	kW		5.27	5.90	5.90
RATED CURRENT INPUT	A		9.2	19.3	10.5
HEATING	kW		14.0	16.0	16.0
	Btu/h		48000	54600	54600
COP	W/W		2.66	2.71	2.71
REFRIGERANT			R22	R22	R22
MASS OF REFRIGERANT CHARGE	kg		4.6	4.4	4.4
WEIGHT OF INDOOR UNIT	kg		57	57	57
WEIGHT OF OUTDOOR UNIT	kg		109	109	109
COUNTRY OF ORIGIN			MADE IN CHINA		