

DAIKIN



R22 Split Series

OWNER'S MANUAL

MODEL

FTV25AV1	RV25AV1
FTV35AV1	RV35AV1
FTV50AV1	RV50AV1
FTV60AV1	RV60AV1

Disposal requirements



Your product and the batteries supplied with the controller are marked with this symbol. This symbol means that electrical and electronic products and batteries shall not be mixed with unsorted household waste. For batteries, a chemical symbol can be printed beneath the symbol. This chemical symbol means that the battery contains a heavy metal above a certain concentration. Possible chemical symbols are:

- Pb: lead (>0.004%)

Do not try to dismantle the system yourself: the dismantling of the product, treatment of the refrigerant, of oil and of other parts must be done by a qualified installer in accordance with relevant local and national legislation. Units and waste batteries must be treated at a specialized treatment facility for re-use, recycling and recovery. By ensuring correct disposal, you will help to prevent potential negative consequences for the environment and human health. Please contact the installer or local authority for more information.

Content

Operation Notices

Safety Precautions.....	1
Parts Name.....	3

Installation Notice

Installation dimension diagram	4
Tools for installation	5
Selection of installation location.....	5
Requirements for electric connection	6

Installation

Installation of indoor unit.....	7
Installation of outdoor unit.....	12
Vacuum pumping.....	15
Leakage detection	15
Check after installation	16

Test and operation

Test operation	16
----------------------	----

Attachment

Configuration of connection pipe	17
Pipe expanding method	18

Screen Operation Guide

Buttons on remote controller.....	19
Introduction to icons on display screen.....	19
Introduction to buttons on remote controller	20
Introduction to functions of combination buttons	23
Operation guide	24
Replacement of batteries in remote controller	24
Emergency operation.....	25

Maintenance

Cleaning and Maintenance	25
--------------------------------	----

Malfunction

Malfunction analysis	28
Wiring.....	31



Safety Precautions

- The precautions described herein are classified as WARNING and CAUTION. They both contain important information regarding safety. Be sure to observe all precautions without fail.
- Meaning of WARNING and CAUTION notices





 **WARNING** Failure to follow these instructions properly may result in personal injury or loss of life.

 **CAUTION** Failure to observe these instructions properly may result in property damage or personal injury, which may be serious depending on the circumstances.

- The safety marks shown in this manual have the following meanings:

 Be sure to follow the instructions.	 Be sure to establish an earth connection.	 Never attempt.
---	---	--

- After completing installation, conduct a trial operation to check for faults and explain to the customer how to operate the air conditioner and take care of it with the aid of the operation manual.
- The English text is the original instruction. Other languages are translations of the original instructions.

 WARNING	
<ul style="list-style-type: none"> • Ask your dealer or qualified personnel to carry out installation work. Do not attempt to install the air conditioner yourself. Improper installation may result in water leakage, electric shocks or fire. 	
<ul style="list-style-type: none"> • Install the air conditioner in accordance with the instructions in this installation manual. Improper installation may result in water leakage, electric shocks or fire. 	
<ul style="list-style-type: none"> • Be sure to use only the specified accessories and parts for installation work. Failure to use the specified parts may result in the unit falling, water leakage, electric shocks or fire. 	
<ul style="list-style-type: none"> • Install the air conditioner on a foundation strong enough to withstand the weight of the unit. A foundation of insufficient strength may result in the equipment falling and causing injury. 	
<ul style="list-style-type: none"> • Electrical work must be performed in accordance with relevant local and national regulations and with instructions in this installation manual. Be sure to use a dedicated power supply circuit only. Insufficiency of power circuit capacity and improper workmanship may result in electric shocks or fire. 	
<ul style="list-style-type: none"> • Use a cable of suitable length. Do not use tapped wires or an extension lead, as this may cause overheating, electric shocks or fire. 	
<ul style="list-style-type: none"> • Make sure that all wiring is secured, the specified wires are used, and that there is no strain on the terminal connections or wires. Improper connections or securing of wires may result in abnormal heat build-up or fire. 	
<ul style="list-style-type: none"> • When wiring the power supply and connecting the wiring between the indoor and outdoor units, position the wires so that the control box lid can be securely fastened. Improper positioning of the control box lid may result in electric shocks, fire or over heating terminals. 	
<ul style="list-style-type: none"> • If refrigerant gas leaks during installation, ventilate the area immediately. Toxic gas may be produced if the refrigerant comes into contact with fire. 	
<ul style="list-style-type: none"> • After completing installation, check for refrigerant gas leakage. Toxic gas may be produced if the refrigerant gas leaks into the room and comes into contact with a source of fire, such as a fan heater, stove or cooker. 	
<ul style="list-style-type: none"> • When installing or relocating the air conditioner, be sure to bleed the refrigerant circuit to ensure it is free of air, and use only the specified refrigerant (R22). The presence of air or other foreign matter in the refrigerant circuit causes abnormal pressure rise, which may result in equipment damage and even injury. 	
<ul style="list-style-type: none"> • During installation, attach the refrigerant piping securely before running the compressor. If the compressor is not attached and the stop valve is open when the compressor is run, air will be sucked in, causing abnormal pressure in the refrigeration cycle, which may result in equipment damage and even injury. 	
<ul style="list-style-type: none"> • During pump-down, stop the compressor before removing the refrigerant piping. If the compressor is still running and the stop valve is open during pump-down, air will be sucked in when the refrigerant piping is removed, causing abnormal pressure in the refrigeration cycle, which may result in equipment damage and even injury. 	
<ul style="list-style-type: none"> • Be sure to earth the air conditioner. Do not earth the unit to a utility pipe, lightning conductor or telephone earth lead. Imperfect earthing may result in electric shocks. 	
<ul style="list-style-type: none"> • Be sure to install an earth leakage breaker. Failure to install an earth leakage breaker may result in electric shocks or fire. 	
<ul style="list-style-type: none"> • Do not touch any electronic component or terminal when the machine is running, stopping or has been powered off for less than 30 minutes to prevent the risk of electric shock! 	

⚠ CAUTION

- Do not install the air conditioner at any place where there is a danger of flammable gas leakage. In the event of a gas leakage, build-up of gas near the air conditioner may cause a fire to break out. 
- While following the instructions in this installation manual, install drain piping to ensure proper drainage and insulate piping to prevent condensation. Improper drain piping may result in indoor water leakage and property damage.
- Tighten the flare nut according to the specified method such as with a torque wrench. If the flare nut is too tight, it may crack after prolonged use, causing refrigerant leakage.
- Make sure to provide for adequate measures in order to prevent that the outdoor unit be used as a shelter by small animals. Small animals making contact with electrical parts can cause malfunctions, smoke or fire. Please instruct the customer to keep the area around the unit clean.
- This appliance is intended to be used by expert or trained users in shops, in light industry and on farms, or for commercial and household use by lay persons.
- Sound pressure level is less than 70 dB(A).
- NOTE: Motor ground only applies to the iron shell motor.
- This appliance is not intended for use by persons, including children, with reduced physical, sensory or mental capabilities, or lack of experience and knowledge, unless they have been given supervision or instruction concerning use of the appliance by a person responsible for their safety. Children shall be supervised to ensure that they do not play with the appliance.

Working temperature range

	Indoor side DB/WB(°C)	Outdoor side DB/WB(°C)
Maximum cooling	32/23	43/26

- The operating temperature range (outdoor temperature) is 18 - 43°C for cooling.

Parts Name

Indoor Unit

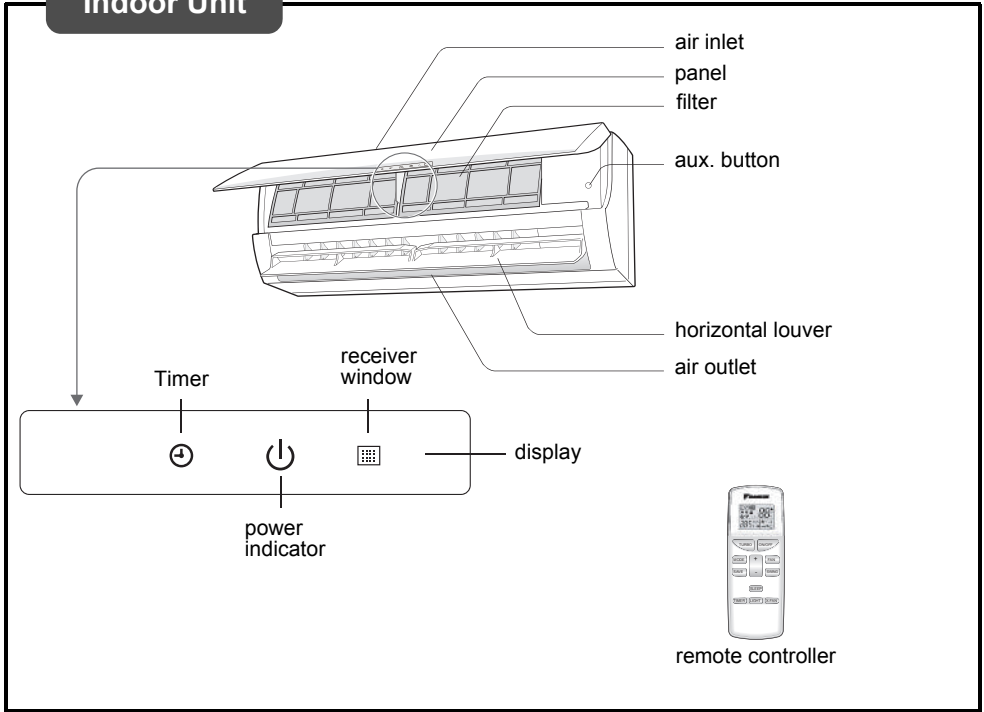

Outdoor Unit

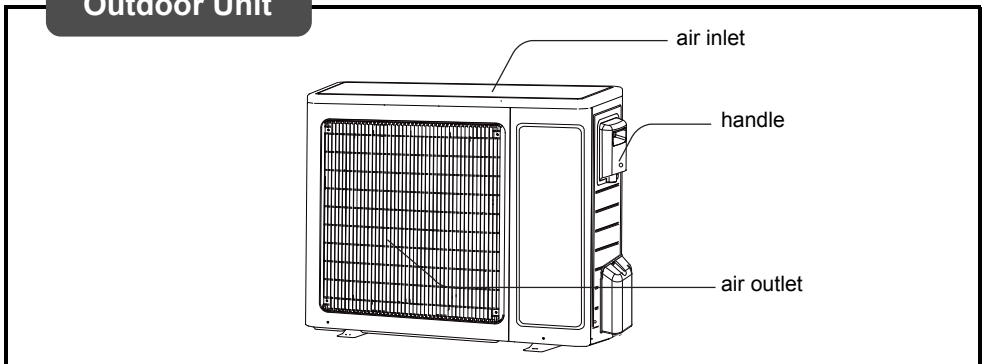

Installation dimension diagram

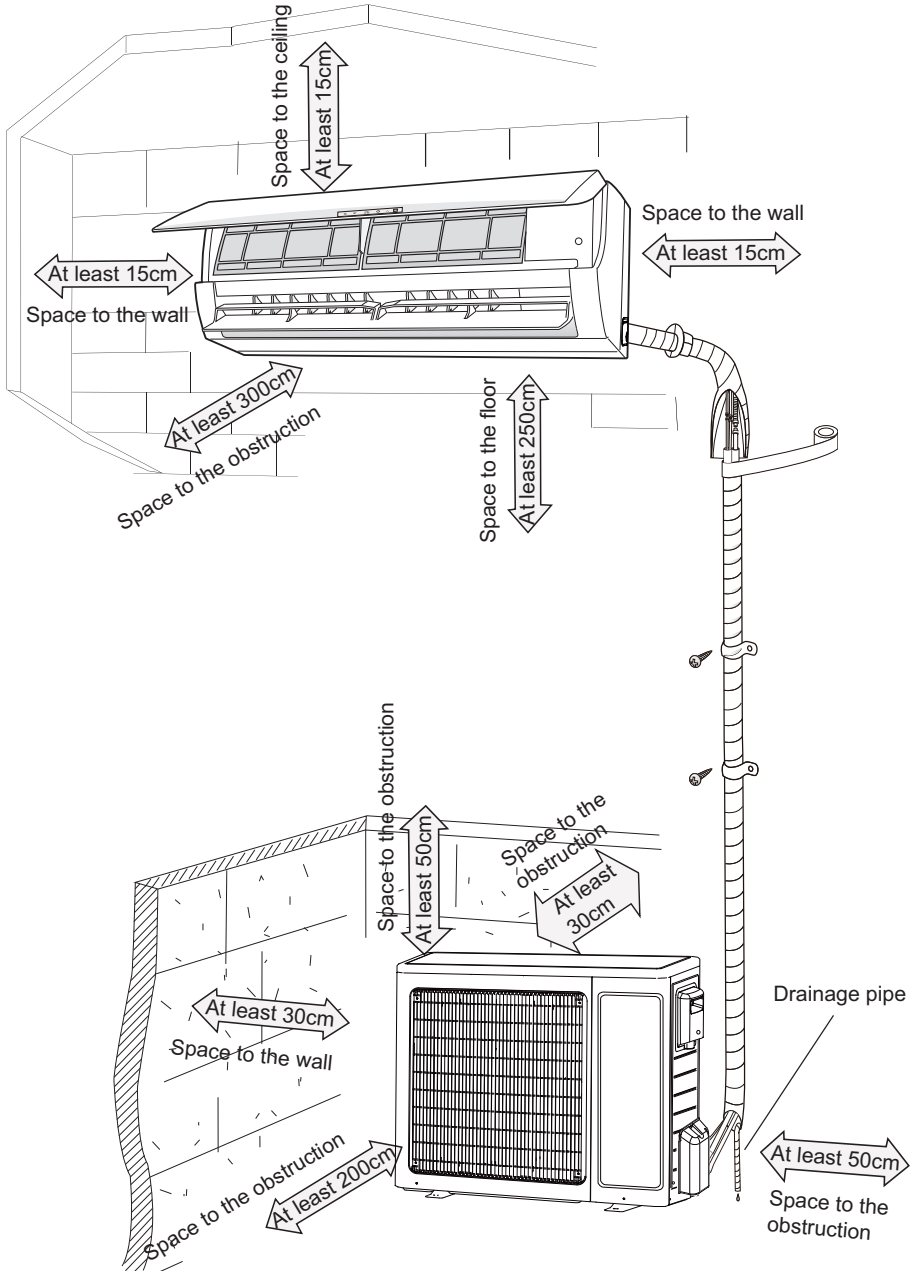

Tools for installation

1 Level meter	2 Screw driver	3 Impact drill
4 Drill head	5 Pipe expander	6 Torque wrench
7 Open-end wrench	8 Pipe cutter	9 Leakage detector
10 Vacuum pump	11 Pressure meter	12 Universal meter
13 Inner hexagon spanner	14 Measuring tape	

Note:

- Please contact the local agent for installation.
- Don't use unqualified power cord.

Selection of installation location

Basic requirement	Indoor unit
<p>Installing the unit in the following places may cause malfunction. If it is unavoidable, please consult the local dealer:</p> <ol style="list-style-type: none"> 1. The place with strong heat sources, vapors, flammable or explosive gas, or volatile objects spread in the air. 2. The place with high-frequency devices (such as welding machine, medical equipment). 3. The place near coast area. 4. The place with oil or fumes in the air. 5. The place with sulfureted gas. 6. Other places with special circumstances. 7. The appliance shall not be installed in the laundry. 	<ol style="list-style-type: none"> 1. There should be no obstruction near air inlet and air outlet. 2. Select a location where the condensation water can be dispersed easily and won't affect other people. 3. Select a location which is convenient to connect the indoor unit and near the power socket. 4. Select a location which is out of reach for children. 5. The location should be able to withstand the weight of indoor unit and won't increase noise and vibration. 6. The appliance must be installed 2.5m above floor 7. Don't install the indoor unit right above the electric appliance. 8. Please try your best to keep away from fluorescent lamp.
Outdoor unit	
<ol style="list-style-type: none"> 1. Select a location where the noise and outflow air emitted by the outdoor unit will not affect the neighborhood. 2. The location should be well ventilated and dry, in which the outdoor unit won't be exposed directly to sunlight or strong wind. 3. The location should be able to withstand the weight of outdoor unit. 4. Make sure that the installation follows the requirements of installation dimension diagram. 5. Select a location which is out of reach for children and far away from animals or plants. If it is unavoidable, please add the fence for safety purpose. 	

Requirements for electric connection

Safety precaution

1. The electric safety regulations must be followed when installing the unit.
2. According to the local safety regulations, use qualified power supply circuit and earth leakage circuit breaker.
3. Make sure the power supply matches with the requirement of air conditioner. Unstable power supply or incorrect wiring may result in electric shock, fire hazard or malfunction. Please install proper power supply cables before using the air conditioner.
4. Properly connect the live wire, neutral wire and grounding wire of power socket.
5. Be sure to cut off the power supply before proceeding any work related to electricity and safety.
6. Do not put through the power before finishing installation.
7. If the supply cord is damaged, it must be replaced by the manufacturer, its service agent or similarly qualified persons in order to avoid hazard.
8. The temperature of refrigerant circuit will be high, please keep the interconnection cable away from the copper tube.
9. The appliance shall be installed in accordance with national wiring regulations.

Grounding requirement

1. The air conditioner is the first class electric appliance. It must be properly grounded with specialized grounding device by a professional. Please make sure it is always grounded effectively, otherwise it may cause electric shock.
2. The yellow-green wire in air conditioner is grounding wire, which can't be used for other purposes.
3. The grounding resistance should comply with national electric safety regulations.
4. The appliance must be positioned so that the plug is accessible.
5. An all-pole disconnection switch having a contact separation of at least 3mm in all poles should be connected in fixed wiring.
6. Be sure to install an earth leakage breaker capable of handling maximum rated current. (One that can handle higher harmonics.)

Installation of indoor unit

Step one: choosing installation location

Recommend the installation location to the client and then confirm it with the client.

Step two: install wall-mounting frame

1. Hang the wall-mounting frame on the wall; adjust it in horizontal position with the level meter and then point out the screws fixing holes on the wall.
2. Drill the screw fixing holes on the wall with impact drill (the specification of drill head should be the same as the plastic expansion particle) and then fill the plastic expansion particles in the holes.
3. Fix the wall-mounting frame on the wall with tapping screws (ST4.2X25TA) and then check if the frame is firmly installed by pulling the frame. If the plastic expansion particle is loose, please drill another fixing hole nearby.

Step three: open piping hole

1. Choose the position of piping hole according to the direction of outlet pipe.
The position of piping hole should be a little lower than the wall-mounted frame, shown as below.

25, 35 and 50 class:

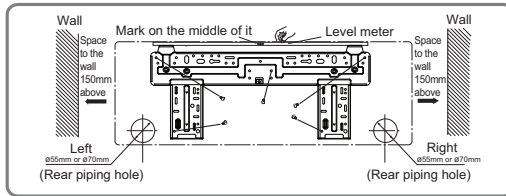

60 class:

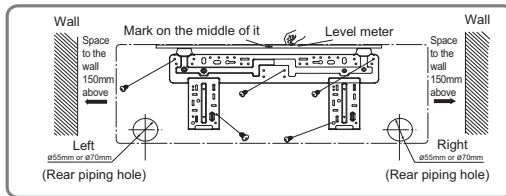

2. Open a piping hole with the diameter of $\text{Ø}55$ or $\text{Ø}70$ on the selected outlet pipe position. In order to drain smoothly, slant the piping hole on the wall slightly downward to the outdoor side with the gradient of $5\text{--}10^\circ$.

Installation of indoor unit

Piping hole	Model
Ø55	Cooling capacity < 6000W
Ø70	Cooling capacity ≥ 6000W

Note:

- Pay attention to dust prevention and take relevant safety measures when opening the hole.
- The plastic expansion particles are not provided and should be bought locally.

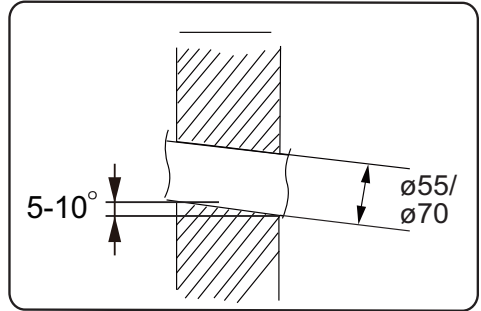

Step four: outlet pipe

1. The pipe can be led out in the direction of right, rear right, left or rear left.

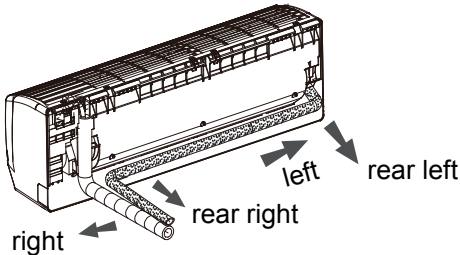

2. When selecting leading out the pipe from left or right, please cut off the corresponding hole on the bottom case.

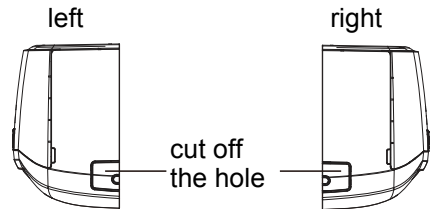

Step five: connect the pipe of indoor unit

1. Aim the pipe joint at the corresponding bellmouth.
2. Pretightening the union nut with hand.

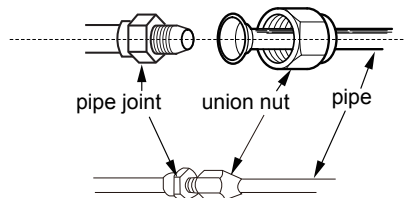

3. Adjust the torque force by referring to the following sheet. Place the open-end wrench on the pipe joint and place the torque wrench on the union nut. Tighten the union nut with torque wrench.

Installation of indoor unit

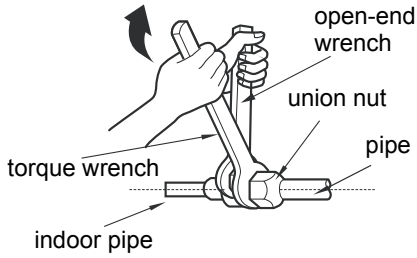

Hex nut diameter	Tightening torque (N·m)
Ø 6	15~20
Ø 9.52	30~40
Ø 12	40~55
Ø 16	60~65
Ø 19	70~75

4. Wrap the indoor pipe and joint of connection pipe with insulating pipe, and then wrap it with tape.

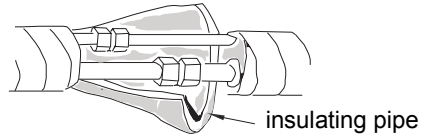

Step six: install drain hose

1. Connect the drain hose to the outlet pipe of indoor unit.

2. Bind the joint with tape.

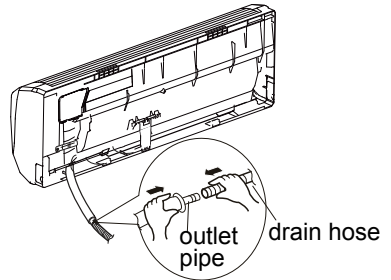
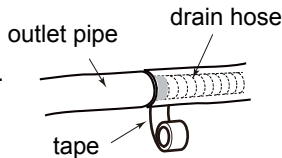

Note:

- Add insulating pipe in the indoor drain hose in order to prevent condensation.
- The plastic expansion particles are not provided.

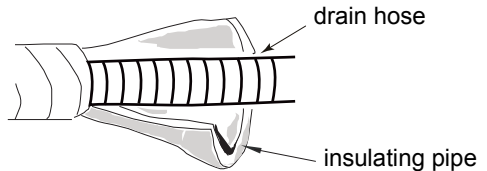

Step seven: connect wire of indoor unit

1. Open the panel, remove the screw on the wiring cover and then take down the cover.

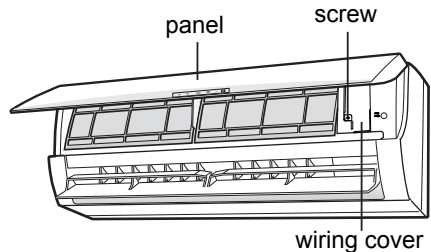

Installation of indoor unit

2. Make the power connection wire go through the cable-cross hole at the back of indoor unit and then pull it out from the front side.

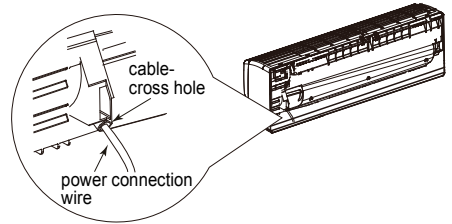

3. Remove the wire clip; connect the power connection wire to the wiring terminal according to the color; tighten the screw and then fix the power connection wire with wire clip.

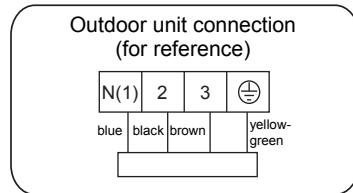
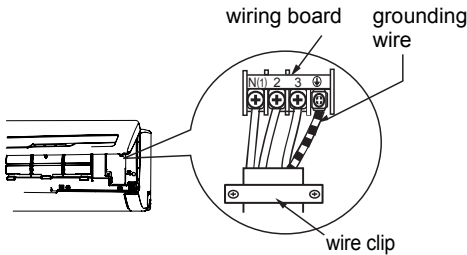

Note: the wiring board is for reference only, please refer to the actual one.

4. Put wiring cover back and then tighten the screw.

5. Close the panel.

Note:

- All wires of indoor unit and outdoor unit should be connected by a professional.
- If the length of power connection wire is insufficient (see table below), please contact the supplier for a new one. Avoid extending the wire by yourself.

Class:	Length of Connecting Wire (mm)	
25	1800	
35	1800	
50	2000	
60	2000	

- A circuit breaker must be installed for the air conditioner in serial connection.

Installation of indoor unit

Step eight: bind up pipe

1. Bind up the connection pipe, power cord and drain hose with the band.

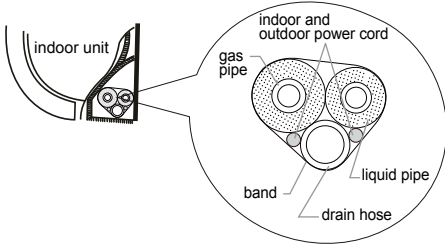

2. Reserve a certain length of drain hose and power cord for installation when binding them. When binding to a certain degree, separate the indoor power and then separate the drain hose.

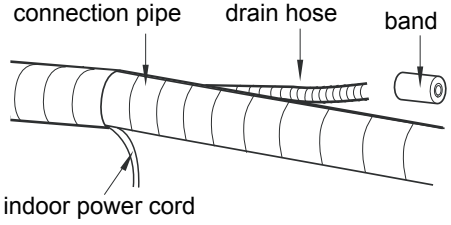

3. Bind them evenly.
4. The liquid pipe and gas pipe should be bound separately at the end.

Note:

- The power cord and control wire can't be crossed or winding.
- The drain hose should be bound at the bottom.

Step nine: hang the indoor unit

1. Put the bound pipes in the wall pipe and then make them pass through the wall hole.
2. Hang the indoor unit on the wall-mounting frame.
3. Stuff the gap between pipes and wall hole with sealing gum.
4. Fix the wall pipe.
5. Check if the indoor unit is installed firmly and closed to the wall.

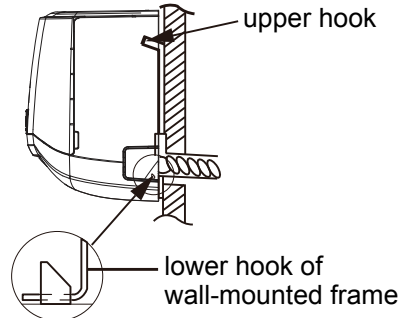
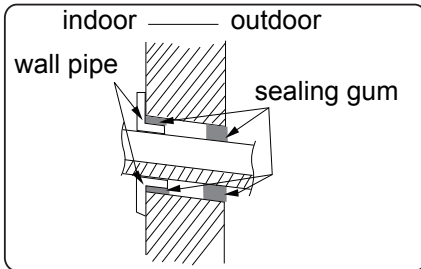

Note:

- Do not bend the drain hose too excessively in order to prevent blocking.

Installation of outdoor unit

Step one: fix the support of outdoor unit (select it according to the actual installation situation)

1. Select installation location according to the house structure.
2. Fix the support of outdoor unit on the selected location with expansion screws.

Note:

- Take sufficient protective measurements when installing outdoor unit.
- Make sure the support can withstand at least four times of the unit weight.
- The outdoor unit should be installed at least 3cm above the floor in order to install drain joint.
- For the unit with cooling capacity of 2300W ~5000W, 6 expansion screws are needed; for the unit with cooling capacity of 6000W ~8000W, 8 expansion screws are needed; for the unit with cooling capacity of 10000W ~16000W, 10 expansion screws are needed.

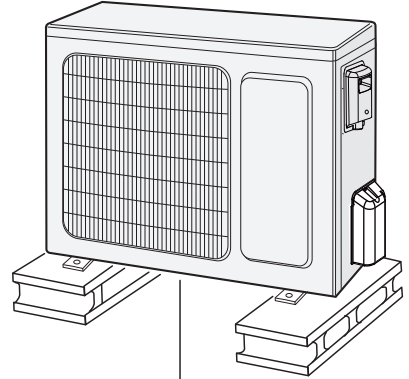

Step two: install drain joint (Only for cooling and heating unit)

1. Connect the outdoor drain joint into the hole on the chassis, as shown in the picture below.
2. Connect the drain hose into the drain vent.

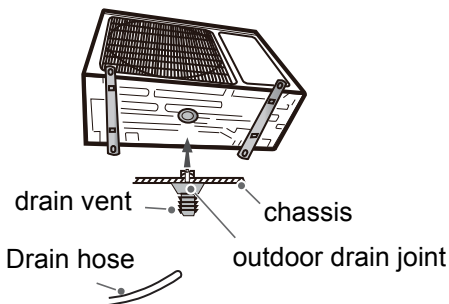

Step three: fix outdoor unit

1. Place the outdoor unit on the support.
2. Fix the foot holes of outdoor unit with bolts.

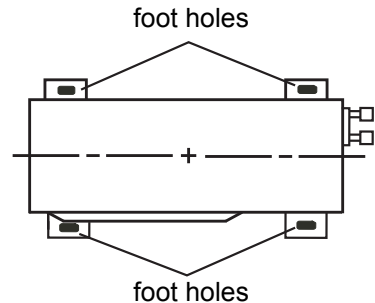

Installation of outdoor unit

Step four: connect indoor and outdoor pipes

1. Remove the screw on the right handle of outdoor unit and then remove the handle.

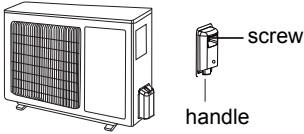

2. Remove the screw cap of valve and aim the pipe joint at the bellmouth of pipe.

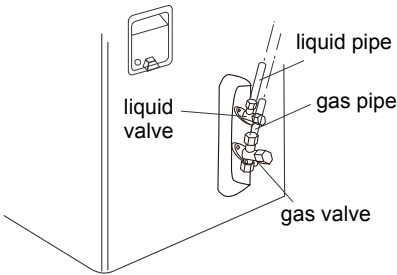

3. Pretightening the union nut with hand.

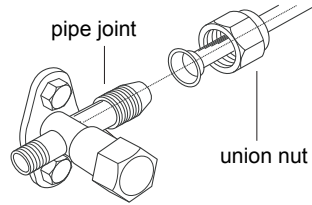

4. Tighten the union nut with torque wrench by referring to the sheet below.

Hex nut diameter	Tightening torque (N·m)
Ø 6	15~20
Ø 9.52	30~40
Ø 12	40~55
Ø 16	60~65
Ø 19	70~75

Step five: connect outdoor electric wire

1. Remove the wire clip; connect the power connection wire and signal control wire (only for cooling and heating unit) to the wiring terminal according to the color; fix them with screws.

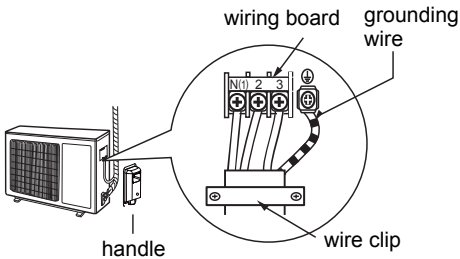

Indoor unit connection (for reference)

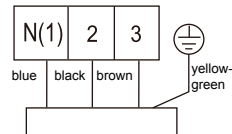

Installation of outdoor unit

2. Fix the power connection wire and signal control wire with wire clip (only for cooling and heating unit).

Note:

- After tightening the screw, pull the power cord slightly to check if it is firm.

Step six: neatn the pipes

1. The pipes should be placed along the wall, bent reasonably and hidden possibly. Min. semidiameter of bending the pipe is 10cm.
2. If the outdoor unit is higher than the wall hole, you must set a U-shaped curve in the pipe before pipe goes into the room, in order to prevent rain from getting into the room.

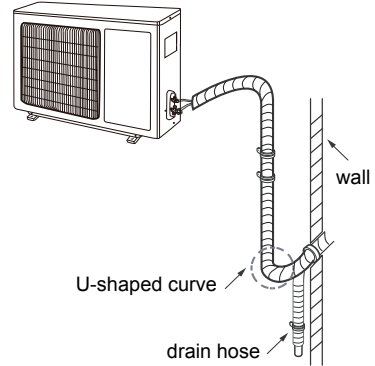

Note:

- The through-wall height of drain hose shouldn't be higher than the outlet pipe hole of indoor unit.
- Slant the drain hose slightly downwards. The drain hose can't be curved, raised and fluctuant, etc.

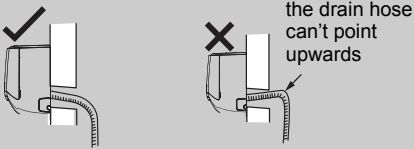

- The water outlet can't be placed in water in order to drain smoothly.

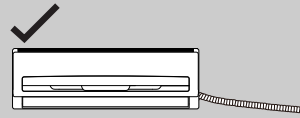
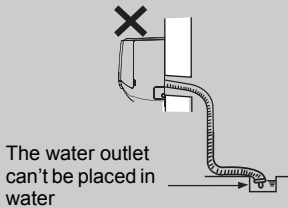

- The drain hose can't be fluctuant

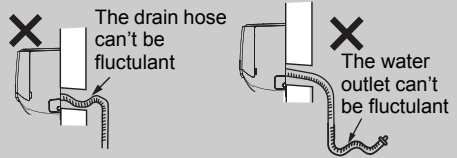
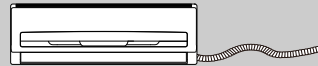

Vacuum pumping

Use vacuum pump

1. Remove the valve caps on the liquid valve and gas valve and the nut of refrigerant charging vent.
2. Connect the charging hose of piezometer to the refrigerant charging vent of gas valve and then connect the other charging hose to the vacuum pump.
3. Open the piezometer completely and operate for 10-15min to check if the pressure of piezometer remains in -0.1MPa .
4. Close the vacuum pump and maintain this status for 1-2min to check if the pressure of piezometer remains in -0.1MPa .

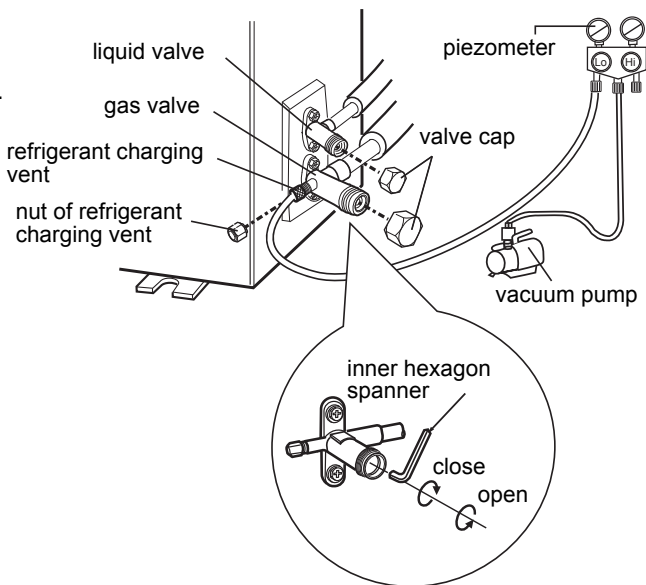

- If the pressure decreases, there may be leakage.
5. Remove the piezometer, open the valve core of liquid valve and gas valve completely with inner hexagon spanner.
 6. Tighten the screw caps of valves and refrigerant charging vent.

Leakage detection

1. With leakage detector:
Check if there is leakage with leakage detector.
2. With soap water:
If leakage detector is not available, please use soap water for leakage detection. Apply soap water at the suspected position and keep the soap water for more than 3min. If there are air bubbles coming out of this position, there's a leakage.

Check after installation

- Check the following requirements after finishing installation.

Items to be checked	Possible malfunction
Has the unit been installed firmly?	The unit may drop, shake or emit noise.
Have you done the refrigerant leakage test?	It may cause insufficient cooling (heating) capacity.
Is heat insulation of pipeline sufficient?	It may cause condensation and water dripping.
Is water drained well?	It may cause condensation and water dripping.
Is the voltage of power supply according to the voltage marked on the nameplate?	It may cause malfunction or damage the parts.
Is electric wiring and pipeline installed correctly?	It may cause malfunction or damage the parts.
Is the unit grounded securely?	It may cause electric leakage.
Does the power cord follow the specification?	It may cause malfunction or damage the parts.
Is there any obstruction in the air inlet and outlet?	It may cause insufficient cooling (heating) capacity.
The dust and sundries caused during installation are removed?	It may cause malfunction or damage the parts.
The gas valve and liquid valve of connection pipe are open completely?	It may cause insufficient cooling (heating) capacity.

Test operation

1. Preparation of test operation

- The client approves the air conditioner.
- Specify the important notes for air conditioner to the client.

2. Method of test operation

- Put through the power, press ON/OFF button on the remote controller to start operation.
- Press MODE button to select AUTO, COOL, DRY, FAN and HEAT to check whether the operation is normal or not.

Configuration of connection pipe

1. Min. length of connection pipe is 3m.
2. Max. length of connection pipe and max. height difference.

Cooling capacity	Max length of connection pipe	Max height difference
25 class 9000Btu/h (2637W)	15	10
35 class 12000Btu/h (3516W)	15	10
50 class 18000Btu/h (5274W)	25	10
60 class 24000Btu/h (7032W)	25	10

3. The additional refrigerant oil and refrigerant charging required after lengthening connection pipe
 - The calculation method of additional refrigerant charging amount (on the basis of liquid pipe):
Additional refrigerant charging amount = extra length of liquid pipe × additional refrigerant charging amount per meter
 - When the length of connection pipe is above 10m, add refrigerant according to the extra length of liquid pipe. The additional refrigerant charging amount per meter is different according to the diameter of liquid pipe. See the following sheet.
 - Additional refrigerant charging amount for R22, R407C, R410A and R134a

Diameter of connection pipe		Outdoor unit throttle	
Liquid pipe(mm)	Gas pipe(mm)	Cooling only(g/m)	Cooling and heating(g/m)
Ø6	Ø9.52 or Ø12	15	20
Ø6 or Ø9.52	Ø16 or Ø19	15	50
Ø12	Ø19 or Ø22.2	30	120

Pipe expanding method

Note:

Improper pipe expanding is the main cause of refrigerant leakage. Please expand the pipe according to the following steps:

A: Cut the pipe

- Confirm the pipe length according to the distance of indoor unit and outdoor unit.
- Cut the required pipe with pipe cutter.

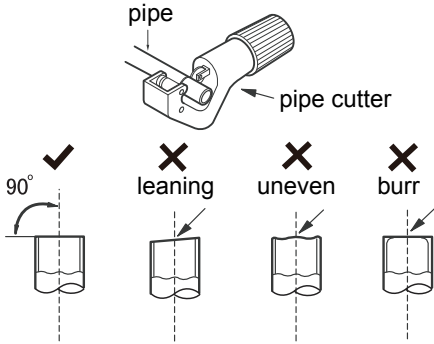

B: Remove the burrs

- Remove the burrs with shaper and prevent the burrs from getting into the pipe.

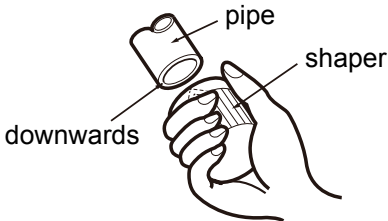

C: Put on suitable insulating pipe

D: Put on the union nut

- Remove the union nut on the indoor connection pipe and outdoor valve; install the union nut on the pipe.

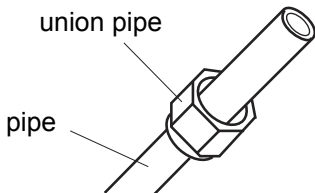

E: Expand the port

- Expand the port with expander.

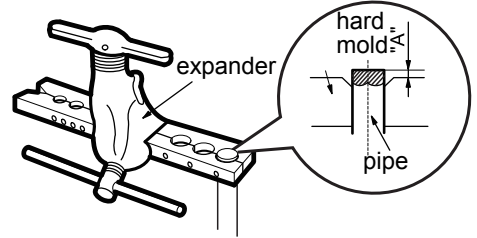

Note:

- "A" is different according to the diameter, please refer to the sheet below:

Outer diameter (mm)	A(mm)	
	Max	Min
Ø6 - 6.35(1/4")	1.3	0.7
Ø9.52(3/8")	1.6	1.0
Ø12 - 12.7(1/2")	1.8	1.0
Ø15.8 - 16(5/8")	2.4	2.2

F: Inspection

- Check the quality of expanding port. If there is any blemish, expand the port again according to the steps above.

smooth surface

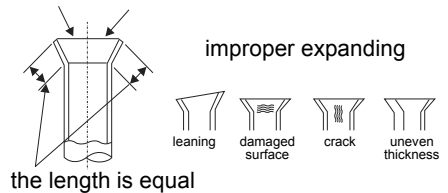

Buttons on remote controller

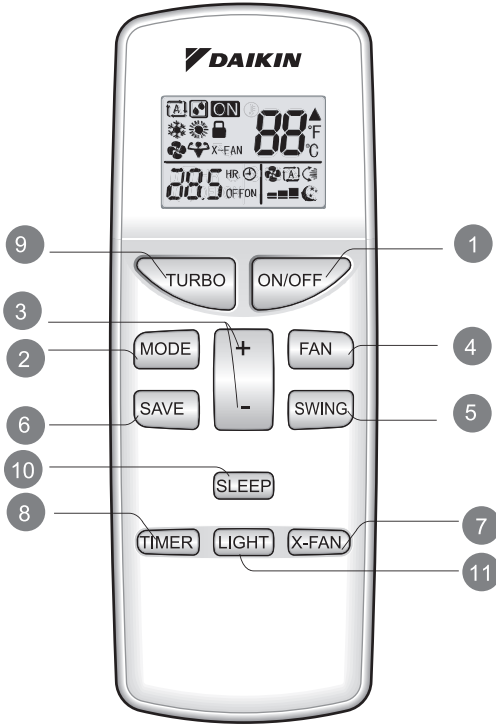

- 1 ON/OFF button
- 2 MODE button
- 3 +/- button
- 4 FAN button
- 5 SWING button
- 6 SAVE button
- 7 X-FAN button
- 8 TIMER button
- 9 TURBO button
- 10 SLEEP button
- 11 LIGHT button

Introduction to icons on display screen

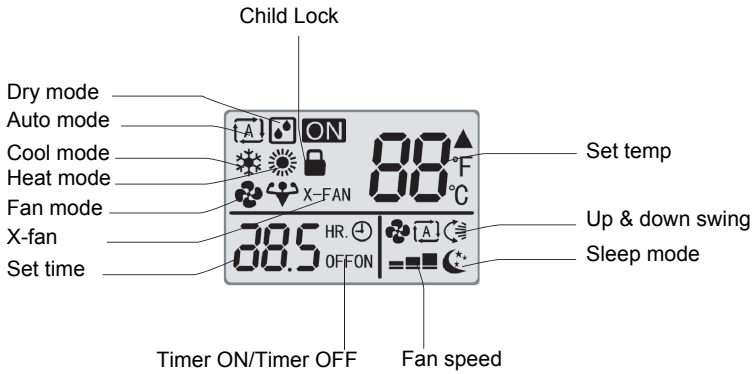

Introduction to buttons on remote controller

Note:

- After putting through power, the air conditioner will give out a sound and operation indicator "⏻" is ON (red indicator). You can operate the air conditioner through the remote controller.
- At ON status, after pressing a button on the remote controller, the signal icon "▲" on the remote controller will flash once. The air conditioner will give out a sound, which indicates the signal has been sent to the air conditioner.
- At OFF status, display screen on the remote controller displays the set temperature. At ON status, display screen on the remote controller displays the corresponding startup function icon.

1 ON/OFF button

Press this button to turn on or turn off the air conditioner. After turning on the unit, the operation indicator "⏻" on the indoor unit is ON (blue indicator. Color may be different for different models) and indoor unit gives out a sound.

2 MODE button

Press this button to select your required operation mode.



- After selecting auto mode, the air conditioner will operate automatically according to ambient temperature. The set temperature can't be adjusted and also can't be displayed. Press the "FAN" button to adjust fan speed. Press the "SWING" button to adjust swing angle.
- After selecting the cool mode, the air conditioner operates under cool mode. The cool indicator "❄️" on the indoor unit is ON. You can press the "+" or "-" buttons to adjust the set temperature. Press the "FAN" button to adjust fan speed. Press the "SWING" button to adjust the swing angle.
- After selecting the dry mode, the air conditioner operates under dry mode at low speed. The dry indicator "💧" on the indoor unit is ON. Under dry mode, fan speed can't be adjusted. Press the "SWING" to adjust the swing angle.
- After selecting the fan mode, the air conditioner operates only under fan mode, the other mode indicators on indoor unit are OFF. Press the "FAN" button to adjust fan speed. Press the "SWING" button to adjust the swing angle.
- After selecting the heat mode, the air conditioner operates under heat mode. The heat indicator "☀️" on the indoor unit is ON. You can press the "+" or "-" buttons to adjust the set temperature. Press the "FAN" button to adjust fan speed. Press the "SWING" button to adjust the swing angle. (Cooling only unit can't receive the signal for heating mode.)

Introduction to buttons on remote controller

Note:

The air conditioner is designed to start discharging air only after it has reached a certain temperature in heating mode (usually 1-5min depending on indoor ambient temperature). Temperature setting range on remote controller: 16°C-30°C. Fan speed setting range: auto, low speed, medium speed and high speed.

3 "+" or "-" button

- Each pressing of the "+" or "-" button can increase or decrease the set temperature by 1°C. Hold the "+" or "-" button for at least 2s and the set temperature on the remote controller will change quickly. After reaching to the required time, release the button.
- Under TIMER ON, TIMER OFF or Clock setting, you can press the "+" or "-" button to adjust time. (Refer to TIMER button for details)

4 FAN button

Press this button to select the fan speed in sequence: auto (AUTO), low speed (▲), medium speed (▲▲), high speed (▲▲▲).



Note:

- Under auto mode, the air conditioner will select proper fan speed according to ex-factory setting automatically.
- Low speed under dry mode.

5 SWING button

- Press this button to select up&down swing. In auto swing mode, the horizontal louver of the air conditioner will swing up&down automatically at maximum angle. This mode will be indicated on the display of the remote controller by an icon.
- Pressing "SWING" on the remote controller again will cause the horizontal louver of the air conditioner to stop moving and stay fixed at that angle. In this mode, the icon on the remote controller will disappear.

Introduction to buttons on remote controller

6

SAVE button

SAVE function:

Under cool mode, press the SAVE button and the unit will operate under SAVE mode. The remote controller will display "SE" and the air conditioner will operate at auto speed. The set temperature can't be adjusted. Press the SAVE button again to exit the SAVE mode. The air conditioner will return to the original set speed and set temperature.

- This function is only applicable to some models.

7

X-FAN button

After pressing this button under cooling or dry mode, the remote controller displays the "X-FAN" icon and the X-FAN function is started up. Press this button again to cancel the X-FAN function. The "X-FAN" icon will disappear.

Note:

- After starting up the X-FAN function, when turning off the unit, the indoor fan will continue to operate for a while at low speed to dry the residual water inside the indoor unit.
- When the unit operates under the X-FAN mode, press "X-FAN" button to turn off the X-FAN function. The indoor fan will stop operating immediately.

8

TIMER button

- At ON status, press this button once to set TIMER OFF. The character of HOUR and OFF will flash. Press the "+" or "-" button within 5s to adjust the time of TIMER ON. Each time the "+" or "-" button is pressed, time will increase or decrease by half an hour. When holding the "+" or "-" button for at least 2s, the time will change quickly until the required time is reached. After that, press the "TIMER" button to confirm it. The character of HOUR and OFF won't flash again. Cancel TIMER OFF: Press the "TIMER" button again under TIMER OFF status.
- At OFF status, press this button once to set TIMER ON. Please refer to TIMER OFF for detailed operation.
Cancel TIMER ON: Press the "TIMER" button again under TIMER ON status.

Note:

- Time setting range: 0.5-24 hours.
- Time interval between two operations can't exceed 5s, otherwise the remote controller will exit the setting status automatically.
- The TIMER OFF function is resetted when the CHILD LOCK function is unlocked.

Introduction to buttons on remote controller

9

TURBO button

When pressing this button under cooling or heating mode, the air conditioner will enter into quick cooling or quick heating mode. The "TURBO" icon is displayed on the remote controller. Press this button again to exit turbo function and the "TURBO" icon will disappear on the remote controller.

10

SLEEP button

Press this button under cooling, heating or drying mode to start up sleep function. The "☾" icon will be displayed on the remote controller. Press this button again to cancel the sleep function. The "☾" icon on the remote controller will be displayed.

11

LIGHT button

Press this button to turn off the light on the display of the indoor unit. Press this button again to turn on the light on the display of the indoor unit.

Introduction to functions of combination buttons

Child lock function

Pressing the "+" and "-" buttons simultaneously can turn the child lock function on or off. When the child lock function is started up, the "🔒" icon will be displayed on the remote controller. If any buttons are then pressed on the remote controller, the "🔒" icon will flash three times, while the remote controller won't send any signal.

Switchover function for temperature display

After turning off the unit with the remote controller, press the "-" button and the "MODE" button simultaneously to switch between °C and °F.

Operation guide

1. After putting through the power, press "ON/OFF" button on remote controller to turn on the air conditioner.
2. Press "MODE" button to select your required mode: AUTO, COOL, DRY, FAN, HEAT.
3. Press "+" or "-" button to set your required temperature. (Temperature can't be adjusted under auto mode).
4. Press "FAN" button to set your required fan speed: auto, low, medium and high speed.
5. Press the "SWING" button to select fan blowing angle.

Replacement of batteries in remote controller

1. Press the back side of remote controller marked with "OPEN", as shown in the fig, and then push out the cover of battery box along the arrow direction.
2. Replace two 7# (AAA 1.5V) dry batteries, and make sure the position of "+" polar and "-" polar are correct.
3. Reinstall the cover of battery box.

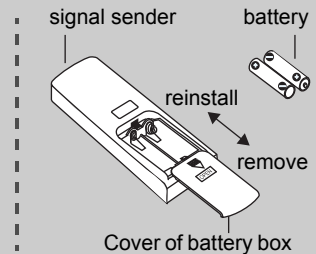

Note:

- During operation, point the remote control signal sender at the receiving window on indoor unit.
- The distance between signal sender and receiving window should be no more than 8m, and there should be no obstacles between them.
- Signal may be interfered easily in the room where there is fluorescent lamp or wireless telephone; remote controller should be close to indoor unit during operation.
- Replace new batteries of the same model when replacement is required.
- When you don't use remote controller for a long time, please take out the batteries.
- If the display on remote controller is fuzzy or there's no display, please replace batteries.

Emergency operation

If remote controller is lost or damaged, please use auxiliary button to turn on or turn off the air conditioner. The operation in details are as below: As shown in the fig. Open panel, press aux. button to turn on or off the air conditioner. When the air conditioner is turned on, it will operate under auto mode.

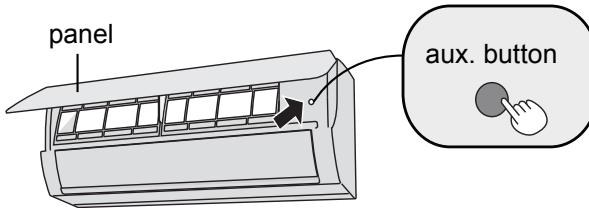

Cleaning and Maintenance

Note:

- Turn off the air conditioner and disconnect the power before cleaning the air conditioner to avoid electric shock.
- Do not wash the air conditioner with water to avoid electric shock.
- Do not use volatile liquid to clean the air conditioner.

Clean surface of indoor unit

When the surface of indoor unit is dirty, it is recommended to use a soft dry cloth or wet cloth to wipe it.

Note:

- Do not remove the panel when cleaning it.

Cleaning and Maintenance

Clean filter

1 Open panel

Pull out the panel to a certain angle as shown in the fig.

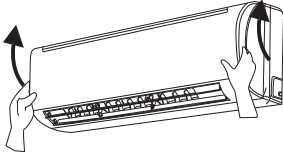

2 Remove filter

Remove the filter as indicated in the fig.

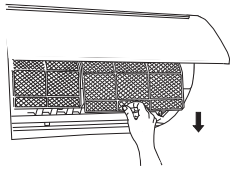

3 Clean filter

- Use dust catcher or water to clean the filter
- When the filter is very dirty, use the water (below 45°C) to clean it, and then put it in a shady and cool place to dry.

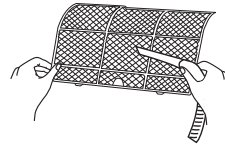

4 Install filter

Install the filter and then close the panel cover tightly.

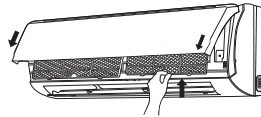

Note:

- The filter should be cleaned every three months. If there is much dust in the operation environment, cleaning frequency can be increased.
- After removing the filter, do not touch fins to avoid injury.
- Do not use fire or hair dryer to dry the filter to avoid deformation or fire hazard.

Cleaning and Maintenance

Checking before active season

1. Check whether air inlets and air outlets are blocked.
2. Check whether earth leakage circuit breaker, plug and socket are in good condition.
3. Check whether filter is clean.
4. Check whether mounting bracket for outdoor unit is damaged or corroded. If yes, please contact dealer.
5. Check whether drainage pipe is damaged.

Checking after active season

1. Disconnect power supply.
2. Clean filter and indoor unit's panel.
3. Check whether mounting bracket for outdoor unit is damaged or corroded. If yes, please contact dealer.

Notice for recovery

1. Many packing materials are recyclable materials. Please dispose of them in appropriate recycling unit.
2. If you want to dispose of the air conditioner, please contact local dealer or consultant service center for the correct disposal method.

Malfunction analysis

General phenomenon analysis

Please check below items before asking for maintenance. If the malfunction still can't be eliminated, please contact local dealer or qualified professionals.

Phenomenon	Check items	Solution
Indoor unit can't receive remote controller's signal or remote controller doesn't seem to work.	<ul style="list-style-type: none"> Whether it's interfered severely (such as static electricity, stable voltage)? 	<ul style="list-style-type: none"> Switch the power off. After about 3min, switch the unit on again.
	<ul style="list-style-type: none"> Whether remote controller is within the signal receiving range? 	<ul style="list-style-type: none"> Signal receiving range is 8m.
	<ul style="list-style-type: none"> Whether there are obstacles? 	<ul style="list-style-type: none"> Remove obstacles.
	<ul style="list-style-type: none"> Whether remote controller is pointing at the receiving window? 	<ul style="list-style-type: none"> Select proper angle and point the remote controller at the receiving window on indoor unit.
	<ul style="list-style-type: none"> Is sensitivity of remote controller low; fuzzy display and no display? 	<ul style="list-style-type: none"> Check the batteries. If the power of batteries is too low, please replace them.
	<ul style="list-style-type: none"> No display when operating remote controller? 	<ul style="list-style-type: none"> Check whether remote controller appears to be damaged. If yes, replace it.
	<ul style="list-style-type: none"> Fluorescent lamp in room? 	<ul style="list-style-type: none"> Take the remote controller close to indoor unit. Turn off the fluorescent lamp and then try it again.
No air emitted from indoor unit	<ul style="list-style-type: none"> Air inlet or air outlet of indoor unit is blocked? 	<ul style="list-style-type: none"> Eliminate obstacles.
	<ul style="list-style-type: none"> Under heating mode, indoor temperature is reached to set temperature? 	<ul style="list-style-type: none"> After reaching to set temperature, indoor unit will stop blowing out air.
	<ul style="list-style-type: none"> Heating mode is turned on just now? 	<ul style="list-style-type: none"> In order to prevent blowing out cold air, indoor unit will be started after delaying for several minutes, which is a normal phenomenon.

Malfunction analysis

Phenomenon	Check items	Solution
Air conditioner can't operate	<ul style="list-style-type: none"> ● Power failure? 	<ul style="list-style-type: none"> ● Wait until power recovery.
	<ul style="list-style-type: none"> ● Earth leakage circuit breaker trips off or fuse is burnt out? 	<ul style="list-style-type: none"> ● Ask professional to replace earth leakage circuit breaker or fuse.
	<ul style="list-style-type: none"> ● Wiring has malfunction? 	<ul style="list-style-type: none"> ● Ask professional to replace it.
	<ul style="list-style-type: none"> ● Unit has restarted immediately after stopping operation? 	<ul style="list-style-type: none"> ● Wait for 3min, and then turn on the unit again.
	<ul style="list-style-type: none"> ● Whether the function setting for remote controller is correct? 	<ul style="list-style-type: none"> ● Reset the function.
Mist is emitted from indoor unit's air outlet	<ul style="list-style-type: none"> ● Indoor temperature and humidity is high? 	<ul style="list-style-type: none"> ● Because indoor air is cooled rapidly. After a while, indoor temperature and humidity will decrease and mist will disappear.
Set temperature can't be adjusted	<ul style="list-style-type: none"> ● Unit is operating under auto or save mode? 	<ul style="list-style-type: none"> ● Temperature can't be adjusted under auto and save modes. Please switch the operation mode if you need to adjust temperature.
	<ul style="list-style-type: none"> ● Your required temperature exceeds the set temperature range? 	<ul style="list-style-type: none"> ● Set temperature range: 16°C~30°C .
Cooling (heating) effect is not good.	<ul style="list-style-type: none"> ● Voltage is too low? 	<ul style="list-style-type: none"> ● Wait until the voltage resumes to normal.
	<ul style="list-style-type: none"> ● Filter is dirty? 	<ul style="list-style-type: none"> ● Clean the filter.
	<ul style="list-style-type: none"> ● Set temperature is in proper range? 	<ul style="list-style-type: none"> ● Adjust temperature to proper range.
	<ul style="list-style-type: none"> ● Door and window are open? 	<ul style="list-style-type: none"> ● Close door and window.

Malfunction analysis

Phenomenon	Check items	Solution
Odours are emitted	<ul style="list-style-type: none">• Whether there's odour source, such as furniture and cigarette, etc.	<ul style="list-style-type: none">• Eliminate the odour source.• Clean the filter.
Air conditioner operates suddenly	<ul style="list-style-type: none">• Whether there's interference, such as thunder, wireless devices, etc.	<ul style="list-style-type: none">• Disconnect power, put back power, and then turn on the unit again.
Outdoor unit has vapor	<ul style="list-style-type: none">• Heating mode is turned on?	<ul style="list-style-type: none">• During defrosting under heating mode, it may generate vapor, which is a normal phenomenon.
"Water flowing" noise	<ul style="list-style-type: none">• Air conditioner is turned on or turned off just now?	<ul style="list-style-type: none">• The noise is the sound of refrigerant flowing inside the unit, which is a normal phenomenon.
Cracking noise	<ul style="list-style-type: none">• Air conditioner is turned on or turned off just now?	<ul style="list-style-type: none">• This is the sound of friction caused by expansion and/or contraction of panel or other parts due to the change of temperature.

Warning

- When the following phenomenon occurs, please turn off the air conditioner and disconnect power immediately, and then contact the dealer or qualified professionals for service.
 - Power cord is overheating or damaged.
 - There's abnormal sound during operation.
 - Earth leakage circuit breaker trips off frequently.
 - Air conditioner gives off burning smell.
 - Indoor unit is leaking.
- Do not repair or refit the air conditioner by yourself.
- If the air conditioner operates under abnormal conditions, it may cause malfunction, electric shock or fire hazard.

Wiring

- Do not turn ON the safety breaker until all work is completed.
 - 1) For both outdoor and indoor units, strip the insulation from the wire (40mm).
 - 2) Connect the connection wires between the indoor and outdoor units **so that the terminal numbers match**. Tighten the terminal screws securely. We recommend a flathead screw driver be used to tighten the screws.
 - 3) For connecting outdoor unit to indoor unit use standardized supply cable H05RN.

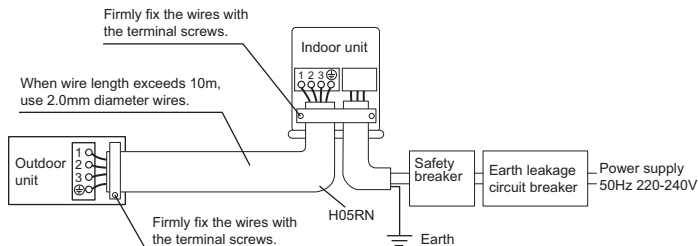

Wiring

Wiring Diagram

Indoor Unit

AP	Printed Circuit Board
TEM.Sensor.....	Temperature Sensor
RT.....	Thermistor
W.....	Wire
DISP.....	Display
CN.....	Connector
AC-L.....	Alternating current-live line
K.....	Relay
PG.....	Pulse Generator
PGF.....	Pulse Generator Feedback
M.....	Motor
L-OUT.....	Line-out
COM-OUT.....	Communication-Out
N.....	Naught
XT.....	Terminal Block
PE.....	Protective earth
BN.....	Brown
BU.....	Blue
BK.....	Black
YEGN.....	YellowGreen
RD.....	Red
YE.....	Yellow
VT.....	Violet
L.....	Live line
Jump Cap.....	The cap of the jumper
(U.D).....	Up, Down
GN.....	Green

Outdoor Unit

AP	Printed Circuit Board
TEM.Sensor.....	Temperature Sensor
RT.....	Thermistor
OVC-COMP.....	Compressor Overload Protector
EKV.....	Electronic expansion valve coil
CN.....	Connector
AC-L.....	Alternating current-live line
AC-N.....	Alternating current-neutral line
YV.....	Way valve
OFAN.....	Outdoor Fan
DC.....	Direct Current
WH.....	White
COM-OUT.....	Communication-Out
N.....	Naught
XT.....	Terminal Block
PE.....	Protective earth
BN.....	Brown
BU.....	Blue
BK.....	Black
YEGN.....	YellowGreen
RD.....	Red
YE.....	Yellow
VT.....	Violet
L.....	Live line
4V.....	Four-way valve
COM.....	Communication
COMP.....	Compressor
SAT.....	Overload protection service
OG.....	Orange
FA.....	Electric expansion interface
INDC.....	Port of reactor

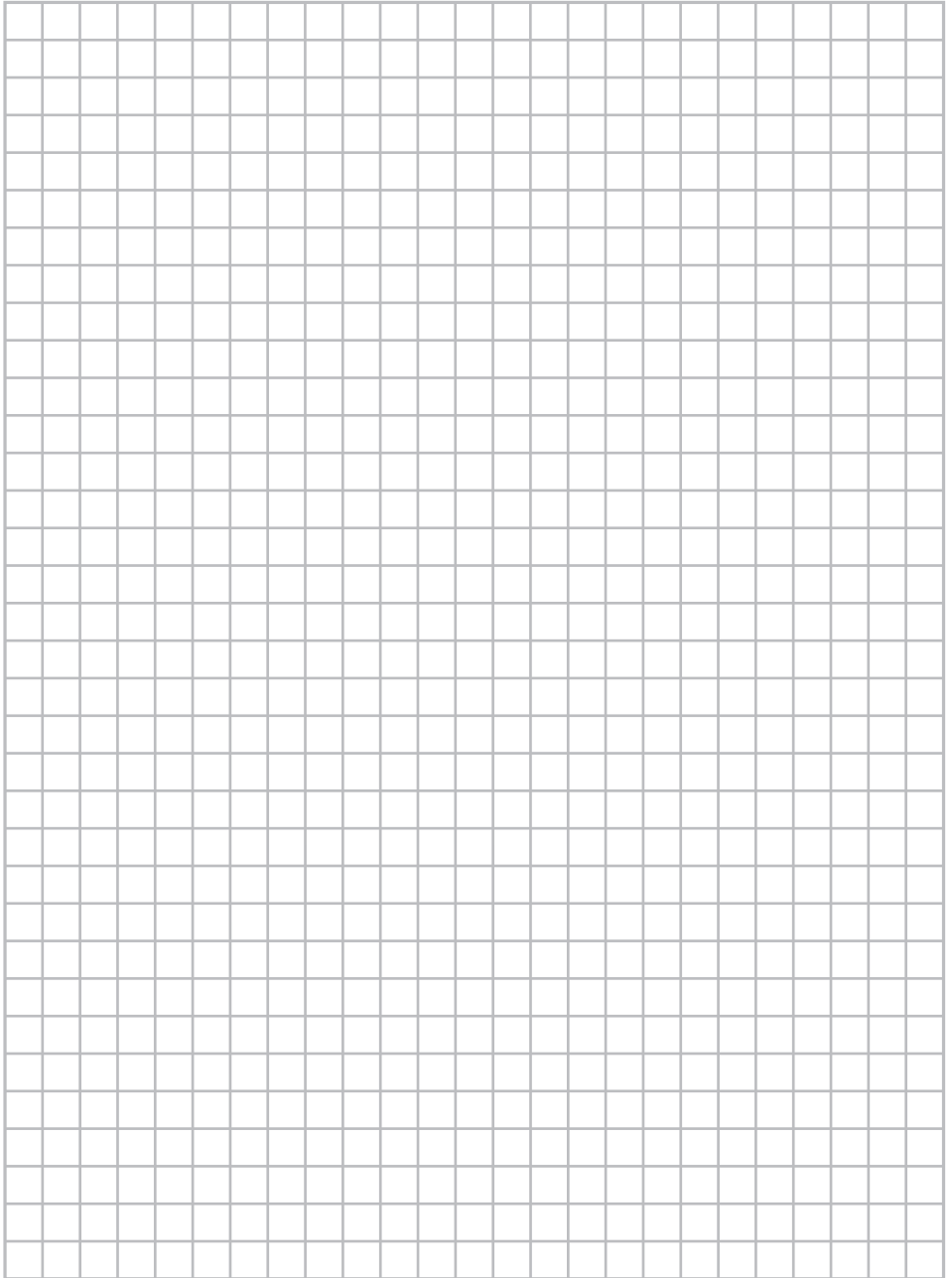

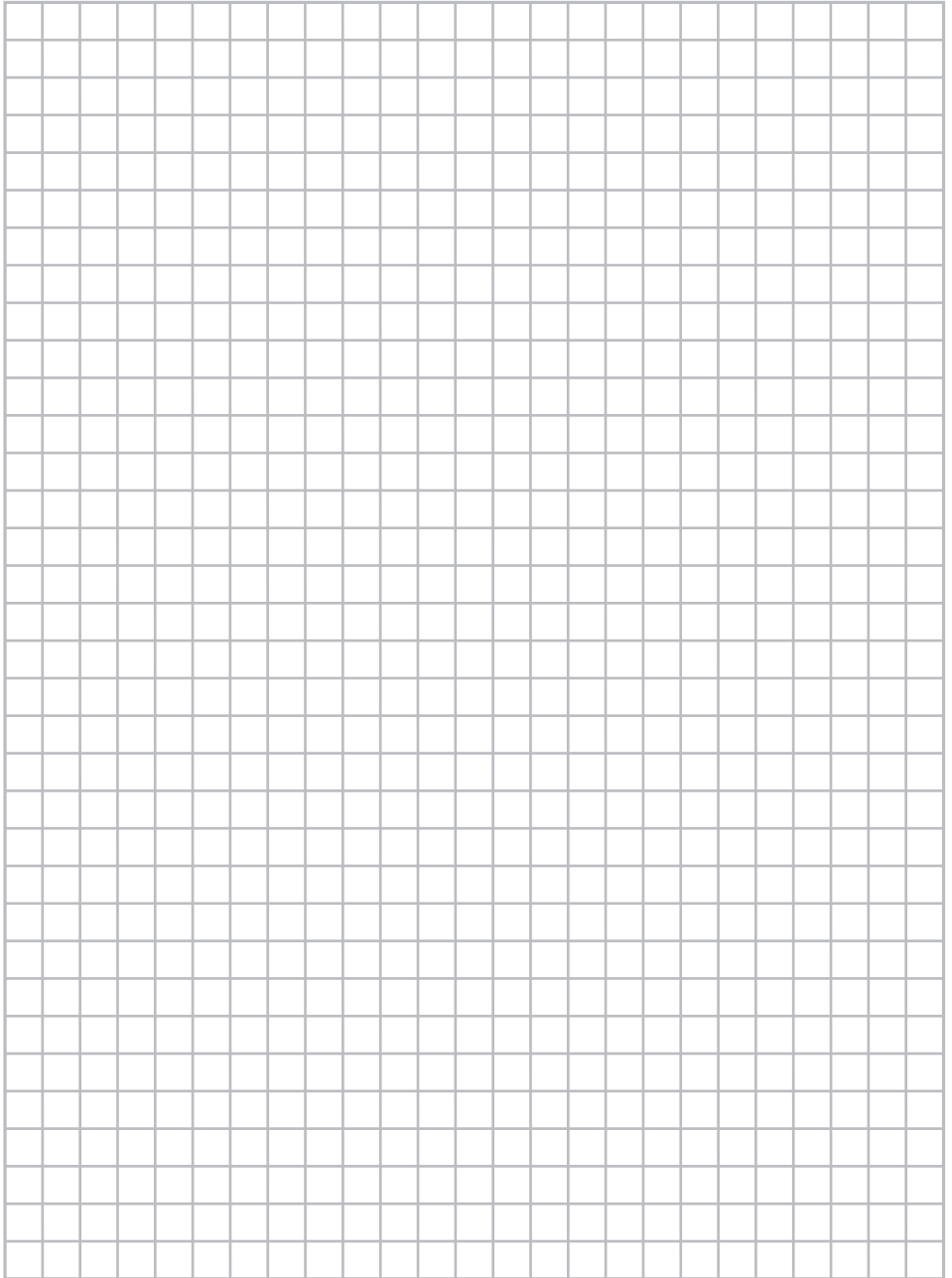

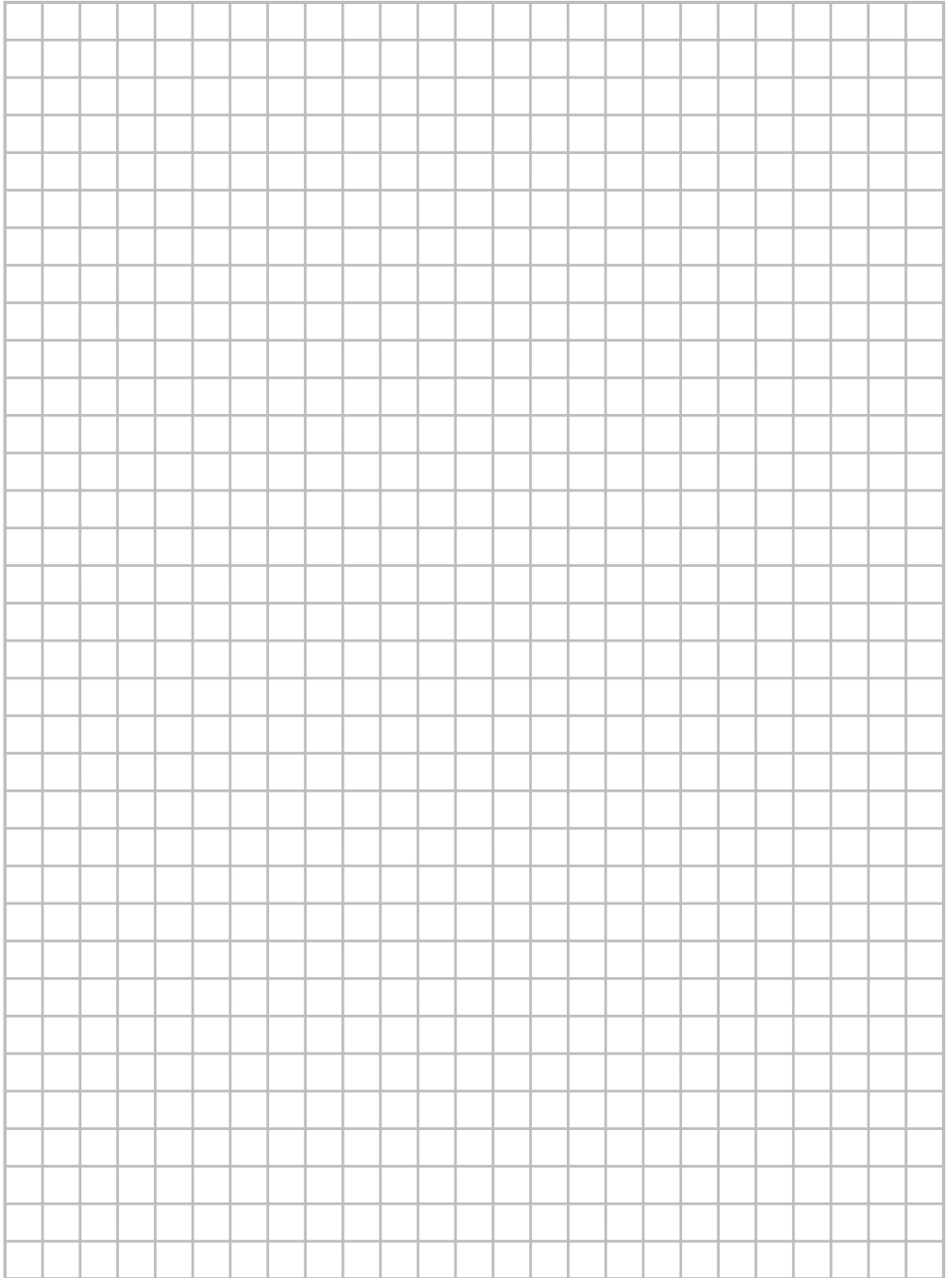

DAIKIN EUROPE N.V.

Zandvoordestraat 300, B-8400 Oostende, Belgium

Copyright 2013 Daikin



66129915142